



ColoriSens: An open-source and low-cost portable color sensor board for microfluidic integration with wireless communication and fluorescence detection



Yushen Zhang, Tsun-Ming Tseng*, Ulf Schlichtmann

Chair of Electronic Design Automation, Technical University of Munich, 80333 Munich, Germany

ARTICLE INFO

Article history:

Received 15 March 2022
Received in revised form 25 April 2022
Accepted 26 April 2022

Keywords:

Colorimetric sensor
Portable microfluidic
Lab-on-a-chip
Fluorescence detection
Microfluidic analysis

ABSTRACT

Microfluidic colorimetric biosensors have shown promising potential for detecting metal cations, anions, organic dyes, drugs, pesticides. As for today, most colorimetric sensors are read by a smartphone or professional optical imaging system, and there is still a lack of an affordable and reliable colorimetric detector for the microfluidic chip. Integrating those reading and detection capabilities into a microfluidic system is essential for point-of-care (POC) detection and can enable more complex microfluidic operations, such as lab-on-a-chip experiments or programmable microfluidics. We developed an open-source colorimetric detection sensor board that can be integrated into the existing microfluidic system. This sensor board has a built-in UV source that enables fluorescence detection. With built-in USB and Wi-Fi connectivity and a set of simple APIs, microfluidic systems can communicate directly with this sensor board, even wirelessly. The sensor was designed for low-cost. With a total build cost of less than 12 EUR per unit, it is ideal for low-cost systems and DIY microfluidic users. Along with the sensor board, we also designed a companion microfluidic chip carrier cartridge which can be modified depending on the chip's dimension. To demonstrate the sensor, we also developed a cross-platform open-source client application to demonstrate the communication APIs and the functionality of the sensor board.

© 2022 The Author(s). Published by Elsevier Ltd. This is an open access article under the CC BY-NC-ND license (<http://creativecommons.org/licenses/by-nc-nd/4.0/>).

Specifications table

Hardware name	ColoriSens
Subject area	<ul style="list-style-type: none"> • Chemistry and biochemistry • Medical (e.g., pharmaceutical science) • Biological sciences (e.g., microbiology and biochemistry)

(continued on next page)

* Corresponding author.

E-mail address: tsun-ming.tseng@tum.de (T.-M. Tseng).

(continued)

Hardware name	ColoriSens
Hardware type	<ul style="list-style-type: none"> • Environmental, planetary and agricultural sciences • Educational tools and open source alternatives to existing infrastructure • Measuring physical properties and in-lab sensors • Biological sample handling and preparation • Field measurements and sensors
Closest commercial analog	No commercial analog is available.
Open source license	Creative Commons Attribution-ShareAlike 4.0 (CC BY-SA 4.0)
Cost of hardware	12 EUR
Source file repository	https://doi.org/10.17605/OSF.IO/TCZJR

Hardware in context

Microfluidic devices couple classical fluid dynamics at the macro scale with the dominant surface tension forces at the micro scale to precisely manipulate small volumes of fluid. This is highly advantageous when implementing sensing strategies, as reagent consumption can be reduced, and individual operations can be performed in parallel, which in turn reduces both analysis time and costs. As a result, these devices are finding use in a number of research and industrial areas such as biomedical applications [1,2], environmental monitoring [3], and food processing [4]. Microfluidic colorimetric sensors, as one type of microfluidic sensor, present a visible assay result in the form of intensity changes of colors. The changes can be caused by UV-visible absorption [5], fluorescence [6], bioluminescence [7], or chemiluminescence [8]. Although colorimetric analysis can be performed simply by visual comparison, this only provides qualitative information, and quantitative measurements are highly dependent on bulky and costly equipment, which inevitably increases analysis time. Professional colorimetric and fluorescence detection devices are inaccessible, bulky, and expensive.

In recent years, smartphones have been equipped with many remarkable features, making them a promising digital platform for colorimetric detection. Many smartphone-based detection methods were proposed [9–11]. This rapid, simple, portable, ubiquitously available, and cost-effective technology enables minimally trained users to perform colorimetric analyses in the field. However, this technology is still only intended to analyze the assay result. Integration into a complex microfluidic system is not available.

With the advances of microfluidic technology, complex, multi-layer microfluidics become the trend. Programmable microfluidics were proposed [12–14], taking advantage of an actively controllable microfluidic device, where the routing of fluids from different locations to different locations becomes possible. Even for low-cost 3D-printed microfluidic devices, a control mechanism exists [15]. One essential task of programmable microfluidics is to detect the progress of an experiment for control decision making. Thus, integrating sensors into the microfluidic system can be crucial to enable programmable microfluidics, or lab-on-a-chip.

This work introduces a low-cost open-source colorimetric detection hardware – ColoriSens – that is tailored for microfluidic applications and can be integrated into existing microfluidic systems.

Hardware description

The ColoriSens is a board-shaped sensor of $10 \times 60 \times 100$ mm that consists of a two-layer printed circuit board (PCB). It provides Wi-Fi and USB connectivity for both wireless and wired communication. The communication happens via API calls. On top of the board, a 3D-printed microfluidic chip cartridge holds the microfluidic chip at the designated area. ColoriSens integrates two light sources: white and ultra-violet light that helps to illuminate the microfluidic chip and induce fluorescence on fluorescent probes. Upon API calls, ColoriSens reads the intensity of red, green, and blue of the designated reading area and returns the readings, while the white and UV light source's brightness can be individually adjusted and the readings can be scaled. All settings, such as Wi-Fi credential, LED brightness, or reading scaling, will be saved on the hardware that allows it, for instance, to automatically connect to the last connected Wi-Fi access point for each use.

The communication method (wired or wireless) can be easily switched by long-pressing the button on the hardware until the LED indicator blinks. Wireless communication provides Wi-Fi direct communication and WLAN (Wireless Local Area Network) communication modes. That means, depending on the usage and circumstances, the user can connect the device (a microfluidic system, controller, computer, etc.) directly to the board using Wi-Fi without an intermediate Wi-Fi router, or users can also let the hardware join their WLAN like a usual Wi-Fi capable device with a given Wi-Fi router. We provide a set of convenient and straightforward APIs for wired and wireless communication methods to operate the hardware. ColoriSens also provides additional GPIO pins that create the possibility to connect external modules that can interface with the device, allowing users to add hardware modules that extend the device's functionality. Fig. 1 depicts the pinout.

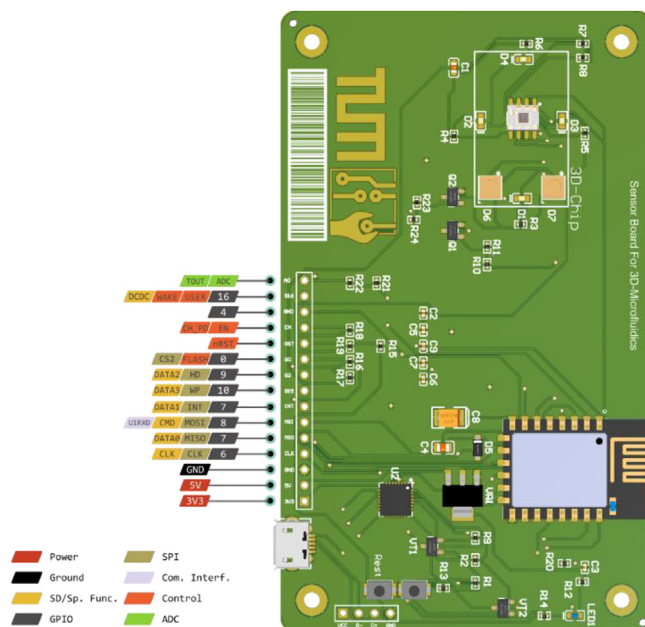

Fig. 1. Pinout of ColoriSens.

The entire hardware can be seen as being comprised of five major parts: (1) color sensor, (2) light sources, (3) SoC (System on a Chip) microprocessor, (4) USB-to-UART bridge, and (5) 3D-printed microfluidic chip cartridge. We describe each part's functionality in more detail.

Color sensor

ColoriSens has an AMS-OSRAM TCS3200 as the color sensor to detect the intensity of different colors. The TCS3200 color sensor detects red, green, and blue colors and outputs a square wave signal (50% duty cycle) with frequency directly proportional to light intensity (irradiance). The output signal will be sent to the SoC microprocessor and further processed.

Light sources

Colorisens integrates two light sources: white light and ultra-violet light that help to illuminate the microfluidic chip. The white light source consists of four white LEDs, and the ultra-violet light source consists of two ultra-violet C and ultra-violet A (270–280 nm and 390–400 nm) combo LEDs. Both white and UV light sources can be controlled and adjusted individually.

SoC microprocessor

ColoriSens uses an Ai-Thinker ESP-12F module as the brain of the entire hardware. The ESP-12F module has an ESP8266 – a high-performance wireless SoC – integrating the industry-leading Tensilica L106 ultra-low-power 32-bit microcontroller unit (MCU). The integrated Wi-Fi supports the standard IEEE802.11b/g/n Wi-Fi protocol, a complete TCP/IP protocol stack. The USB connection is ensured via Silicon Labs CP2102. The main task of the ESP-12F is to control and operate the TCS3200 and the LEDs and process and respond to the API calls through Wi-Fi and USB connections.

USB-to-UART bridge

Colorisens has a Silicon Labs CP2102 USB bridge providing a virtual COM (serial) port interface via USB. Since the ESP-12F only provides serial communication, the USB bridge is required to talk to ESP-12F through the USB connection. Hence, the user can use this USB virtual COM port to send commands to and receive responses from the hardware.

Microfluidic chip cartridge

Full and half-size microfluidic chip cartridge designs are provided along with the board. The cartridge ensures that the chip is stably located at the designated zone and that the color sensor is close to the sensing area of the chip.

ColoriSens' main advantage over pre-existing colorimeters or smartphone-based color detection solutions [9,16,17] is its lower cost, lower power usage, portability, small size, integrability into a microfluidic system, and ease of use. Its two communication interfaces and low power usage make it very suitable for integration into the existing microfluidic system, such as the low-cost portable microfluidic system PAMICON [15]. There is no existing solution for an integrable colorimetric reading solution for microfluidic systems, which is highly important for programmable microfluidics and lab-on-a-chip. The main contributions of ColoriSens include:

- ColoriSens provides two ways of communication and utilizes simple APIs to operate.
- ColoriSens can easily be integrated into the existing microfluidic system enabling programmable microfluidics and lab-on-a-chip [13].
- The lightweight and small size allow it to be used in multiple scenarios such as POC.
- The low-cost idea helps the spread of microfluidics in general and could be suitable in fields of education.
- It is also ideal to use ColoriSens in other low-cost microfluidic scenarios, such as in combination with 3D-printed microfluidics and low-cost microfluidic system.

Design files

All design files, including the hardware design, firmware, 3D models of the cartridge, and demo software, are made available as open-source and provided along with this article (Table 1). The design files consist of all the information needed to produce, assemble, and run this hardware.

Table 1
List of design files made available with this article.

Design file name	File type	Open source license	Location of the file
ColoriSens board	PCB and schematic designs, Gerber, BOM, and pick-and-place file	CC BY-SA 4.0	https://doi.org/10.17605/OSF.IO/TCZJR
Microfluidic chip cartridges	CAD designs	CC BY-SA 4.0	https://doi.org/10.17605/OSF.IO/TCZJR
ColoriSens firmware	Binary and source code files	CC BY-SA 4.0	https://doi.org/10.17605/OSF.IO/TCZJR
Demo client software	Executable and source code files	CC BY-SA 4.0	https://doi.org/10.17605/OSF.IO/TCZJR
Demo microfluidic chip	CAD design	CC BY-SA 4.0	https://doi.org/10.17605/OSF.IO/TCZJR

Electronics

The ColoriSens board files are provided in Altium Designer schematic and PCB layout as source files. Besides commercial software, these files can also be read and modified with free software such as EasyEDA or KiCAD using free migration tools such as Altium2kicad. We also provide the Gerber, BOM, and pick-and-place files for PCB fabrication and SMT assembly. Fig. 2 shows the PCB layout. The schematic is split into eight labeled functional circuit groups: Power, white LEDs, UV LEDs, RGB Sensor, Buttons, USB TTL, SoC, and Pins. Each group is described in detail:

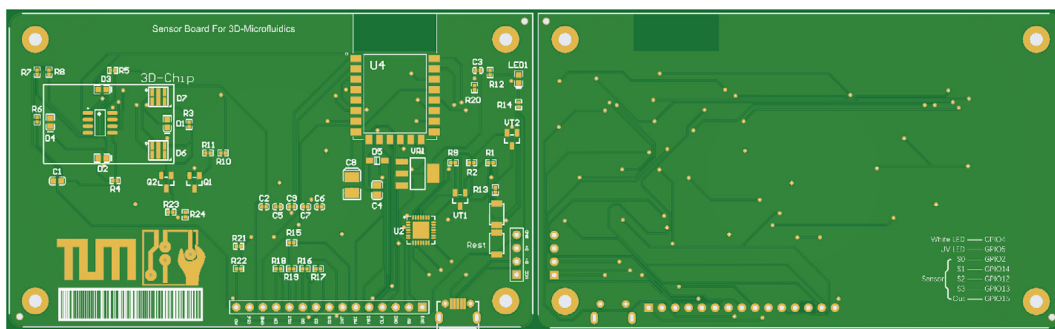

Fig. 2. ColoriSens PCB layouts (top layer left; bottom layer right).

Power

ColoriSens acquires its power from the Micro-USB port, which provides a 5 V power. Internally it has two power circuits with different voltages (Fig. 3). The two voltages are 3.3 V and 5 V. The internal 5 V comes directly from the USB connection. At the same time, 3.3 V is converted from 5 V through a voltage regulator AMS1117-3.3.

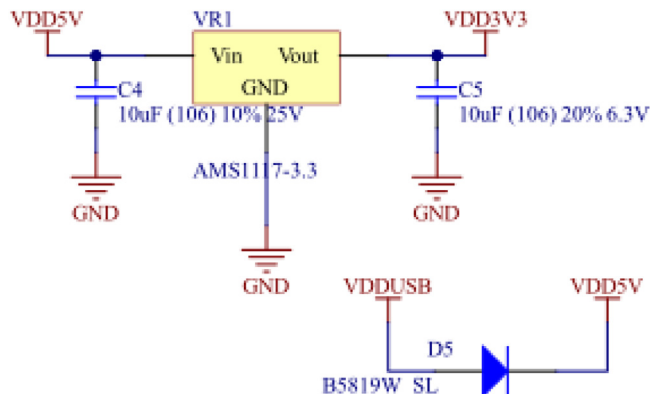

Fig. 3. Power circuit schematic.

White LEDs

The white light source consists of four white LEDs powered by 3.3 V with 220 Ω ballast resistors. These LEDs' brightness should be controllable via the SoC. Hence the control signal is amplified by an SS8050 transistor (Fig. 4).

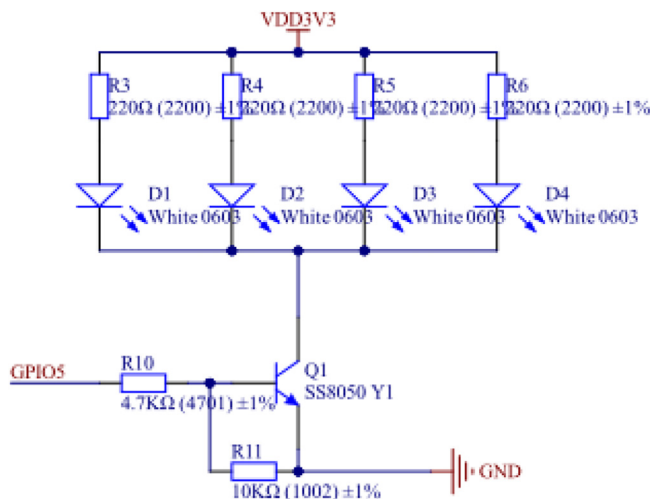

Fig. 4. White LEDs circuit schematic.

UV LEDs

With two ultra-violet C and ultra-violet A combo LEDs, the ultra-violet light source is analogous to the white LEDs but powered directly by 5 V and 3.3 V and controlled by a different signal input (Fig. 5).

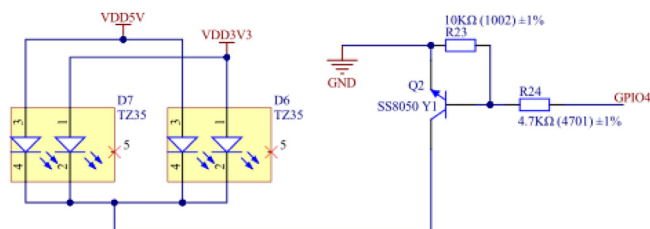

Fig. 5. UV LEDs circuit schematic.

RGB sensor:

The TCS3200 is powered by 3.3 V, and a decoupling capacitor is used to stabilize the power. Each pin is connected directly to the SoC, except \overline{OE} is connected to the ground (Fig. 6).

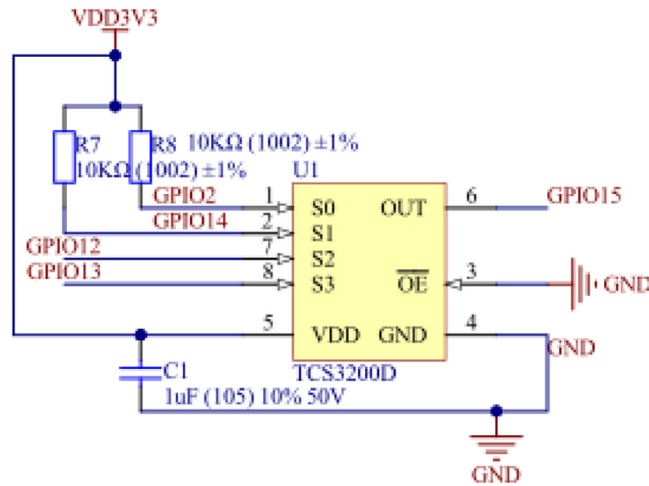

Fig. 6. RGB sensor circuit schematic.

Buttons

Two buttons are placed on the ColoriSens board. One button is used to reset the SoC and restart the firmware, and another button is used to switch the communication mode. Pull-up/pull-down resistors are connected to these buttons (Fig. 7). It is worth mentioning that the resistor R14 should only be populated when one wants to invoke the sleep function of the ESP-12F SoC.

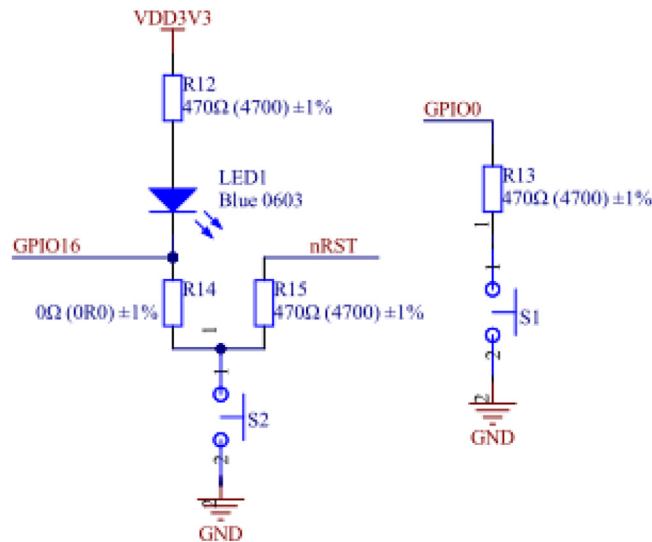

Fig. 7. Buttons circuit schematic.

USB TTL

The CP2102 USB bridge is connected between the SoC's serial communication pins and the USB. ColoriSens provides a Micro-USB port along with a four-pin header/hole that allows the user to directly solder a USB cable to the board (Fig. 8).

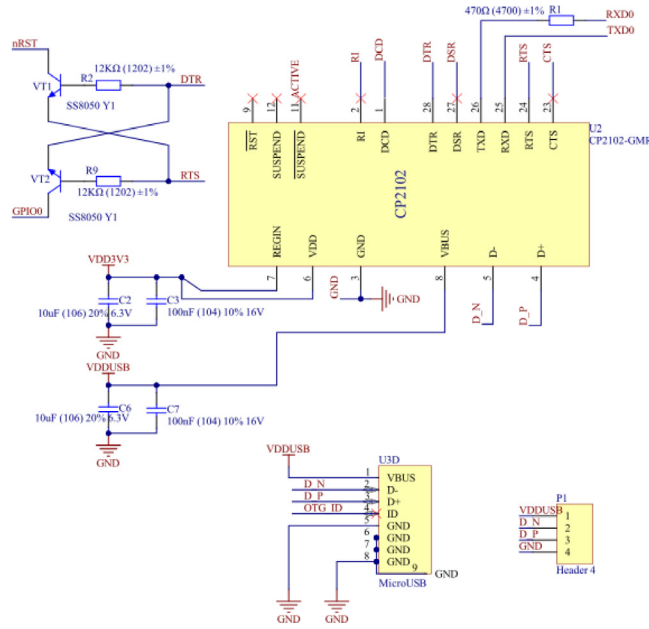

Fig. 8. USB bridge circuit schematic.

SoC

The SoC ESP-12F links to all functional groups described above (Fig. 9). It has a built-in 32Mbit SPI Flash which stores the firmware. Additional GPIO connections are linked to the pinholes on the board and provide further hardware extensibility.

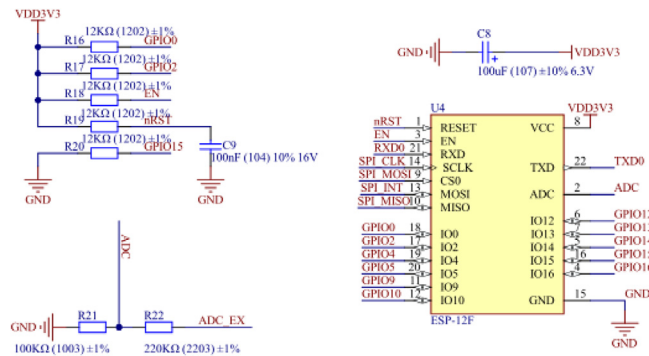
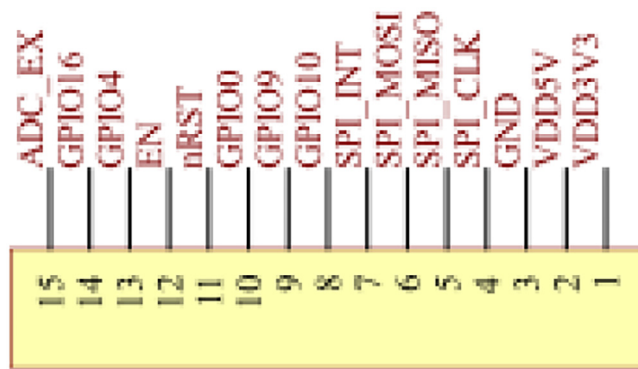

Fig. 9. SoC circuit schematic.

Pins

The expansion pinholes allow the connection of additional hardware or sensors (Fig. 10). Fig. 1 shows the pinout of the board.



J1 Header 15

Fig. 10. Pin headers schematic.

3D-printing

We modeled all designs with Shapr3D CAD software. The microfluidic chip cartridge design files contain a full-size and a half-size cartridge design (in STEP and STL format). The full-size cartridge has a size of $8 \times 60 \times 100$ mm, which is designed to cover the entire board (Fig. 11-a). A half-size cartridge has a size of $8 \times 60 \times 40$ mm and only covers the sensing area (Fig. 11-b). The cartridge should be placed on the board to hold the chip in the slot. Depending on the size, design, and application of the chip, users are able to modify the cartridge designs freely. The designs can be fabricated with a 3D printer or CNC machining. A lid to cover the chip slot area is also provided and shall be modified depending on the need. For example, if lab-on-a-chip experiments should be performed, the lid should provide hollowed space for chip in-/outlets. The lid should be fabricated in white and can be used for white balancing and reading calibration depending on the configured light source brightness.

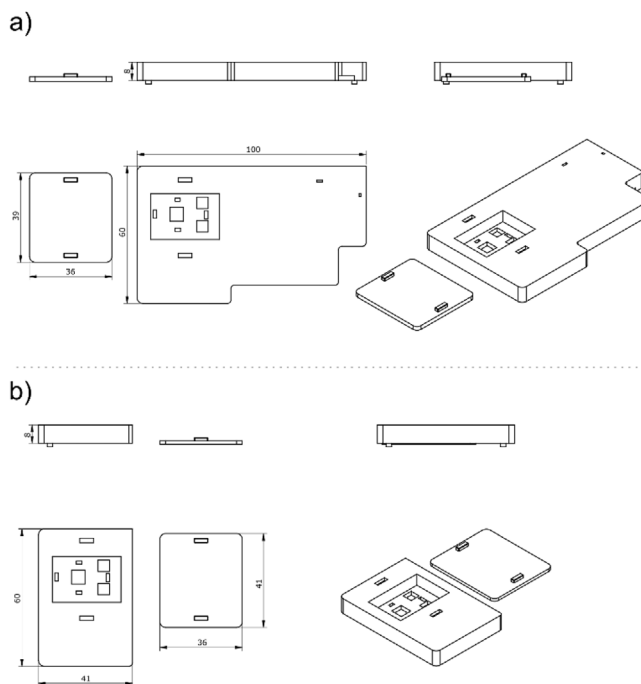

Fig. 11. Construction of cartridges.

The demo microfluidic chip design (provided in STEP and STL format) shows the chip we use in the hardware verification process. It replicates a simple mixing application. We recommend using an SLA/DLP/LCD 3D printer to fabricate this chip. In terms of running microfluidic applications, a bio-compatible resin, such as the MiiCraft BV-007, is recommended to print the chip.

Software and firmware

The firmware is written in Arduino/C++. We make both the source code and the compiled binary file available. The binary file can be directly flashed to the hardware with any ESP-flashing tool. The detailed APIs and commands this firmware provides and how to use the provided functionalities are described in the following sections. The cross-platform demo client (Fig. 12) is written in Java. It runs on Windows, macOS, all Linux distributions, Solaris, FreeBSD, and OpenBSD and is independent of the CPU architecture. We make both the source code and the compiled executable jar file available. The demo client implements both the serial communication and the Wi-Fi web API and demonstrates how to operate the hardware using them. This demo client can be used as a reference for integrating ColoriSens into the existing microfluidic control software.

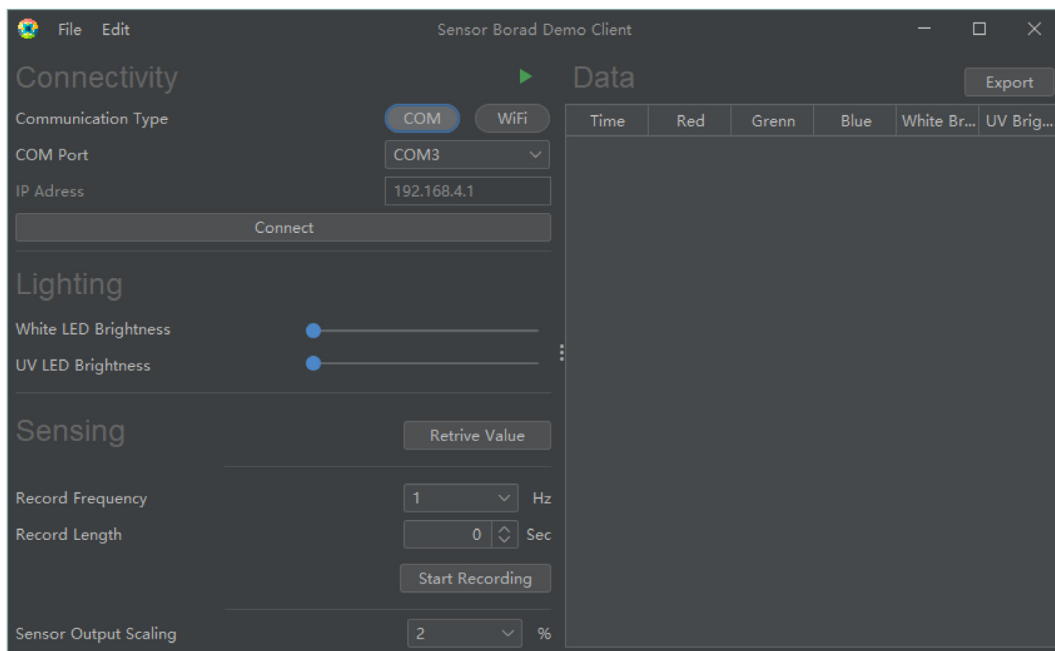

Fig. 12. Demo client application.

Bill of materials

Build instructions

ColoriSens PCB

The bare PCB can be acquired by uploading the Gerber file or design file to an online PCB manufacturing company. Many of these PCB manufacturing companies also provide SMT assembly services. This service requires the upload of the BOM (bill of materials) and pick-and-place file. The assembly service charges for the populated components, service fee, and tooling setup fees. However, using the assembly service along with the PCB fabrication can save a significant amount of time and cost. For ColoriSens, five ready-to-use units (except the firmware, which needs to be flashed afterward), including the fabrication of the five PCBs and their SMT assembly, cost in total about 57 EUR (shipping fee and customs clearance are not included).

Manual assembly from the bare PCB would take, depending on the soldering method, approximately five hours per unit. All components must be soldered by hand. It is recommended to use solder paste and stencil, which can be ordered along with the PCB at many PCB manufacturing companies. Then assemble them using a reflow-oven. To assemble the hardware, first, sort all components into labeled component bins referring to the bill of materials (Table 2). Second, place the side of PCB where the silkscreen designators are visible to the top, and use the stencil, if available, to past the solder paste. Last, place

Table 2

Bill of materials. Total material cost for one unit is 9.62 EUR. All costs except the SMT assembly, shipping, and any additional handling fees. We paid about 57 EUR for five units, including the SMT assembly (shipping fee and customs clearance are not included).

Designator	Component	Quantity per unit	Cost per unit - EUR	Total cost - EUR	Source of materials	Material type
C1	0603 1uF (105) 10% 50 V	1	0.0080	0.0080	https://lcsc.com/	Electronics
C2, C5, C6	0402 10uF (106) 20% 6.3 V	3	0.0205	0.0615	https://lcsc.com/	Electronics
C3, C7, C9	0402 100nF (104) 10% 16 V	3	0.0045	0.0135	https://lcsc.com/	Electronics
C4	0805 10uF (106) 10% 25 V	1	0.1119	0.1119	https://lcsc.com/	Electronics
C8	3528 100uF (107) 10% 6.3 V	1	0.6332	0.6332	https://lcsc.com/	Electronics
D1, D2, D3, D4	0603 LED White	4	0.0157	0.0628	https://lcsc.com/	Electronics
D5	SOD-123 B5819W SL	1	0.0940	0.0940	https://lcsc.com/	Electronics
D6, D7	TZ35UVA + UVC02-016	2	0.6149	1.2298	https://lcsc.com/	Electronics
LED1	0603 LED Blue	1	0.0867	0.0867	https://lcsc.com/	Electronics
Q1, Q2, VT1, VT2	SOT-23 SS8050 Y1	4	0.0218	0.0872	https://lcsc.com/	Electronics
R1, R12, R13, R15	0402 470 Ω (4700) 1%	4	0.0015	0.0060	https://lcsc.com/	Electronics
R10, R24	0402 4.7 KΩ (4701) 1%	2	0.0018	0.0036	https://lcsc.com/	Electronics
R2, R9, R16, R17, R18, R19, R20	0402 12 KΩ (1202) 1%	7	0.0014	0.0098	https://lcsc.com/	Electronics
R21	0402 100 KΩ (1003) 1%	1	0.0047	0.0047	https://lcsc.com/	Electronics
R22	0402 220 KΩ (2203) 1%	1	0.0040	0.0040	https://lcsc.com/	Electronics
R3, R4, R5, R6	0402 220 Ω (2200) 1%	4	0.0015	0.0060	https://lcsc.com/	Electronics
R7, R8, R11, R23	0402 10 KΩ (1002) 1%	4	0.0015	0.0060	https://lcsc.com/	Electronics
S1, S2	SHOU HAN TS342A2P-WZ	2	0.0519	0.1038	https://lcsc.com/	Electronics
U1	AMS TCS3200D-TR	1	2.8975	2.8975	https://lcsc.com/	Electronics
U2	CP2102-GMR	1	1.8797	1.8797	https://lcsc.com/	Electronics
U3	MicroUSB	1	0.0678	0.0678	https://lcsc.com/	Electronics
U4	Ai-Thinker ESP-12F (ESP8266MOD)	1	1.2187	1.2187	https://lcsc.com/	Electronics
VR1	SOT-223 AMS1117-3.3	1	0.1087	0.1087	https://lcsc.com/	Electronics
ColoriSens PCB	1.6 mm FR4-Standard Tg 130-140C PCB	1	0.3360	0.3360	https://jlcpcb.com/	PCB
Chip cartridge	3D-printing resin	1	0.5800	0.5800	Amazon	3D-printing supplies

each component according to the designator's name and the polarization according to the silkscreen sign, then use the reflow-oven or hot air gun to solder them onto the PCB. Fig. 13 shows the PCB with all components soldered.

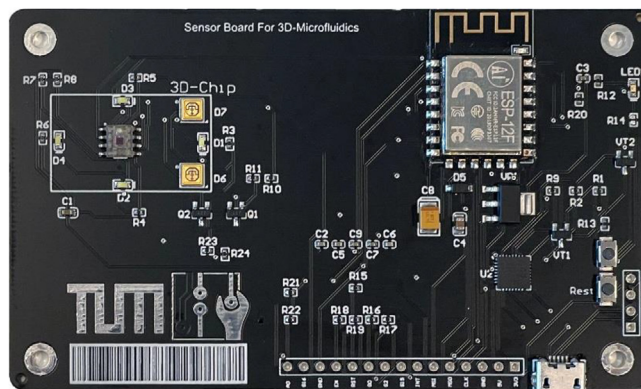

Fig. 13. PCB with all components soldered.

List of equipment needed to build the PCB board (if not assembled):

- Soldering iron or reflow-oven/hot air gun
- Solder/solder paste
- Tweezers
- Flux pen
- Flux off
- Alcohol PCB cleaner

Firmware

After the PCB assembly has been done, the firmware bin file can be uploaded using a Micro-USB cable and any ESP-flashing software, such as the official Espressif Esptool [18]. Use the following command to accomplish the flashing process when using the Esptool:

```
esptool.py --port<serial-port-of-ColoriSens>write_flash -fm dio 0x00000 firmware.bin
```

Cartridge

We recommend using an SLA/DLP/LCD resin printer to 3D-print the cartridge since it delivers the best quality. We also recommend leveling up and turning the design about 20–30° in the printer’s slicing software and adding appropriate support. After the design has been printed, wash and cut off all supports and do a post-exposure for about 5–10 min. Fig. 14 shows a 3D-printed half-size cartridge.

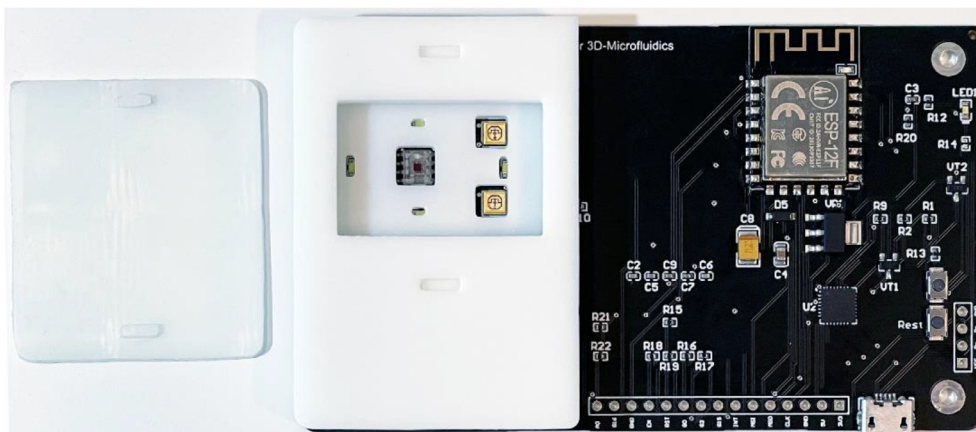

Fig. 14. 3D-printed half-size cartridge mounted on PCB.

Operation instructions

Safety instruction: ColoriSens integrates a UV source. Exposure may cause eye damage. Do not operate without coverings. Do not look into the UV source. Wear appropriate UV eye protection.

ColoriSens can be used in different scenarios. It can be integrated into the existing microfluidic system and controller. To ease the use of ColoriSens, it provides a set of commands (API) for serial communication (wired) and a set of web APIs for Wi-Fi communication. For integration usage, the microfluidic system’s software should implement the communication APIs to operate with ColoriSens. ColoriSens comes initially set as serial communication mode out of the box (default setting in the firmware). By long pressing the upper (unlabeled) button on ColoriSens for three seconds, until the upper right blue LED indicator blinks, the communication mode will switch between serial and Wi-Fi. The upper right blue LED also indicates that ColoriSens is powered on. The lower button is the reset button. Pressing the reset button restarts ColoriSens. We describe the operation and API of each communication method in detail.

Serial communication

In serial communication mode, users need to connect ColoriSens and the client (computer, microfluidic system, etc.) with a USB cable. The client will recognize it as a USB serial port. In order to communicate with ColoriSens, this serial port’s baud rate should be set to 115200. ColoriSens communicates through a command-and-response fashion, which means that to a command sent to it, ColoriSens will respond with a reply. Before integrating the API, we recommend manually sending the command “HELP” to check out the API. Table 3 shows all serial APIs ColoriSens provides.

Table 3

Serial communication APIs. The scaling defines the output precision. Light brightness is defined as: 0 – darkest, 1023 – brightest.

Feature description	Command	Variable range	Response example
Turn on/off the white LEDs	SET WHITE <i>state</i>	<i>state</i> : ON, OFF	OK
Turn on/off the UV LEDs	SET UV <i>state</i>	<i>state</i> : ON, OFF	OK
Change the brightness of the white LEDs	SET WHITE LEVEL <i>level</i>	<i>level</i> : [0 – 1023]	OK
Change the brightness of the UV LEDs	SET UV LEVEL <i>level</i>	<i>level</i> : [0 – 1023]	OK
Change the sensor output scaling	SET SCAL <i>scaling</i>	<i>scaling</i> : 2, 20, 100	OK
Get sensor data	GET RGB		[20,67,102]
Factory reset and clear all settings	FACTORYRESET		

Wi-Fi communication

ColoriSens can also be used wirelessly. An external power supply, such as a USB power bank, is needed in this configuration. Wi-Fi communication mode provides both Wi-Fi direct connection (AP mode) and WLAN connection (STA mode) simultaneously. That means users can always connect to ColoriSens using Wi-Fi direct, even if it is connected to a WLAN. ColoriSens exposes itself with the Wi-Fi name (SSID) "SensorBoard," and to connect to it, the required Wi-Fi password is "magicword." ColoriSens' IP address for Wi-Fi direct connection is "192.168.4.1," which should be used to establish the communication. To let ColoriSens join a WLAN, connecting to ColoriSens using Wi-Fi direct beforehand is required. ColoriSens provides an API to configure the WLAN connection, but it also provides a convenient website UI to configure. By opening "http://192.168.4.1/connectWifi" in the browser with a smartphone or computer connected to ColoriSens using Wi-Fi direct, ColoriSens can be configured to join a WLAN by selecting the name of nearby WLAN from a list (Fig. 15). The IP address of ColoriSens within the WLAN can be viewed through the WLAN router's backend or by calling the API (see below). The API call happens by using HTTP GET-Method with "http://[IP-address]/[API]" to fetch the response. Most of the APIs return a JSON as the response body. Table 4 shows all web APIs provided. Opening the IP address of ColoriSens in a browser also shows the API overview.

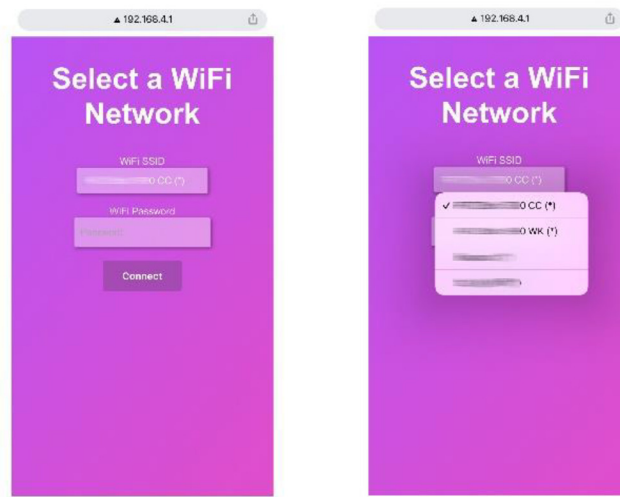

Fig. 15. WLAN configuration.

Table 4
Wi-Fi communication web APIs.

Feature description	API	Variable(s) range	Response example
Connect the board to WLAN/Wifi	<code>/setWifi?ssid=<u>MyWifiName</u>&pswd=<u>WifiPassword</u></code>	<u>MyWifiName</u> : Wi-Fi SSID <u>WifiPassword</u> : Wi-Fi password	<i>A website</i>
Turn on/off the white LEDs	<code>/setWhite?state=<u>state</u></code>	<u>state</u> : on, off	<code>{"success": "true"}</code>
Turn on/off the UV LEDs	<code>/setUV?state=<u>state</u></code>	<u>state</u> : on, off	<code>{"success": "true"}</code>
Change the brightness of the white LEDs	<code>/setWhite?level=<u>level</u></code>	<u>level</u> : [0 - 1023]	<code>{"success": "true"}</code>
Change the brightness of the UV LEDs	<code>/setUV?level=<u>level</u></code>	<u>level</u> : [0 - 1023]	<code>{"success": "true"}</code>
Change the sensor output scaling	<code>/setScal?scaling=<u>scaling</u></code>	<u>scaling</u> : 2, 20, 100	<code>{"success": "true"}</code>
Get sensor data	<code>/getRGB</code>		<code>{"value": {"R": 45, "G": 65, "B": 102}, "success": "true"}</code>
Get the sensor board's IP addresses	<code>/getIP</code>		<code>{"direct": "192.168.4.1", "lan": "192.168.1.101", "success": "true"}</code>
Factory reset and clear all settings	<code>/factoryreset</code>		<code>"success": "true"</code>

ColoriSens saves the settings, such as connection mode, light brightness, or Wi-Fi credential. All settings can be cleared and restored to default by calling the factory reset.

The reading of ColoriSens represents the detected light intensity of red, green, and blue. The reading can be scaled by 2%, 20%, and 100%. The scaling defines the reading precision. The lower the reading, the higher is the intensity. If the user wants to turn the readings into a 24-bit RGB value, the user can do white balance calibration for the desired setting beforehand and

use simple linear regression to map the values. To do a white balance calibration, users should turn on the white light to desired brightness and put a piece of black paper to cover the chip slot. Record the reading [r1, g1, b1]. Then do it again with a closed white lid or a piece of white paper and record the reading [r2, g2, b2]. The 24-bit RGB value [R, G, B] can be calculated from ColoriSens' reading [r, g, b] as follows:

$$R(r) = 255 \cdot \frac{r - r1}{r2 - r1}, G(g) = 255 \cdot \frac{g - g1}{g2 - g1}, B(b) = 255 \cdot \frac{b - b1}{b2 - b1}$$

Validation and characterization

In this section, we demonstrate the function of ColoriSens. We have implemented the demo client to demonstrate the integrability of the hardware. The client software can operate ColoriSens and retrieve readings using API calls. Any microfluidic control software can implement these APIs to integrate ColoriSens.

Further, we 3D-printed a microfluidic chip with a chamber as a colorimetric biosensor. We filled the channel and the chamber with different food dyes to simulate an assay result of a colorimetric biosensor (Fig. 16, sample 1–3). We also tested the fluorescence reading by using fluorescence dye (Fig. 16, sample 4) with the integrated UV light source of ColoriSens. We carried out all measurements with the demo client application. The following diagram shows the readings.

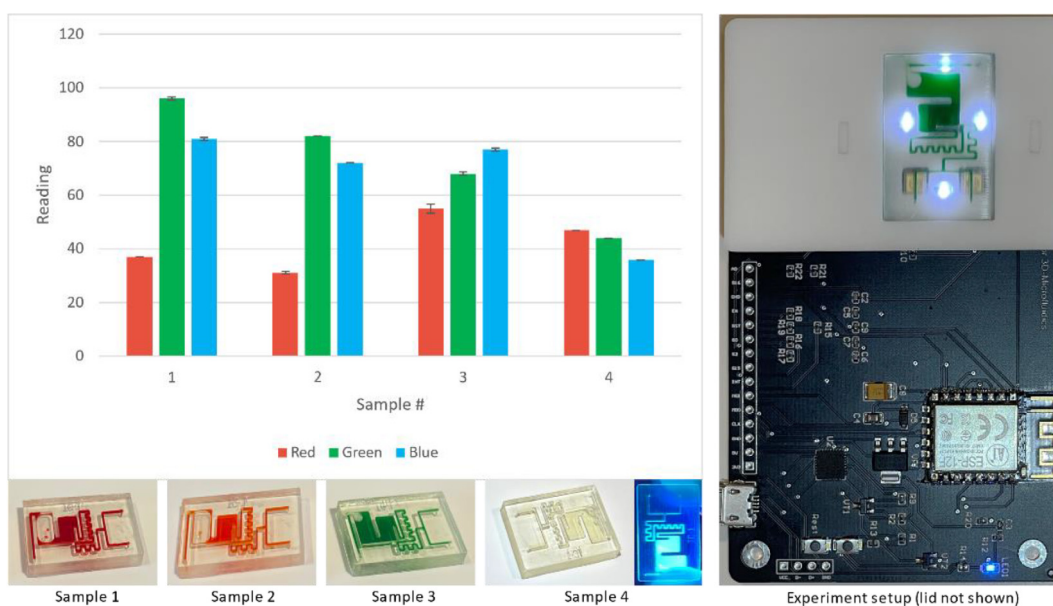

Fig. 16. ColoriSens evaluation. Red, green, and blue bars represent the measured result of each color channel. The lower the reading, the more intensive the color. The sample measures 1–3 are performed with white light at a brightness level of 460, while sample measure 4 is performed with UV light at a brightness level of 881. The scaling was set to 20%. Error bars represent the standard deviation of three replicate measurements of each sample. The chip was put into a half-size cartridge with the lid closed during the measurements. (For interpretation of the references to color in this figure legend, the reader is referred to the web version of this article.)

We also tested the API response speed of ColoriSens. Both serial and Wi-Fi communication can reply up to 5 Hz (5 responses per second). That indicates that ColoriSens is capable of performing real-time lab-on-a-chip experiments. A control decision can be made instantly based on the fast response.

The power consumption was tested with a digital multimeter (JT-UM25C, Joy-IT/Simac Electronics GmbH). ColoriSens consumes 1.08 W of power at both lights at maximum brightness. In a moderate scenario, where only white light is set to brightness level 400, ColoriSens consumes 0.60 W of power.

Conclusion

In this paper, we have described the hardware design of ColoriSens – a color detector for microfluidics. We have given instructions on the location of its open-source design files, the construction of two chip cartridges, and demonstrative client software showing how to implement the APIs of the hardware and how to communicate with ColoriSens. ColoriSens can be used for many different scenarios and applications, such as monitoring, POC, and programmable microfluidics. ColoriSens' low cost, small size, low power operation, and simple construction help spread low-cost, portable microfluidics.

CRediT authorship contribution statement

Yushen Zhang: Conceptualization, Investigation, Visualization, Software, Writing – original draft. **Tsun-Ming Tseng:** Supervision, Validation, Writing – review & editing. **Ulf Schlichtmann:** Funding acquisition, Writing – review & editing.

Declaration of Competing Interest

The authors declare that they have no known competing financial interests or personal relationships that could have appeared to influence the work reported in this paper.

Acknowledgements

This work is supported by the Deutsche Forschungsgemeinschaft (DFG, German Research Foundation) Project Number 456006534.

References

- [1] D. Eicher, C.A. Merten, Microfluidic devices for diagnostic applications, *Expert Rev. Mol. Diagnost.* 11 (5) (2011) 505–519.
- [2] J. Yakovleva, R. Davidsson, A. Lobanova, M. Bengtsson, S.A. Eremin, T. Laurell, J. Emnéus, Microfluidic enzyme immunoassay using silicon microchip with immobilized antibodies and chemiluminescence detection, *Anal. Chem.* 74 (13) (2002) 2994–3004.
- [3] Y. Hui, Y. Liu, W.C. Tang, D. Song, M. Madou, S. Xia, T. Wu, Determination of Mercury(II) on A Centrifugal Microfluidic Device Using Ionic Liquid Dispersive Liquid–Liquid Microextraction, *Micromachines* 10(8), pp. 523–523, 2019.
- [4] J. Liu, I. Jasim, Z. Shen, L. Zhao, M. Dweik, S. Zhang, M. Almasri, A microfluidic based biosensor for rapid detection of Salmonella in food products, *PLoS One* 14 (5), 2019.
- [5] S.-K. Lee, M. Sheridan, A. Mills, Novel UV-activated colorimetric oxygen indicator, *Chem. Mater.* 17 (10) (2005) 2744–2751.
- [6] J. Hu, C. Li, Y. Cui, S. Liu, Highly selective colorimetric and fluorometric probes for fluoride ions based on nitrobenzofurazan-containing polymers, *Macromol. Rapid Commun.* 32 (7) (2011) 610–615.
- [7] R. Haggart, G.H.G. Thorpe, S.B. Moseley, L.J. Kricka, T. Whitehead, An enhanced chemiluminescent enzyme immunoassay for serum carcinoembryonic antigen based on a modification of a commercial kit, *J. Biolumin. Chemilumin.* 1 (1) (1986) 29–34.
- [8] D. Melucci, B. Roda, A. Zattoni, S. Casolari, P. Reschiglian, A. Roda, Field-flow fractionation of cells with chemiluminescence detection, *J. Chromatogr. A* 1056 (1) (2004) 229–236.
- [9] Y. Chen, Q. Fu, D. Li, J. Xie, D. Ke, Q. Song, Y. Tang, H. Wang, A smartphone colorimetric reader integrated with an ambient light sensor and a 3D printed attachment for on-site detection of zearalenone, *Anal. Bioanal. Chem.* 409 (28) (2017) 6567–6574.
- [10] A.Y. Mutlu, V. Kilic, G.K. Özdemir, A. Bayram, N. Horzum, M.E. Solmaz, Smartphone-based colorimetric detection via machine learning, *Analyst* 142 (13) (2017) 2434–2441.
- [11] T. Cao, Y. Zhao, S.M. Weiss, A smartphone compatible colorimetric biosensing system based on porous silicon, *Proceed. SPIE 10077* (2017) 1007713.
- [12] J.P. Urbanski, W. Thies, C. Rhodes, S. Amarasinghe, T. Thorsen, Digital microfluidics using soft lithography, *Lab Chip* 6 (1) (2006) 96–104.
- [13] B. Thies, V. Ananthanarayanan, Towards a high-level programming language for standardizing and automating biology protocols, in *International Workshop on Bio-Design Automation*, San Francisco, CA, 2009.
- [14] J.W. Parks, M.A. Olson, J. Kim, J. Kim, D. Ozcelik, H. Cai, R. Carrion, J.L. Patterson, R.A. Mathies, A.R. Hawkins, H. Schmidt, Integration of programmable microfluidics and on-chip fluorescence detection for biosensing applications, *Biomicrofluidics* 8 (5) pp. 054111–054111, 2014.
- [15] Y. Zhang, T.-M. Tseng, U. Schlichtmann, Portable all-in-one automated microfluidic system (PAMICON) with 3D-printed chip using novel fluid control mechanism, *Sci. Rep.* 11 (2021) 19189.
- [16] S.C. Kim, U.M. Jalal, S.B. Im, S. Ko, J.S. Shim, A smartphone-based optical platform for colorimetric analysis of microfluidic device, *Sensors Actuators B-Chem.* 239 (2017) 52–59.
- [17] Y. Wang, Y. Wang, X. Liu, P. Chen, N.T. Tran, J. Zhang, W.S. Chia, S. Boujday, S. Boujday, B. Liedberg, Smartphone spectrometer for colorimetric biosensing, *Analyst* 141 (11) (2016) 3233–3238.
- [18] Espressif SoC serial bootloader utility. <https://github.com/espressif/esptool>, (accessed 02.03.2022).



Yushen Zhang received the B.Sc. and M.Sc. degrees in Computer Science (Informatics) from Technical University of Munich (TUM), Germany, in 2017 and 2020, respectively. He is currently a research associate and doctoral candidate in the Chair of Electronic Design Automation at TUM. He works on several research topics including computer-aided design, microfluidic biochips, and 3D-printed microfluidics.

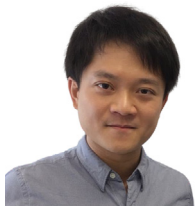

Tsun-Ming Tseng received the bachelor degree in electronics engineering from National Chiao Tung University (NCTU), Hsinchu, Taiwan, in 2010, the M.Sc. and the Dr.-Ing. degrees from Technical University of Munich (TUM), Munich, Germany, in 2013 and 2017, respectively. He leads a research group in the Chair of Electronic Design Automation, TUM. His research interests focus on design automation for emerging technologies, such as microfluidic biochips and optical networks-on-chips.



Ulf Schlichtmann received the Dipl.Ing. and Dr.-Ing. degrees in electrical engineering and information technology from Technical University of Munich (TUM), Munich, Germany, in 1990 and 1995, respectively. He was with Siemens AG, Munich, and Infineon Technologies AG, Munich, from 1994 to 2003, where he held various technical and management positions in design automation, design libraries, IP reuse, and product development. He has been a Professor and the Head of the Chair of Electronic Design Automation, TUM, since 2003, where he also served as Dean of the Department of Electrical and Computer Engineering, from 2008 to 2011, and as Associate Dean of Studies of International Studies since 2013. Since 2016, he is an elected member of TUM's Academic Senate and Board of Trustees. He is a member of the German National Academy of Science and Engineering and also serves on a number of advisory boards. Ulf's current research interests include computer-aided design of electronic circuits and systems, with an emphasis on designing reliable and robust systems. In recent years, he has increasingly worked on emerging technologies, such as microfluidic biochips and optical interconnect.