

Numerical Study on the Effect of Gravity on Modal Analysis of Thin-Walled Structures

Theo Kiesel¹⁾, Patrick Langer²⁾, Steffen Marburg²⁾

¹⁾ Technische Hochschule Ostwestfalen-Lippe University of Applied Sciences and Arts, Campusallee 12, 32657 Lemgo, Germany. theo.kiesel@th-owl.de

²⁾ Gerhard Zeidler Chair of Vibroacoustics of Vehicles and Machines Technische Universität München, Boltzmannstraße 15, 85748 Garching bei München, Germany

Summary

Computational modal analysis is usually carried out without consideration of gravity forces. This is well motivated for many structures. However, the vibrational properties of thin-walled plane or shallow shell structures are very sensitive with respect to small modifications of the shell geometry and with respect to in-plane stress and reinforcement. One reason for these in-plane stresses and geometric modifications consists in gravity. This becomes an important issue when using test data obtained under the presence of gravity to update a simulation model where the influence of gravity is neglected. This study investigates the influence of gravity on the modal parameters of a thin rectangular plate and of a thin-walled cubic box. For that, different simulation models are used. While all of them utilize the finite element method, linear and non-linear approaches are compared. The latter take into account geometrical nonlinearities due to large deformations and the influence of gravity induced stress.

© 2018 The Author(s). Published by S. Hirzel Verlag · EAA. This is an open access article under the terms of the Creative Commons Attribution (CC BY 4.0) license (<https://creativecommons.org/licenses/by/4.0/>).

PACS no. 43.40.At, 43.40.Dx, 43.40.Ey, 43.40.Ga, 43.40.Le, 43.40.Yq

1. Introduction

Experimental modal analysis (EMA) is a powerful tool to compare and update simulation models that describe the dynamic behavior of a structure [1]. EMA can be performed on assemblies, as well as on a single component of that assembly. However, when comparing the experimental data with theoretical results, the boundary conditions of the examined structure must be the same in the experiment and in the simulation model. In most cases the structure is measured in so called free-free conditions, because these conditions are supposed to be easily realizable in practice [2]. “Free-free” means that “the test object is not attached to the ground at any of its coordinates and is, in effect, freely suspended in space” [3].

Regarding modal testing, “free-free” also means, that there are no other loads acting on the structure during the test, except the measured excitation forces. Usually it is impossible to perfectly match these conditions, because the test object must be suspended in some way and gravity is normally present during the test¹. It can be shown that if the object is suspended in soft springs in such a way that

the highest rigid body mode is five to ten times smaller than the lowest structural mode, the influence of the added stiffness of the springs on the structural modes can be neglected [3].

It is, however, not only the added stiffness of the suspension that might lead to a deviation between experimental data with assumed (but not fully achieved) free-free conditions and a simulation model perfectly matching these boundary conditions. The force equilibrium between the weight of the test object and the suspension causes stress, and geometrical deformation, that might change the modal parameters.

Especially thin beams [5], shells [6] and plates [7, 8, 9] are known to behave very sensitive to in-plane stress and changes in the curvature, causing the lateral stiffness to change significantly. The interdependence between in-plane stress and lateral stiffness in plate-like structures plays an important role when calculating the ultimate strength and the buckling or collapsing modes in civil engineering [10], ships [11] and aircraft or submarine fuselages [12, 13, 14].

In many cases, the effect of gravity on the vibrational behavior of structures, however, is ignored. Exceptions can be found amongst objects designed to be deployed into

Received 13 October 2017,
accepted 9 April 2019.

¹ A noteworthy exception is given in [4], reporting of EMA being performed on a space shuttle in orbit. The results are compared to measure-

ments on the ground. Regarding the influence of gravity on the natural frequencies similar conclusions are drawn like in the present article.

space, which require intensive testing and computations before being launched. For obvious reasons, most of the tests need to be done on the ground, where gravity is naturally present. References [15, 16, 5] describe the influence of gravity on beam-like structures, while reference [17] deals with a cantilever plate.

The goal of the current paper is to draw attention to the fact that the presence of gravity might have an important influence on the modal parameters of thin-walled structures. As will be shown, the influence of gravity on thin plates might cause in-plane stress as well as large static deformation, which leads to strong nonlinear geometrical effects. These effects need to be accounted for in the theoretical model in order to produce correct results. As a consequence the orientation of a test object should be considered carefully in the case of EMA, and it might become necessary to consider the presence of gravity in the simulation model. When doing so, one should be aware that gravity might introduce a strong geometric nonlinearity which is best addressed by a nonlinear simulation approach. These findings are actually not new, but are tended to be ignored in practice. This paper is intended to increase awareness and to show the significant effect that gravity can have on the modal parameters of thin walled structures.

The goal of the current paper is not to discuss the mathematical foundations to consider in-plane stress in a modal analysis nor to investigate to what extent changes of the modal parameters are caused by stretching the mid-plane surface or by changes of the curvature. Mathematical foundations for in-plane stress can be found in [18, 19].

This paper is organized such that the effect of gravity is demonstrated for a thin plate under different support conditions which is followed by investigation of the effect for a cubic box. The research is purely numerical using the commercial FEM-code Abaqus as a simulation tool.

2. Approach and Methods

Throughout the manuscript, the authors will refer to three different computational approaches, as summarized in Table I.

Approach 1 completely neglects gravity, which results in a standard modal analysis. Approaches 2 and 3 consider the influence of gravity by performing a two-stage simulation. In both approaches, step one calculates the stress and strain distribution due to the presence of gravity, while step two consist of a modal analysis. While both approaches assume linear elastic material behavior, they very much differ in the way they treat geometric nonlinearity in step one and in the way they consider gravity induced stress when performing the modal analysis in step two:

- Approach 2 uses a linear calculation to derive the deformation due to gravity in step one. In step two, the modal analysis is performed using the deformed geometry of step one, but without considering gravity induced stress.

- Approach 3 calculates the deformation and stress due to gravity in a nonlinear computation, taking into account geometric nonlinearities. The modal parameters are derived in a pre-stressed modal analysis, taking into account the gravity-induced deformation and stress, as will be explained in what follows.

The choice of the three different approaches is motivated by typical options of how to deal with the presence of gravity during modal testing. The seemingly easiest way is to simply neglect gravity, which is represented by Approach 1. Approaches 2 and 3 reflect the typical situation for industrial engineers: Commercial FE-Software is usually sold on a modular basis, dividing linear and nonlinear approaches into different software modules. Without a license for a nonlinear solution, a user is unable to perform a pre-stressed modal analysis, thereby forced to neglect the influence of gravity-induced stress on the modal parameters. Gravity-induced deformation, however, can still be considered by performing the modal analysis using the deformed geometry calculated in a previous (linear) simulation. The two approaches lead to significantly different results, as will be explained in Chapter 3.

2.1. Approach 1

When ignoring gravity, the eigenvalues λ and the mode shapes φ are computed by solving the characteristic polynomial equation

$$[\lambda^2 \mathbf{M} + \mathbf{K}] \varphi = \mathbf{0}, \quad (1)$$

wherein \mathbf{M} is the mass matrix and \mathbf{K} is the stiffness matrix derived in the undeformed configuration, meaning without the presence of gravity.

2.2. Approach 2

Approach 2 calculates in step one the strain and stress distribution via a static, linear analysis by solving the equation of the force equilibrium between the external loads and the restoring forces,

$$\mathbf{K} \mathbf{u} = \mathbf{F} \quad (2)$$

\mathbf{F} contains the known external loads, meaning in the current case the gravity force in the form of nodal forces, while \mathbf{u} are the unknown nodal displacements. In a linear analysis, stiffness matrix \mathbf{K} is derived in undeformed configuration and is not updated when the structure deforms due to external loads. Since the lateral stiffness of thin plates is known to increase significantly due to changes in the curvature, the stiffness derived in a linear analysis will always be too low if the plate is subjected to a lateral load. As shall be seen in the following section of the paper, the resulting error in deformation due to gravity can become very large, depending on the orientation of the plate.

At the end of step one, the deformed geometry of the structure is saved and imported in a new simulation to perform a modal analysis (step two). This means, that the stiffness matrix \mathbf{K} in Equation (1) is derived from the deformed geometry due to gravity, but the gravity-induced

Table I. Survey of the procedure.

| | Approach 1 | Approach 2 | Approach 3 |
|--|--------------------------------------|--|--|
| gravity linearity | neglected linear | included linear | included nonlinear |
| Step 1: evaluation of stress and strain due to gravity | – | based on linear theory of small de- formations | based on nonlinear theory of large deformations |
| Step 2: modal analysis | using undeformed (plain) geometry | using deformed geometry from 1, but neglecting gravity induced stress | using deformed geometry from 1, also considering stress distribution from step 1 |

stress is ignored in the modal analysis. Since linear elastic material behavior is assumed, \mathbf{K} is symmetric and solution of Equation (1) is straightforward.

2.3. Approach 3

In contrast to Approach 2, Approach 3 calculates in step one the strain and stress distribution via a static, nonlinear analysis based on theory of large deformations.

ABAQUS solves the equations of the force equilibrium by an incremental-iterative procedure with the Newton-Raphson method, as described program-specifically in [20] and in general terms, amongst others, in [21, 22]. Stiffness matrix \mathbf{K} is replaced by a so-called tangential stiffness matrix, or Jacobi matrix, \mathbf{K}_T ,

$$\mathbf{K}_T = \mathbf{K} + \mathbf{K}_\sigma + \mathbf{K}_v, \quad (3)$$

in which the linear-elastic stiffness matrix \mathbf{K} is modified by several additions, like in the current case the stress dependent *geometric stiffness matrix* \mathbf{K}_σ (sometimes also called *load stiffness matrix*) and a matrix \mathbf{K}_v which contains contributions due to large deformations. Except for \mathbf{K} , all parts of \mathbf{K}_T are recalculated in every increment of the procedure, thereby taking into account the increase in stiffness due to changes in the curvature and due to gravity induced stress.

In step two, a so-called pre-stressed modal analysis is performed, using the modified stiffness matrix from step one. This means that the influence on the modal parameters of both, gravity induced deformation as well as changes in the stiffness due to gravity induced stress, are considered. A vivid example of the procedure is given in [23], also including experimental studies.

Since the geometric stiffness matrix typically is unsymmetrical, solving Equation (1) now requires more effort. One possibility is to transform the equation of motion from the configuration space into a state-space representation and using a complex eigensolver. ABAQUS applies a common alternative by using a subspace projection method and the QZ-algorithm in order to derive the natural frequencies and mode shapes as described, amongst others, in [24].

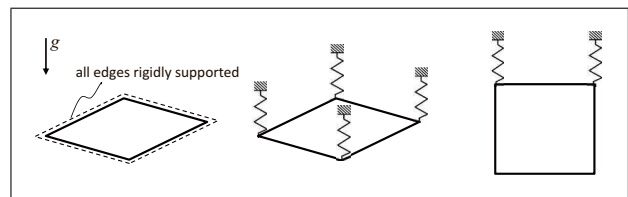

Figure 1. Three different configurations of the square plate: simply supported at all edges (left), horizontally softly suspended (center), and vertically softly suspended (right).

3. Investigation of square plates

3.1. Survey

The first group of test examples uses a square plate under different support conditions. These test examples encompass a plate which is simply supported at all edges, a plate which is horizontally softly suspended to approach the free-free condition and a plate which is vertically softly suspended, also to approach free-free conditions. These test cases are summarized in Figure 1. The considered plate is quadrangular with an edge length of 1 m and a thickness of 1 mm. The material is supposed to be steel with a Young's modulus E of 2.1×10^{11} N/m², a density ρ of 7850 kg/m³ and a Poisson ratio μ of 0.3.

3.2. Simply supported plate

In the first test example, all edges of the plate are rigidly supported, meaning that they cannot undergo translational displacements, but are free to rotate. The natural frequencies f_{mn} of such a plate can be calculated by using the following formula [7]

$$f_{mn} = \frac{\omega_{mn}}{2\pi} = \frac{\pi}{2} \left[\left(\frac{m}{a} \right)^2 + \left(\frac{n}{b} \right)^2 \right] \cdot \sqrt{\frac{B}{\rho h}}, \quad (4)$$

wherein m and n are the numbers of half waves in the x and y direction, a and b stand for the length of each side of the plate, h indicates the thickness and ρ stands for the volumetric mass density. The bending stiffness B is expressed as

$$B = \frac{Eh^3}{12(1 - \mu^2)}. \quad (5)$$

Table II. Simply supported plate - the influence of gravity on the natural frequencies.

| Mode | without gravity | | | including gravity | |
|------|-----------------|----------|------------|-------------------|----------------|
| | Analytical | FEM | Difference | FEM, linear | FEM, nonlinear |
| 1 | 4.92 Hz | 4.91 Hz | -0.04% | 18.9 Hz | 12.3 Hz |
| 2 | 12.29 Hz | 12.29 Hz | -0.03% | 31.0 Hz | 21.4 Hz |
| 3 | 12.29 Hz | 12.29 Hz | -0.03% | 31.0 Hz | 21.4 Hz |
| 4 | 19.67 Hz | 19.66 Hz | -0.04% | 37.2 Hz | 30.1 Hz |
| 5 | 24.59 Hz | 24.58 Hz | -0.02% | 42.3 Hz | 30.2 Hz |
| 6 | 24.59 Hz | 24.58 Hz | -0.02% | 49.0 Hz | 39.5 Hz |
| 7 | 31.96 Hz | 31.95 Hz | -0.04% | 49.1 Hz | 39.5 Hz |
| 8 | 31.96 Hz | 31.95 Hz | -0.04% | 59.8 Hz | 39.7 Hz |
| 9 | 41.80 Hz | 41.79 Hz | -0.01% | 61.6 Hz | 51.5 Hz |
| 10 | 41.80 Hz | 41.79 Hz | -0.01% | 75.2 Hz | 51.8 Hz |

For modeling the plate, elements of the type shell S8R have been used. This type of shell element is based on *Mindlin* plate theory and has been originally designed to account for the shear deformation behavior of thick plates. As shall be seen in the following example, the element is also suitable to model thinner plates. It should be noted, however, that the use of S8R elements require the use of a structured mesh, since irregular meshes converge very poorly because of severe transverse shear locking [20].

Providing a mesh grid with an edge length of 25 mm the model has converged and the difference between the numerical and analytical results is less than one per mil within the first ten modes. Table II shows the values for the natural frequencies of the first 10 bending modes in comparison to the FE-model. Figure 2 shows the corresponding mode shapes of the first five modes.

The influence of gravity will cause the horizontally orientated plate to sag. Since all edges are rigidly supported, the largest displacement will occur in the middle of the plate. A value of 9.81 m/s^2 for gravity will cause the plate to deflect 4.5 mm in the nonlinear simulation. The use of a linear calculation leads to a much larger deflection of 16.3 mm, which is more than 3.5 times higher. This remarkable difference is a consequence of the different approaches used for the computations:

In the linear simulation Approach 2 the stiffness matrix is derived from the undeformed geometry before applying the load. The deformed configuration is derived according to Equation (2) by calculating the equilibrium between the external loads (here: gravity) and the restoring forces.

In the nonlinear approach (Approach 3) the load is applied in small increments and the stiffness matrix is recalculated iteratively, by this taking into account the changing of the geometry and the influence of the gravity-induced stress. Since the lateral stiffness of a thin plate is very low, it will undergo a comparatively large deformation if a lateral force is applied. The large deformation renders a geometrical nonlinearity which needs to be accounted for in the model. Figure 3 shows the deformation and stress distribution of the rigidly supported plate under the influence of gravity in a linear and in a nonlinear simulation.

When performing the modal analysis, in the nonlinear approach the updated system matrices are used, by this

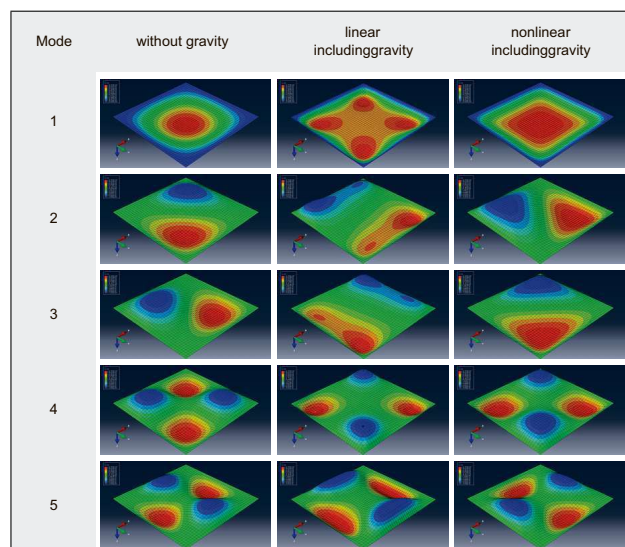

Figure 2. Plate with rigidly supported edges - the influence of gravity on the mode shapes.

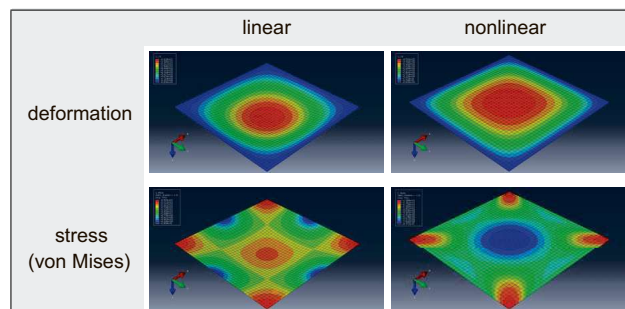

Figure 3. Plate with rigidly supported edges - comparison of the deformation and stress distribution due to gravity in a linear and a nonlinear simulation.

taking into account the deformed geometry. The stiffening effect due to gravity induced in-plane stress is accounted for by adding a load-stiffness matrix, as describe above. In the linear approach, the modal analysis is also performed on the deformed geometry, but the stress caused by gravity is ignored.

Table II shows the influence of gravity on the first 10 natural frequencies of the plate and also a comparison of the nonlinear and the linear approach. One can state that

taking gravity into account leads to a significant increase of the natural frequencies, while in the linear approach that increase is even larger than in the nonlinear approach. In addition to the significantly changes in the natural frequencies, Figure 2 shows that there are also changes in the mode shapes.

At this point, an engineer might be interested in knowing if the significant difference between Approaches 2 and 3 will lessen with increasing thickness of the plate. Or, more generally speaking: Is there a certain thickness at which the influence of gravity can be completely neglected (Approach 1)? To address this topic, a parametric study has been conducted, in which the thickness of the plate varies between 1 and 5 mm. Figure 4 compares the difference of the natural frequencies computed by Approaches 2 and 3 towards the analytical solution which completely neglects gravity. The complete results of the parametric study are given in Tables III–IX.

The results of the parametric study, represented in Figure 4, can be summarized as follows:

- The influence of gravity on the modal parameters strongly depends on the thickness of the plate. In the current example, the influence of gravity is significant and cannot be ignored when the plate thickness lies below 3 mm. Above a thickness of 4 mm, the difference towards an approach completely neglecting gravity is less than one percent – an error which is acceptable in most real world simulations.
- Approaches 2 and 3 which take into account gravity result in increased values of the natural frequencies. The difference towards neglecting gravity is highest in the first mode.
- Approaches 2 and 3 show the same qualitative behavior, meaning a significant decrease in the influence of gravity with increasing plate thickness. The difference in the results of the two approaches is considerably large at a plate thickness of 1 mm, but becomes irrelevant when the thickness is larger than 2 mm.

The afore mentioned results of the parametric study are valid for the given application example of a rectangular, simply supported plate. It might be reasonable to assume, that the influence of gravity on modal parameters will generally decrease with increasing thickness of (plate-like) structures. One should not, however, transfer the above mentioned absolute thickness values, at which gravity can be ignored, towards other problems without further considerations.

The current paper addresses the influence of gravity on a purely numerical level. A validated method to provide simply supported boundary conditions in an experimental setup is provided in [25].

3.3. Horizontally suspended plate

Figure 1 (center) shows the test example that will be discussed next: The plate is suspended in a horizontal position with four soft springs attached to the four corners. The stiffness of the springs in the model is chosen to be $1e-3$ N/mm, the transverse rigidity of the springs is set

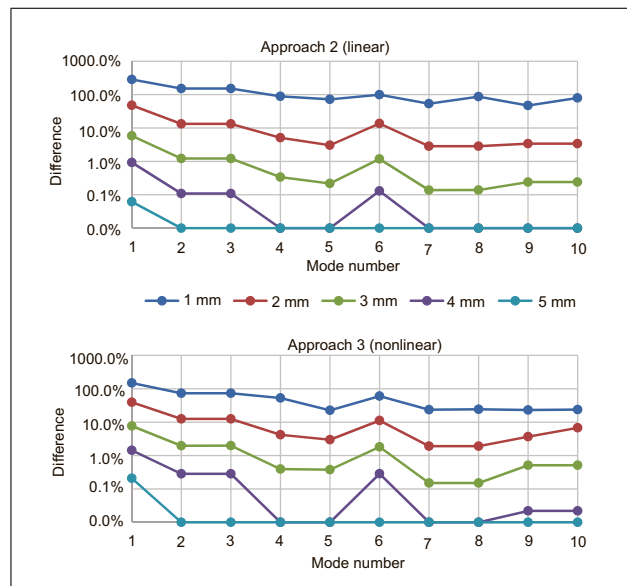

Figure 4. Plate with rigidly supported edges - the influence of gravity on the natural frequencies for different thicknesses ².

to $1e-4$ N/mm. Of course, this is an unrealistically low stiffness value that cannot be realized in an experiment in the real world, since it would require the use of strings that are capable of providing an elongation of approximately 19.5 meters under the given mass of the plate of 7.8 kg. The reason behind choosing such a low stiffness is to show that, even if the influence from the added stiffness of the suspension on the modal parameters can be ignored, gravity-induced stress and deformation still might lead to large changes.

First, the natural frequencies are calculated in real free-free conditions, so without the springs and without the influence of gravity. Then, the springs are added, still not taking into account gravity. The natural frequencies are reported in Table III, while Figure 5 shows the corresponding mode shapes.

As can be seen, the very soft springs do not influence the natural frequencies of the first 16 modes. The first six modes of the plate with the soft springs can still be treated as rigid body modes, and the ratio between the lowest structural mode and the highest rigid body mode is larger than five or even ten.

With springs only in the four corners, the influence of gravity is much stronger than with rigidly supported edges as boundary conditions. In the nonlinear simulation the lateral deflection is 52 mm, measured as the distance between the corners and the middle of the plate. In the linear approach the deflection is 102 mm, so almost twice as much. Figure 6 shows the deformation and stress distribution under the influence of gravity.

When discussing the influence of gravity on the modal parameters, unlike the case of rigidly supported edges,

² In order to use a logarithmic scaling of the vertical axis, very small negative values have been rounded close to zero. The exact results are given in Tables III–IX.

Table III. Horizontally suspended plate - the influence of gravity on the natural frequencies.

| Mode | without gravity | | including gravity | |
|------|-----------------|----------------|-----------------------|--------------------------|
| | free-free FEM | hor. susp. FEM | hor. susp. (FEM) lin. | hor. susp. (FEM) nonlin. |
| 1 | 0.0 Hz | 0.0 Hz | 0.0 Hz | 0.0 Hz |
| 2 | 0.0 Hz | 0.0 Hz | 0.0 Hz | 0.0 Hz |
| 3 | 0.0 Hz | 0.1 Hz | 0.0 Hz | 0.1 Hz |
| 4 | 0.0 Hz | 0.1 Hz | 0.1 Hz | 0.1 Hz |
| 5 | 0.0 Hz | 0.2 Hz | 0.2 Hz | 0.5 Hz |
| 6 | 0.0 Hz | 0.2 Hz | 0.2 Hz | 0.5 Hz |
| 7 | 3.4 Hz | 3.4 Hz | 4.2 Hz | 2.4 Hz |
| 8 | 4.9 Hz | 4.9 Hz | 5.0 Hz | (*) |
| 9 | 6.0 Hz | 6.1 Hz | 9.9 Hz | 8.7 Hz |
| 10 | 8.7 Hz | 8.7 Hz | 9.9 Hz | 8.7 Hz |
| 11 | 8.7 Hz | 8.7 Hz | 11.6 Hz | 11.0 Hz |
| 12 | 15.2 Hz | 15.2 Hz | 17.2 Hz | 17.3 Hz |
| 13 | 15.2 Hz | 15.2 Hz | 21.6 Hz | 21.0 Hz |
| 14 | 15.9 Hz | 15.9 Hz | 21.6 Hz | 21.0 Hz |
| 15 | 17.2 Hz | 17.2 Hz | 26.9 Hz | 23.3 Hz |
| 16 | 19.2 Hz | 19.2 Hz | 32.9 Hz | 32.3 Hz |

there are different results in principal between the linear and the nonlinear approach. While the linear approach, like before, leads to a general increase in the natural frequencies due to gravity, the nonlinear approach shows something different. Here, a frequency drop in the natural frequencies of the first two structural modes (modes number seven and eight) can be observed. Actually, the nonlinear approach renders an anomaly: The simulation results in a negative eigenvalue for what would normally be mode number eight (marked with an asterisk), indicating that the system is not stable. To further investigate this phenomenon, in addition to the gravity load, a lateral force of one Newton was applied to the middle of one of the plate's sides, as indicated in Figure 7.

This extra force causes the plate to take on a different deformed configuration – different from what could be seen in Figure 6. Interestingly, the plate stays in that configuration, even after the extra force has been removed again. Obviously, the gravity induced in-plane stress causes a buckling problem, or more general, it renders an elastic instability. This instability allows the plate to take on one of three possible configurations when gravity is applied. A small lateral force - or more generally an infinitesimal disturbance - can cause the plate to change between these configurations. Since the plate stays in that configuration even after the extra force is removed, some authors do not speak of an instability, but call it a *neutral equilibrium* [26], meaning that a plate in neutral equilibrium is neither stable nor unstable.

3.4. Vertically suspended plate

In another configuration the plate is hung up vertically with soft springs in the upper two corners, like indicated in

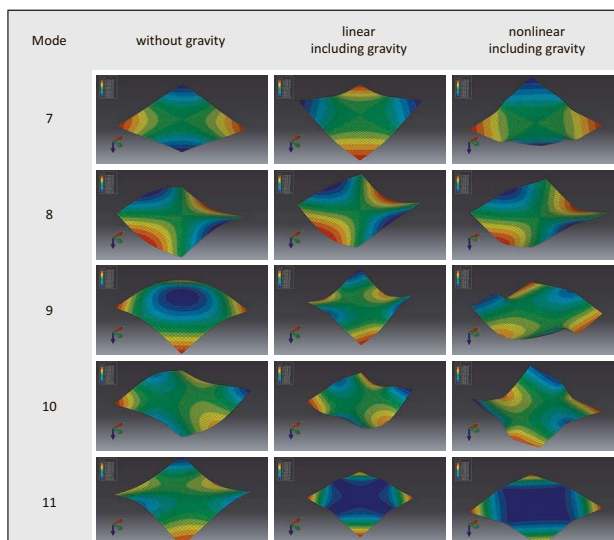

Figure 5. Plate horizontally suspended in soft springs - the influence of gravity on the mode shapes.

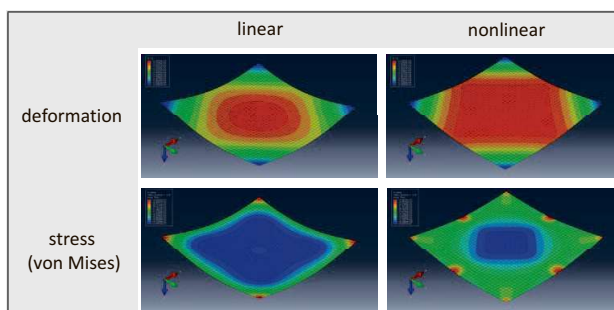

Figure 6. Plate horizontally suspended – comparison of the deformation and stress distribution due to gravity in a linear and a nonlinear simulation.

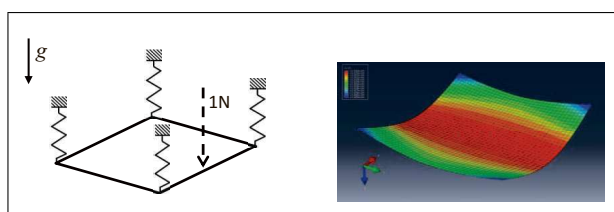

Figure 7. Alternative deformed configuration when applying gravity in the nonlinear approach.

the right picture of Figure 1. The results are summarized in Table IV, Figure 8 and Figure 9.

Before considering the influence of gravity, the first thing to notice when looking at the results for the natural frequencies is that the suspending springs again do not influence the structural modes of the plate. Gravity is now acting in the in-plane direction of the plate, and as can be seen, the influence is now much less severe than in the horizontal position. Concerning the linear approach, there is in fact no noticeable influence, respecting the given precision. This is due to the much higher in-plane stiffness of the plate compared to its lateral stiffness, thus leading to much smaller deformations. In fact, the deformations are

Table IV. Vertically suspended plate – the influence of gravity on the natural frequencies.

| Mode | without gravity | | including gravity | |
|------|-----------------|----------------|-----------------------|--------------------------|
| | free-free FEM | hor. susp. FEM | hor. susp. (FEM) lin. | hor. susp. (FEM) nonlin. |
| 1 | 0.0 Hz | 0.0 Hz | 0.0 Hz | 0.0 Hz |
| 2 | 0.0 Hz | 0.0 Hz | 0.0 Hz | 0.0 Hz |
| 3 | 0.0 Hz | 0.0 Hz | 0.0 Hz | 0.0 Hz |
| 4 | 0.0 Hz | 0.1 Hz | 0.1 Hz | 0.1 Hz |
| 5 | 0.0 Hz | 0.1 Hz | 0.1 Hz | 0.9 Hz |
| 6 | 0.0 Hz | 0.1 Hz | 0.1 Hz | 1.1 Hz |
| 7 | 3.4 Hz | 3.4 Hz | 3.4 Hz | 3.7 Hz |
| 8 | 4.9 Hz | 4.9 Hz | 4.9 Hz | 4.9 Hz |
| 9 | 6.0 Hz | 6.0 Hz | 6.0 Hz | 6.5 Hz |
| 10 | 8.7 Hz | 8.7 Hz | 8.7 Hz | 8.7 Hz |
| 11 | 8.7 Hz | 8.7 Hz | 8.7 Hz | 9.2 Hz |
| 12 | 15.2 Hz | 15.2 Hz | 15.2 Hz | 15.2 Hz |
| 13 | 15.2 Hz | 15.2 Hz | 15.2 Hz | 15.5 Hz |
| 14 | 15.9 Hz | 15.9 Hz | 15.9 Hz | 16.3 Hz |
| 15 | 17.2 Hz | 17.2 Hz | 17.2 Hz | 17.3 Hz |
| 16 | 19.2 Hz | 19.2 Hz | 19.2 Hz | 19.8 Hz |

Table V. Softly suspended cubic box – the influence of gravity on the natural frequencies.

| Mode | without gravity | | including gravity | |
|------|-----------------|----------------|-----------------------|--------------------------|
| | free-free FEM | hor. susp. FEM | hor. susp. (FEM) lin. | hor. susp. (FEM) nonlin. |
| 1 | 0.0 Hz | 0.0 Hz | 0.0 Hz | 0.0 Hz |
| 2 | 0.0 Hz | 0.0 Hz | 0.0 Hz | 0.0 Hz |
| 3 | 0.0 Hz | 0.0 Hz | 0.0 Hz | 0.0 Hz |
| 4 | 0.0 Hz | 0.1 Hz | 0.1 Hz | 0.1 Hz |
| 5 | 0.0 Hz | 0.1 Hz | 0.1 Hz | 0.7 Hz |
| 6 | 0.0 Hz | 0.1 Hz | 0.1 Hz | 0.7 Hz |
| 7 | 6.3 Hz | 6.3 Hz | 7.0 Hz | 6.4 Hz |
| 8 | 6.4 Hz | 6.4 Hz | 8.5 Hz | 7.8 Hz |
| 9 | 7.6 Hz | 7.6 Hz | 8.6 Hz | 7.9 Hz |
| 10 | 7.7 Hz | 7.7 Hz | 8.7 Hz | 8.3 Hz |
| 11 | 8.1 Hz | 8.1 Hz | 14.6 Hz | 13.7 Hz |
| 12 | 9.0 Hz | 9.0 Hz | 15.9 Hz | 14.4 Hz |
| 13 | 13.7 Hz | 13.7 Hz | 16.0 Hz | 14.8 Hz |
| 14 | 13.9 Hz | 13.9 Hz | 16.1 Hz | 15.2 Hz |
| 15 | 14.0 Hz | 14.0 Hz | 17.0 Hz | 15.6 Hz |
| 16 | 14.5 Hz | 14.5 Hz | 17.5 Hz | 15.6 Hz |

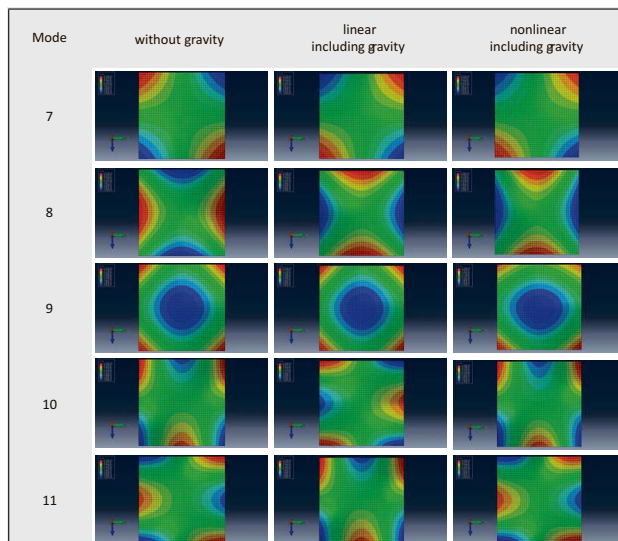

Figure 8. Plate vertically suspended in soft springs – the influence of gravity on the mode shapes.

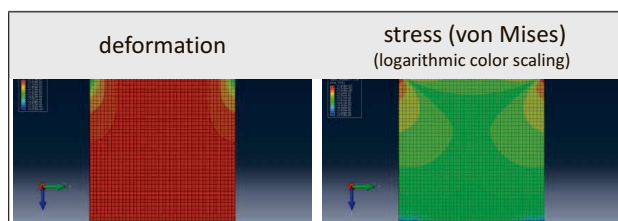

Figure 9. Plate vertically suspended – deformation and stress distribution.

so small that the linear and the nonlinear approach produce the same results concerning deformation and stress distribution. This is very interesting, because it means that the differences in the natural frequencies between the linear

and the nonlinear approach result solely from taking into account the stress distribution in the nonlinear approach while ignoring it in the linear simulation.

Another fact worth noticing with regard to the orientation of the plate is the different influence of gravity on the double modes. When the plate is horizontally orientated, the presence of gravity leads to a stress distribution of cyclic symmetry, thereby influencing both modes of the corresponding couple in the same way. Consequentially, the natural frequencies and mode shapes are changed by the same amount when compared to the case in which gravity is not present. If, however, the plate is hung up vertically, the stress distribution resulting from gravity shows merely one axis of symmetry, thereby splitting up the former double mode. The effect can only be seen in the nonlinear approach, and even there the influence on the natural frequencies and mode shapes is rather small. To give a numerical example: Modes number 10 and 11 in Table IV represent a double mode with a natural frequency of 8.7 Hz. The presence of gravity leaves the frequency of mode 10 unchanged (within the given precision) but increases the frequency of mode 11 to 9.2 Hz.

According to the results above, it might be reasonable to hang up thin-walled plates vertically when performing an EMA (like done i.e. in [27] and [28]), if gravity is intended to be ignored in the simulation model. By doing this, the influence of gravity on the modal parameters is much smaller and the setup is closer to free-free conditions.

4. Investigation of a cubic box

The last example consists of a hollow cube with an edge length of 1 m and a wall-thickness of 1 mm. To prevent

Table VI. Simply supported plate, thickness $h = 2$ mm.

| Mode | without gravity | | | including gravity | | | |
|------|-----------------|---------|------------|-------------------|------------|-----------|------------|
| | Analytical | FEM | Difference | linear | Difference | nonlinear | Difference |
| 1 | 9.8 Hz | 9.8 Hz | -0.09% | 14.5 Hz | 48% | 13.7 Hz | 40% |
| 2 | 24.6 Hz | 24.6 Hz | -0.06% | 27.9 Hz | 13% | 27.7 Hz | 13% |
| 3 | 24.6 Hz | 24.6 Hz | -0.06% | 27.9 Hz | 13% | 27.7 Hz | 13% |
| 4 | 39.3 Hz | 39.3 Hz | -0.09% | 41.4 Hz | 5% | 41.0 Hz | 4% |
| 5 | 49.2 Hz | 49.2 Hz | -0.04% | 50.7 Hz | 3% | 50.6 Hz | 3% |
| 6 | 49.2 Hz | 49.2 Hz | -0.04% | 55.9 Hz | 14% | 54.7 Hz | 11% |
| 7 | 63.9 Hz | 63.9 Hz | -0.08% | 65.7 Hz | 3% | 65.1 Hz | 2% |
| 8 | 63.9 Hz | 63.9 Hz | -0.08% | 65.7 Hz | 3% | 65.1 Hz | 2% |
| 9 | 83.6 Hz | 83.6 Hz | -0.03% | 86.4 Hz | 3% | 86.7 Hz | 4% |
| 10 | 83.6 Hz | 83.6 Hz | -0.03% | 86.4 Hz | 3% | 89.3 Hz | 7% |

Table VII. Simply supported plate, thickness $h = 3$ mm.

| Mode | without gravity | | | including gravity | | | |
|------|-----------------|----------|------------|-------------------|------------|-----------|------------|
| | Analytical | FEM | Difference | linear | Difference | nonlinear | Difference |
| 1 | 14.8 Hz | 14.7 Hz | -0.14% | 15.6 Hz | 5.9% | 15.9 Hz | 7.7% |
| 2 | 36.9 Hz | 36.8 Hz | -0.09% | 37.3 Hz | 1.2% | 37.6 Hz | 2.0% |
| 3 | 36.9 Hz | 36.8 Hz | -0.09% | 37.3 Hz | 1.2% | 37.6 Hz | 2.0% |
| 4 | 59.0 Hz | 58.9 Hz | -0.15% | 59.2 Hz | 0.3% | 59.2 Hz | 0.4% |
| 5 | 73.8 Hz | 73.7 Hz | -0.06% | 73.9 Hz | 0.2% | 74.0 Hz | 0.4% |
| 6 | 73.8 Hz | 73.7 Hz | -0.06% | 74.6 Hz | 1.2% | 75.1 Hz | 1.8% |
| 7 | 95.9 Hz | 95.8 Hz | -0.13% | 96.0 Hz | 0.1% | 96.0 Hz | 0.2% |
| 8 | 95.9 Hz | 95.8 Hz | -0.13% | 96.0 Hz | 0.1% | 96.0 Hz | 0.2% |
| 9 | 125.4 Hz | 125.3 Hz | -0.05% | 125.7 Hz | 0.2% | 126.0 Hz | 0.5% |
| 10 | 125.4 Hz | 12.3 Hz | -90.17% | 125.7 Hz | 0.2% | 126.0 Hz | 0.5% |

Table VIII. Simply supported plate, thickness $h = 4$ mm.

| Mode | without gravity | | | including gravity | | | |
|------|-----------------|----------|------------|-------------------|------------|-----------|------------|
| | Analytical | FEM | Difference | linear | Difference | nonlinear | Difference |
| 1 | 19.7 Hz | 19.6 Hz | -0.18% | 19.9 Hz | 0.9% | 20.0 Hz | 1.4% |
| 2 | 49.2 Hz | 49.1 Hz | -0.13% | 49.2 Hz | 0.1% | 49.3 Hz | 0.3% |
| 3 | 49.2 Hz | 49.1 Hz | -0.13% | 49.2 Hz | 0.1% | 49.3 Hz | 0.3% |
| 4 | 78.7 Hz | 78.5 Hz | -0.20% | 78.6 Hz | -0.1% | 78.6 Hz | -0.1% |
| 5 | 98.3 Hz | 98.3 Hz | -0.09% | 98.3 Hz | 0.0% | 98.3 Hz | 0.0% |
| 6 | 98.3 Hz | 98.3 Hz | -0.09% | 98.5 Hz | 0.1% | 98.6 Hz | 0.3% |
| 7 | 127.8 Hz | 127.6 Hz | -0.19% | 127.7 Hz | -0.1% | 127.7 Hz | -0.1% |
| 8 | 127.8 Hz | 127.6 Hz | -0.19% | 127.7 Hz | -0.1% | 127.7 Hz | -0.1% |
| 9 | 167.2 Hz | 167.0 Hz | -0.09% | 167.1 Hz | 0.0% | 167.2 Hz | 0.0% |
| 10 | 167.2 Hz | 167.0 Hz | -0.09% | 167.1 Hz | 0.0% | 167.2 Hz | 0.0% |

Table IX. Simply supported plate, thickness $h = 5$ mm.

| Mode | without gravity | | | including gravity | | | |
|------|-----------------|----------|------------|-------------------|------------|-----------|------------|
| | Analytical | FEM | Difference | linear | Difference | nonlinear | Difference |
| 1 | 24.6 Hz | 24.5 Hz | -0.23% | 24.6 Hz | 0.1% | 24.6 Hz | 0.2% |
| 2 | 61.5 Hz | 61.4 Hz | -0.16% | 61.4 Hz | -0.1% | 61.4 Hz | -0.1% |
| 3 | 61.5 Hz | 61.4 Hz | -0.16% | 61.4 Hz | -0.1% | 61.4 Hz | -0.1% |
| 4 | 98.3 Hz | 98.1 Hz | -0.26% | 98.1 Hz | -0.2% | 98.1 Hz | -0.2% |
| 5 | 122.9 Hz | 122.8 Hz | -0.12% | 122.8 Hz | -0.1% | 122.8 Hz | -0.1% |
| 6 | 122.9 Hz | 122.8 Hz | -0.12% | 122.9 Hz | -0.1% | 122.9 Hz | 0.0% |
| 7 | 159.8 Hz | 159.4 Hz | -0.25% | 159.4 Hz | -0.2% | 159.4 Hz | -0.2% |
| 8 | 159.8 Hz | 159.4 Hz | -0.25% | 159.4 Hz | -0.2% | 159.4 Hz | -0.2% |
| 9 | 209.0 Hz | 208.7 Hz | -0.12% | 208.8 Hz | -0.1% | 208.8 Hz | -0.1% |
| 10 | 209.0 Hz | 208.7 Hz | -0.12% | 208.8 Hz | -0.1% | 208.8 Hz | -0.1% |

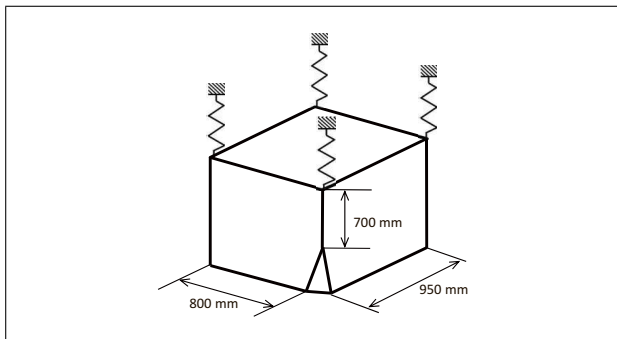

Figure 10. Cubic box: softly suspended.

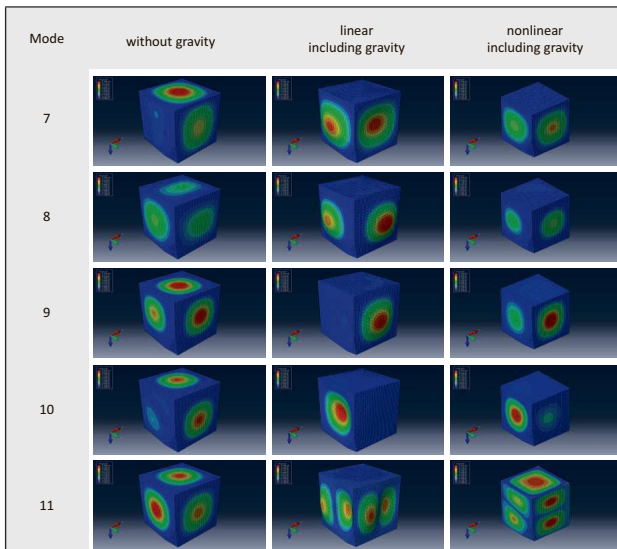

Figure 11. Hollow cube suspended in soft springs – the influence of gravity on the mode shapes.

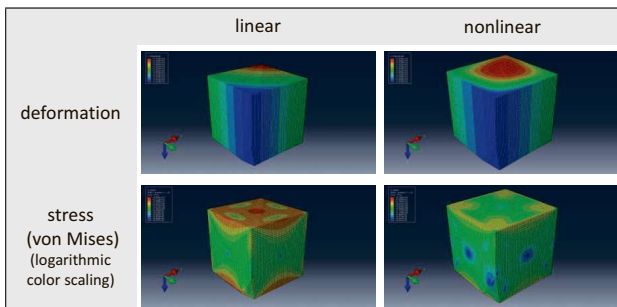

Figure 12. Box suspended in soft springs – comparison of the deformation and stress distribution due to gravity in a linear and a nonlinear simulation.

too many multiple modes, one edge has been modified according to Figure 10 to slightly break up symmetry. The cube is suspended in soft springs at the four upper corners. Since the cube is approximately six times heavier than the plate in the previous examples, the spring stiffness has been modified to $6e-3$ N/mm and the transverse rigidity to $6e-4$ N/mm accordingly.

The simulation results are summed up in Table V, Figure 11 and in Figure 12. First, disregarding gravity, it can be stated that the added stiffness of the suspending springs

does not influence the structural modes. Changes in the natural frequencies or in the mode shapes can therefore be attributed to gravity introduced stress.

Under the influence of gravity the natural frequencies of the structural modes rise in general, while the effect is stronger in the linear approach than in the nonlinear approach. With regard to the effect of gravity on the mode shapes, the following applies: If one considers the cubic box as an assembly of combined plates, the effect of gravity on plates that are orientated vertically is different from those in horizontal orientation. The plate at the top and at the bottom of the box experience, generally speaking, a larger amount of gravity induced stress. This has a significant influence on the mode shapes, as it can be interpreted as a further breakup of the structure’s symmetry. As a consequence, mode shapes are distorted when compared to the simulation ignoring gravity, mode switches occur and even new mode shapes appear. For example, Approaches 2 and 3, accounting for the presence of gravity, show in mode number 10 a mode shape that does not exist in the simulation results of Approach 1 which neglects the effects of gravity.

Conclusions

According to the results presented above, the following conclusions for thin-walled structures exposed to gravity can be drawn:

1. It is well known, that the presence of gravity plays an important role on the modal parameters, like the natural frequencies and even the mode shapes. For very thin plates, gravity induced in-plane stress might even lead to elastic instability.
2. Approaches taking into account gravity can result in increased as well as decreased values of the natural frequencies compared to approaches neglecting gravity. The difference can be significantly large. In the current application examples, differences of up to 285 percent could be observed. The influence of gravity, however, rapidly decreases with increased plate thickness.
3. In plate-like structures, the effect of gravity depends on the orientation of the structure. In order to be closer to free-free conditions in the experimental setup, it is reasonable to hang up the test object in such a way, that gravity acts in-plane. By doing this, the influence of gravity on the modal parameters is much smaller.
4. In general, it is a good idea to consider gravity and the orientation of the test object in the theoretical model to be in accordance with the experimental setup.
5. Gravity can cause large deflections in thin-walled structures, rendering a strong geometric nonlinearity, causing linear and nonlinear simulations to produce very different results.

References

[1] N. Maia, J. Silva: Theoretical and experimental modal analysis. Research Studies Press, 1997, (Engineering dynamics series).

- [2] S. Perinpanayagam, D. Ewins: Free-free, fixed or other test boundary conditions for the best modal test. 21st international modal analysis conference (IMAC-XXI), Kissimmee, FL, 2003.
- [3] D. Ewins: Modal testing: theory, practice, and application. Research Studies Press, 2000, (Mechanical engineering research studies: Engineering dynamics series).
- [4] E. F. Crawley, M. S. Barlow, M. C. van Schoor, B. Masters, A. S. Bixos: Measurement of the modal parameters of a space structure in zero gravity. *Journal of Guidance, Control, and Dynamics* **18** (1995) 385–394.
- [5] L. Virgin, D. Holland: Effect of weight on the experimental modal analysis of slender cantilever beams. ASME 2009 International Design Engineering Technical Conferences and Computers and Information in Engineering Conference, 2009, American Society of Mechanical Engineers, 557–560.
- [6] A. W. Leissa: *Vibration of shells*. Vol. 288. Scientific and Technical Information Office, National Aeronautics and Space Administration Washington, DC, USA, 1973.
- [7] A. W. Leissa: *Vibration of plates*. Tech. Rept. DTIC Document, 1969.
- [8] M. Qatu, A. Leissa: Buckling or transverse deflections of unsymmetrically laminated plates subjected to in-plane loads. *Aiaa Journal* **31** (1993) 189–194.
- [9] S. Marburg, H.-J. Beer, J. Gier, H.-J. Hardtke, R. Rennert, F. Perret: Experimental verification of structural–acoustic modeling and design optimization. *Journal of Sound and Vibration* **252** (2002) 591–615.
- [10] J. Farkas, K. Jarmai: *Design and optimization of metal structures*. Elsevier Science, 2008, (Woodhead Publishing Series in Civil and Structural Engineering).
- [11] J. K. Paik, B. J. Kim: Ultimate strength formulations for stiffened panels under combined axial load, in-plane bending and lateral pressure: a benchmark study. *Thin-Walled Structures* **40** (2002) 45–83.
- [12] C. Ross: *Pressure vessels under external pressure: Statics and dynamics*. Elsevier Applied Science, 1990, (Elsevier Applied Science).
- [13] C. Ross, P. Haynes, W. Richards: Vibration of ring-stiffened circular cylinders under external water pressure. *Computers & structures* **60** (1996) 1013–1019.
- [14] S. Kendrick: The buckling under external pressure of circular cylindrical shells with evenly spaced, equal strength circular ringframes. Naval Construction Research Establishment Report **211** (1953) 1953.
- [15] C.-F. Shih, J. C. Chen, J. Garba: Vibration of a large space beam under gravity effect. *AIAA journal* **24** (1986) 1213–1216.
- [16] T. Yokoyama: Vibrations of a hanging timoshenko beam under gravity. *Journal of Sound and Vibration* **141** (1990) 245–258.
- [17] J. Xiang, S. Zhao, D. Li: A model updating method considering the complex mechanical environment. *Results in physics* **6** (2016) 530–533.
- [18] S. Ilanko, S. Dickinson: The vibration and post-buckling of geometrically imperfect, simply supported, rectangular plates under uni-axial loading, part I: Theoretical approach. *Journal of Sound and Vibration* **118** (1987) 313–336.
- [19] S. Ilanko, S. Dickinson: The vibration and post-buckling of geometrically imperfect, simply supported, rectangular plates under uni-axial loading, part II: Experimental investigation. *Journal of Sound and Vibration* **118** (1987) 337–351.
- [20] Dassault Systèmes: *Abaqus product documentation: Theory guide*, release 6.14. 2016.
- [21] K. Bathe: *Finite element procedures*. Klaus-Jürgen Bathe, 2014.
- [22] J. Bonet, R. Wood: *Nonlinear continuum mechanics for finite element analysis*. Cambridge University Press, 2008.
- [23] N. A. Lieven, P. Greening: Effect of experimental pre-stress and residual stress on modal behaviour. *Philosophical Transactions of the Royal Society of London A: Mathematical, Physical and Engineering Sciences* **359** (2001) 97–111.
- [24] T. Kiesel: *Flexible multi-body simulation of a complex rotor system using 3d solid finite elements*. Dissertation. Technical University of Munich, 2017.
- [25] O. Robin, J.-D. Chazot, R. Boulandet, M. Michau, A. Berry, N. Atalla: A plane and thin panel with representative simply supported boundary conditions for laboratory vibroacoustic tests. *Acta Acustica united with Acustica* **102** (2016) 170–182.
- [26] E. Ventsel, T. Krauthammer: *Thin plates and shells: Theory: Analysis, and applications*. CRC Press, 2001.
- [27] K. Sepahvand, S. Marburg: On construction of uncertain material parameter using generalized polynomial chaos expansion from experimental data. *Procedia IUTAM* **6** (2013) 4–17.
- [28] K. Sepahvand, S. Marburg: Identification of composite uncertain material parameters from experimental modal data. *Probabilistic Engineering Mechanics* **37** (2014) 148–153.