Simulation of AVAS for Prototypes using FE and PML

N. Schönfeld¹, S. Gsell², G. Müller³

¹ *Technical University of Munich, Chair of Structural Mechanics, 80333 Munich, Germany, E-Mail: nils.schoenfeld@tum.de*

² *AUDI AG, 85057 Ingolstadt, Deutschland, E-Mail: stephan.gsell@audi.de*

³ *Technical University of Munich, Chair of Structural Mechanics, 80333 Munich, Germany, E-Mail: gerhard.mueller@tum.de*

Abstract

Electric vehicles, known for their quiet operation, can pose safety risks at low speeds due to their silence without traditional combustion engine sounds. To address this, many countries require Acoustic Vehicle Alerting Systems (AVAS), which emit sounds to alert pedestrians. AVAS sound testing is conducted with microphones placed 2 meters from the vehicle, measuring sound in both stationary and driving states up to 31 km/h in North America. Correct loudspeaker placement ensures accurate transmission to measurement microphones, aiding in regulatory compliance.

To simulate AVAS sound transmission without a physical prototype, a digital model is created using the Finite Element Method (FEM) and a Perfectly Matched Layer (PML). This setup replicates real test conditions, predicting the sound transmission from the speaker in the engine bay to external microphones.

This study validates AVAS simulations against real vehicle data, demonstrating frequency ranges of alignment between simulation results and reference vehicle data for the Q6 e-tron. The transfer functions from these simulations will be used in Audi's e-Sound GUI, reducing dependency on prototypes and saving development time and resources.

Introduction

Electric vehicles are typically very quiet, particularly at lower speeds, due to the absence of traditional combustion noises. While this reduces noise pollution, it also creates a potential risk for pedestrians and cyclists who may not hear the vehicle approaching. To address this, global regulations require electric vehicles to emit artificial sounds. These sounds are produced by the Acoustic Vehicle Alerting System (AVAS), which is engineered to generate specific sound levels within certain frequency ranges depending on the vehicle's speed. According to the AVAS regulation of the Economic Commission for Europe of the United Nations (UNECE), in the user states acoustic support is required for vehicles at speeds up to 20 km/h [1]. In contrast, in the United States (USA), AVAS is mandated for speeds up to 31 km/h [2].

Vehicles must pass between two microphones positioned 2 meters from the vehicle's centerline and at a height of 1.2 meters on an outdoor noise test track [1][2]. For the USA, tests are conducted at speeds of 11 km/h, 21 km/h, and 31 km/h [2]. There are also additional stationary tests with both forward and reverse gears engaged [2]. Under UNECE legislation, noise measurements are required for forward movement at 10 km/h and 20 km/h and reverse movement at 6 km/h [1].

Measurements for homologation need to be taken outdoors, where the environmental conditions at the outside noise test track affect sound transmission. Data gathered over a one-year period enabled the assessment of frequency response functions and their dependence on various environmental parameters. This analysis, along with its influence on sound transmission, is further discussed in [3].

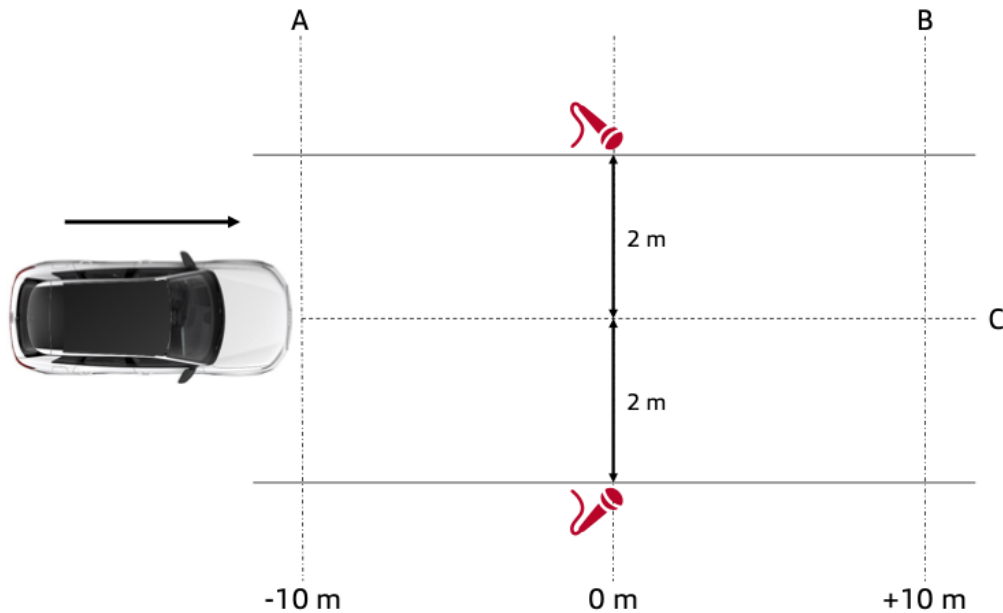

Figure 1: Measurement setup for a pass-through measurement according to [1] (adjusted)

The process of creating and fine-tuning an AVAS sound is iterative, requiring continuous measurements and adjustments. This cycle is repeated as often as needed to ensure the AVAS sound aligns with both the brand's subjective identity and the necessary legal regulations. [4]

To achieve a reliable assessment for future cars, optimal loudspeaker placement in the vehicle is crucial to ensure proper sound transmission to the measurement microphones. This process can begin early in development, before a physical vehicle prototype is available, by calculating sound transmission. These calculations provide valuable insights and support decisions on ideal speaker positions, allowing for the evaluation of different setups. A dependable method is required to ensure the accuracy of these results.

Goal

The goal of optimizing the loudspeaker placement is to achieve a consistent, ideally linear transmission across the desired frequency range. To capture the subjective identity of AUDI AG, a frequency range of at least 80 Hz to 1600 Hz is essential. In current car manufacturing at AUDI AG, speakers with a diameter of 13 cm and a volume of up to 3.5 liters are used to ensure sound transmission in the lower frequencies. These larger speaker enclosures must be carefully positioned inside the front engine bay. Achieving both a large speaker size and linear transmission requires understanding how sound travels from the speaker to the measurement microphones early in the development process. This early knowledge allows adjustments to be made, enabling the pre-tuning of AVAS sounds prior to the availability of real prototypes.

Setup

The AVAS loudspeaker is usually located in the front engine bay. To accurately calculate the sound transmission from the loudspeaker to the measurement microphone, several factors must be considered when setting up the model.

1. Sound field within the engine bay
2. Sound transmission through different components within and around the engine bay
3. Sound reflection from the street surface and



4. Sound transmission from outside the engine bay to the measurement microphones.

The AVAS regulation highlights a frequency range of interest that extends up to approximately 2000 Hz. Instead of focusing on the speaker as the sound source, this research utilizes the particle acceleration at the outer surface of the speaker grill as the primary input. The data used for this analysis has been verified and provided by the speaker manufacturer, referencing a specific speaker voltage. By employing this data, a transfer function can be derived to relate the speaker voltage to the sound pressure at the microphone location. This transfer function is then evaluated and compared to measurements taken from the real Audi Q6 e-tron [6].

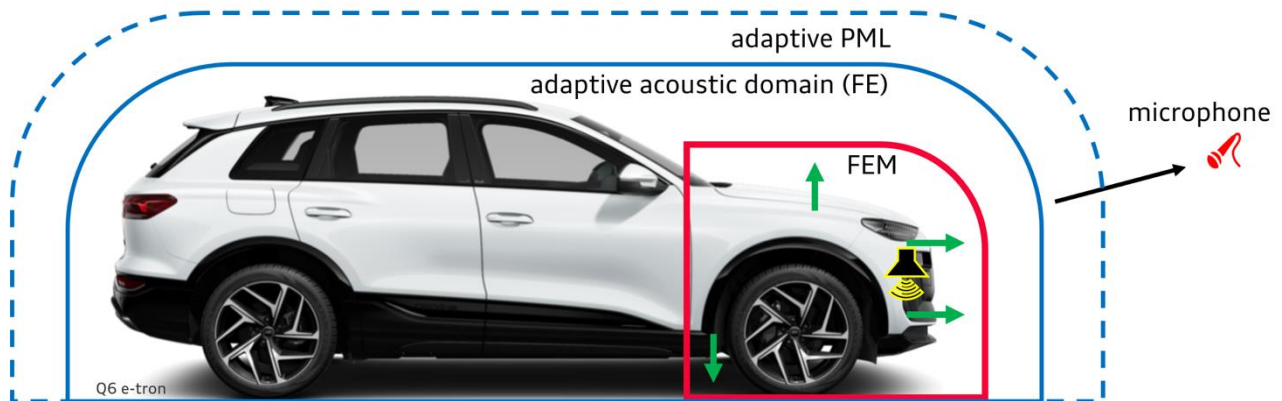

Figure 1: Visualization of simulation setup using different simulation methods to calculate the AVAS transmission on Audi Q6 e-tron [6].

For this study, the fluid (in this case, air) is fully meshed using Finite Elements (FE) to cover the internal cavities and gaps in the front engine bay completely. The red box visualizes this in Figure 2. The FE mesh encloses the entire front engine bay, extending down to the street surface and wrapping around the entire front exterior of the car. This comprehensive approach ensures that all gaps and openings in the car's outer surface are accounted for. For all relevant elements of the car exterior, the transmissions (green arrows in Figure 2) are accounted for by simplifying the metal and plastic sheets to single-layered FE structural subsystems. Those subsystems are then coupled to the FE mesh on both sides of those sheets. Some external cover elements such as the floor or the wheelhouses consist of an applied damping layer. The transmission of these materials can be calculated based on their properties using the transfer matrix method. Additionally, the street surface must be considered when capturing the complete acoustic environment around the car. In the initial approach, the street surface was assumed to be flat and rigid. A Perfectly Matched Layer (PML) is applied to the car's outer surface and the outer boundary of the FE cavity (acoustic surface). This setup establishes an infinite, non-reflective boundary, effectively simulating conditions similar to an outside noise test track without any external sound sources or reflective surfaces within a designated range. As illustrated in Figure 2, the outer surface of the car and the FE cavity boundary are first enclosed by an adaptive frequency-dependent FE mesh. An adaptive frequency-dependent PML is then attached, ensuring sound absorption into infinity. Since the measurement microphones are positioned outside the FE element cavity, the transmission from the PML surface to the examination points is calculated using the Kirchhoff integrals.

For additional information on FEM calculations, the transfer matrix technique and PML, refer to [7] to [18].

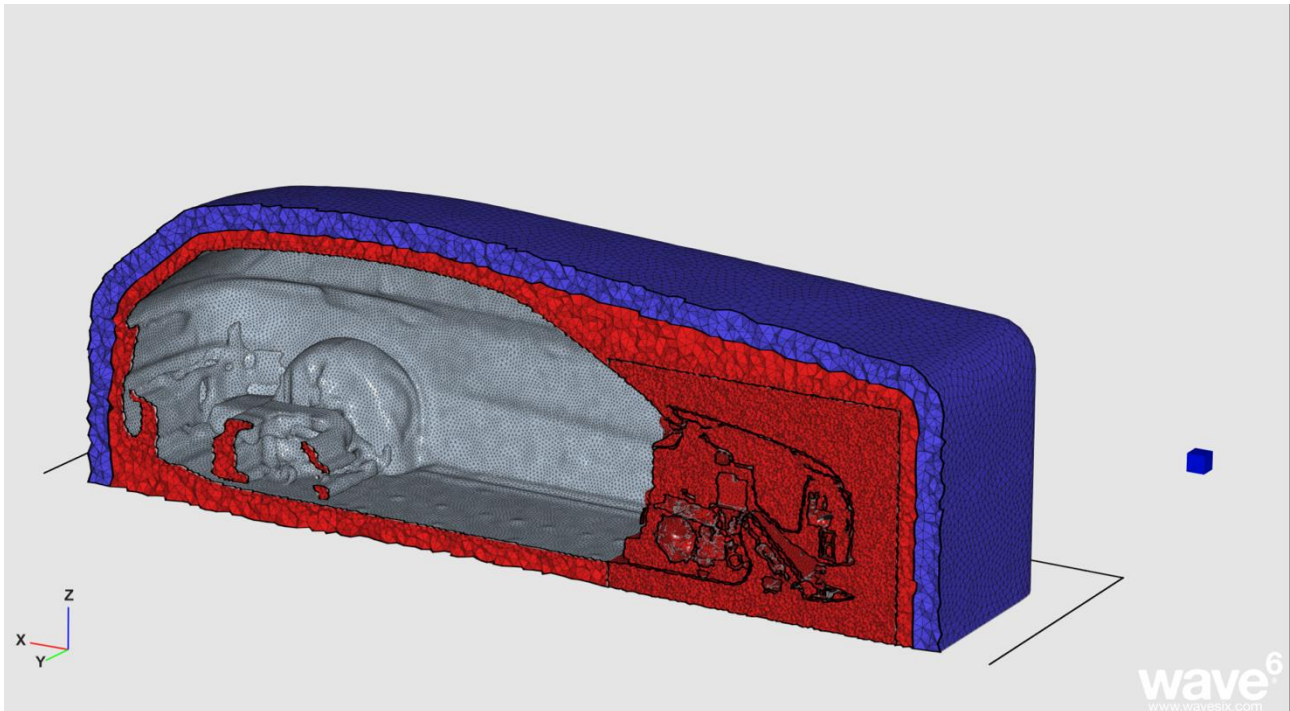

Figure 2: Visualization of the simulation setup in wave6 for calculating AVAS transmission on the Audi Q6 e-tron [5]. The red region shows the finite element (FE) mesh, which spans the front engine bay and the adaptive acoustic domain (for 1000 Hz). The blue wrap represents the adaptive perfectly matched layer (PML) tuned for 1000 Hz. On the right the blue cube marks the position of the front center measurement microphone regarding the AVAS measurement regulations.

In Figure 3, the setup is transferred and modeled using the commercial software wave6 [5]. The figure presents a slicing scene, with the slice taken at the car's centerline for visualization purposes. The model consists of an acoustic FE subsystem for the front engine bay area (shown in red in Figure 3), enclosing internal components and surrounding structures. The mesh is generated from the CAD model using wave6's wrapping and meshing functionalities. Starting from the acoustic surface mesh, aligned with the inner surface of the acoustic layer, the adaptive PML method then automatically creates both the acoustic domain (also depicted in red in Figure 3) and the PML (shown in blue in Figure 3). The size of the acoustic domain and the PML layer adapts depending on the frequency. In Figure 3 the presented adaptive acoustic domain and the adaptive PML are tuned for 1000 Hz. In the Audi Q6 e-tron [6], the AVAS speaker is located behind the front Audi logo, facing downward. In the model, this speaker is represented by a fluctuating velocity surface based on data from the speaker manufacturer. Additionally, an examination point, in Figure 3 represented as a blue cube, is placed on the right, symbolizing a measurement microphone. This point marks the position of the center front microphone, located 2 m in front of the car at a height of 1.2 m. This location is mandated by US AVAS regulations.

First results of calculated AVAS transmission

The initial phase of the analysis calculates discrete frequencies using a 1/12 octave spectrum. From these calculations, a transfer function is developed, representing the relationship between input and output signals. Specifically, this transfer function connects the voltage applied to the speaker with the resulting sound pressure measured at the microphone location. The input to the speaker system is based on data from the manufacturer detailing particle acceleration on a specific area of the speaker grill's exterior. This acceleration data is then applied to the FE mesh within the simulation setup (illustrated in Figure 3). The data also includes a reference voltage spectrum, which serves as the basis for determining the transfer function from speaker voltage to the microphone's sound pressure.



These measurements correspond to those initially taken by the manufacturer to provide accurate input parameters.

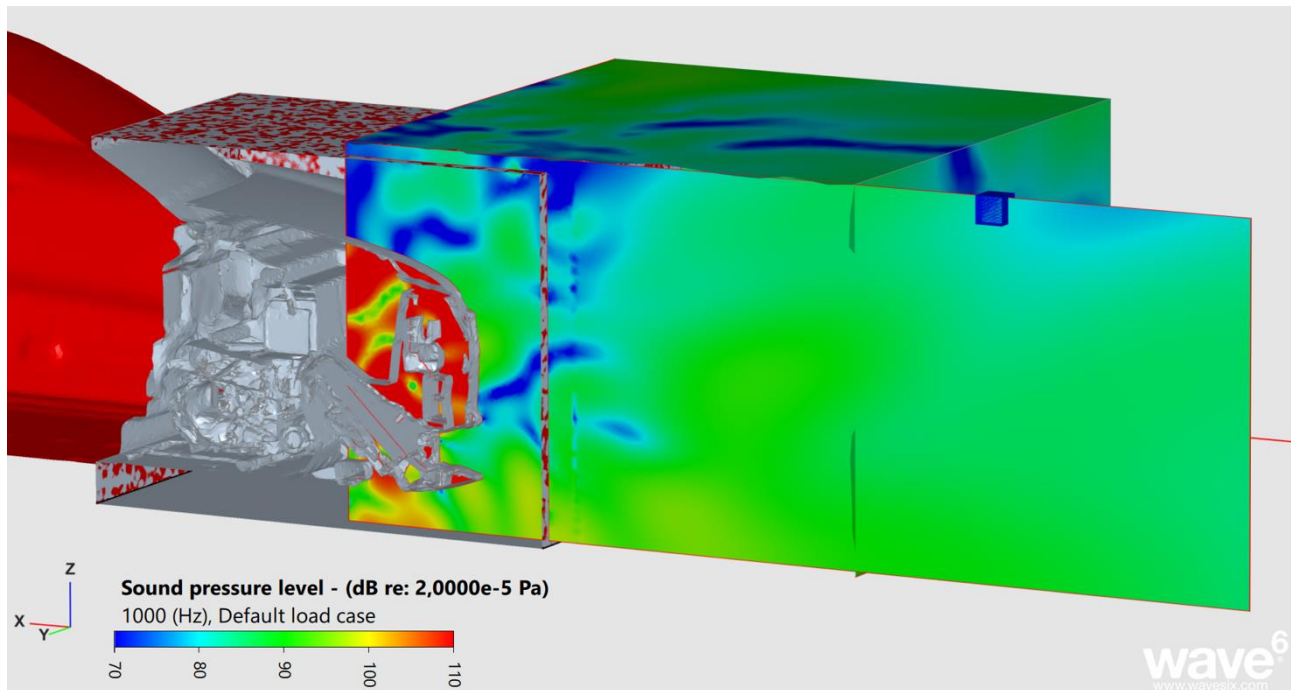

Figure 3: First results of the AVAS transmission for an Audi Q6 e-tron modeled using wave6 [5]. The findings at 1000 Hz are displayed. The grey FE mesh represents the model. The red area highlights the acoustic surface, while the blue cube on the right marks the position of the front center measurement microphone. The colored region represents the sound pressure level distribution along the car's central axis, both inside and outside the engine bay.

The distribution of sound pressure levels along the car's centerline at a frequency of 1000 Hz is illustrated in Figure 4. The grey area represents the FE mesh region, while the red area marks the acoustic surface. The color-coded sound pressure levels range from red (110 dB, high sound pressure level) to blue (70 dB, low sound pressure level), with red indicating the highest noise levels. High sound pressure appears in the front engine bay, where a mode is clearly identifiable in the interior, marked by alternating areas of high and low sound pressure extending across the evaluation zone. Sound transmission through exterior elements and reflections from the street surface influence the sound field in front of the vehicle, shown by the green/blue-shaded area. A lower sound pressure level of around 80 dB is observed at the examination point, represented by a blue cube on the right, indicated by a turquoise area in this setup.

Figure 5 presents the simulated transfer function of the Q6 e-tron AVAS using wave6 software. The simulation outcome is depicted as the transfer function that illustrates the relationship between the sound pressure at the microphone location and the speaker voltage, presented in blue. The result is presented in third octave bands across a frequency range of 125 Hz to 2000 Hz, encompassing key frequencies relevant to AVAS development. For comparison, two measurements of two different reference vehicles of the same type are shown in orange and yellow. This measurement was conducted on an outdoor noise test stand at AUDI AG, ensuring consistency in test conditions. The analysis reveals promising initial results, with several frequency bands exhibiting deviations of less than 3 dB. Clear transmission is evident particularly between 125 Hz and 315 Hz and in the frequency range from 800 to 2000 Hz. The frequency ranges of clear transmission for the lower frequencies are also evident in the transfer functions of the reference vehicles, despite a discernible offset. In the midrange, a satisfactory comparison is achieved. Additionally, the frequency range of satisfactory transmission

in the range of 800-1000 Hz is depicted, although the above range exhibits an overestimation of the later results.

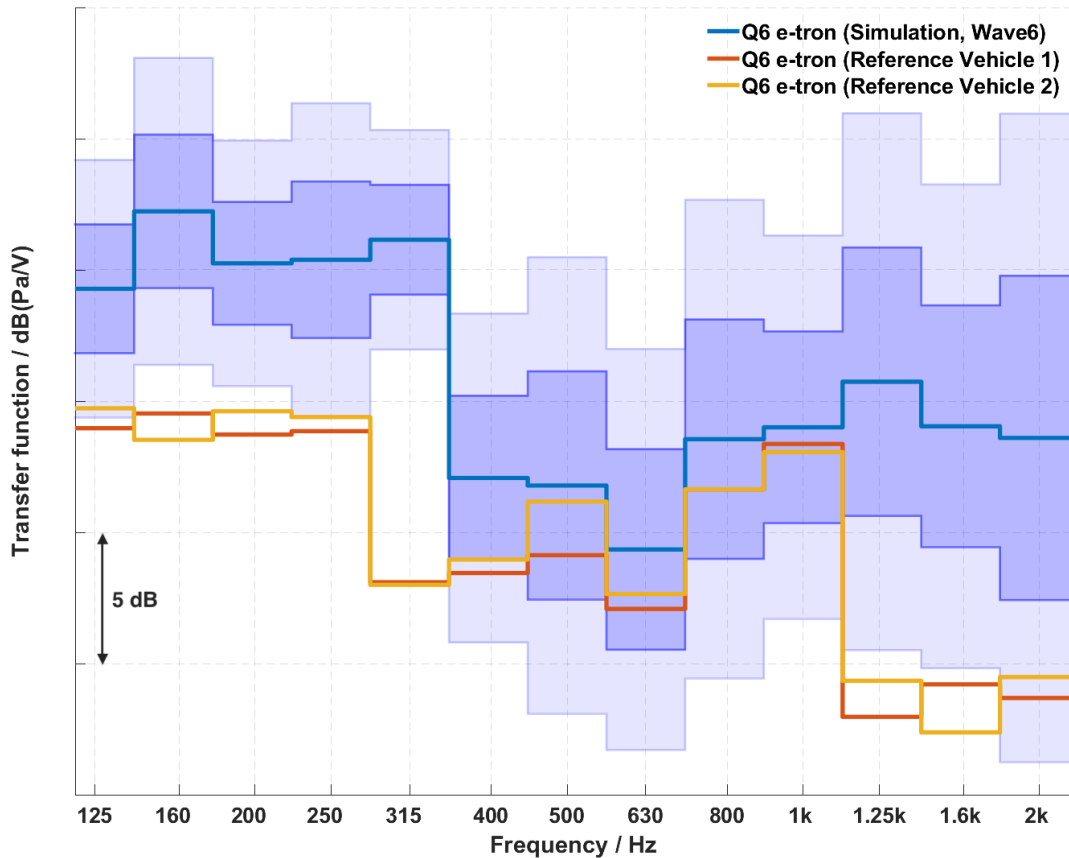

Figure 4: Comparison of Acoustic Simulation and Measurements of an Audi Q6 e-tron: The graph presents the first result of a simulation using wave6 [5] (blue) across the frequency range of 125 Hz to 2000 Hz third octave bands. The reference measurement of a real vehicle is shown in red and yellow. The blue shaded area highlights investigations into measurement spreads, including variations in series production, prototypes, and changes over time or due to use.

Further investigations have been conducted to address the variation that must be accounted for when measurements with prototypes are referenced. These spreads cannot be disregarded, as they arise from various sources: the measurement setup itself, the inherent variability in mass-produced vehicles, differences in prototypes, and changes in individual vehicles over time due to wear and use. This variation yields a standard deviation ranging from 3 dB to 5 dB, depending on frequency. For frequencies up to 400 Hz, a spread of 3 dB must be considered, while at higher frequencies (around 2000 Hz), this spread increases to about 5 dB. The standard deviation is applied to the blue line (dark blue area) representing the simulation results. Figure 5 displays six out of the thirteen third-octave bands, with measurements falling within this deviation range. Since the simulation result may not represent the mean value within this spread, a double standard deviation is shown as a light blue area to present the simulation result as both lower and upper spread boundaries. In Figure 5, even more third-octave bands of the measurement fall within at least the light blue area, indicating a good first estimation. The blue area marks an initial estimate of the expected future transfer function for the vehicle under consideration. This helps in assessing and evaluating the current speaker position and can serve as a basis for the later development of the AVAS sound.



Conclusion

This study demonstrates that it is possible to calculate the AVAS (Acoustic Vehicle Alerting System) transmission from the speaker to the measurement microphones using various techniques such as Finite Element (FE) analysis, transfer matrix calculation and the Perfectly Matched Layer (PML). While the first approach is already close to achieving good results, there are still some offsets when compared to real-world measurements. Despite these discrepancies, the simulation results demonstrate a range of good accuracy, staying within a double standard deviation corridor. This corridor accounts for variations derived from factors such as the measurement setup, the natural variability in mass-produced vehicles, differences among prototypes, and changes in individual vehicles over time due to wear and use. These simulations provide valuable insights into the transmission characteristics, although actual measurements still show significant variations that cannot be perfectly predicted. Despite these challenges, the study offers an overview of current performance of AVAS simulation and offers a basis for forecasting the transmission of future vehicles. This procedure allows for the evaluation of various speaker positions, helping to identify a good placement. These transfer functions can be incorporated into Audi's e-Sound GUI [4] software tool for testing, reducing the need for physical prototypes. This approach saves time and resources, allowing efficient AVAS integration across different vehicle configurations.

Acknowledgement

Nils Schönfeld: conceptualization, methodology, writing: original draft, writing: review and editing, visualization, software, validation

Stephan Gsell: conceptualization, methodology, writing: review and editing, validation

Gerhard Müller: conceptualization, writing: review and editing, supervision

Literature

- [1] Economic Commission for Europe of the United Nations (UNECE). Regulation No 138 of the Economic Commission for Europe of the United Nations (UNECE) — Uniform provisions concerning the approval of Quiet Road Transport Vehicles with regard to their reduced audibility [2017/71]. 05.10.2016. URL: <https://unece.org/fileadmin/DAM/trans/main/wp29/wp29regs/2017/R138r1e.pdf>, last checked: 05.11.2023.
- [2] National Highway Traffic Safety Administration, Federal Motor Vehicle Safety Standards. Minimum Sound Requirements for Hybrid and Electric Vehicles. NHTSA-2016-0125-0001. 14.12.2016. URL: <https://www.regulations.gov/document/NHTSA-2016-0125-0001>, last checked: 05.11.2023.
- [3] Nils Schönfeld, Stephan Gsell, Gerhard Müller. ISNVH 2024, Transmission of Sound under the Influence of Various Environmental Conditions on Short Distances. 12.06.2024. URL: <https://www.sae.org/content/2024-01-2933>, last checked: 02.10.2024.
- [4] Stephan Gsell, Michael Werner. AAC 2019 - Proceedings, Development of AVAS sounds at Audi. Aachener Akustik Kolloquium. 25.11.2019 - 27.11.2019. URL: <https://www.aachen-acoustics-colloquium.com/en/conference-documents/>
- [5] Dassault Systèmes, wave6. URL: <https://www.3ds.com/products/simulia/wave6>, last checked: 10.10.2024.
- [6] AUDI AG. Picture of Audi Q6 e-tron. Audi Mediacenter. URL: <https://www.audi.de/de/brand/de/neuwagen/q6-e-tron/q6-suv-e-tron.html>, last checked: 10.10.2024.
- [7] Manfred Kaltenbacher, editor. Computational Acoustics, volume 579 of CISM International Centre for Mechanical Sciences. Springer International Publishing, Cham, 2018.
- [8] Andreas Franck. Finite-Elemente-Methoden, Lösungsalgorithmen und Werkzeuge für die akustische Simulationstechnik. Number 9 in Aachener Beiträge zur Technischen Akustik. Logos-Verl, Berlin, 2009.



-
- [9] Dietrich Braess. *Finite Elemente: Theorie, schnelle Löser und Anwendungen in der Elastizitätstheorie*. Springer Berlin Heidelberg, Berlin, Heidelberg, 2013.
- [10] J.-F. Allard and N. Atalla, *Propagation of sound in porous media: modelling sound absorbing materials*, 2nd ed. Hoboken, N.J: Wiley, 2009. doi: 10.1002/9780470747339.
- [11] Alexander Peiffer. *DAGA 2018, Hybrid modelling of transmission loss with acoustic treatment*. 2018.
URL: https://pub.dega-akustik.de/DAGA_2018/data/articles/000587.pdf, last checked: 07.10.2024.
- [12] Alexander Peiffer. *Vibroacoustic Simulation: An Introduction to Statistical Energy Analysis and Hybrid Methods*. Wiley, 1 edition, May 2022.
- [13] Karin Tageman, Master's Thesis: *Modelling of sound transmission through multilayered elements using the transfer matrix method*. 2013.
URL: <https://odr.chalmers.se/server/api/core/bitstreams/e4e05949-42da-491f-a12c-6e234ba1c6dd/content>, last checked: 07.10.2024.
- [14] Reinhard Lerch, Gerhard Sessler, and Dietrich Wolf, *Technische Akustik*. Springer Berlin Heidelberg, 2009. doi: 10.1007/978-3-540-49833-9.
- [15] Jean-Pierre Berenger. A perfectly matched layer for the absorption of electromagnetic waves. *Journal of Computational Physics*, 114(2):185–200, October 1994.
- [16] Jean-Pierre Berenger. Perfectly matched layer for the FDTD solution of wave-structure interaction problems. *IEEE Transactions on Antennas and Propagation*, 44(1):110–117, January 1996.
- [17] Quan Qi and Thomas L. Geers. Evaluation of the Perfectly Matched Layer for Computational Acoustics. *Journal of Computational Physics*, 139(1):166–183, January 1998.
- [18] A. Bermúdez, L. Hervella-Nieto, A. Prieto, and R. Rodríguez. An optimal perfectly matched layer with unbounded absorbing function for time-harmonic acoustic scattering problems. *Journal of Computational Physics*, 223(2):469–488, May 2007.