

# Large Infrastructure Projects – The Challenging Road to an Optimal Design

*Cristian-Valentin Radulescu*<sup>1</sup> ✉, *Dr. Maria Krumb*<sup>2</sup>  
✉ e-mail: cristian-valentin.radulescu@deutschebahn.com

<sup>1</sup> Deutsche Bahn/ DB InfraGO, ABS 38

<sup>2</sup> BiMa Bauingenieure UG (haftungsbeschränkt) / Deutsche Bahn (extern)

DOI: <https://doi.org/10.14459/icbdb24.20>

**Abstract** As can be seen from several other executed projects, almost all major infrastructure projects in Germany usually extend over many years, from work stage 1, strategic and project definition, to work stage 9, project end. On the railway line 5600 between Munich East and Mühldorf am Inn, the Schwillach embankment in planning approval section 1.2, with the two engineering structures, EÜ Dorfstraße and EÜ Schwillach, is one of the largest earth structures and thus forms the Achilles tendon in German Railway major project “ABS 38” in southern Germany. In this article, we report on the manifold engineering challenges of the design planning of an object, across all stages, how the optimal solution cannot be found directly at the beginning of a project in work stage 2, preliminary planning, but can only be found during the design planning through iterative steps and different influences, dependencies and boundary conditions. Maintaining train operation or building under rolling wheels is particularly important for a single-track railway line, which can make planning and execution even more complicated.

## 1 Introduction ABS38

The development of the current railway line from Munich via Mühldorf to Simbach dates back over 150 years. As part of the major project ABS38 by Deutsche Bahn, the entire double-track expansion of the line from Munich through Mühldorf to Freilassing, at the German-Austrian border, is planned. The branch to the Chemiedreieck Tüßling – Burghausen will remain single-track. To meet current traffic demands, approximately 145 km of the line will be electrified. After the expansion, certain sections will allow for a maximum track speed of up to 200 km/h. Figure 1 provides an overview of the entire project, including the division into the four planning sections, the Daglfinger and Truderinger curves, and the connection to Munich Airport via Erding.

Additionally, the stations and stops will be upgraded to the latest standards, with most being barrier-free to facilitate travel for passengers with mobility impairments. Modern signaling and control technology, as well as measures to increase train frequency, will enable faster train sequences. This results in an overall improved quality and quantity of service for travelers to and from the

region. As part of the track expansion, a total of 166 bridge structures, 23 level crossings, and 19 stations will be renovated or newly constructed. To protect residents from railway noise in the future, active and passive noise protection measures will be implemented at selected locations, in accordance with legal requirements.

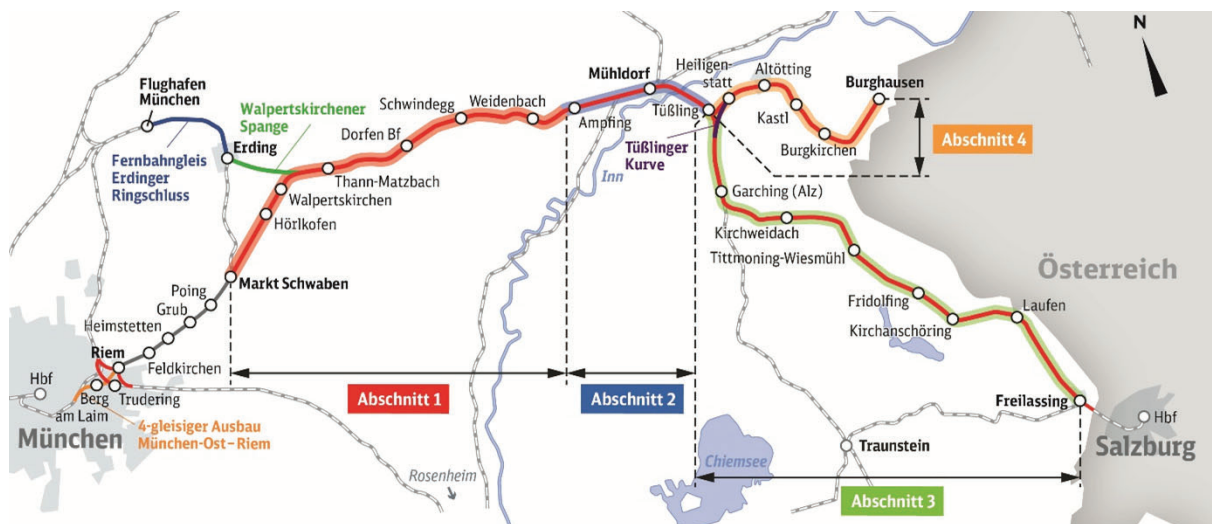

**Figure 1:** Overview Railway Project ABS38 [1]

On the railway line 5600 between Munich East and Mühldorf am Inn, the Schwillach embankment in planning approval section 1.2, with its two engineering structures, EÜ Dorfstraße and EÜ Schwillach, is one of the largest earthworks. Its renovation or necessary expansion for the second track, under stringent operational requirements, constitutes one of the most complex tasks in both planning and execution within planning section 1. In addition to the two engineering structures, an existing gas pipeline must also be considered, as its functionality is essential for the neighboring communities.

## 2 Schwillach embankment

### 2.1 General Information

The largest embankment in planning section 1.2 of the ABS 38 is the so-called “Schwillacher Damm”. It extends from railway kilometer 25.250 to 26.200. Hence, the dam is 950 meters long. The maximum height of the embankment is approximately 14 meters. At this point, the route crosses the small river “Schwillach”. The embankment body is divided into three parts by two bridges. The embankment was constructed for single-track railway operation (see Figure 2 and Figure 3) with a crown width of 8 to 10 meters.

When the railway line was constructed 150 years ago, the existing surface morphology was adjusted in height through excavations and embankments. The removed material of the excavations was directly used to build the embankments. As a result, the “Schwillach Damm” mainly consists of locally occurring soils. For the planned expansion of the railway line from Munich East to Mühldorf,



**Figure 2:** Overview Schwillach dam with two bridges



**Figure 3:** Schwillach dam at km 26,0, South-west view

the embankments need to be improved so that double-track rail traffic with a maximum speed of 200 km/h is possible. This requires not only adapting the two bridges within the embankment to the new requirements and loads, but also widening and improving the embankment so that it can safely bear the increased loads.

## 2.2 History, Geology and Properties

### 2.2.1 Geology

The ABS 38 around the “Schwillacher Damm” is situated in northeast of the “Munich Schotterebene”. This is the area of the northern end of the last glacial end moraines (Rißzeit) and the transition to the Tertiary hilly landscape. In this area, surface-near deposits are predominantly Würmian glacial, aeolian loess clays that cover the last glacial moraine sediments, basin deposits, and advance gravels. The deeper soils consist of the Tertiary Upper Freshwater Molasse, in the form of alternating sequences of fine sands, silts, and clays. As a general stratigraphic sequence, the following classification can be assumed in the embankment area: anthropogenic fill (embankment), natural soils of the Quaternary (loess clays, floodplain sediments, moraine deposits) and natural soils of the Tertiary (alternating sequences of the Upper Freshwater Molasse) [2].

The last glacial moraine soils are predominantly fine-grained soils (clays, silts) with inclusions of coarse and mixed-grained soils (sands, gravels with varying stone content). The Quaternary end moraine deposits lie above the alternating sequences of the Upper Freshwater Molasse (OSM) from the Tertiary. The “Schwillacher Damm” is located in the area of the last glacial moraine landscape. According to the geological map (Figure 4), the Schwillacher Dam runs through Holocene and Pleistocene valley deposits of the river Schwillach up to about km 25.700, with peaty areas and floodplain clays. In this area, predominantly lower terrace gravels from the Würmian glaciation are present in the form of gravels and sands, as well as Pleistocene valley deposits and peaty areas of the stream. The erosion of the river Schwillach has already removed the moraine overlay in the

Schwillach Valley. Therefore, below the subsequently deposited lower terrace gravels, Tertiary soils can already be expected:

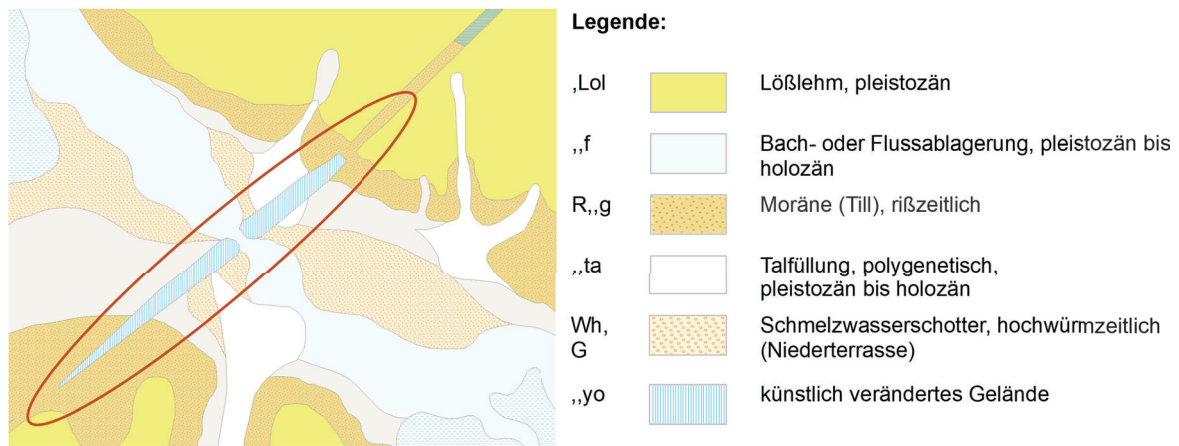

**Figure 4:** Section of the Geological Map with the embankment "Schwillach Damm" [3]

## 2.2.2 Properties of the existing dam

Since 2016/2017, the embankment and its surroundings have been studied in several field and laboratory programs. This resulted in the longitudinal section of the embankment shown in Figure 5 and soil parameters summarized in Table 1. It can be said that material of the embankment primarily consists of relocated moraine clays, with low to intermediate plasticity. The consistency is mainly soft to firm and partly stiff. The actual soil properties of the embankment material suggest that the planned forces of future railway operations cannot be carried without undergoing significant deformation. Therefore, the soils must be improved or replaced.

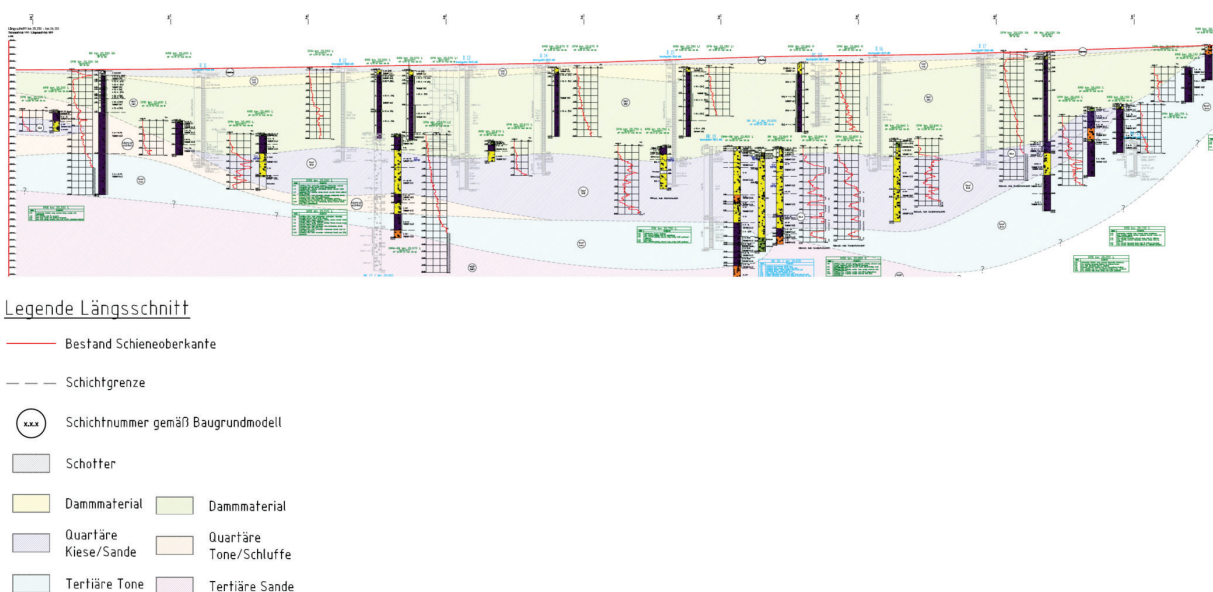

**Figure 5:** Longitudinal section of the dam

In summary, the following measures are currently planned for the embankment Schwillach to enable a double-track railway operation at 200 km/h:

- Attaching material on one side of the embankment to increase the width of the top, necessarily for the second track
- Ensure a consistent depth of the secured load-bearing area of 2.5 m below top of rail according to Ril 836.4101A01
- Improvement of the dam material through replacement, pile slab foundation, FMI method, or mixed in place methods
- Partial re-profiling or support of the slopes of both sites of the embankment

Table 1: Summary of soil properties

soil unit	relative density or consistency	unit weight [kN/m <sup>3</sup> ]		friction angle [°]	cohesion [kN/m <sup>2</sup> ]	constrained modulus [MN/m <sup>2</sup> ]
		$\gamma$	$\gamma'$	$\phi$	$c'$	$E_{s,100}$
dam material I	medium dense to dense	18,5	11,0	35,0	0	20
dam material II	soft to firm / (stiff)	18,5	10,0	29,0	3	3
quaternary sand and gravel	(loose) / medium dense to dense	18,5 – 21,0	9,0 – 12,0	30,5 – 35,0	0	20 - 50
quaternary silt and clay	stiff to hard	19,0 – 21,0	9,0 – 11,0	24,0 – 29,0	6,0 – 20,0	5 – 20
tertiary clay	stiff to hard	19,0 – 21,5	9,0 – 11,5	24,0 – 25,0	13,0 – 35,0	5 – 20
tertiary sand	dense to very dense	19,5 – 21,0	10,0 – 12,0	29,0 – 32,5	0	20 - 40

### 2.3 Preliminary planning - Variant study

To meet the new traffic-related requirements and safely bear the loads, resulted from the increased traffic due to the new number of trains and from the higher travel speeds, various reinforcement measures in the form of so-called deep foundation techniques for the track were examined during the preliminary planning phase.

The definition and requirements for the foundation of railway earth structures are described in Module 4201 of Ril 836. According to this, track bed foundations include all measures beyond the creation of protective layers, including surface-improvement measures on the subgrade, and are aimed at ensuring the load-bearing capacity and usability of the track bed. This involves distinguishing between ground improvement measures and deep foundations.

In the variant study, three possibilities were considered: Milling-mixing injection method (track bed deep foundation, FMI) in conjunction with hydro-cementation (HZV), mixed-in-place, and a combined pile-slab foundation (KPP). Based on cost estimations, without conducting deeper

feasibility studies, it was quickly determined that the KPP option should no longer be pursued. Additionally, the mixed-in-place (MIP) method was examined, which is primarily suitable for sandy and gravelly soils. In the Schwillach embankment, predominantly cohesive soils are present, which are partially underlain by sand/gravel layers. If the MIP columns are extended several meters into the existing sands/gravel, there is a possibility that mixing may draw sand/gravel into the cohesive soil layers, potentially allowing the creation of a suitable MIP column. In areas with exclusively cohesive soils, most of the existing soil would need to be replaced; that is, the MIP column would largely consist of the cement suspension since there would be no mixing with the cohesive material. This would result in significant amounts of drilling spoil, which is why this variant was also not pursued further. Thus, the embankment renovation using the FMI method emerged as the preferred solution.

The deep foundation of the track bed using the FMI method has been successfully employed for years and allows for very effective performance due to the simultaneous execution of multiple work steps. The encountered substrate is loosened using a milling machine. A suspension of water and binding agents is applied at the cutter head of the milling device, which is mixed with the soil material to form a homogeneous mass.

#### 2.4 Short introduction to Deep Soil Mixing Trenching (Fräs-Misch-Injektionsverfahren)

FMI is used to build water-blocking walls in existing dams or dikes for flood protection, or it is used to increase the load-bearing capacities e.g. under a rail track. The main advantage of this technology is a single-phase walling method with an equipment which enables wet mixing of soil and hydraulic binder while cutting trench structures in the ground [4]. The process is illustrated in Figure 6.

FMI applies continuous walls without any soil movements and no sheet piling is necessary. The width of the soil-cement wall is unlimited by building several stripes next to each other.

The milling-mixing-injection method (FMI method) is repeatedly used for ground improvement in the ABS 38 project. It is to be used both as a deep foundation for the carriageway and to improve the subsoil. The Schwillacher Dam is also to be upgraded using the FMI method.

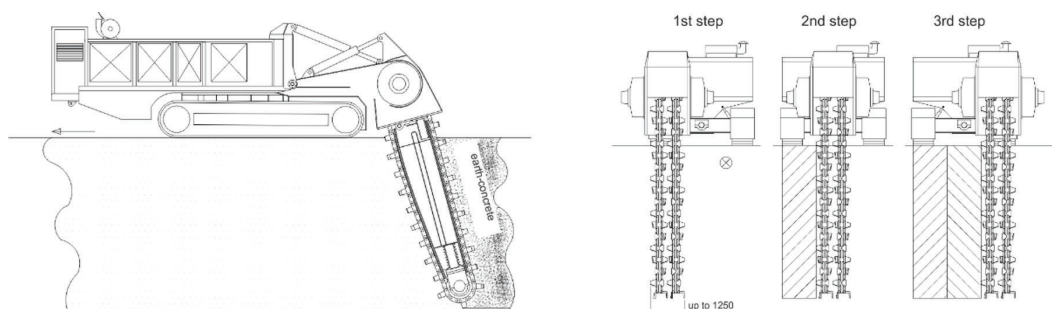

**Figure 6:** Illustration of the FMI method [5]

## 2.5 Current Design

The requirements for track bed foundations are described in Module 4201 of Ril 836. “Railway tracks must be founded to be sufficiently load-bearing and sufficiently serviceable. A railway track is considered sufficiently load-bearing if there is adequate safety against reaching a failure under the intended load from railway traffic.

For tracks on embankments, adequate safety against slope or terrain failure must also be ensured. A railway track is considered sufficiently serviceable if the intended use is not restricted by unacceptable deformations of the subgrade, if the substructure/ground is sufficiently dynamically stable, and if the track allows for low-maintenance use.”

The existing embankment currently does not meet the general requirements of the cited RiL. To carry out the construction measures, it must be ensured that the existing track remains passable and that only short closure periods of a maximum of 3 weeks are available.

The planning therefore includes the following major steps:

- Securing the existing track
- Widening the embankment and constructing the second track
- Using the second track and strengthening the existing track

To assess the fundamental feasibility of strengthening the embankment using the FMI method, FEM (Finite Element Method) calculations were carried out. Figure 7 shows an example of the end condition in a cross-section.

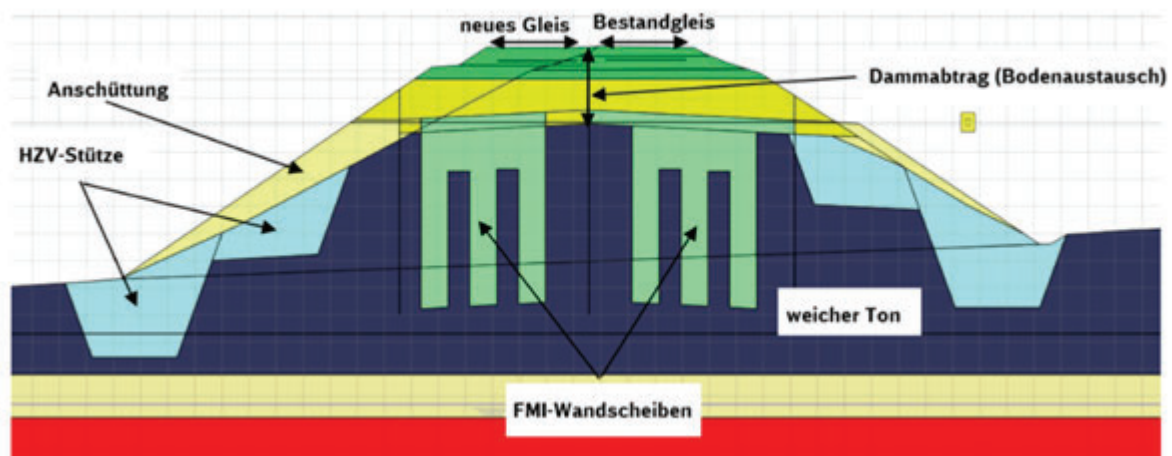

**Figure 7:** Rehabilitated dam with FMI and HZV discs

However, securing the existing track during the construction period poses significant problems. A retaining embankment is planned, consisting of a centrally located retaining wall and side-mounted sheet piles (Figure 8). Since the existing clay has very low stiffness, these constructions are very massive, resulting in long construction times and high costs for intermediate construction states. To prevent the FMI machine from causing slope failure, the slopes must be secured with HZV

bodies before the milling machine is used. These will also provide slope stabilization in the final condition.

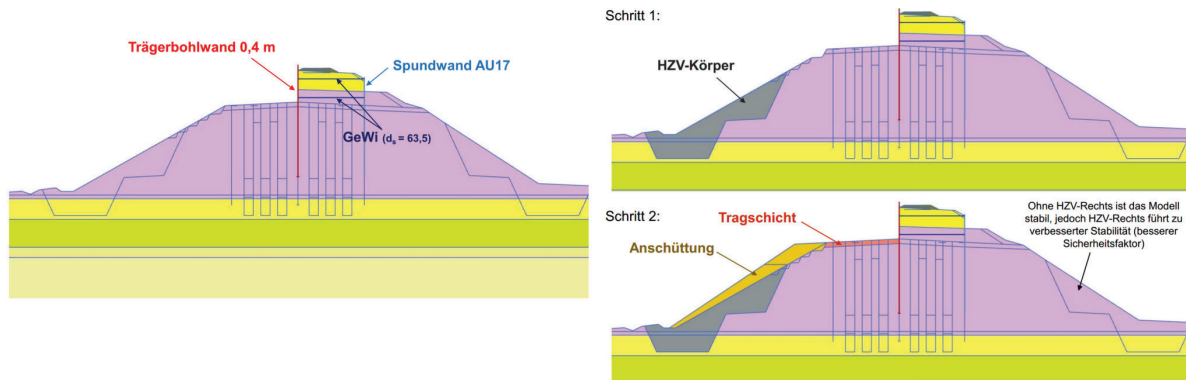

**Figure 8:** Intermediate construction stages of the dam

As the planned construction project, and particularly the accompanying support measures, are very time-consuming and costly, various approaches are currently being examined to optimise the existing planning. The following measures are being examined and implemented. On the one hand, a follow-up investigation with pressure soundings is being carried out to better determine the parameters, and longer closure periods for the existing track are also being considered. These periods will then also allow other approaches to be taken to upgrade or partially rebuild the embankment.

### 3 Dorfstraße Bridge

The existing railway overpass at km 25.561, built in 1871, is an arched structure with a single-track superstructure (Figure 9). The abutments have a flat foundation. After various repair measures were carried out over the years, the bridge on Dorfstraße will also be renewed as part of the new construction route.



**Figure 9:** Existing Dorfstraße bridge

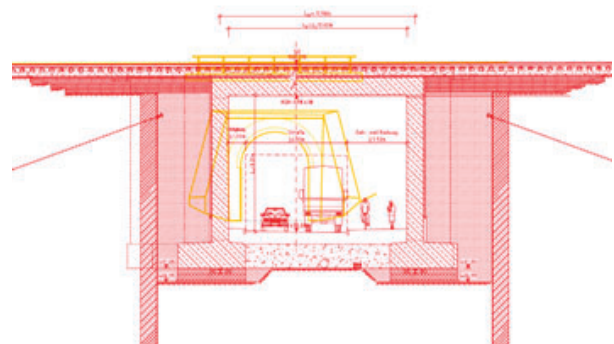

**Figure 10:** Section of Dorfstraße bridge



During the preliminary planning phase, numerous variants were examined. The result of the preliminary planning proposed constructing the structure as a reinforced concrete half-frame with orthogonal wings with cast-in-place concrete. The new construction and expansion of the bridge should enable double-track rail traffic. The demand for widening from the municipality of Ottenhofen in 2018 led to further variant studies. The construction variants compared were a half-frame made of reinforced concrete and a single-span girder as a WiB (rolled beams in concrete) superstructure. Additionally, symmetrical and asymmetrical widening of the structure relative to the existing bridge was compared based on these construction variants. The decision was made in favor of the frame with asymmetrical widening. This represents the most economical option and offers advantages in terms of maintenance and durability of the structure. The asymmetrical widening and the resolution of the clothoids allowed for favorable traffic routing (improvement of sightlines). The adjustment of the crossing angle and road alignment was coordinated with the municipality. For the frame structure, a non-buried solution was chosen, which is justified by both lower dead loads and the elimination of a construction joint between the tracks. Technologically, a combination of using temporary bridges and sliding was selected. This was chosen because it allows the road traffic to be largely maintained, providing advantages for the overall diversion concept in section 1.2. Additionally, the chosen construction method minimizes the necessary work during the closure period for the insertion, which is beneficial for construction traffic, logistics, and coordination with parallel work on the Schwillach embankment. This reduces interfaces and dependencies. The current design (Figure 10) features a clear width of 10.50 meters, which includes space for the road as well as a pedestrian and bicycle path, and a narrow emergency walkway. In the further design process, the construction method was optimized. The planned temporary bridge would have not only incurred additional rental costs but also required an expensive foundation. Due to the approximately 9.0-meter high embankment with poorly load-bearing soils, a back-anchored bored pile foundation was necessary, which would have conflicted with the embankment renovation and the corresponding track bed foundation. After discussions with the municipality, it was agreed to a longer road closure, allowing for the complete construction of the structure in the side position with subsequent cross-insertion. The demolition work, insertion of the new bridge, and construction of the superstructure will occur during a 5-day closure without the need for a temporary bridge.

## 4 Schwillach Bridge

The railway bridge at km 25.817 over the Schwillach was originally constructed in 1871 according to the bridge book, featuring two truss girder superstructures on a central pier and two abutments. The abutments and pier are made of natural stone, while the wings were constructed from tuff stone blocks. Both spans have a clear width of approximately 27.60 meters. In 1935, the truss superstructure with the lower deck over the Tiroler Axis was added, and the girders were reinforced and partially renewed and installed over the Schwillach. At that time, the bearings of the abutments and the pier were supplemented with reinforced concrete. In 1960, the 60-year-old truss superstructures were replaced with a new superstructure, which is still in place today. The currently existing superstructure is a two-span steel composite continuous beam. The abutments and central

pier are shallow founded. As part of the major ABS38 project, a new replacement building is also planned to replace the existing bridge Schwillach.

In the preliminary planning for the new design, various variants were examined, ranging from arch structures in solid construction to fish-belly girders made of steel. Ultimately, the preferred variant selected was a design with a resolved truss in steel composite. The construction of the arch structure near to a drinking water protection area and the stringent requirements from railway operations prompted a new solution.

As an optimised design, as shown in Figure 11, a three-span bridge in steel composite construction was proposed in 2018. The superstructure will be a steel composite construction with fully welded beams, prefabricated concrete upper flange, and in-situ concrete overlay. The welded beams will be equipped with a 15 cm thick concrete flange at the upper flange in the factory. After the concrete has set, the prefabricated beams are transported to the construction site and laid on temporary abutments. Subsequently, in-situ concrete will be applied to the concrete flange, which serves as formwork. The concrete flange and the in-situ concrete overlay will be connected by head bolts.

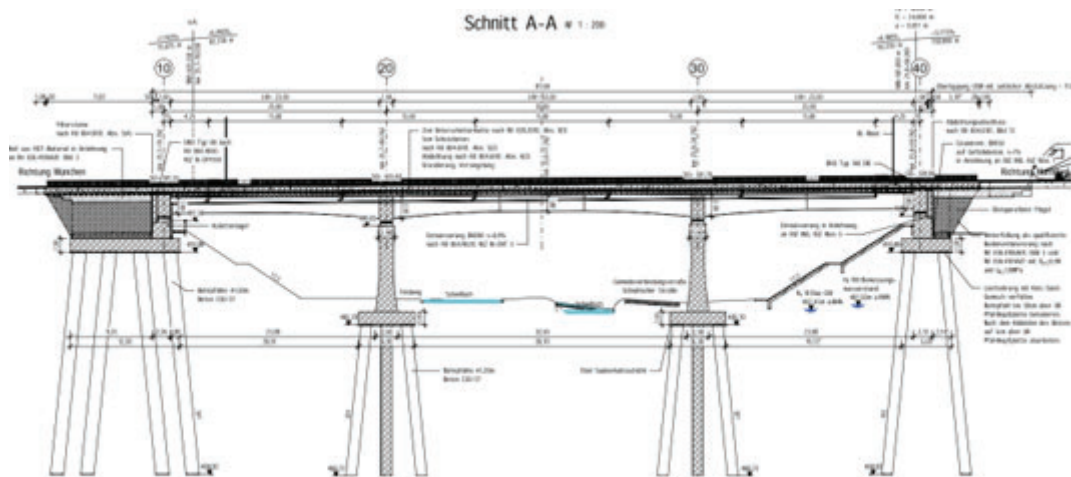

**Figure 11:** Section of Schwillach bridge design 2020

With its three spans of 25m-35m-25m and a total length of 87.50 meters, the Schwillach railway bridge was for a long time the largest bridge in the western planning section of ABS 38. In 2019, a significant operational change by Deutsche Bahn raised the train speed on the newly renovated route from 160 km/h to 200 km/h. This led to the need for both a wider cross-section and a more substantial foundation, requiring bored piles of up to 24 meters.

Due to these new conditions and their implications, the existing design at that time was no longer economically feasible. In the subsequent planning process, the structure was re-evaluated, leading to the bridge design shown in Figure 12, which was developed in 2022. The new design features a single-span composite cross-section on shallow-founded abutments with a span of approximately 36 meters. The superstructure will be a steel composite plate girder consisting of four steel beams and an upper reinforced concrete slab. The steel beams will be designed as welded beams, and the concrete slab will be cast in place.

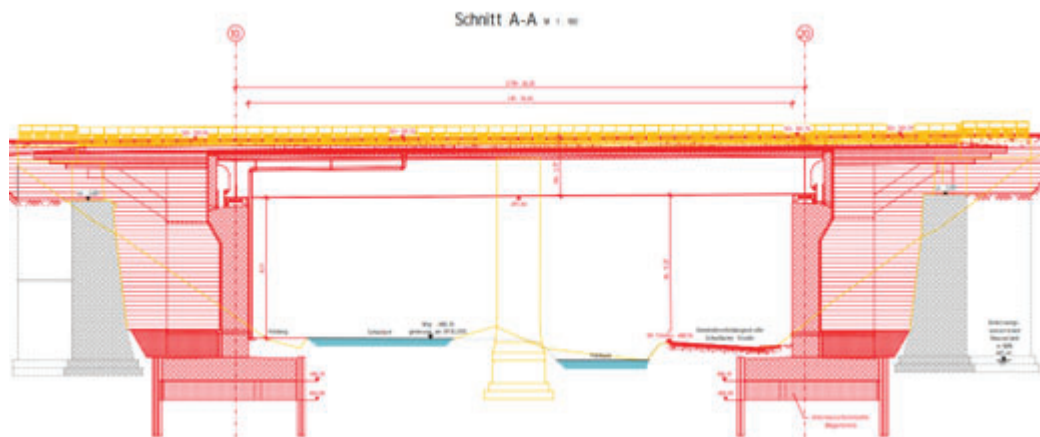

**Figure 12:** Section of Schwillach bridge design 2022

## 5 Summary

It is well known that the planning and design of major infrastructure projects involves a complex, multi-phased process aimed at ensuring that the project meets its objectives in an efficient manner. Each stage involves detailed work and coordination among various professionals, including engineers, planners, and project managers. Effective communication and stakeholder involvement are crucial throughout the process to ensure the project's success.

Over the course of time, a major project undergoes many changes for various reasons. Changes during the planning stage involve iterative engagement with stakeholders to incorporate their feedback and adjust plans accordingly. Effective time management ensures that the planning process remains on schedule, balancing stakeholder input with project timelines. Both areas require careful coordination and flexibility to accommodate evolving needs and unforeseen issues.

The design and planning of single-track railway lines, present numerous challenges that require iterative solutions. Initially, during the preliminary planning stage, it is impossible to identify the optimal solution due to incomplete information and evolving constraints. The iterative design process becomes essential as it allows for adjustments and refinements based on new data, stakeholder feedback, and operational requirements. In the case of single-track railways, maintaining train operations while executing construction adds an extra layer of complexity, requiring careful planning and dynamic adjustments.

Through all this presented case studies, it is evident that ongoing iterations and adaptations are crucial for arriving at a feasible and effective design solution. Understanding and embracing these iterative steps help manage dependencies, constraints, and evolving conditions, ultimately leading to successful project outcomes.

## 6 References

- [1] <https://www.abs38.de/home.html>

- [2] Stoll, R.D.: Geotechnischer Bericht 1.13, Los 1 km 20,300 bis 27,700 Erdbauwerke
- [3] <https://atlas.bayern.de>
- [4] EBA: 21.43 Ibzb (010/07) - Anwendung des Fräs-Misch-Injektions-Verfahrens (FMI-Verfahren) (2007)
- [5] <https://www.allcons.de/deep-soil-mixing-trenchers-dsm-fmi/>