

Adaptive Scan Planning for 4D-BIM-based Construction Progress Monitoring

Florian Noichl, Sebastian Esser and Jonas Schlenger

Chair of Computational Modeling and Simulation,
Technical University of Munich, Arcisstr. 21, Munich, Germany

E-mail(s): florian.noichl@tum.de, sebastian.esser@tum.de, jonas.schlenger@tum.de

Abstract: Construction projects often struggle with cost overruns and time delays, prompting the use of continuous progress monitoring. After initiating a project, crucial processes can be monitored geometrically using conventional methods, cameras, surveying equipment, or advanced technology like laser scanning and high-resolution cameras. Robotic platforms, such as UAVs, UGVs, and quadruped robots, can carry sensors and equipment to perform these surveying tasks to automate processes further. Before any data collection can be performed, the scanning process must be thoroughly planned based on the requirements for the information to be collected, the anticipated conditions at the job site, and the hardware specifications of the equipment being used. Recent advances in the field of incremental model updates provide a promising technique for identifying critical perspectives by analyzing BIM models that reflect specific construction milestones. In this paper, we present an approach to automatically generate suitable scan strategies focused on such construction milestones, originating from a 4D BIM model. Our proposed solution can consider the dynamically changing environment of a construction site while ensuring globally suitable optimized equipment placement. The incremental nature of this approach promises detailed insights into actual construction progress while limiting the effort required at each construction stage for efficient and high-quality coverage.

Keywords: progress monitoring, as-built verification, point cloud, laser scan, automation, scan planning, viewpoint planning



Erschienen in Tagungsband 34. Forum Bauinformatik 2023, Bochum, Deutschland, DOI: 10.13154/294-10087

© 2023 Das Copyright für diesen Beitrag liegt bei den Autoren. Verwendung erlaubt unter Creative Commons Lizenz Namensnennung 4.0 International.

1 Introduction

In the contemporary landscape of the construction industry, the integration of digital technologies and tools holds vast potential for optimizing diverse facets of the construction process, spanning from initial planning and design to the meticulous execution and effective management of projects. While the

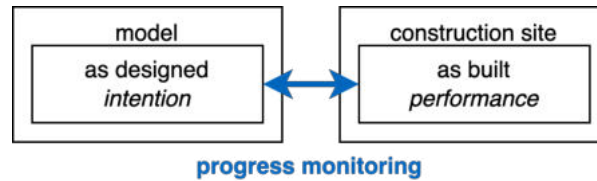

Figure 1: Conceptual embedding of progress monitoring: target-performance comparison between design and construction.

majority of such developments so far are aimed at the planning phase, the construction phase can largely benefit from advanced technologies as well. Construction projects are usually complex and long, taking several months or even years to complete. For the project planning but also its execution, it is necessary to break down the project into smaller pieces. In the spatial context, a building is broken down into individual construction sections or phases. Technical factors and economic aspects influence this subdivision. The bigger the sections are, the more formwork, personnel, and equipment are needed simultaneously. Finding the optimal amount of resources with the corresponding section sizes that minimize the overall project costs is highly challenging. While the just mentioned subdivision referred to breaking down components of the same type into smaller sections, construction processes can also be broken down into individual construction steps. Usually, every step in the process is executed by a different worker crew, resulting in the crews going through the sections of a building in a fixed sequence [1]. It is required to properly understand the overall work breakdown structure to adapt the scan planning accordingly.

The reality of large construction projects on site is complex and changing on a daily basis. Keeping track of actual progress made, equipment, personnel, and material helps to keep a project on track and make the right decisions at the right moment. Methods that can help this are generally referred to with the term progress monitoring, keeping track of relevant data and processes on-site [2], as depicted conceptually in Figure 1.

To enable these methods, suitable data needs to be made available for analysis. In the context of shell construction, highly precise data on the current geometric state of the project can be acquired using LiDAR (Light Detection and Ranging) sensors; the highest precision can be achieved using TLS systems (Terrestrial Laser Scanning), which are stationary, expert-operated systems. This acquisition needs to be planned and conducted thoroughly. Based on the requirements provided by data processing and the actual progress made (cf. Figure 2), either of them needs to be repeated. Thus, scan planning becomes an iterative process that should ideally be automated to reduce cost and ensure quality. Further, once robotics should be deployed in the future to execute data acquisition missions, the step of planning requires automation to fully automate the data acquisition process.

Until now, methods for scan planning have shown several limitations when it comes to applicability in the construction context. With this work, we provide an approach that aims to work directly on scenes extracted from the 4D information encapsulated inside a BIM model to adaptively propose an optimal scan plan for each construction section.

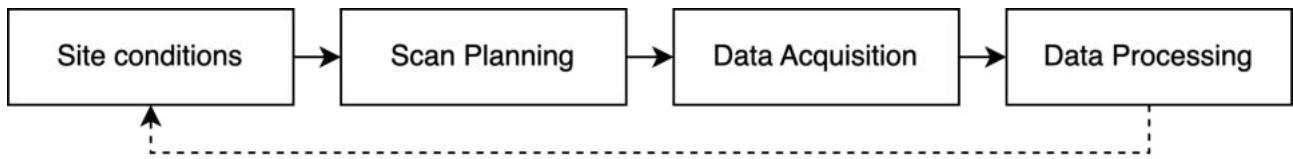

Figure 2: Iterative process steps for data acquisition on the construction site.

2 Related Works

Digital models help individual stakeholders and project-wide collaboration in all kinds of construction projects. According to the method of Building Information Modeling (BIM), these models shall be as rich in geometric and semantic information as needed; with regards to the construction schedule, time information can be included in a so-called 4D BIM model by linking individual components of the BIM model with their corresponding processes in the construction schedule [3]. In the first place, a schedule is created to orchestrate and coordinate construction activities. During and after construction, schedule information can be used to verify activities and milestones, and to structure and guide all monitoring activities [4].

Especially during shell construction, LiDAR sensors, and especially TLS are chosen as they offer high precision and acquisition speed [5]; many national and international quality standards have deviation tolerance in the range of a few mm so the high accuracy of TLS is needed [2]. Often scans are done once at the very end of the construction phase to generate an as-built model. While limiting effort for planning, acquisition, and data processing to a single time, there is also great value in capturing the progress in parallel with the construction process, as this helps to iteratively compare the planned with the actual execution to identify deviations as soon as possible and be able to react accordingly. To do so, one could perform scans on an e.g. weekly basis, but there are specific points in time when the scans can provide the most value, which is not necessarily in constant time intervals.

Recent research includes reviews on the level of automation reached in the monitoring of progress, showing that many manual steps are still required in the monitoring process, starting with data acquisition to the presentation of the extracted knowledge to the end user [6]. It shows how important automation is to make progress monitoring more affordable by requiring less and less human intervention. Quality control also plays an important role in progress monitoring because one not only needs binary information if a part was built but also whether this part complies with the specified quality requirements; only then can it be considered to be finished.

Planning for such acquisition missions is classically called viewpoint planning and in the domain referred to as scan planning [7]. Approaches automating this process are conventionally performed on the basis of 2D plans or laser scan simulation [8], [9]. Recent approaches aim to work directly with 3D surfaces in the form of 3D meshes [10]. In the context of construction monitoring, [11] aims to optimize the placement of camera equipment for safety monitoring. What is missing in the existing body of literature is a method that is able to work directly with incremental model changes to enable automated, continuous progress monitoring.

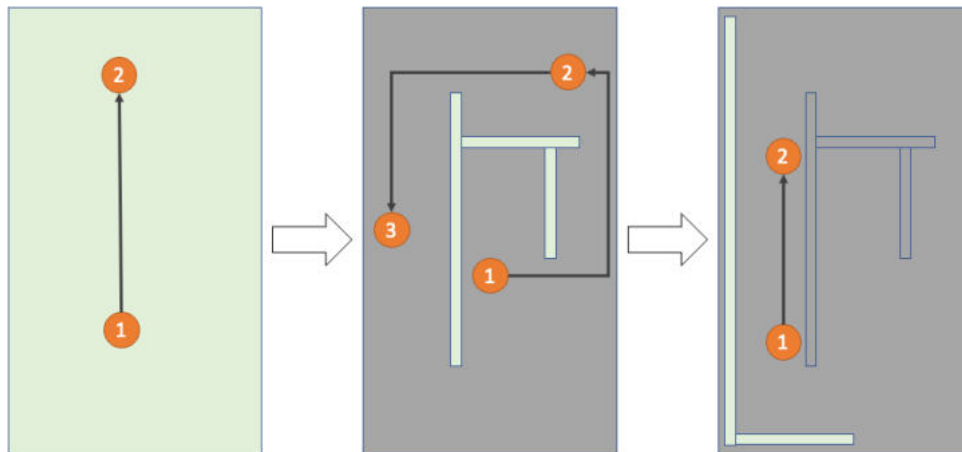

Figure 3: Illustrative example of a construction site that is split into three phases. The orange dots indicate optimal locations to capture each phase with a terrestrial laser scanner.

3 Method

Our adaptive scan planning approach for 4D-BIM-based construction progress monitoring aims to provide the best acquisition strategy per construction stage, as shown in Figure 3. This approach is based on the method presented in [10] and can be summarized as follows:

- input: as-designed geometry (patch p representation of the known delta) for each phase in question: $p_{\Delta,t}$ for $t \in t_0, t_1, t_2, \dots, t_n$, where $p_{\Delta,t}$ describes the set of triangular faces representing the geometric difference between $t = i$ and $t = i - 1$, i.e. the planned progress for phase/step t
- explicitly: for every investigated time step i , scan planning is conducted to cover patch $p_{\Delta,i}$, while the accumulated construction progress up to this point is considered, yet not necessarily covered: $\bigcup_{j=0}^{i-1} p_{\Delta,t_j}$

Based on these accumulated patches as a scene, we perform scan planning using the method presented in [10], briefly summarized as follows:

1. generate suitable viewpoint candidates
2. assess the viewpoint candidates in terms of scene surface coverage and overlap
3. select viewpoints such that pre-defined quality criteria are fulfilled.

The viewpoint candidate selection is performed based on the data resulting from the viewpoint candidate assessment step (3.) using a greedy algorithm [12], which can be described in brief as depicted in Algorithm 1. After viewpoint selection is complete, the shortest path to visit them sequentially is determined by approximating a solution for the traveling salesman problem on a graph representation of the viewpoint candidates. For a detailed introduction of the variables and formulas used, the reader is referred to [10].

Algorithm 1 Greedy algorithm for viewpoint selection, adapted from [10]

```

VPselect := ∅ // initiate empty solution
while ∑j Ci=VPselect,j < cmin // while coverage criterion is not met
do
  calculate Si = ∑j Ci,j // calculate score per candidate
  VPselect.append(maxS VPi) // append best candidate to solution
  Ci,j = 0 ∀ Ci=VPselect,j ≠ 0 // delete covered faces from C
end

```

As highlighted in the previous paragraphs, many state-of-the-art authoring applications used in BIM projects can reflect different construction phases in their systems. We adopt this feature and assume an enriched BIM model that contains the definition of different construction phases. The different phases are then used to filter the BIM model to realize an incremental capture of newly constructed components.

4 Experiment and results

To demonstrate the methodology with a real-world example, we perform two experiments using a model of the shell construction of an industrial building; one in the conventional setting on a full model geometry and one using our adaptive way on three consecutive patches representing respective construction phases. The choice of phase limits is arbitrary and meant for an exemplary explanation only. All experiments were carried out using our own implementation, specifically using the open-source libraries NetworkX¹ and Open3D²; the model was created using Autodesk Revit³.

4.1 Baseline: full geometry

The first experiment is conducted on the full 3D model of the industrial building, as depicted in Figure 4(a). The results are depicted in Figure 4(b) and Table 1. It can be seen that the approach results in a scan plan that requires 12 viewpoints throughout the facility to meet the required coverage of 98% of the reachable surfaces. The top of the inner structure is used to achieve this; all viewpoints can be reached using the shown path.

4.2 Application: adaptive scan planning

The same model is processed in the construction phases encoded in its 4D model, and the respective surface patches are shown in Figures 5 (a-c). Adaptive scan planning leads to varying results for each construction phase, depicted in Figures 5 (d-f); while the first two phases are limited to the ground floor and newly constructed slab, the third phase containing the inner structure can leverage the top of

¹<https://networkx.org>

²<https://open3d.org>

³<https://autodesk.com/products/revit>

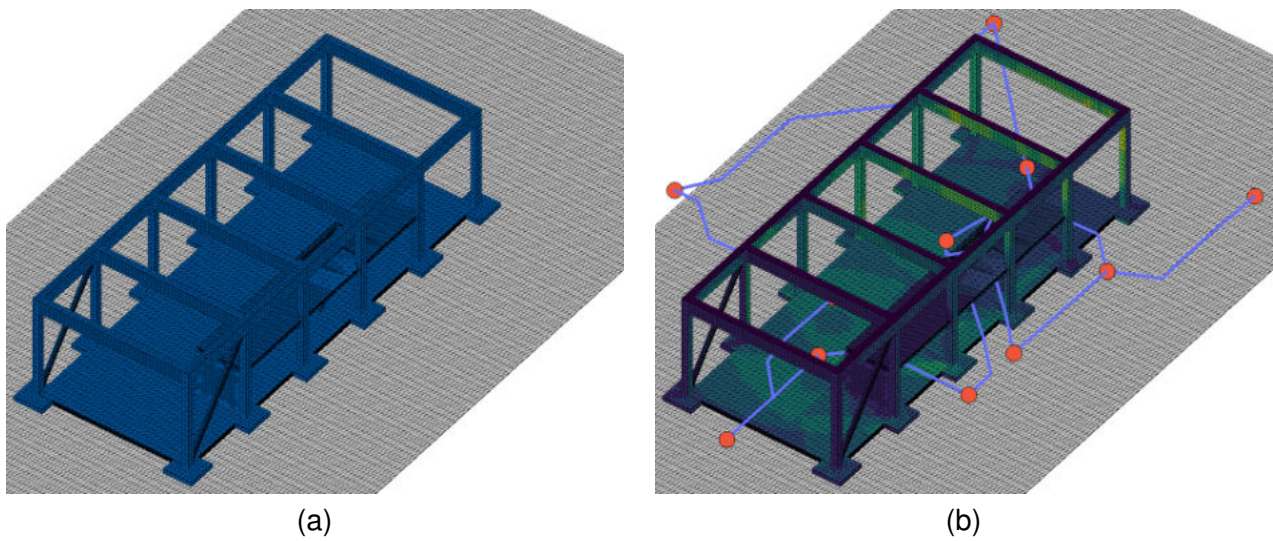

Figure 4: Experiment results for the baseline experiment on the full geometry of the industrial building: (a) full geometry (blue) and idealistic floor plane (grey); (b) scan planning results, model surface colored according to the frequency of coverage (dark blue to yellow with increasing frequency), selected viewpoints (orange) and shortest path to visit them in a closed loop (violet).

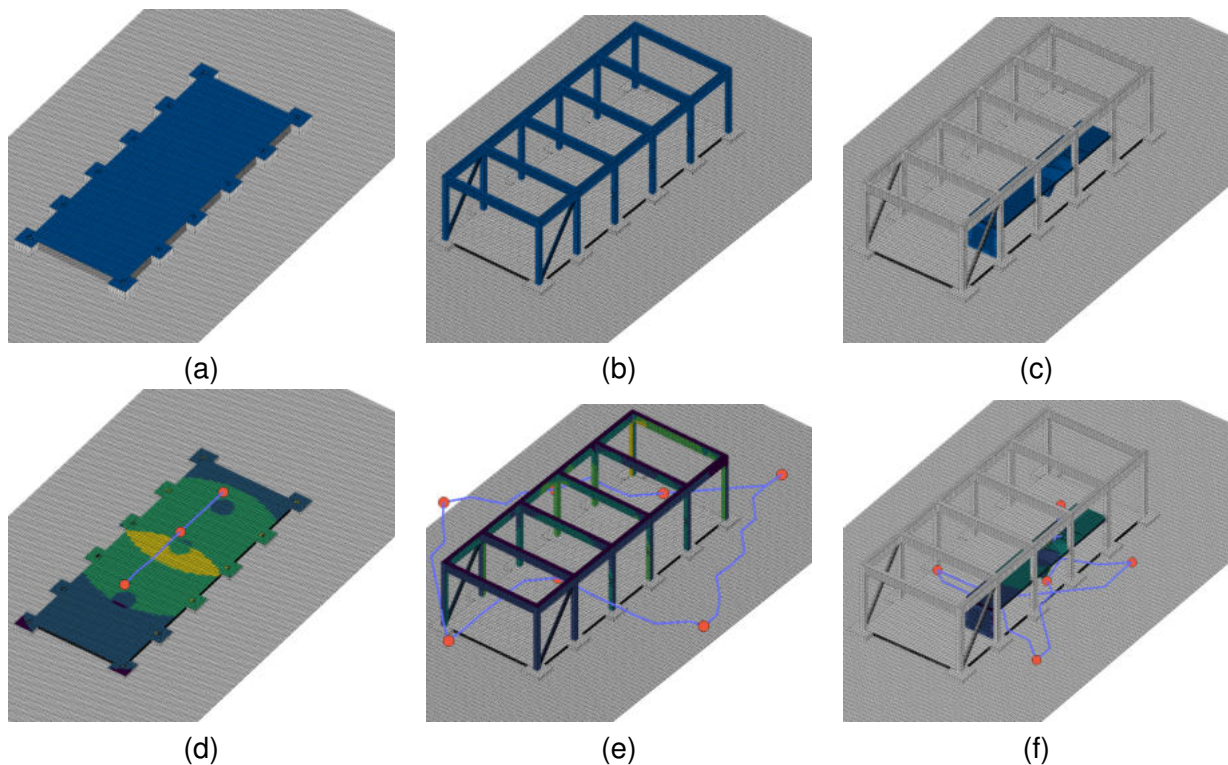

Figure 5: Experiment results for the adaptive scan planning on the industrial building: First row (a-c) construction stages with surface patches depicting the changes in geometry highlighted (blue), second row (d-f) result of stage-wise scan planning, delta patch surface colored according to the frequency of coverage (dark blue to yellow with increasing frequency), selected viewpoints (orange) and shortest path to visit them in a closed loop (violet).

Table 1: Experiment results: baseline and adaptive scan planning for the industrial building model, the same parameters are used in both experiments

scenario	part	required viewpoints
baseline	full model	12
adaptive	slab	3
	skeleton	6
	interior	5
	sum	14

this structure, just like the baseline model. In the previous phases, this structure has not been built and is not yet available.

4.3 Comparison

Table 1 contains the resulting numbers in comparison. While the total number of viewpoints for the adaptive scan planning approach with individual processing of each construction phase leads to a greater number of total required viewpoints, it allows for more fine granular updates during construction, with less effort per acquisition mission. Further, there are areas in the constructed surfaces that are occluded once the full shell is constructed; those can only be captured using the adaptive scan planning approach: If the laser scan is only performed once the construction is complete, this information is lost.

5 Outlook

The limited experiment presented in this paper shows that adaptive scan planning can support construction progress monitoring, contributing to more automation in the process. While the cumulative effort likely exceeds the effort of one-shot acquisition, each mission becomes less extensive and time-consuming, while the information lost in joints between construction phases and areas later inaccessible is limited to a minimum.

We assume that the objects that are included in an incremental update between two construction phases have actually been constructed in reality. This is a limitation in two respects: First, the 4D information needs to be included in the model in the first place. Second, there may be a deviation between the planned execution and the actual progress on site. Additional equipment for continuous monitoring can significantly improve this issue in identifying a suitable date to perform the scan using the optimized scan plan.

Sensible future work on this topic includes the improvement of selection algorithms and the robust applicability of scan planning methods on previously acquired data as input instead of as-designed models. An additional interesting aspect is an investigation on when to best perform data acquisition rather than simply taking over existing construction phases.

References

- [1] C. Hofstadler, *Bauablaufplanung und Logistik im Baubetrieb*, 1st ed. Springer Berlin, Heidelberg, 2007, ISBN: 978-3-540-34320-2. DOI: <https://doi.org/10.1007/978-3-540-34321-9>.
- [2] M. Rezoug, G. Picinbono, T. Delval, et al., “D3.1 - Requirements Specification for Digital Twin-Supported Progress Monitoring and Quality Control WP3-PROGRESS MONITORING & QUALITY CONTROL FOR VOLUMETRIC BUILDING”, Tech. Rep., 2020.
- [3] A. Borrmann, M. König, C. Koch, and J. Beetz, *Building Information Modeling : Why ? What ? How ?* Springer, 2018. DOI: 10.1007/978-3-319-92862-3.
- [4] K. K. Han and M. Golparvar-Fard, “Automated Monitoring of Operation-Level Construction Progress Using 4D BIM and Daily Site Photologs”, in *Construction Research Congress*, 2014, pp. 1033–1042. DOI: <https://doi.org/10.1061/9780784413517.106>.
- [5] F. Bosché, M. Ahmed, Y. Turkan, C. T. Haas, and R. Haas, “The value of integrating Scan-to-BIM and Scan-vs-BIM techniques for construction monitoring using laser scanning and BIM: The case of cylindrical MEP components”, *Automation in Construction*, vol. 49, pp. 201–213, Jan. 2015, ISSN: 09265805. DOI: 10.1016/j.autcon.2014.05.014. [Online]. Available: <http://dx.doi.org/10.1016/j.autcon.2014.05.014>.
- [6] M. Sami Ur Rehman, M. T. Shafiq, and F. Ullah, *Automated Computer Vision-Based Construction Progress Monitoring: A Systematic Review*, Jul. 2022. DOI: 10.3390/buildings12071037.
- [7] A. Aryan, F. Bosché, and P. Tang, “Planning for terrestrial laser scanning in construction: A review”, *Automation in Construction*, vol. 125, no. December 2020, 2021, ISSN: 09265805. DOI: 10.1016/j.autcon.2021.103551.
- [8] F. Jia and D. D. Lichti, “A Comparison of Simulated Annealing, Genetic Algorithm and Particle Swarm Optimization in Optimal First-Order Design of Indoor TLS Networks”, *ISPRS Annals of the Photogrammetry, Remote Sensing and Spatial Information Sciences*, vol. 4, no. 2W4, pp. 75–82, 2017, ISSN: 21949050. DOI: 10.5194/isprs-annals-IV-2-W4-75-2017.
- [9] G. Rougeron, J. L. Garrec, and C. Andriot, “Optimal positioning of terrestrial LiDAR scanner stations in complex 3D environments with a multiobjective optimization method based on GPU simulations”, *ISPRS Journal of Photogrammetry and Remote Sensing*, vol. 193, no. February, pp. 60–76, 2022, ISSN: 0924-2716. DOI: 10.1016/j.isprsjprs.2022.08.023.
- [10] F. Noichl and A. Borrmann, “Towards Multicriterial Scan Planning in Complex 3D Environments”, in *ICCCBE. Proc. of International Conference on Computing in Civil and Building Engineering*, Oct. 2022.
- [11] S. V.-T. Tran, T. L. Nguyen, H.-L. Chi, D. Lee, and C. Park, “Generative planning for construction safety surveillance camera installation in 4D BIM environment”, *Automation in Construction*, vol. 134, no. December 2021, 2022, ISSN: 09265805. DOI: 10.1016/j.autcon.2021.104103.
- [12] F. Jia and D. D. Lichti, “A Practical Algorithm for the Viewpoint Planning of Terrestrial Laser Scanners”, *Geomatics*, pp. 181–196, 2022.