

The change in outdoor thermal comfort due to different densification scenarios (horizontal/vertical). The effect of greening scenarios as a mitigation measure in case of densification.

Wissenschaftliche Arbeit zur Erlangung des Grades
M.Sc. Bauingenieurwesen
an der Fakultät für Architektur/Ingenieur fakultät Bau, Geo Umwelt der
Technischen Universität München.

Betreut von Prof. Dr.-Ing. Werner Lang, M.Sc. Farzan Banihashemi,
M.Eng. Roland Reitberger
Lehrstuhl für Energieeffizientes und nachhaltiges Planen und Bauen

Eingereicht von Egi Kalaj

Eingereicht am Munich, 25.08.2022

Vereinbarung

zwischen

der Technischen Universität München, vertreten durch ihren Präsidenten,
Arcisstraße 21, 80290 München

hier handelnd der Lehrstuhl für Energieeffizientes und Nachhaltiges Planen und Bauen
(Univ.-Prof. Dr.-Ing. W. Lang), Arcisstr. 21, 80333 München

– nachfolgend TUM –

und

Frau/Herrn

(Anschrift)

– nachfolgend Autorin/Autor –

Die Autorin / der Autor wünscht, dass die von ihr/ihm an der TUM erstellte Masterarbeit mit dem Titel

.....

auf mediaTUM und der Webseite des Lehrstuhls für Energieeffizientes und Nachhaltiges Planen und Bauen mit dem Namen der/des Verfasserin/s, dem Titel der Arbeit, den Betreuer/innen und dem Erscheinungsjahr genannt werden darf.

in Bibliotheken der TUM, einschließlich mediaTUM und die Präsenzbibliothek des Lehrstuhls für Energieeffizientes und Nachhaltiges Planen und Bauen, Studenten und Besuchern zugänglich gemacht und veröffentlicht werden darf. Dies schließt auch Inhalte von Abschlusspräsentationen ein.

mit einem Sperrvermerk versehen und nicht an Dritte weitergegeben wird.

(Zutreffendes bitte ankreuzen)

Zu diesem Zweck überträgt die Autorin / der Autor der TUM zeitlich und örtlich unbeschränkt das nichtausschließliche Nutzungs- und Veröffentlichungsrecht an der Masterarbeit.

Die Autorin / der Autor versichert, dass sie/er alleinige(r) Inhaber(in) aller Rechte an der Masterarbeit ist und der weltweiten Veröffentlichung keine Rechte Dritter entgegenstehen, bspw. an Abbildungen, beschränkende Absprachen mit Verlagen, Arbeitgebern oder Unterstützern der Masterarbeit. Die Autorin / der Autor stellt die TUM und deren Beschäftigte insofern von Ansprüchen und Forderungen Dritter sowie den damit verbundenen Kosten frei.

Eine elektronische Fassung der Masterarbeit als pdf-Datei hat die Autorin / der Autor dieser Vereinbarung beigelegt. Die TUM ist berechtigt, ggf. notwendig werdende Konvertierungen der Datei in andere Formate vorzunehmen.

Vergütungen werden nicht gewährt.

Eine Verpflichtung der TUM zur Veröffentlichung für eine bestimmte Dauer besteht nicht.

Die Autorin / der Autor hat jederzeit das Recht, die mit dieser Vereinbarung eingeräumten Rechte schriftlich zu widerrufen. Die TUM wird die Veröffentlichung nach dem Widerruf in einer angemessenen Frist und auf etwaige Kosten der Autorin / des Autors rückgängig machen, soweit rechtlich und tatsächlich möglich und zumutbar.

Die TUM haftet nur für vorsätzlich oder grob fahrlässig verursachte Schäden. Im Falle grober Fahrlässigkeit ist die Haftung auf den vorhersehbaren Schaden begrenzt; für mittelbare Schäden, Folgeschäden sowie unbefugte nachträgliche Veränderungen der veröffentlichten Masterarbeit ist die Haftung bei grober Fahrlässigkeit ausgeschlossen.

Die vorstehenden Haftungsbeschränkungen gelten nicht für Verletzungen des Lebens, des Körpers oder der Gesundheit.

Meinungsverschiedenheiten im Zusammenhang mit dieser Vereinbarung bemühen sich die TUM und die Autorin / der Autor einvernehmlich zu klären. Auf diese Vereinbarung findet deutsches Recht unter Ausschluss kollisionsrechtlicher Regelungen Anwendung. Ausschließlicher Gerichtsstand ist München.

München, den _____, den _____

.....

(TUM)

.....

(Autorin/Autor)

Erklärung

Ich versichere hiermit, dass ich die von mir eingereichte Abschlussarbeit selbstständig verfasst und keine anderen als die angegebenen Quellen und Hilfsmittel benutzt habe.

Ort, Datum, Unterschrift

Table of Content

Vereinbarung	I
Erklärung	IV
Table of Content	1
Abstract	3
Kurzfassung	4
Acknowledgments	5
List of Abbreviations	6
Glossary	7
1. Introduction.....	8
2. State of the art.....	11
2.1. Urban heat island effect.....	11
2.2. Comparison of types of densifications	12
2.2.1. Densification by roof stacking	13
2.2.2. Densification by infill strategies.....	14
2.3. Densification effect on microclimate	14
2.3.1. Importance of the albedo of materials and their effect in micro-climate. 16	
2.3.2. Greenery as a mode of reducing the adverse effects of densification on microclimate	17
2.4. Urban Weather Generator and Vertical City Weather Generator	18
2.5. Comparison of UTCI and PET for calculation of outdoor comfort.....	20
3. Methodology.....	22
3.1. Overview of research methodology	22
3.2. Introduction to the software used for the parametric flow	24
3.3. Parametric flow for calculation of UTCI.....	26
3.3.1. Creation of buildings for the run of the UWG	26
3.3.2. Running the UWG	27
3.3.3. Calculation of Outdoor Surface Temperatures.....	29
3.3.4. Addition of trees in the urban area with PANDO	32
3.3.5. Calculation of UTCI for a specific point and all the urban area.....	33
3.3.6. Visualization workflow for the UTCI map and climate parameters.....	35
4. Case Study.....	37
4.1. Study area.....	37
4.1.1. The climate in the study area.....	39
4.2. Scenarios considered for the case study	40
4.3. The input of buildings characteristics for studied buildings.....	43

4.3.1.	Building height	43
4.3.2.	Building's glazing ratio and SHGC values.....	45
4.3.3.	Building age.....	47
4.3.4.	Building's construction set	47
4.3.5.	Building's programs	48
4.3.6.	Albedo and thickness of terrain.....	48
4.3.7.	The albedo of walls and roof for each building	49
4.4.	Calculation of parameters for the weather station area	51
4.5.	Anthropogenic heat for the urban area in Kempten.....	54
4.6.	Grass coverage and addition of tree parameters for today's scenario	55
4.7.	Grass coverage and tree addition for Scenario 5B.....	56
5.	Results and discussion	59
5.1.	The decision of the representative hour for further calculations	59
5.2.	The air temperature difference between the weather station and today's scenario	60
5.3.	Change of air temperature from today's scenario to the different densification and vegetation scenarios.....	63
5.4.	The difference in MRT between scenarios	64
5.4.1.	Heat maps of MRT for different scenarios.....	65
5.5.	The difference in UTCI between scenarios (heat maps).....	67
5.6.	Calculation of the scenario with the highest impact on outdoor comfort	68
5.6.1.	Results of UTCI for point 1.....	69
5.6.2.	Results of UTCI for point 2.....	71
5.6.3.	Results of UTCI for point 3.....	72
5.6.4.	Results of UTCI for scenarios with vegetation.....	73
5.7.	Discussion of results	76
5.7.1.	Dry bulb temperature results comparison and discussion	76
5.7.2.	MRT results comparison and discussion.....	78
5.7.3.	UTCI results comparison and discussion	79
6.	Conclusions	81
7.	List of Figures	84
8.	List of tables.....	86
9.	References	Fehler! Textmarke nicht definiert.

Abstract

Microclimate in urban areas is becoming more important with the increased population density trend noticed in the past years, which will continue. The urban form has shown to be a critical parameter when calculating the outdoor comfort in the street canyon level. Using vegetation as a mitigation strategy for decreasing the negative consequences of a denser city is gaining more attention. At the street level, trees are considered to have the highest impact on citizens' comfort, which is why they are the central aspect considered in this study. To understand the effect different scenarios of densification and greenery cause on outdoor comfort in the summertime, a block of buildings in the urban area of Kempten, Germany, was studied. This case study analyzed an urban block densification possibility by considering the current scenario, three different densification scenarios, and the application of vegetation scenarios. A 3D model was created for all the densification scenarios using Rhinoceros 3D, and the effect in the microclimate was simulated using the Grasshopper plug-ins called Ladybug tools. The urban heat island phenomenon was considered in this study using the Urban Weather Generator (UWG) to account for the difference in climate conditions that these changes cause in the considered urban block. Results show that densification effects vary during day and nighttime. During the daytime, the street canyon temperatures decrease because of the increased shading that new buildings or floors bring into the canyon. The highest reduction in daytime UTCI is, on average, 2.69°C. However, the temperatures tend to increase during the night because the wind speed and Sky View Factor get reduced so that less heat can dissipate from the urban canyon. This increase has a maximum average of 0.23°C. The Universal Thermal Climate Index (UTCI) is chosen in this case to calculate the difference between the scenarios. The results show that the intelligent addition of trees in areas where high heat stress is experienced can reduce the values of UTCI up to 7.4°C, bringing it into a moderate heat stress state. Outdoor comfort and urban heat island simulations provide valuable information about the thermal behavior of urban areas, thus allowing planners to consider the effects of densification and develop adaptation measures.

Keywords:

Outdoor comfort, Ladybug tools, Urban Weather Generator, Tree coverage, Universal Thermal Climate Index

Kurzfassung

Das Mikroklima in städtischen Gebieten wird immer wichtiger, da sich der Anstieg der Bevölkerungsdichte in den letzten Jahren voraussichtlich auch in Zukunft fortsetzen wird. Es hat sich gezeigt, dass die Stadtstruktur ein kritischer Parameter bei der Berechnung des thermischen Komforts auf Straßenebene ist. Der Einsatz von Vegetation als Strategie zur Verringerung der negativen Folgen einer dichteren Stadt gewinnt zunehmend an Aufmerksamkeit. Auf Straßenebene haben Bäumen den größten Einfluss auf das Wohlbefinden der Menschen, weshalb sie in dieser Studie als zentraler Aspekt betrachtet werden. Um zu verstehen, wie sich verschiedene Szenarien der Verdichtung und Begrünung auf das thermische Behagen im Sommer auswirken, wurde ein Gebäudekomplex im Stadtgebiet von Kempten untersucht. In dieser Fallstudie wurde die Möglichkeit der Verdichtung eines städtischen Blocks analysiert. Dabei wurden die aktuelle bauliche Situation, drei verschiedene Verdichtungsszenarien und zwei Begrünungsszenarien berücksichtigt. Für alle Verdichtungsszenarien wurde ein 3D-Modell mit Rhinoceros 3D erstellt, und die Auswirkungen im Mikroklimamodell wurden mit den Grasshopper-Plug-ins Ladybug-Tools simuliert. Das Phänomen der städtischen Wärmeinsel wurde in dieser Studie mit dem Urban Weather Generator (UWG) berücksichtigt. Die Ergebnisse zeigen, dass die Auswirkungen der Verdichtung tagsüber und nachts unterschiedlich sind. Tagsüber sinken die Temperaturen in der Straßenschlucht, weil neue Gebäude oder Stockwerke mehr Schatten spenden. Die höchste Senkung des UTCI beträgt im Durchschnitt 2,69°C. In der Nacht steigen die Temperaturen jedoch tendenziell an, da die Windgeschwindigkeit und der Sky View Factor reduziert werden, so dass weniger Wärme aus der Straßenschlucht abgeführt werden kann. Dieser Anstieg beträgt im Durchschnitt maximal 0,23 °C. Der Universelle Thermische Klimaindex (UTCI) wird in diesem Fall verwendet, um den Unterschied zwischen den Szenarien zu berechnen. Die Ergebnisse zeigen, dass die gezielte Setzung von Bäumen in Gebieten mit hohem Hitzestress die Werte des UTCI um bis zu 7,4°C senken kann, wodurch ein moderater Hitzestress erreicht wird. Die Simulationen des Außenkomforts und der städtischen Wärmeinsel liefern wertvolle Informationen über das thermische Verhalten städtischer Gebiete und ermöglichen es so den Planern, die Auswirkungen der Verdichtung zu berücksichtigen und Anpassungsmaßnahmen zu entwickeln.

Acknowledgments

Firstly, I would like to thank my thesis supervisors, Farzan Banihashemi, Roland Reiterberger, and Prof. Lang (Institute of Energy Efficiency and Sustainable Design and Building (TUM)), for their continuous help and readiness throughout this work. Many thanks for helping to make this thesis possible and for the insightful recommendations and information on the process. I would also like to express my appreciation to Sabrina Erlwein (Chair for Strategic Landscape Planning and Management) for her great help regarding my vegetation scenarios and the addition of trees in the studied area. I would also like to mention Ata Chokhachian (Chair of Building Technology and Climate Responsive Building), who gave me the first insights on working with Pando.

Next, I would like to thank my big Oskar von Miller Forum family for always finding a way to make stressful situations pass unnoticed and always being supportive and open to help. I want to point out Gizem Eryenilmez and Simon Espinosa Leon for the continuous moral support and the most needed “no more work” plans, as well as Jakob Deffner, who made stressful thesis days easier, and his great pieces of advice in situations I felt stuck. Moreover, I would like to thank Marit Fuchs, Florian Meier, and Timo Harboe Nielsen for their support and feedback both regarding the thesis and my future career as part of the mentoring program from OvMF.

Lastly, I would like to express my biggest appreciation to my family for being my support system throughout my career and always believing in me. I want to point out my father for being the main source of my motivation and for being two parents at once.

List of Abbreviations

DBT	Dry bulb temperature
DF	Dragonfly tools
HB	Honeybee tools
HVAC	Heating, Ventilation and Air Conditioning
LB	Ladybug tools
MRT	Mean Radiant Temperature
Rhino	Rhinoceros 3D
SHGC	Solar Heat Gain Coefficient
SVF	Sky View Factor
UHI	Urban Heat Island
UTCI	Universal Thermal Climate Index
UWG	Urban Weather Generator

Glossary

U value – gives the value of heat transfer through a combination of materials such as a window, wall, or a simple material such as concrete or insulation.

SHGC – gives the amount of solar radiation which hits a window or its assembly that gets transmitted through it. This value considers the amount transmitted in the whole window assembly and takes values from 0 to 1.

Albedo – gives the amount of solar radiation which gets diffusely reflected by the material under study. It ranges from 0, meaning the material absorbs all solar radiation, to 1, indicating the material reflects all of it.

SVF – gives which areas of the sky are visible from a certain point, and its values range from 0 to 1.

1. Introduction

According to The World Bank, 4.43 billion [1] people in 2021 live in urban settlements, which accounts for 57% of the whole population [2]. The urban population in 2050 is estimated to reach 68%[3]. In Germany, as of 2021, 78% of the population lives in urban areas, which is higher than in most other countries. [4] The annual urban growth for 2021 was 0.1% [5], which shows that the urban population continues to grow in contrast to the country's total population[6].

In recent years, due to this increase in urban population and the limited land for housing inside cities, there has been a development towards its outside borders known as the urban sprawl phenomenon. [7] In Germany, 70.09% of the cities have and continue experiencing urban sprawl. This conclusion was drawn by the World Bank when comparing the increasing footprint of German cities and their declining population with a percentage of 0.11 each year. Also, the built-up area growth in Germany has increased by 30,22% from 2000 to 2013. [6] This phenomenon is considered to be a non-sustainable way of development due to the adverse effects that come with it. For example, since cities increase in size, longer distances must be traveled [7], meaning higher gas consumption and consequently higher CO₂ emissions.[8] The increase in urban footprint implies an increase in waste heat and deforestation [8] and a decrease in natural and agricultural land [9]. Very often, this way of developing cities is denoted as “scattered development,” and it is considered to have many negative effects on sustainability. [9] This phenomenon is often related to higher energy consumption, mainly for buildings and transportation. [10] If the city development continues this way, soon, traveling in the city will not have feasible distances. [11] As a response to the mentioned issues, the idea of urban densification and the compact city came into play as a sustainable way to refrain cities from expanding, which is used globally as a planning policy. [9] A city should, though, have both dense and not dense areas, coming from the outskirts with a lower value of inhabitants to the center core of the city where we have the highest densification. A separation into six sub-groups is proposed for cities: „*T1: Natural Zone, T2: Rural Zone, T3: Sub-urban Zone, T4: General Urban Zone, T5: Urban Center Zone, T6: Urban Core Zone.*“ [12, p. 268] However, the idea of urban densification can also be limited by the current state of the cities. In cities, where the population is already quite dense, this can be more challenging to apply. It is also important to consider sustainable development when densifying cities; one way could be by re-using land, allowing for

denser cities without taking additional land. [11] The concept of compact cities, however, opens many other questions when it comes to the microclimatic comfort or the air quality in the urban area. A topic that requires special attention is the increase in outdoor thermal stress, which can be caused by this increase in the compactness of cities. [13]

Urbanization and densification of cities are closely related to the Urban heat island effect, which is a description of the differences noticed in temperatures in urban areas compared to the surrounding suburbs. [14] Due to the increased housing demand, the number of buildings is increased, and heat-absorbing materials are used, leading to higher temperatures inside the cities. [15] UHI is mainly noticed in the summertime and at night, where we see an increase in air temperatures and pollution in the air compared to suburbs. [14] As methods to reduce these adverse effects of UHI and densification scenarios, widely known are the usage of impervious materials in buildings and, most notably, the use of vegetation, whether trees, green facades, or rooftops. Greenery can help in reducing air temperature, and improving air quality, and can be related to a more comfortable and pleasant environment for the inhabitants. [15]

On local scales, has been noticed a strong interconnection between densification scenarios, exposed or shaded areas, greenery scenarios, and outdoor thermal comfort or air temperatures. [13] Urban densification has not been much considered in urban climate calculations and has been studied primarily on a macroscale and less at a district or neighborhood level. [16, p. 2] [9] That is why it is of particular interest to consider how the compactness of a city influences on a local scale, meaning a neighborhood or even less in an urban block.

This study aims to understand how much densification can affect outdoor thermal comfort when applied on a micro-scale (urban block), whether horizontally or vertically, and further on how greenery can help improve citizens' comfort.

The content of this thesis includes the following. Firstly, an introduction to the current studies conducted for urban densification as a phenomenon, and the use of vegetation as a method to regulate urban microclimate will be held. Further, we will introduce the methodology and the tools used to calculate the outdoor comfort of citizens. This procedure will then be applied to a specific case study in chapter 4. Lastly, we will have the results for our study area and the discussion and comparison to previous studies. To conclude this work, the conclusion drawn by the results and limitations of the thesis and possibilities for further studies will be presented.

Research question and Hypothesis:

The research question of this study is:

How much is outdoor comfort in an urban affected by the Urban Heat Island effect and further densification of the city, and can we reduce this effect by mitigation strategies like green infrastructure, e.g., trees?

This question is separated into different subtopics. Firstly, what effect does the denser urban form have on the dry bulb temperature, which will be initially taken from a weather station on a single-family houses district in Kempten. Therefore, the initial part of this research question will focus on the Urban Heat Island effect and the changes that come because of it on the microclimate.

Secondly, the effect on outdoor comfort of different densification scenarios has to be evaluated to propose mitigation strategies for a more comfortable urban environment. The second part of this research question will focus on determining how different ways of densifying the city affect people's comfort at the street level.

The third subpart deals with how much can addition of trees influence outdoor comfort, and as a consequence, the goal of this part is to understand the compensation potential of trees on a local scale.

For the purpose of this thesis, we have used two hypotheses:

1. The horizontal densification scenario creates the highest impact on the change of temperatures in the urban area since we have increased shading area and building mass.
2. Greenery, in this case, adding trees, can help improve outdoor comfort in dense areas.

2. State of the art

This chapter will present an overview of current studies related to several relevant topics to this thesis. Firstly, a short introduction to the UHI effect and different types of used densification strategies with a deeper focus on two types which will be conducted in this thesis, will be presented. Further, studies that explain the effects of densification in microclimate and mitigation strategies (especially vegetation) used to reduce the negative impacts will be summarized. A comparison between two different models for the creation of the new urban weather file will be described. Lastly, the reasoning behind the choice of the thermal index used in this thesis will be shown through a comparison with another commonly used index.

2.1. Urban heat island effect

The change of land surface for building purposes leads to the alteration of air temperature between urban and rural regions, which is differently known as the urban heat island effect. [17, p. 2532] The effect of densification in UHI is very often dependent on the specific study area, which has led to controversial results between different studies and makes it more difficult to create policies for urban planning. [18, p. 182] Urban sprawl and densification affect the UHI differently, respectively, by increasing the area affected by it and, at the latest, by increasing its magnitude. [17, p. 2532] Due to the rapid growth in urban population and, therefore, the creation of denser cities, the UHI effect has increased over the last years, and this is an issue that can cause problems, especially in cold climates.[19] Depending on the climatic and building conditions, the intensity of the UHI varies; however, the average value of it is known to be 2°C [17, p. 2532]. According to a study in an Australian city, the heat island effect was more intense in the case of extreme heat days compared to typical summer days. [17, p. 2540] The increase in temperature in the urban areas is caused mainly by higher anthropogenic heat, less possibilities for vegetation, reduction of heat released in the atmosphere due to the lower sky-view factor, change in the total urban albedo due to the addition of buildings. [17, p. 2532] UHI can have different scales in the city, often it is also assessed in the atmosphere above a city, however, the UHI effect relevant for comfort at the street level is measured more in the street or building level and is divided into two cases: the canopy heat island which describes the temperature difference in the air in rural and urban areas

and the surface heat island which describes the temperature difference on surfaces. [20] The difference between these two types of heat island is more visible during the day with higher surface values, while at night, they are more similar. [20]

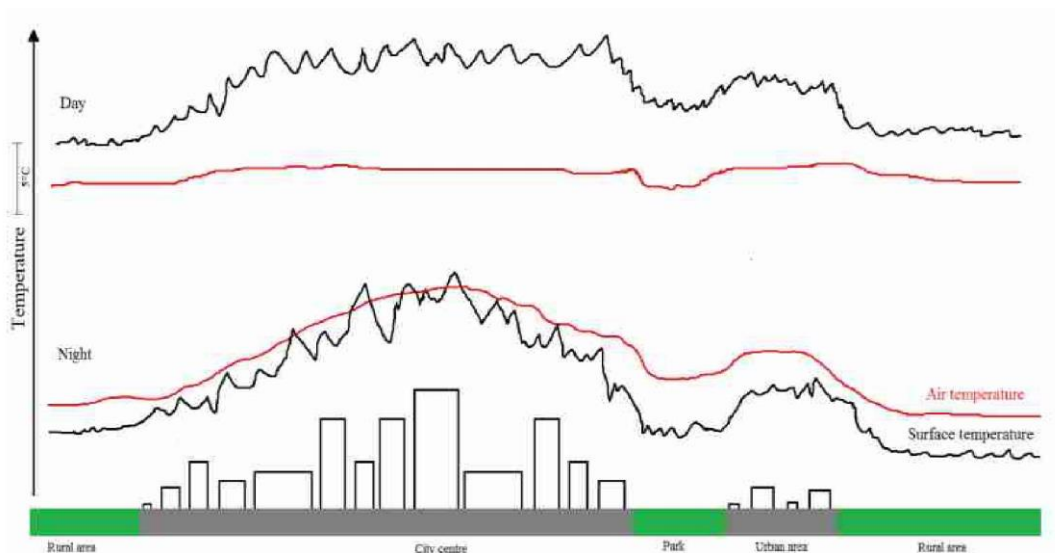

Figure 1: Erlström 2020 - Urban heat island effect [20]

2.2. Comparison of types of densifications

They are many strategies proposed on a city scale for containing the further sprawl into the suburbs. „Green Belt” is one of the strategies highly implemented in Germany, which means having a green layer surrounding the city in order to prevent it from taking too much of the suburban areas and also not allowing cities to connect. However, this might bring negative consequences depending on the width of the belt. [7, p. 6] “Urban growth boundary” is another scheme to stop urban sprawl, which means a clear division between the urban and nearby rural areas which can, later on, be changed depending on the population's demand. [7, p. 6] The last scheme, which allows the further sprawl of the city but stops the development of urban infrastructure after a specific limit line, is called the “urban service boundary strategy”. [7, p. 6] When it comes to a smaller scale, in a neighborhood or block scale, densification happens in two ways: horizontally, so the creation of new buildings, or vertically, so in already existing buildings. They are five different types of densification methods:

1. Filling the "backyards"
2. Infilling of vacant lots

3. Densification by roof stacking

4. Transforming of saddle roofs

5. Demolition and re-building [7, p. 8]

It is, however, crucial to consider where the densification of these neighborhoods happens. [10] It makes a higher impact when densifying well-located city areas, with good public transport connections and connections to parks or leisure areas, as they would bring less dependency on cars and reduce CO₂ emissions [7, p. 7] [10]. Since in our study, we will use two of these densification strategies, in the upcoming subchapters, we have a brief introduction to both of them.

2.2.1. Densification by roof stacking

Roof stacking will be one of the methodologies used in this master thesis, as it is a simple method of densification to apply in already built urban areas similar to the one we are studying. It has such positive effects as keeping the open space and space for greenery as no new buildings are added and also reduces the energy consumption of existing buildings as it is well known that a lot of the energy loss in old buildings comes from convective heat loss over the roof. [7, p. 11] To achieve sustainability goals, it is, however, not enough to densify the city without making any interventions in the existing block. The process of vertical extensions and renovation of the existing blocks would roughly need four months, whether it is done with wood or steel (the most common constructions used for this type of densification). [21, p. 83] This type of densification also depends on the local building code because it can be limited from the maximum building height of the area. [7, p. 11] However, a study in Brussels, the capital of Belgium, came to the conclusion that with today's regulation, 32% of the demand for housing or 60400 inhabitants by 2040 can be covered by roof stacking. [7, p. 2] This number is slightly reduced due to the actual structural conditions of the building with a non-significant change of 2% [7, p. 25]. If the building laws were more flexible, the potential for roof stacking would be way higher; however, this opens other question marks like the actual strength of the soil and the maximum weight it can handle. [7, p. 28] Penthouse is one of the most common constructions on the rooftops of buildings which has several benefits besides creating less waste and being a lightweight construction. [21, p. 87] In a study held in Brussels, they calculated a significant potential in roof stacking for the creation of new housing, but this is still limited compared to the expected population requirements, which makes them propose a combination of different scenarios for re-

densification. [7, p. 31] A sustainability study was conducted in Tanta, Egypt, where three different densification methods were compared to their applicability in areas that need re-densification. According to this study, in zones with very high demand, the roof stalking strategy was applicable in 91% of the cases. [9, p. 17] A research held in a neighborhood with low density in Gaz, Austria, calculated via Rhinoceros and grasshopper, showed that vertical densification theoretically allows for an increase of building volume by 60% of the actual state. [22]

2.2.2. Densification by infill strategies

Infill development will be the second densification strategy used in our study as it is another densification strategy considered applicable in most cases. [9, p. 6] This type of densification considers the building of new housing or mix-used buildings in already existing areas, for example, parking lots or unused surfaces in the cities and the gaps between buildings. [9, p. 7] Also, in this case, there are specific building regulations that have to be fulfilled, like the minimum lot area, the maximum building height, etc. [9, p. 7]. A study conducted in Tanta, Egypt, showed that the infill strategy could account for an addition of 6361 new units compared to the required ones of 14.467, which means only 11% of the demand would be fulfilled compared to 41% through roof stalking because of the lack in lots where this strategy can be implemented. [9, p. 11] Furthermore, according to a study in 50 American cities, this type of strategy brings the highest negative effects on the development of UHI. [18, p. 192]

2.3. Densification effect on microclimate

Perceived thermal comfort outdoors, differs from indoors, and changes dynamically and from person to person. For example, the expectations people have when being in the shade differ from those in the sun. A study in a hot and dry climate in Madinah, Saudi Arabia, noticed that the occupancy of the street increases significantly during nighttime (after sunset) because of the perception a person has when exposed to the sun. [23] When assessing outdoor comfort in a specific climate, six parameters have to be firstly defined: Clothing insulation ratio, air temperature, mean radiant temperature, relative humidity, metabolic rate, and wind velocity. [23] These factors that affect the perception of comfort can be modified by the way the city or neighborhood is developed, so the position of buildings, their height, the types of materials used, the addition of water and green resources, etc. [23] The effect of urban density increase and urban form in out-

door comfort and microclimate has been studied intensively in the last years and continues to get substantial as climate change is becoming a concerning phenomenon. [13] The continuous increase in population in cities increases the amount of anthropogenic heat produced and, as a consequence, contributes negatively to the UHI effect [16, p. 2]. Proposals for sustainable ways of city development are getting essential, and studies concerning compactness/densification and mixed-use of lands are conducted intensively. In the scope of vertical or horizontal densification, the horizontal one appears to have a higher impact on the local climate since it reduces the number of vegetation areas possible and, therefore, less possibility for temperature regulation. Tall buildings are considered to “free up more open space,” and the possibility of blocking wind corridors is lower than when adding new construction. When planning cities, it is crucial to consider the connections between shading, ventilation, and urban form on a local scale, as only in this way can we create dense and comfortable living spaces. [13] However, the decisions taken with respect to local densification can significantly vary from one location to another, depending on what type of climate we are considering. [11, p. 49]

A study in Canada considered the existing state of the urban canyon and the change in temperatures after adding new constructions, so after horizontal densification. During the day, because of the high shading created by the new construction, a decrease of almost 1 degree was noticed. [19] A research in Meidling, a district in Vienna, compared the difference in MRT of the actual state of the district with a vertical densification scenario. This scenario comes with taller buildings and, consequently, more shading in the streets, so a decrease of 4K in average daily MRT was noticed. [16, p. 11] Although the average MRT got reduced for the whole day, in this study, they made a differentiation between daytime/nighttime and noticed that during the night, the temperatures are higher in the case with densification because the heat trapped in the street canyon cannot dissipate to the atmosphere due to deeper canyons. [16, p. 12] Another scenario with two high-rise buildings was simulated, and the results showed that during the daytime, because of shading, the MRT dropped from 38 to 23 in the zone close to the buildings, while during the night, the increase in temperature was only 0.5K. [16, p. 12] Therefore, it is essential to consider the positive and negative impacts that densification can bring to outdoor microclimate depending on the specific urban morphology and climate of the studied area.

2.3.1. Importance of the albedo of materials and their effect in micro-climate

As mentioned in the previous chapter, densification can bring negative impacts, especially in nighttime temperatures; therefore, it is essential to find solutions that can help reduce these impacts. [16, p. 12] One of the proposed ways to reduce trapped heat inside urban areas is to use reflective materials, so materials with high albedo. [24, p. 1] These are called "cool materials" [25] as they are known to have low surface temperatures [26, p. 5], which, if used smartly, can help in the reduction of the UHI effect [25], and allow less heat to be transmitted inside the buildings in the case they are used in the building envelope [24, p. 1]. However, this increase in reflectance of materials could create an uncomfortable environment for closed spaces in urban areas at the street level on a hot day. When it comes to increasing the reflectance of the street material, a negative impact on outdoor comfort is noticed, for example, on the hottest hour of the day because the heat gets reflected in the pedestrians, causing discomfort [24, p. 9], which means even though the temperature on the surface is lower, it increases the air temperature above it [27, p. 33]. This would also bring higher wall temperatures due to the reflection of the pavement [28, p. 832]. High façade reflectance has no significant improvement in PET, while reducing the reflectance improves outdoor comfort due to the reduction of reflections between the buildings. [24, p. 10] Consequently, high albedo materials can also bring discomfort, which is why an appropriate combination of them should be considered depending on the urban geometry. In a study in London, a combination of low facade reflectance in the lower level (close to pedestrians) and high reflectance of streets, but not at the pedestrian path, showed the best impact on outdoor comfort. [24, p. 10]. In a study performed in Argentina, an increase in horizontal albedo (roofs, floors) brings a higher decrease in outdoor temperatures for less dense urban areas. In contrast, when it comes to increasing vertical albedo (walls) for high densified areas, the temperatures increase. [29, p. 11] New materials which can reflect the light in the same direction it arrives are under study to avoid this adverse effect that high reflective materials can bring; however they are still in the early study phase [25, p. 79] and they are not yet widely available [29, p. 10] The most efficient way is the increase in horizontal surface albedos, preferably in combination with vegetation. [29, p. 13] Vegetation remains, therefore, the most successful way to mitigate the negative effect of UHI [24, p. 10], whether considering the global, surface, or air temperature [27, p. 33]. This is also why it is more extensively studied in this thesis.

2.3.2. Greenery as a mode of reducing the adverse effects of densification on microclimate

Vegetation is considered one of the ways to mitigate the effect of UHI and the negative consequences that might arise in the urban microclimate due to the increase in building density. [16, p. 3] For a local scale study, the best greenery scenario is the addition of trees which bring cooling effects due to shading and evapotranspiration [30, p. 1]. Trees can be used as a mitigation mode in zones with heat stress in urban areas because their pattern can block solar radiation (see figure nr.2). [31] However, there are many factors to consider when using vegetation as a mitigation method; for example, it makes a more significant difference a smart distribution of greenery through the area than just a random placement of trees. When applying green facades or trees in the street, it is recommended to have vegetation that loses leaves in winter as it is the period when we want to get as much solar radiation indoors as possible. Vegetation has proven to be a regulatory measure with respect to outdoor temperatures both in the summer and winter periods. [16, p. 3]

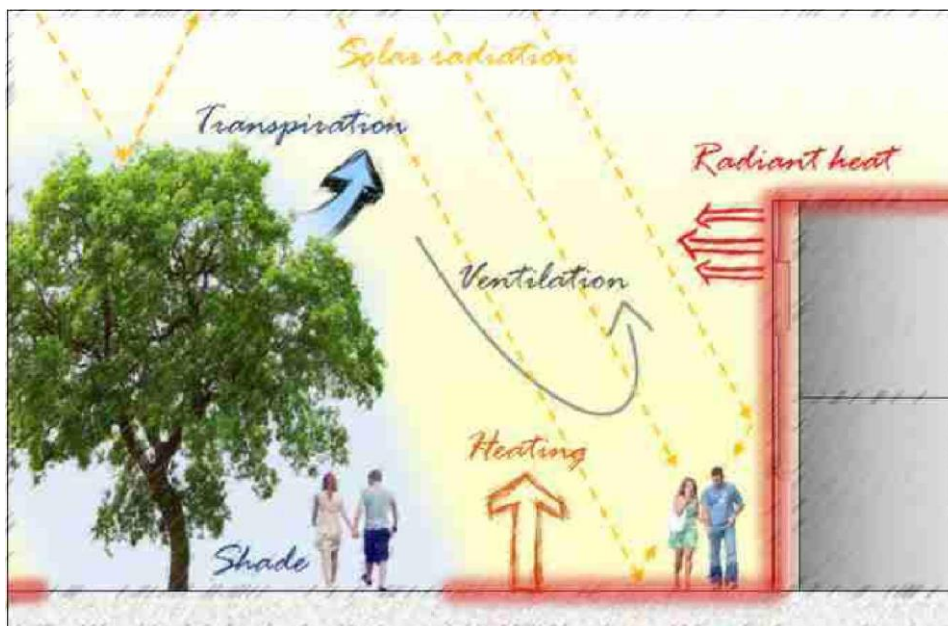

Figure 2: How does human comfort get affected by the environment [32]

A comparison of the densified scenario with the addition of greenery in a district in Vienna showed a reduction of up to 7K on the average daily MRT, with not only good impacts on the pedestrian level due to evapotranspiration and shading but also on the building energy consumption as they also provide shade for the buildings. [16, p. 13] Concerning their effect on microclimate at street level and their cooling effect, we can

say that the green scenarios from the most influential to the least are: trees, green facades, and green roofs as adding greenery to the rooftop has only a minor influence in the street level of about 0.5K. [16, p. 14] It is essential to have a smart implementation of green spaces, which are mainly effective during daytime in open zones with a potential of lowering the MRT up to 10 degrees. [20]

Two neighborhoods in Dar es Saalam in Tanzania with a warm and humid climate were analyzed for the effect vertical densification has on micro-climate with the plug-in of Grasshopper, Envi-Met. According to E. Johansson and M. Yahida, the effect of shading plays a higher effect on cooling rates for MRT than vegetation during the daytime. The first neighborhood consists of higher buildings after densifying, that is why at noon, due to the high amount of shading, the temperatures are lowered significantly compared to the second neighborhood with shorter buildings and higher vegetation rate [33, p. 5]. However, this positive effect of shading is still to be questioned regarding the reduction in wind speed these high buildings cause, meaning less heat dissipation from the wind. [33, p. 6] This study comes with the proposal of combining different building heights to make a good combination between shading and also allowing wind pathways. [33, p. 7]

In a research in a block in Drottninghög, Helsingborg, it was assessed that the lowest MRT for the current building scenario values are calculated below trees during the daytime, showing that they are an excellent temperature regulator. This was assessed for both a typical summer and an extremely hot summer. In the case where no trees would have been implemented, the temperatures in the street canyon(MRT) would be around 10 degrees more. [20]

2.4. Urban Weather Generator and Vertical City Weather Generator

The Urban Weather Generator is a fast computational model proposed for calculating climate conditions in an urban area by taking as input data from a weather station outside of the urban area. [34] The model requires two input files: firstly, a .xml file which gives the parameters of the studied area both at the weather station and the urban area; secondly, a .epw file which gives the weather data for the weather station site. [35] Input parameters that have the highest impact in calculations with UWG are the facade to site

area, the building, and vegetation density. [35] UWG focuses on the calculation of humidity and air temperature in the urban area from a combination of four different modules. [34] These four modules are separated into two for the urban area and two for the rural area where the weather station is located. For each of the areas calculated (so urban and rural), two separate modules are used: the first module calculates air temperature, humidity, and sensible heat fluxes inside the urban/rural canyon; The second module calculates the air temperature above the urban/rural canopy. [34] One of the drawbacks of the UWG model is that it does not have a detailed calculation of the evapotranspiration effect of vegetation, but it includes it with an approximation as if 50% of the solar radiation gets converted into latent heat in the calculation of shortwave radiation. In addition, the effect of trees in the Sky View Factor and, as a consequence, in longwave radiation is neglected due to assumptions made for creating the model [34], such as the leaf temperatures considered to be the same as air temperature [36, p. 12]. The UWG model does not consider the precise location of trees but only considers the percentage of tree coverage in the urban area. [36, p. 11] Furthermore, the calculation with the model does not make a difference in the humidity values between the rural and the urban environment [34], and neither does it consider the disturbance in the wind direction and speed that happens inside the street canyon [35]. This model has been compared to field data in France and Switzerland [34] and also for varying weather conditions [35], giving acceptable results, and it is recommended to be used for [34] calculation of the UHI effect [35] in the building energy consumption or calculation of weather conditions in a specific urban area [34]. Several studies observing the accuracy of UWG have been conducted until today, showing that the model's performance is higher for homogenous urban areas and moderate wind conditions [37]. The results taken from the model are still relevant even though, for their calculation, certain assumptions have been made, as mentioned above. [35]

The Vertical City Weather Generator is another developed computational model for calculating humidity, kinetic energy, air temperature, and wind speed in urban areas. Similar to UWG, it contains four separate modules. [38, p. 961] VCWG works similarly to the UWG model, which means it is also coupled with a building model, but in this case, the data calculated for the urban area is no longer limited to a single layer (the middle of the urban canyon) but can be calculated in different vertical positions. [38, p. 963] Another important advantage of the multi-layer model is the detailed representation of trees and their effect on different climatic parameters. [38, p. 963] However, one of the

drawbacks of this model is the building's shape input as it is simplified into symmetrical boxes. Furthermore, there is a place for improvement in the building energy model as it does not calculate the change in temperature that happens at different heights of the building. [38, p. 977] This model takes parts of previous models, including also UWG, and creates a model which can calculate different vertical profiles which have been studied concerning field values showing acceptable results showing potential to change from single-layer models to multi-layer ones. [38, p. 977]

Despite the advantages the second model offers, in the scope of this thesis, we will be using the UWG model as it is included in the Ladybug tools [39], which will be later on used for the calculation of outdoor comfort. This could be an open scope for future study.

2.5. Comparison of UTCI and PET for calculation of outdoor comfort

Thermal comfort/discomfort of human bodies is usually expressed by different comfort indices, which result from a combination of several climatic parameters like Mean Radiant Temperature, air temperature, wind velocity, and air humidity. [40] The perception of the thermal environment by people is expressed using thermal indices. Thermal indices for assessing changes in comfort are several; however, here, we will only explain the difference between Physiologically Equivalent Temperature (PET) and the Universal Thermal Climate Index (UTCI). [40] PET evaluates the air temperature for the outdoor environment, which would lead to balanced human body energy with equal skin and core temperature for the indoor environment, where no wind or direct solar radiation is available. [41] PET has been broadly used in the last 20 years in different scales of studies. [41] UTCI is a later developed index and had as its purpose the creation of a standard parameter that could be used internationally to understand the physiological and thermal response to change in climate conditions of humans. [41] This index compares different meteorological conditions to a reference one called "UTCI equivalent temperature," which also follows the concept of combining different climatic parameters like air temperature, wind, humidity, and radiation. [41] UTCI and PET are both parts of the RayMan model [41]; however, in most studies related to climate comfort with ladybug tools, evaluations of the calculation model for UTCI have been made. These studies show that further improvements can be made, but Ladybug tools are the most convenient tools for running long simulations, for example, yearly. [42] Ranges of values for thermal stress (as it is what the values compare) calculated with both indices can be checked in table nr. 1.

Table 1 PET and UTCI values range concerning thermal stress [41]

UTCI Range (°C)	PET Range (°C)	Stress Category
above +46	above 41	extreme heat stress
+38 to +46	35 – 41	very high heat tress
+32 to +38	29 – 35	high heat stress
+26 to +32	23 – 29	moderate heat stress
+9 to +26	18 – 23	no thermal stress
0 to +9	13 – 18	slight cold stress
-13 to 0	8 – 13	moderate cold stress
-27 to -13	4 – 8	high cold stress
-40 to -27	below 4	very high cold stress
below -40		extreme cold stress

Differently from PET, UTCI does not consider standard clothing coefficient, but it varies it depending on changes in clothing that happen due to body movement or wind, due to typical clothing in different temperature settings, etc. [41] Secondly, UTCI and PET measure wind velocity in two different altitudes, respectively 10m and 1.1m (the gravity center of the human body). [43, p. 50] The comparison between UTCI and PET is more straightforward in warm periods, and the results show not to have considerable differences, however, in cold periods, it is not so easy to compare them due to the variable clothing factor included in UTCI. [41] UTCI is recommended when it comes to a humid and warm environment and also has a more relevant approach for expressing cold stress [41] and also heat stress which in PET sometimes is overestimated [43, p. 59] mainly due to the change of the clothing parameter [43, p. 59]. Different climate conditions are better expressed using UTCI because this index also expresses small changes that happen in one of the input parameters. [44, p. 953] As a consequence of all the mentioned advantages and since it is easily accessible with the ladybug tools for this master thesis, we will compare depending on the thermal index UTCI.

3. Methodology

This chapter will include the methodology used to evaluate outdoor comfort change with the influence of densification and trees in the chosen urban area. Firstly, an overview of the chosen path and different scenario divisions will be explained. Secondly, the tools used to calculate outdoor comfort will be briefly introduced, as well as the connections between them. Lastly, the parametric flow will be explained step by step from consideration of the UHI effect until the calculation of the UTCI.

3.1. Overview of research methodology

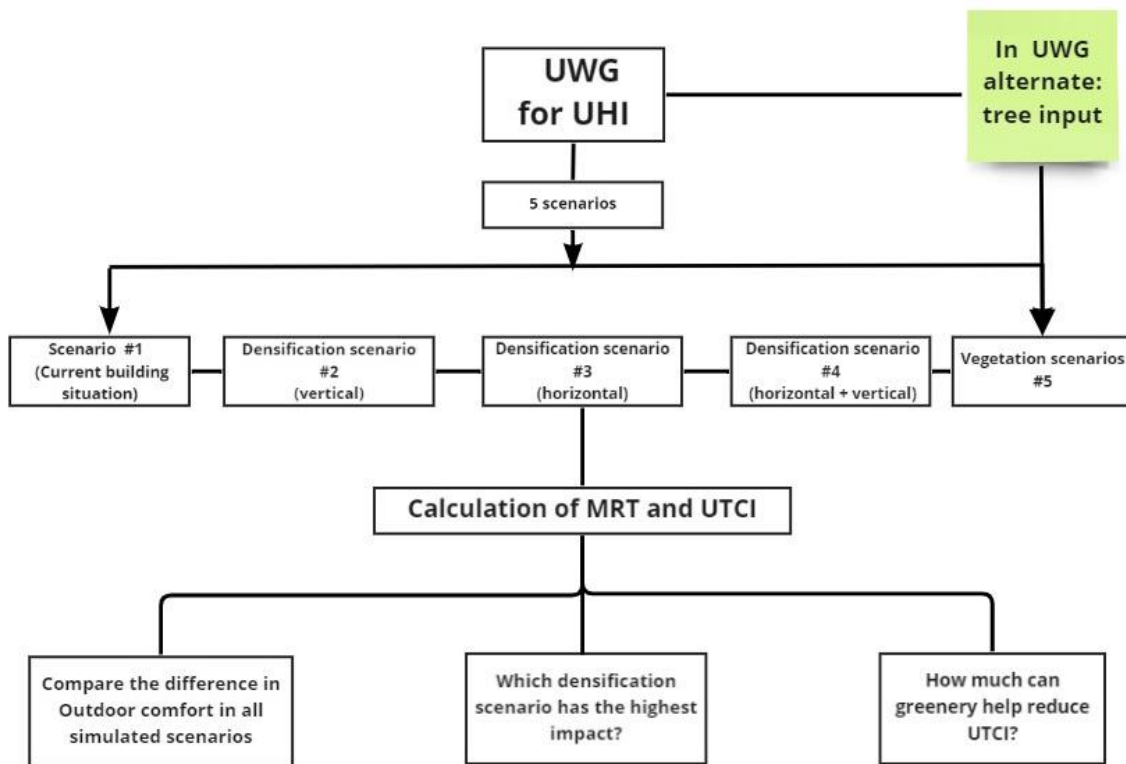

Figure 3 Thesis methodology diagram

This research will be based on comparing different densification scenarios with the current status of the building's site and further on adding vegetation scenarios. The densification scenarios consider the addition of new flats, whether by the addition of new floors or the addition of new buildings.

The greenery scenarios will initially include the attested conditions of green infrastructure in the study area and will continue to the calculation of an adequate greenery ratio to improve the outdoor comfort of citizens in the study area. It is essential to clarify that the scope of this study remains limited only to the addition of trees as a vegetation method due to the fact that it is considered to be the most influential one in the outdoor comfort of citizens [43].

This study will focus on simulations of outdoor comfort (mainly Urban Thermal Climate Index), carried out with Grasshopper and its plug-ins called “Ladybug tools”. For the simulations mentioned above, the first step will be to consider the effect of the Urban Heat Island by using the “Urban Weather Generator” (UWG), another Grasshopper plug-in.

Very often, weather stations, where outside temperatures, wind speed, and humidity are calculated, are located in areas that do not represent an urban environment. Often, they are located in open areas such as airports or in locations with single-family houses, where the density of buildings and obstacles is not so high. The air temperatures taken from these stations mainly differ from the actual temperatures inside the city. This happens due to more heat reflections in between the buildings, the lower wind velocity as a result of higher roughness inside cities, less space for vegetation, so less evaporative cooling, more anthropogenic heat, and more built mass density. [34]

After the generation of the urban weather file with UWG, we will proceed to use the LB tools for the calculation of outdoor comfort. Two main reasons lead us to use these tools, which make them one of the most suitable models when it comes to microclimate studies. First, simulations take a shorter amount of time due to the fact that the model has simplifications, such as for the calculation of the long-wave radiation flux. Second, they are free for use and do not require such expensive licenses as other Computational Fluid Dynamics (CFD) tools. [42]

In this case, the thermal indices studied and compared among the scenarios will be MRT and UTCI. UTCI is the respective air temperature in the outdoor environment, which causes the same strain in an indoor reference site. It is an index developed in the last years as one of the indices to show the microclimate of an environment and takes as inputs relative humidity, air temperatures, radiation, and wind. [41] The study is conducted in a hot summer period, specifically in the hottest month of the year, and the results are divided into day and night periods.

3.2. Introduction to the software used for the parametric flow

The building geometry will be provided by simple building blocks in Rhinoceros 3D, which is a 3D modeling interface based on mathematical NURBS. [45] This software is widely used to create design proposals for city developments but does not include geo-data information. [45] Its high flexibility and the coupling with the Grasshopper plug-in give it a higher range of usage for parametric flows in urban design. [45] Grasshopper is a visual coding language that deconstructs the collection of boundaries (BREPs), which come as a result of CAD softwares to a collection of points. [46] Grasshopper can generate different workflows which help identify sustainable development of our build environments due to the ability to simultaneously analyze different factors like outdoor comfort, solar radiation, indoor comfort analysis, etc. Therefore, multiple possibilities can be evaluated, showing different urban development options which can be used to find the optimized solution. [45] The Grasshopper add-on can be used for running Dragonfly, Ladybug, Honeybee, and Pando [47, p. 5], which will be used in this thesis for analysis of outdoor comfort in the urban area. Ladybug is an available plugin of Grasshopper which, through parametric design, introduces environmental design analysis with the incorporation of advanced simulations like energy or daylight besides simple analyses like air temperature, etc. [48] One of the essential parameters of Ladybug tools is the combination of weather data, environmental analysis and building simulation in the same tools, which make it feasible to provide different initial options for the design phase. [48] Honeybee is another Grasshopper plugin more focused on the inside building design analysis with more detailed simulations like calculation of daylight and energy simulations for different zones of the building, taking however the same geometries for both to avoid any mistakes in inputs by the user. [48] The plugin Dragonfly can be used to prepare the buildings geometry and the characteristics of the urban environment in order to run the UWG [49] for the calculation of the effect of UHI in the city, for example, in the relative humidity or dry bulb temperature [50, p. 163]. The change in the surrounding environment caused by one or more additional buildings can be modeled with this plugin. [50, p. 163]

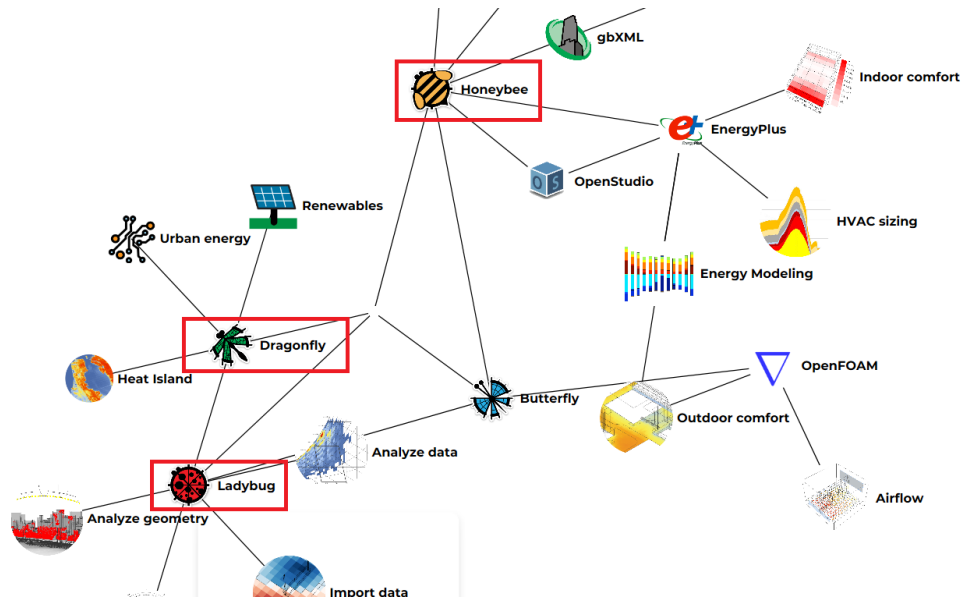

Figure 4 The connection between the different Ladybug tools and their different specializations [51]

Lastly, for the addition of the trees in the scenarios of this thesis, we used the simulation tool, Pando. It is a numerical process-based tool incorporated in Grasshopper and allows the design of trees and the creation of different plans for finding the optimal vegetation solution for a specific area. [52] Pando takes inputs such as geometry, water balance, weather data, and simulation setup to create tree canopies through a parametric flow written in python. [52] The connection between the tools used in this thesis can be seen in the following figure:

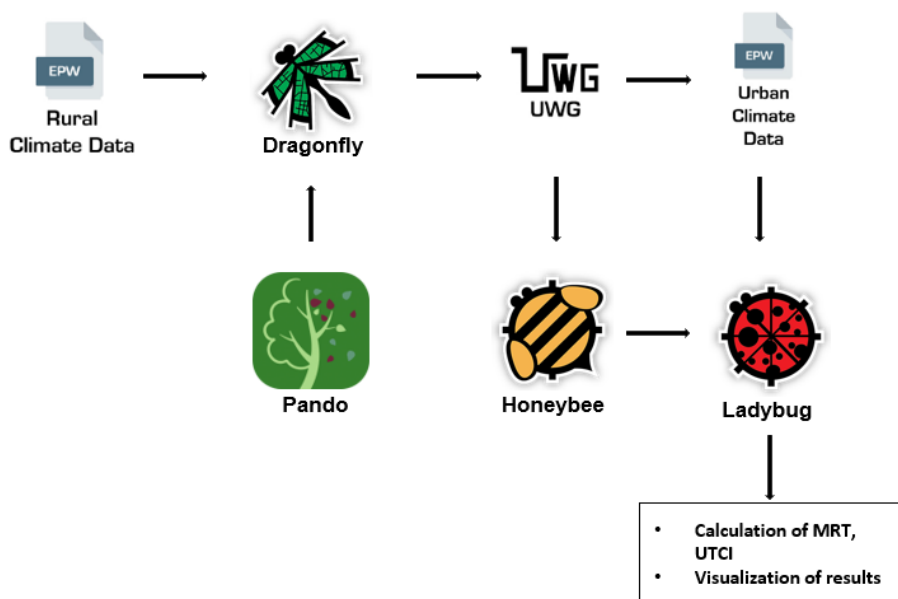

Figure 5 Connection of the tools used in the parametric workflow of this thesis [51] [53] [54]

3.3. Parametric flow for calculation of UTCI

In the following subchapters, an overview of the parametric flow used for calculating the UTCI will be given. These chapters will be divided into the steps used to create the final result, which is the “UTCI heat map” of the urban area. Furthermore, calculations of changes in dry bulb temperature and MRT will be discussed. The first step in all these scenarios is creating a new file in Rhino, creating all geometries, and creating a new Grasshopper tab.

3.3.1. Creation of buildings for the run of the UWG

Before starting the parametric flow, all the buildings under study and the surrounding ones are firstly created in Rhino with the help of polylines, surfaces, extrude, join, etc. To translate them into our parametric flow, we use BREP, which represents the 3D element provided in Rhino by a combination of surfaces with defined boundary connections [55]. For the creation of the buildings here, we use DF since the UWG generates a new weather file with a DF model.

We use the component “HB Search Programs” to define the type of buildings we are specifying in our case study; there is a variety of programs available, from Office buildings to Data Centers [56]. Furthermore, we use the component “HB Search Construction Set” to specify what type of construction our buildings have [56]. In order to create the Dragonfly building from the solid 3D geometries given in Rhino, we use the component “DF Building from Solid,” which requires as inputs a solid building geometry (so the BREPS), the floor-to-floor height, specify whether the building is conditioned or not and as well the two above mentioned parameters.

Until this point, the buildings are only added as simple boxes, and with the following two components, we can input the window parameters. We use “DF Repeating Window Ratio Parameters” to give values of glazing % in different directions of the buildings and the characteristics of those windows, such as the window height, the distance between windows, sill height, etc. In order to apply these window characteristics to our buildings represented by simple geometry, we use the component “DF Apply Façade Parameters”. [39]

The last component used for creating the buildings is “DF Assign Building UWG Properties,” where we can assign properties of the buildings but now related to essential

characteristics which can affect the UHI and the increase of temperatures in the urban area. Such components are the albedo of the walls and the roofs of buildings, the age of buildings, and the SHGC of the windows used in them. [39] In the following figure nr.6, we can see how these components are linked with one another:

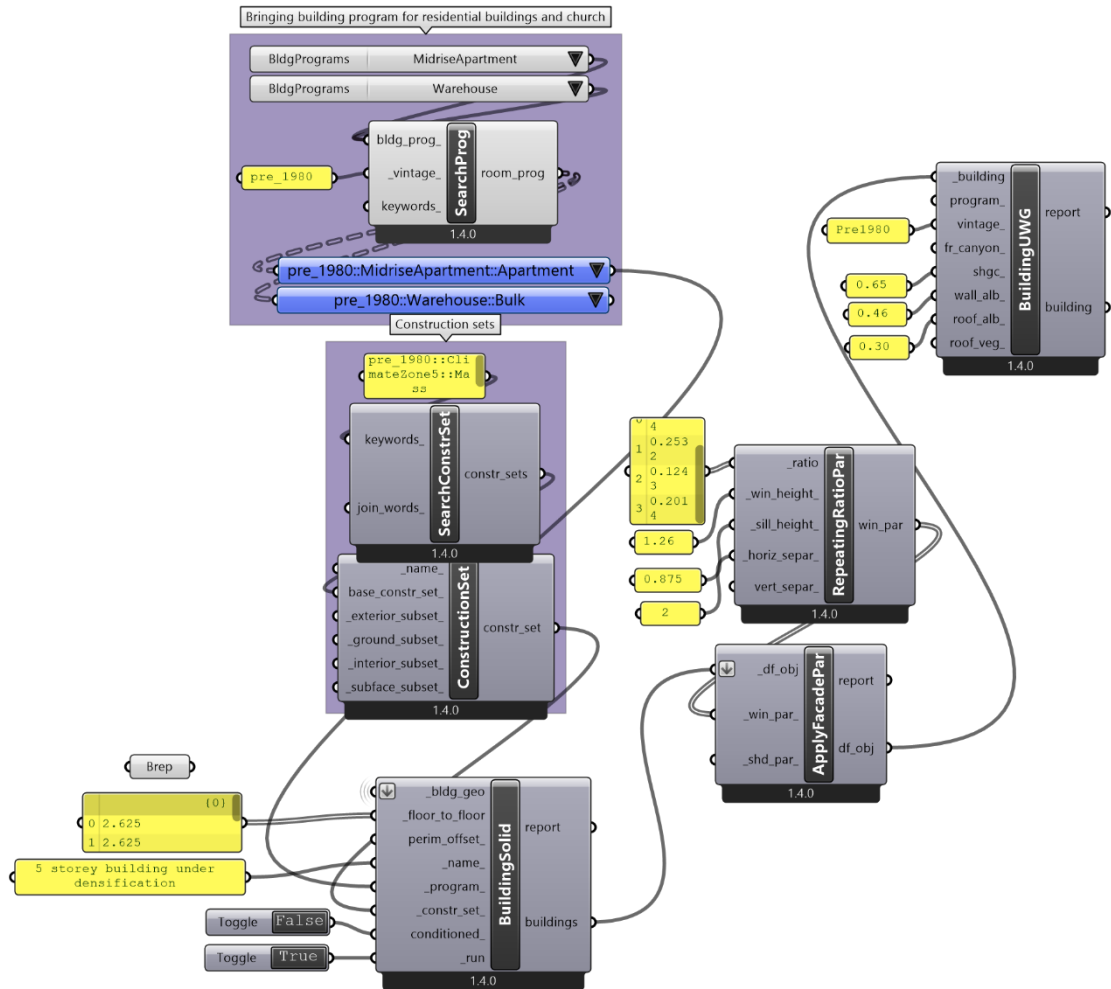

Figure 6 Parametric flow for the creation of buildings for the Dragonfly model

3.3.2. Running the UWG

In order to run the UWG and generate the new urban file, besides the building properties mentioned in the previous subchapter, we need to input detailed parameters of the urban area. The inputs of the UWG are: 1. Simulation parameters; 2. .epw file; 3. UWG model [39]

The simulation parameters are: 1. The analysis-period; 2. Information on the weather station site [39] Firstly, with the component “LB Analysis Period,” we can define the

period for which we want to generate the new urban file and also the amount of generated values we require per hour [57]. For the input of different properties of the weather station, the component “DF Reference EPW Parameters” is used where we can define the obstacle height, vegetation coverage, and the height in which temperature and wind were measured in the inserted weather file taken at a specific weather station. [39]

UWG model:

The component “DF Assign Model UWG Properties” requires the following inputs:

- DF model
- Terrain properties
- Traffic properties
- Tree coverage
- Grass coverage

The component “DF model” brings together the buildings created (explained in the previous chapter) with DF with other geometries from the component “DF ContextShade,” which can also be used to input trees as vegetation (used in the scenarios with vegetation). For the terrain properties, we use “DF Terrain,” a component used to specify properties of the material used as pavement in the urban area, such as the albedo value, thickness of the pavement, etc. [39] The component “DF Traffic Parameters” is used to define the anthropogenic heat in the urban area which comes from human metabolism, mobility inside the city and street lighting but excluding the one created from buildings. Here we can input a maximum value of anthropogenic heat flux and create schedules for different days of the week separately depending on the flux of mobility or/and people. [39] Grass and tree coverage can be input simply as a decimal number from 0 to 1 to show the amount of coverage. Tree coverage is automatically calculated from the parameters if the trees are input as Context Shade. [39] The following figure shows the connection of all the above components:

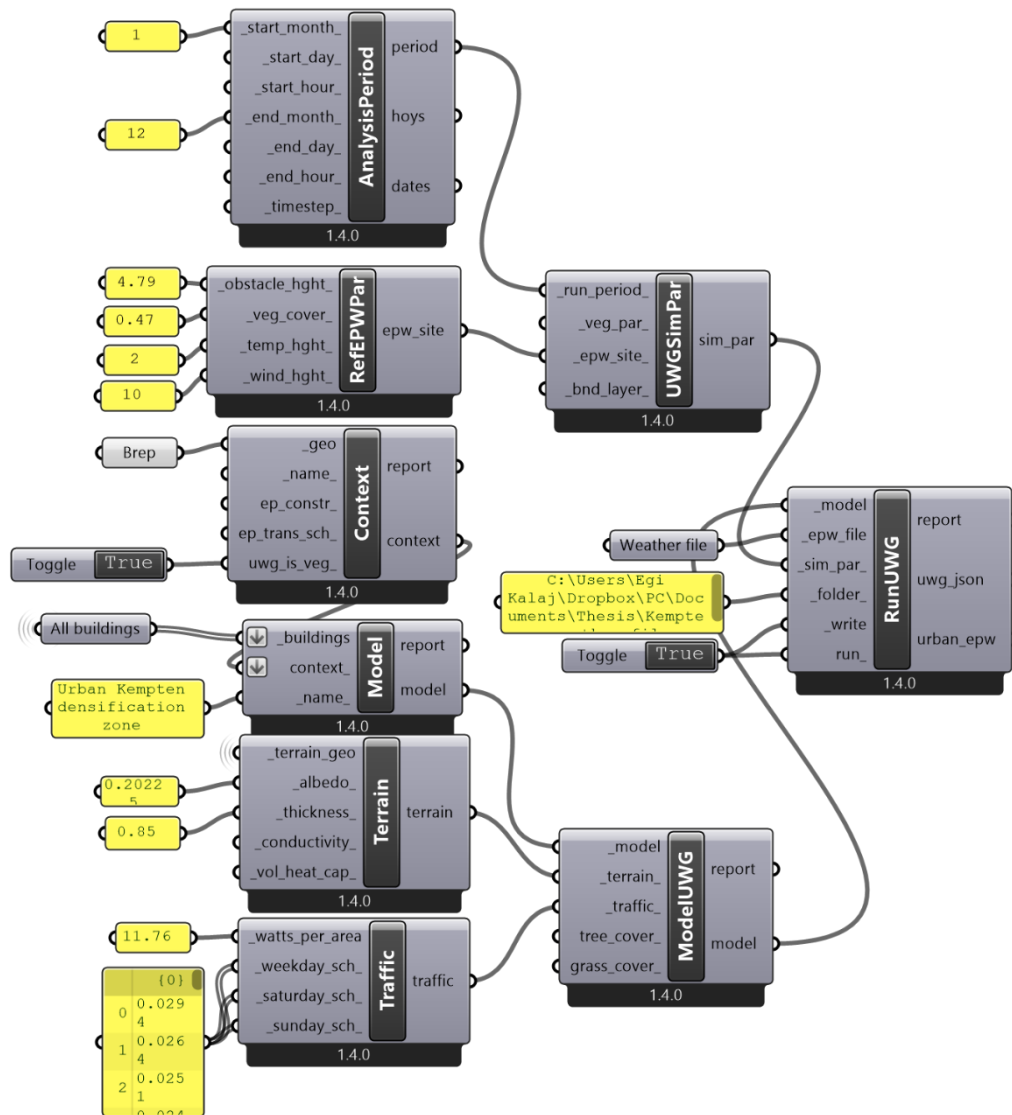

Figure 7 Component connection for the run of the UWG model

3.3.3. Calculation of Outdoor Surface Temperatures

The outdoor surface temperature is required in the phase of calculating Outdoor solar MRT. [57] In this thesis, we have input the buildings in a detailed process, that is why for the calculation of the outdoor surface temperatures, we do not use simplification such as the dry bulb temperature [57], which would then be an averaged temperature among all surfaces but we define for each one a specific temperature. To do this, we first run the Open Studio model, which has as one of the outputs internal/external surface temperatures [56]. The three parameters needed to run the component are: 1. HB model; 2. .epw weather file for the urban area; 3. Simulation parameters

These inputs appear to be similar to the ones needed for the run of the UWG model; however, they represent, in this case, different details. The difference will be further explained in this sub-chapter.

As the component “HB Model to OSM” only takes the HB model as a model, we first have to convert the model created in Dragonfly into HB [56]. This is done with the component “DF model to HB”. [39] With the “HB Deconstruct Model,” we separate the different parts of the buildings into rooms, openings, doors, etc. We consider the model separated into rooms in order to be able to use the component “HB custom Ground” to add the terrain geometry. From “HB Search Construction,” we find the asphalt and add it as a property to our added ground geometry. The last step before our Honeybee model is ready is “HB Solve Adjacencies” component, which is essential, for example, in order to avoid having the wall in between two rooms added twice in the model. The “HB model” component is then used to put all the rooms into one model. [56] The .epw file used in this case is not extracted from Meteonorm [58] but is the one generated for the urban area after running the UWG model.

The simulation parameters needed in this case are:

- The outputs we need from running the Open Studio Model
- Run period
- Time step (how many values per hour we would like to generate)
- The terrain where our area is (urban, suburban, city, etc.)
- Sizing parameters [56]

The “HB Simulation Outputs” component allows us to choose the outputs we receive after running the Open Studio model. In our case, we would select “surface temperatures,” but they are also other options possible such as HVAC energy use, zone energy use, etc. [56] The run period can either be for the whole year or a specific period [57]. Since we are interested only in the hot period in this thesis, we would run only for the hottest month. The component “HB sizing parameters” defines the size of the heating and cooling systems needed in the buildings. One of the inputs for this parameter is a .ddy file [56] which is a climate data collection utilized for sizing purposes [59]. This file can be generated from „LB Epw to Ddy” component and takes as input the urban .epw

[57] created in the previous chapters. To conclude, all these parameters can be used to run the Open Studio model component and receive as output from “HB Read face results” component the outdoor surface temperatures for each surface defined in our model. [56]

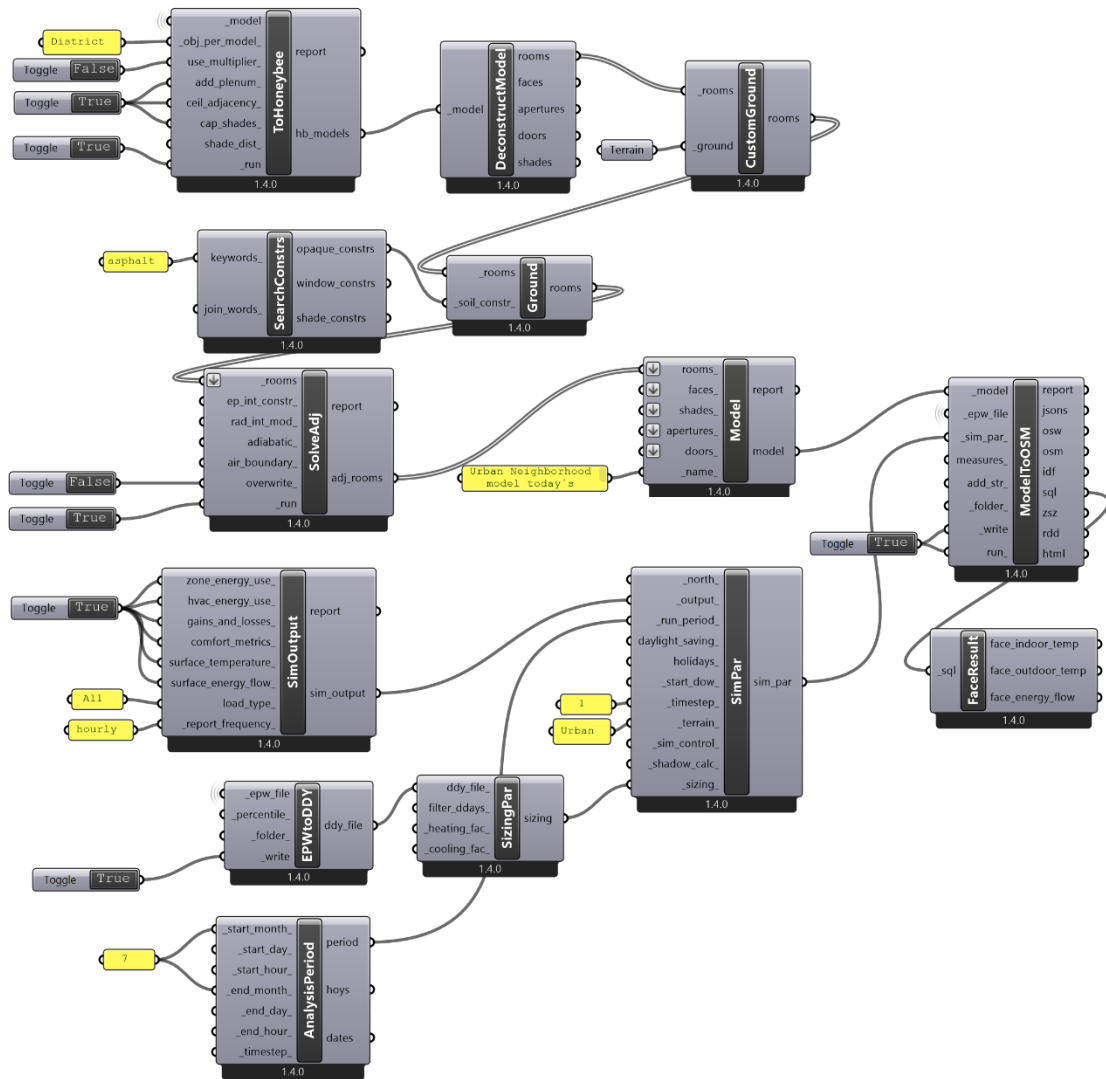

Figure 8 Parametric flow for the run of the OSM

It is important to note that the output of the outdoor surface temperatures is a list of surfaces with linked hourly temperature values [56]. We need to convert this into a list of hourly temperature values for each surface which is the input for the calculation of Outdoor MRT [57]. Therefore, we need a matrix conversion, and we use the essential components of Grasshopper. We now convert the new data list of outdoor surface temperatures in the same representation as other data lists, which will be input into the Outdoor Solar MRT[57]. Therefore, we use the components “LB Construct Header” first

to define a title and the type of data (temperature, HVAC energy use, etc.) for our new hourly collection and “LB Construct Data” [57] to create the collection as seen in figure nr.9. As a result, a collection of outdoor surface temperatures is created.

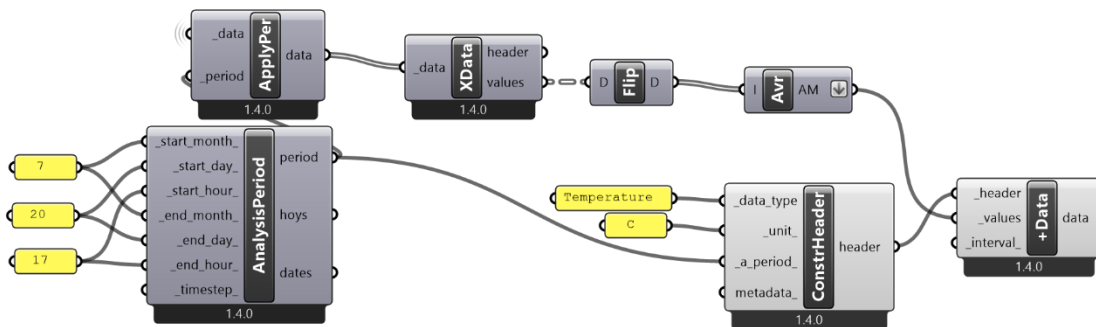

Figure 9 Preparation of an hourly data collection for outdoor surface temperature

3.3.4. Addition of trees in the urban area with PANDO

This part of the parametric flow is used exclusively in the vegetation scenarios. To add the trees in the urban area, we have used the tool PANDO. This tool requires the following inputs:

- The terrain where the trees will be located
- The central point of the tree position
- Crown shape (a choice between 6 different ones is possible)
- Tree species (a choice between 6 different ones is possible)
- Crown and trunk dimensions of the tree
- A tree library folder [52]

The trees created with this tool can be added to the component “DF ContextShade” as vegetation [39].

In order to verify whether the tree coverage area calculated from UWG when using PANDO is correct, a simplified version of an urban area was created. A terrain of 20x20m was chosen, and only one building (5x10m) and one tree (see figure nr.10) were added. It was noticed that when we input the trees created with this tool as geometry, the area of tree coverage calculated by the UWG is doubled; therefore, it is inaccurate. This issue happened because PANDO gives a bottom and a top part of the tree

crown, considering it twice as horizontal area when calculating tree coverage with the UWG [60]. Therefore, theoretically, for all the geometries created, the bottom area of the tree should be removed, and then the new geometry should be input as context shade. However, for this thesis, we accept this overestimation of vegetation coverage that UWG calculates when using Pando, and we consider it correct.

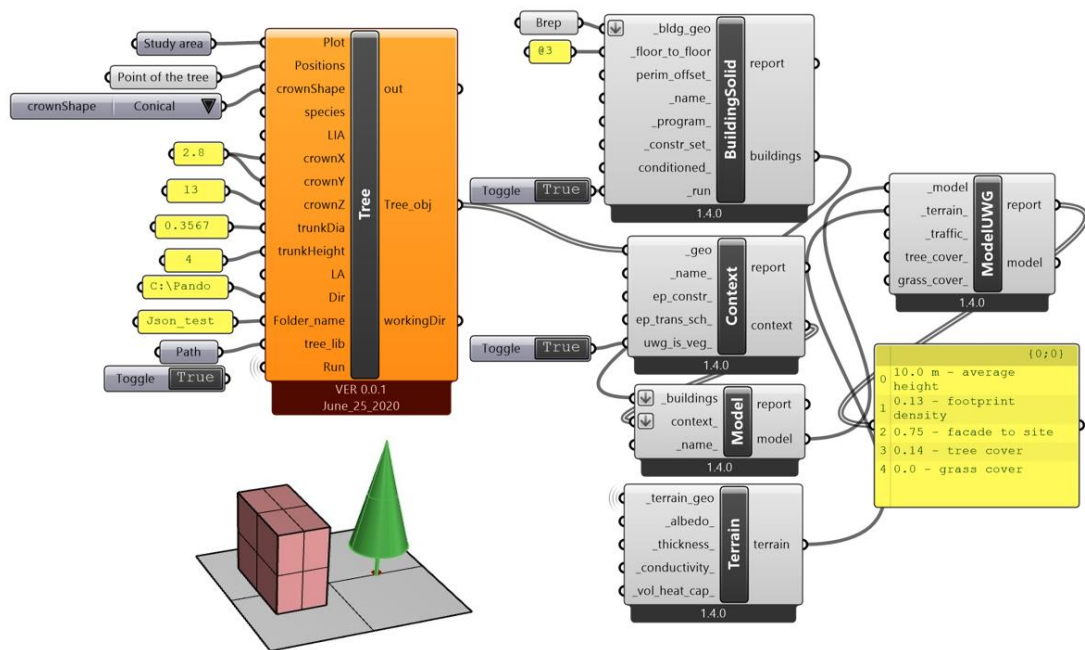

Figure 10 The use of Pando for the addition of trees for the UWG model in the simplified study area (lower left corner)

3.3.5. Calculation of UTCI for a specific point and all the urban area

This sub-chapter will show how to generate the values for MRT and UTCI, whether for a specific point of interest or the whole urban area under study. One of the most used components in this code phase is “LB Import Epw,” which gives some of the main parameters for calculating UTCI [57]. The weather file used in this case is the one generated from UWG for the urban area. The input parameters for the component “LB UTCI comfort” are: 1. Relative humidity; 2. Wind velocity; 3. Air temperature; 4. MRT; [57] The three first variables are extracted from the urban weather file created with UWG. A prerequisite for the calculation of UTCI is the calculation of the MRT, which in this case is conducted with the component “LB Outdoor Solar MRT”. [57] This component has as requirements the following parameters:

- Location of the study area

- Diffuse horizontal radiation
- Direct normal radiation
- Horizontal infrared radiation
- Surface temperatures
- Solar body parameters
- Ground reflectance
- Fracture body exposure
- Sky exposure [57]

The first four parameters are also part of the urban weather file. Depending on the study area, we can define different body and clothing characteristics with the “LB Solar Body Parameters” component. [57] Surface temperatures are taken from the run of the Open Studio Model [56] explained in subchapter 3.3.3. Ground reflectance can also be defined depending on the type of pavement in the area[57]. The last two parameters are calculated with the “LB human to sky exposure” component. This component allows us to study the relation to the sky exposure of humans in the positions given by us; therefore, it is essential to define the position of the human body and the geometries which can block the view of the sky. The positions, in this case, can be either a single point of interest or the whole urban area. In the case of the whole urban area, it is important to generate a mesh of points with a specified distance in between where the SVF and, later on, the UTCI (heat map) will be calculated. For this purpose, the component “LB Generate Point Grid” is used. [57] In the following figure, the connection between all the mentioned components in this chapter is shown:

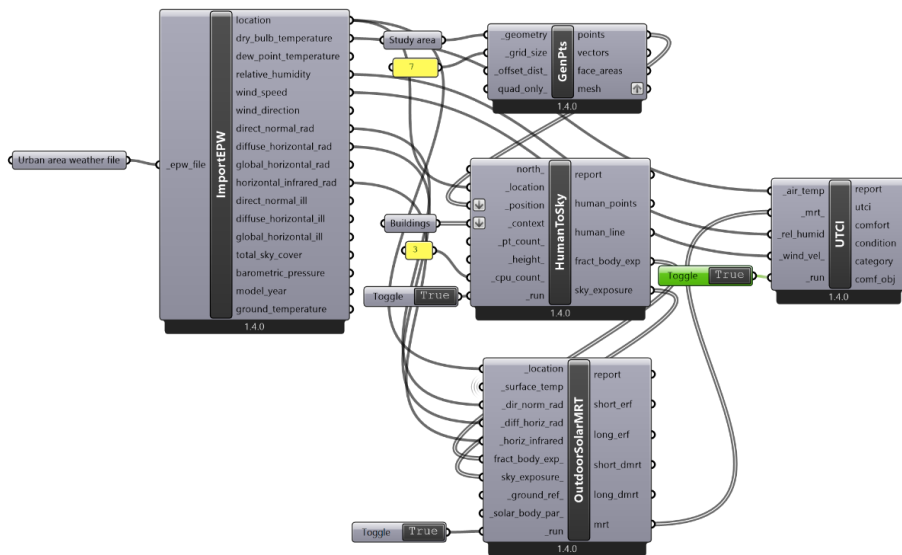

Figure 11 Parametric workflow for calculation of MRT and UTCI

3.3.6. Visualization workflow for the UTCI map and climate parameters

With the values found for the UTCI, we create a map throughout the urban area which shows the distribution of these values in the grid. For the heat map creation, we use the component “LB Spatial Heatmap” with the values from the UTCI component and the mesh created from the grid component also used for the UTCI. For changing the appearance of the heat map, the “LB Legend parameters” can be used to modify, for example, the colors used, the minimum and maximum values shown in the map, etc. [57]

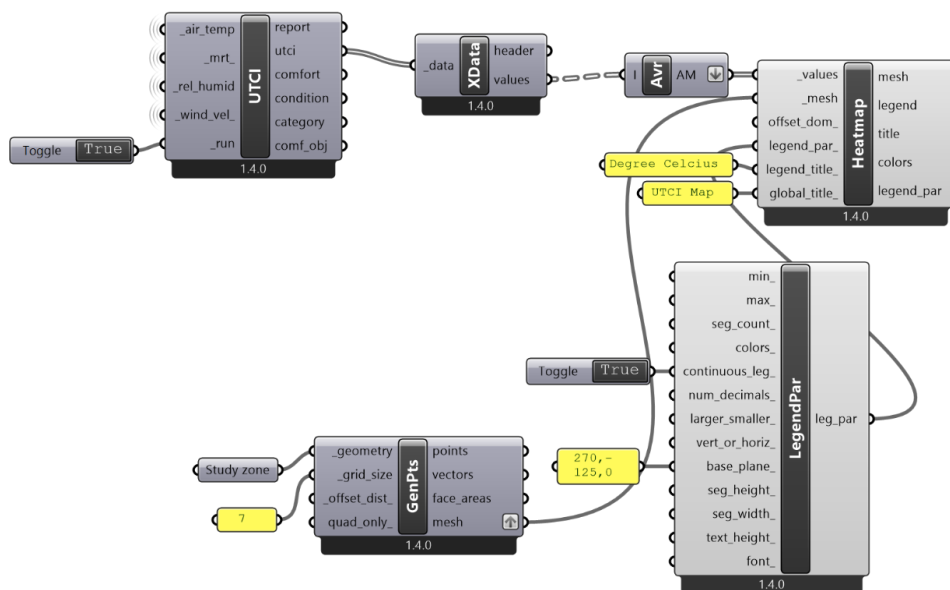

Figure 12 Heat map visualization parametric flow

For creating the climate condition visualization of the study area, some of the Ladybug components were used, which need data from the used weather file. These components are:

1. "LB wind rose"
2. "LB SunPath"
3. "LB psychrometric chart"

In order to show in a heat map the difference between the densification or/and vegetation scenarios for the case study, we make a difference between the UTCI data received for each different scenario using the component "Subtraction" [61] and with the new data we create a new heat map. This method is also used for the subtraction of other graphs. The followed path can be seen in the following figure:

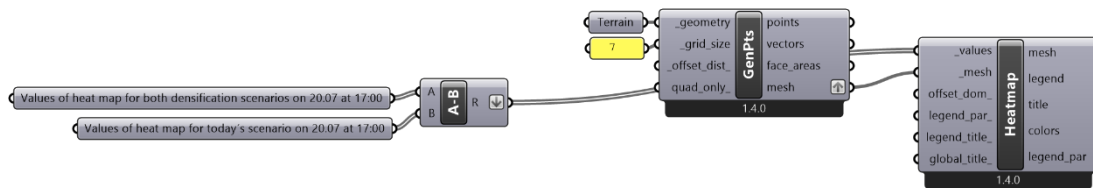

Figure 13 Difference between heat maps for two different scenarios

4. Case Study

In this chapter, the application of the parametric flow explained previously will be conducted in a case study. Initially, an overview of the location and characteristics of the climate in the study area will be defined. A detailed representation of all the scenarios studied for this area will be shown. The properties (building properties, glazing ratio, albedo, weather station, anthropogenic heat, etc.) specifically chosen for our study area which will be inputted in the parametric flow, and the reason behind this selection will be explained.

4.1. Study area

Our study area is located in the city of Kempten. Kempten is the largest city in Aellgau, a region in Bayern, Germany.



Figure 14 Location of the study area in Kempten, Germany [62]

The population of Kempten increased by 0.1% from 2019 to 2020, counting a number of 68.876 inhabitants showing an increasing trend that is expected to continue in the following years. [63] To understand the type of area we are planning our densification, we used the “Land use maps” provided by the city of Kempten. The chosen area can be seen in figure nr.15, and within it, we calculated the number of residential buildings and other types (figure nr.16). According to a simple calculation, by counting the number of different building typologies in the small area, we concluded that it represents 87% of residential buildings, making it suitable for adding new flats. [64]

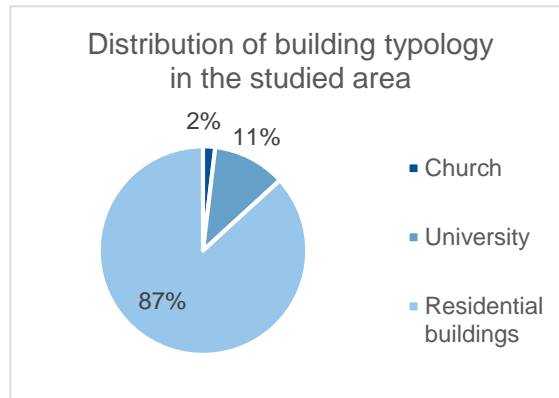

Figure 15 Area chosen for building typology check [64] Figure 16 Percentage of building typology

The five buildings under study are located in the southern part of the city at latitude/longitude 47.71673, 10.31327, reaching within walking distance the Central Station and also the park called “Haubenschloßanlage”. A bus stop is near the buildings, and the City hall and center are reachable in a 15 min walk. [65] Due to its strategic location, the area selected for this study is, therefore, suitable for densification and accommodation of new inhabitants with good connections to the rest of the city.

This research will study the effect on microclimate from two types of densification. In 5 existing buildings, we will calculate the addition of one more story in each of them, therefore vertical densification. While near the five buildings, a parking lot is located, which will be used to add two new hypothetical buildings as a way of horizontal densification. These new buildings could include underground parking to reduce the adverse effects on the neighborhood. The changes mentioned above can be seen in figure nr.17.

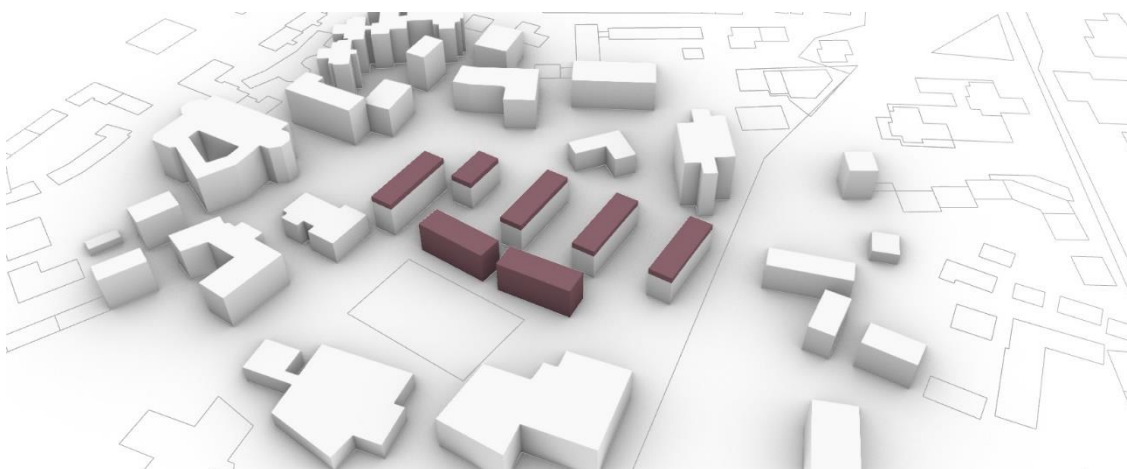

Figure 17 Rendered view of the hypothetical densification scenarios

One of the aims of these new densifications is to ensure enough living space for the increasing number of citizens in urban areas while also ensuring comfortable climate conditions and preservation and promotion of greenery between the buildings.

4.1.1. The climate in the study area

The city of Kempten is considered to have temperate climate conditions, with a high amount of precipitation which reaches around 1526 mm per year. [66] Relative humidity in Kempten falls in the range of medium to high humidity [67, p. 180], with the highest value reaching 82.65% in the month of November. [66] The average temperature in Kempten is 7.1°C, with the hottest and coldest months being July and February. [66] The hours of sunshine in Kempten reach around 2656.77 per year [66], which is considerably high compared to the average annual sun hours in Germany. [68] For the climate conditions taken from the weather file [58] at our weather station, we can calculate with the Ladybug tools [57] the sun path, wind direction, and the psychrometric chart. These graphs are shown in the following figures.

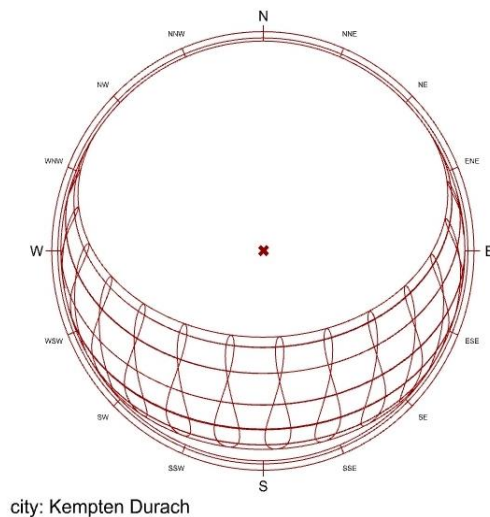

Figure 18 Sunpath for the weather station in Kempten

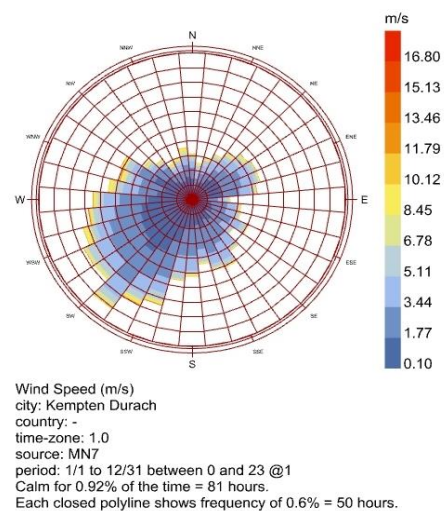

Figure 19 Wind rose for the weather station in Kempten

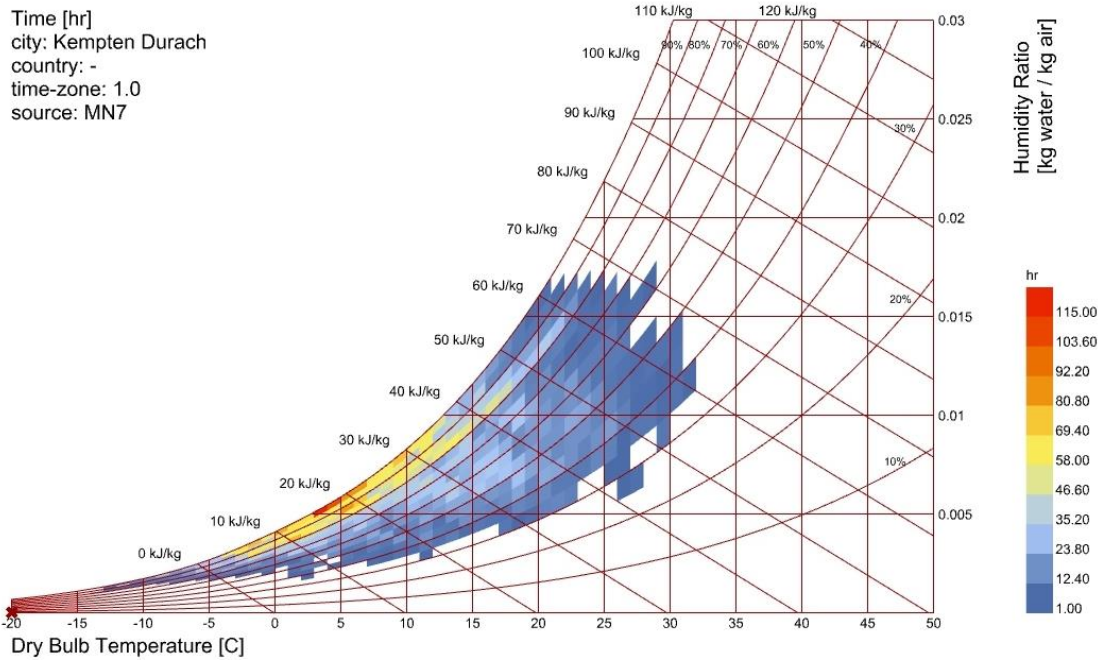

Figure 20 Psychrometric chart for the weather station

4.2. Scenarios considered for the case study

For this case study, we consider six different scenarios:

1. The current building situation in the study area (scenario 1)
2. Vertical densification scenario (addition of one floor in 5 existing buildings) (Scenario 2)
3. Horizontal densification scenario (addition of two new buildings) (Scenario 3)
4. Both densification scenarios (combination of the vertical and horizontal densification) (Scenario 4)
5. Today's scenario with vegetation on the current status quo (Scenario 5A)
6. Both densifications with vegetation scenario (% of vegetation added) (Scenario 5B)

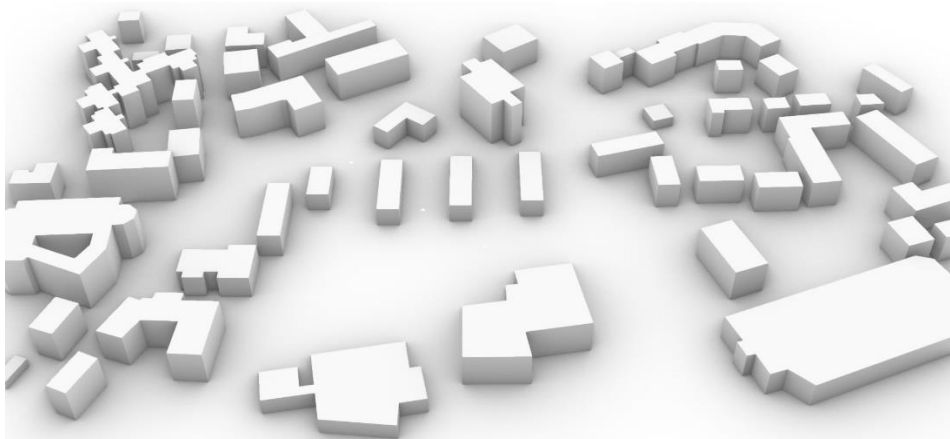

Figure 21 Today's scenario of the area (current building conditions without vegetation) (scenario 1)

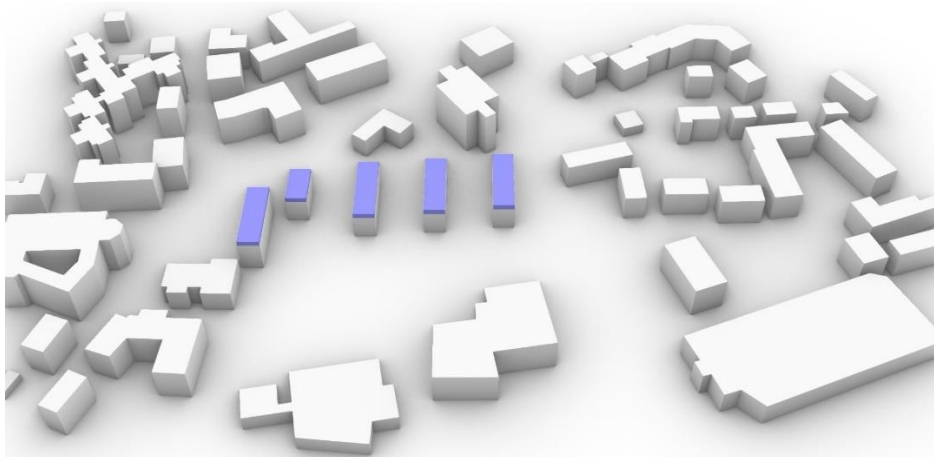

Figure 22 Vertical densification scenario (addition of one floor in 5 buildings) (scenario 2)

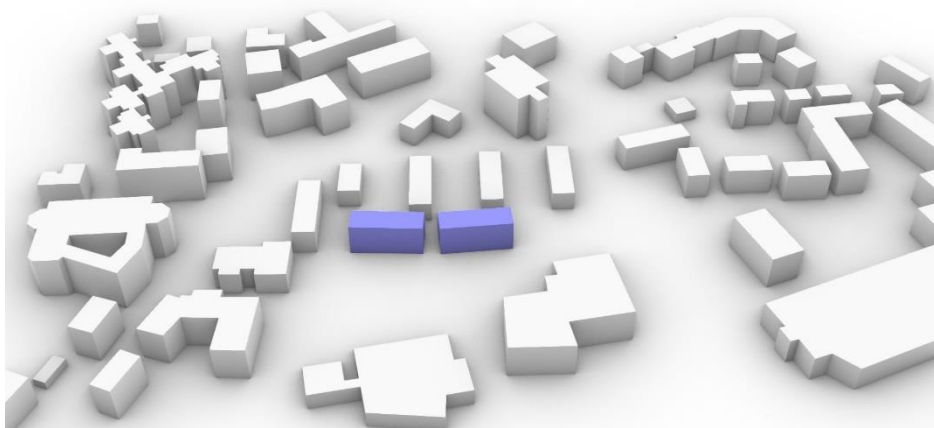

Figure 23 Horizontal densification scenario (addition of two new buildings) (scenario 3)

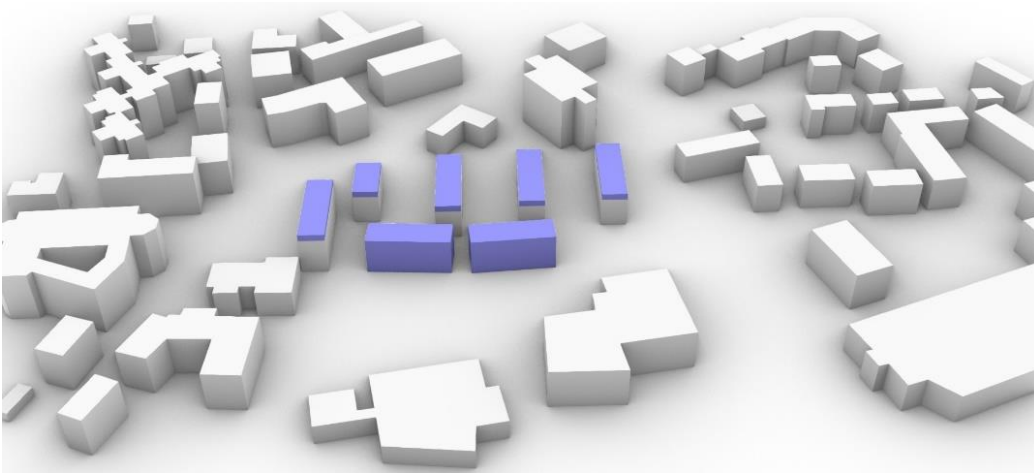

Figure 24 Both densifications scenario (combination of the vertical and horizontal) (scenario 4)



Figure 25 Today's scenario with the addition of trees in the current status quo (scenario 5A)

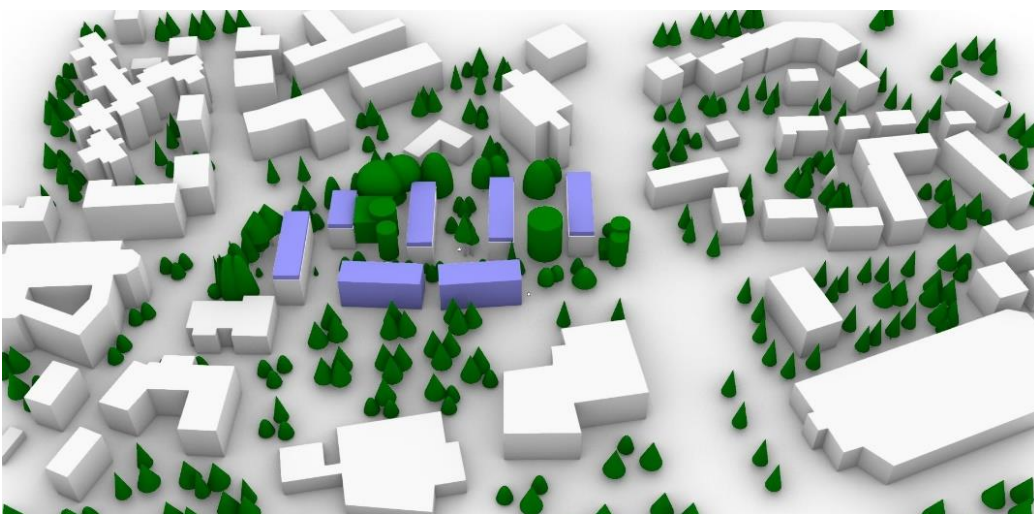

Figure 26 Both densification with addition of 30% tree coverage scenario (scenario 5B)

4.3. The input of buildings characteristics for studied buildings

This chapter introduces the physical characteristics of the buildings in the studied area. Buildings in this thesis are named and grouped depending on their different properties. We make a division into six categories for the base scenario, and 7 for the scenario with horizontal densification or both densifications included. In the simulations, these buildings are named:

1. Five-story building under densification
2. One building under densification
3. Three buildings under densification
4. Two new horizontal densification buildings
5. Surrounding buildings
6. Church
7. University of applied sciences

This division is made considering the different building heights, glazing ratios, or programs of each building. The buildings studied for densification are the first four categories. Meanwhile, the rest of the categories are buildings near the area we are studying for which we do not know in detail the floor-to-floor height or glazing ratio but are an essential input for calculating the effect of building density of the area in the UHI effect.

4.3.1. Building height

Building heights in the studied area vary as we have different building typologies, not only residential ones. For the five studied buildings, which will have vertical densification, we have available the construction file (see Appendix A); therefore, we can add a precise number for the building and floor-to-floor height. For the three first categories of the buildings, floor-to-floor height is taken from the construction documents and is put together in the following table:

Table 2 Floor-to-floor height of the buildings under study (Appendix A)

	Story height					
Building	1st	2nd	3rd	4rth	Attic	Sum
Five-story building under densification	2.625	2.625	2.625	2.65	1.5	12.025
One building under densification	2.625	2.625	2.65		1.5	9.4
Three buildings under densification	2.625	2.625	2.65		1.625	9.525

For the vertical densification in these buildings, we have assumed the addition of one floor, which we chose to increase by 2.625 as it appears to be the most common floor height (see Appendix A). The calculation of the building's height after the addition of the floor is shown in the following table:

Table 3 Floor-to-floor height after vertical densification (Appendix A)

	Story height						
Building	1st	2nd	3rd	4rth	5th	Attic	Sum
Five-story building under densification	2.625	2.625	2.625	2.65	2.625	1.5	14.65
One building under densification	2.625	2.625	2.65		2.625	1.5	12.025
Three buildings under densification	2.625	2.625	2.65		2.625	1.625	12.15

For the surrounding buildings, for which we do not know the exact height of the floors, we consider that in Bayern, the minimum clear height of a floor is 2.4 m. Clear height is the height from the upper part of the floor to the lower side of the ceiling. [69] In this case, we accept a height slightly higher than the minimum for our study, so 2.5m. According to TABULA, a web tool that collects residential building data, the multi-family houses built in Germany from 1949-1957 have mostly concrete ceilings [70]. According to DIN EN 1520, concrete ceilings have specific widths from 33 to 62.5 cm [71]. For this study, we use 50 cm. As a result, the floor-to-floor height we input into our model will be 3m. When it comes to the floor-to-floor height of the church, as input, we put the full height of the church since a church is not divided into floors. For the University, we have chosen a height of 4 m (bigger than for the residential buildings) in order to provide more

daylight inside the spaces and more flexibility, including auditoriums and seminar classes. The total height of these buildings has been roughly calculated using the visible number of floors on Google Earth [72].

4.3.2. Building's glazing ratio and SHGC values

When considering the five buildings under vertical densification, a detailed representation of the fenestration of the façade is possible. A detailed calculation of the glazing ratio in each direction was conducted. This calculation was done following the formula:

$$WWR (\%) = \frac{\sum \text{Glazing area (m}^2\text{)}}{\sum \text{Gross exterior wall area (m}^2\text{)}} [73]$$

The data for this calculation was taken from the existing floor plans in Appendix A. The result of the glazing ratio in different directions is shown in Table nr.4:

Table 4 Glazing ratio of the five buildings under study (Appendix A)

Glazing ratio	North	East	South	West
Five-story building under densification	0.1264	0.2532	0.1243	0.2014
One building under densification	0.0454	0.2382	0.0993	0.1655
Three buildings under densification	0.0897	0.228	0.119	0.1322

After the addition of one floor, a slight difference is noticed in these building's glazing ratio, as shown in the table below:

Table 5 Glazing ratio of the five buildings under study after the addition of one floor (Appendix A)

Glazing ratio after densification	North	East	South	West
Five-story building under densification	0.128	0.259	0.127	0.2056
One building under densification	0.0466	0.244	0.1028	0.1722
Three buildings under densification	0.0908	0.2243	0.123	0.1295

For these buildings, we can also define the height of the windows, the sill, and the distance between the windows. The distance between windows is given in an approximated way, as different distances are in different parts of the buildings, which is impossible to input in the DF components. These values were extracted from Appendix A and can be seen in Table nr.6.

Table 6 Further detailed parameters of fenestration for the buildings under study (Appendix A)

	5 Buildings under study
Window height	1.26
Sill height	0.875

Since for window ratios over 30%, appropriate treatments for shading have to be taken into consideration [74], and as we know, the other buildings in the area vary from 0.13 to 0.176, so we choose a value of 0.175 hypothetically for the glazing ratio in the surrounding buildings. For administrative and Office buildings in Germany, it is recommended to stay below the 30% glazing ratio [75]. Considering that this is the most similar building typology we have found, we also maintain the glazing ratio of 30% for the University in Kempten. Concerning the church, exact calculations of the glazing ratio and neither floor plans of the church were found; that is why an estimation was made by comparing the façade of the church (see figure nr.27) to other studies.



Figure 27 Church of St. Anton, Kempten, Germany [76]

As it can be seen in figure nr. 27, the glazing ratio of the church does not cover a high percentage of the façade. In a study of the church Sant Louis in Sevilla, it was noticed that the glazing ratio does not exceed the value of 10% [77]. Considering these two facts, we have approximated the glazing ratio for the church to be 10%. For the two new horizontal densification buildings, the ratio is calculated by the average of the five existing buildings assuming a similar building typology, so we have chosen 17.5%.

Lastly, as a simplification, we assume the same SHGC for all buildings discussed in this study. Therefore, we consider the most common construction year range 1949-1957, and from Tabula, we check what window type was the most commonly used one in Germany in those years. According to Tabula, for normal refurbishment, the used windows are double glazed with a low-E coating and Argon gas, which has a U-value of 1.3

W/(m²K). [70] For this specific U-value, we find the corresponding SHGC value, which is 0.65 [78, p. 52].

4.3.3. Building age

One of the characteristics to input in the building parameters is also the building age. The Ladybug tools provide different periods of building ages; depending on when our buildings were constructed, we apply for each of them the corresponding period.

The five buildings under study, which will experience vertical densification, have building years 1949-1959 (see Appendix A) which falls under the category "Pre_1980". Information about the surrounding buildings is not available; that is why in this case, we assume the same building period. The church in the study area was built on 1836 [79] and therefore remains in the same category as the previous buildings.

The University of Applied Sciences Kempten has existed since before 1980, but the teaching, due to the low number of students, was held in rented rooms and not in an actual building. In 1980, a plot of 42.000m² was assigned for the university, so in the simulations, the building vintage is considered to be "1980_present". [80] For the buildings which will be added as a result of horizontal densification, the building vintage is added as "New".

4.3.4. Building's construction set

For the decision of the construction set, there are a few parameters that have to be considered. Firstly, the type of building, whether it is mass, steel, wood construction, etc., has to be defined. Secondly, the age of the different buildings and the climate zone in which our area falls are to be defined. The climate zones provided in the Honeybee component [56] vary from very hot to subarctic, and considering the climate in Germany, we input climate zone 5, which shows a cool climate. For the studied buildings, we can see in (Appendix A) that they are made out of mass. For the surrounding buildings, since we assume building years from 1949 to 1957, we take from Tabula that multi-family houses of that period are primarily solid constructions out of brick walls [70]. For the church and University, we also accept mass construction as well as for the two new buildings since we consider the same construction as for the existing ones. Overall, in between these building constructions are all considered mass construction, and in climate zone 5, the difference remains in the build year defined for each building.

4.3.5. Building's programs

The Honeybee tools provide a list of several building programs we can assign to our studied buildings, which is essential in order to assign different spaces when it comes to the run of the Energy simulation. However, not all types of buildings are included yet in this list of programs, which is the reason that for some of them, we have to approximate the most related type of program. [56]

When considering the five buildings under vertical densification or the surrounding buildings, HB provides the program for residential buildings with a difference between High-rise and Midrise buildings. Due to the low number of floors in our study area for all these buildings, we input the program as "Midrise Apartment." However, depending on the specific cases, we must differentiate between the different build years. Moreover, when it comes to the Church, no building program gives the reference to such a building, which is why we approximate the closest possible, in this case, a "Warehouse". A similar situation occurs with the University of the Applied Sciences, but in this case, the approximation is more relevant as there is a building program for a "Secondary School" available. [56]

4.3.6. Albedo and thickness of terrain

For the scope of this thesis, in the first four scenarios, we do not consider grass or vegetation, and we assume that all the area uncovered by buildings is asphalt. In order to be able to run the UWG, we have to input some terrain information like the geometry, albedo, and thickness of terrain, in this case, asphalt [39].

In a study conducted for asphalt pavements, where four different construction years for the new layer of asphalt were considered (respectively 2008, 2007, 2014, 2013), different albedo values were conducted (see table nr.7) [81, p. 172] Considering the fact that no information for the year of construction of the asphalt in our area is known and assuming that improvements have been made continuously in different years, we take the average of these values and use 0.20225 for the albedo value.

Table 7 Asphalt albedo for different years of construction [81, p. 173]

	AC1	AC2		AC3
		Sections 1–5	New AC overlay	
Albedo	0.2266	0.2338	0.1214	0.2272

Furthermore, for the thickness of the asphalt pavement, we take the value of 85 cm. We consider the same cross-section for the asphalt construction used in the same study where the albedo values were dragged from [81, p. 172]. The used model can be seen in figure nr. 28.

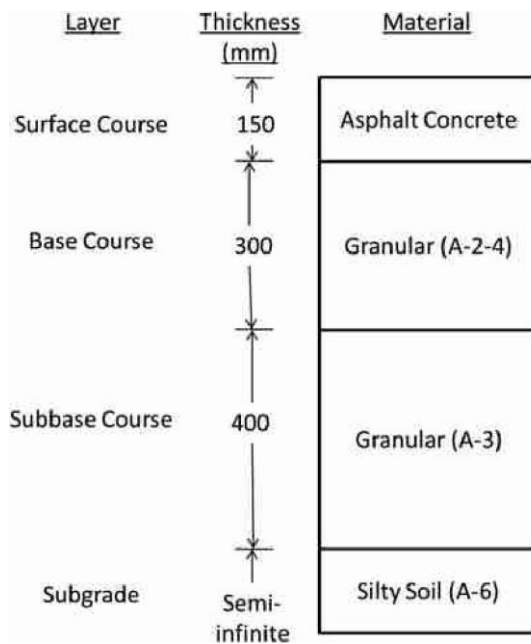

Figure 28: Asphalt construction model [81, p. 172]

4.3.7. The albedo of walls and roof for each building

The roof albedo for all the buildings in the study area is simplified in the following table nr.8:

Table 8 Albedo values for the building roofs in the study area used for the parametric flow

Buildings	Roof Albedo Value
5 Buildings under study	0.3
Surrounding buildings	0.26
Church	0.26
University of Applied Sciences	0.3

The differently chosen values are explained briefly in the following sentences. Appendix A shows that the roof construction in the five existing buildings is realized with pre-stressed concrete. Due to this, we have chosen a roof albedo for a gray composition of value 0.3 [82, p. 130] to assimilate the color of the concrete roof in the buildings. The exact value was also chosen for the University in Kempten. In this case, information about the roof construction was not found, but a screenshot was taken from Google

Earth [72] to understand the color, and it is also in the shades of grey as the five buildings under study (see figure nr.29).



Figure 29 View to demonstrate the roof color of the buildings in the study area [72]

Regarding the Church and the Surrounding buildings, the highest number of them appear to have red clay roofs, as can also be seen in figure nr.29. That is why from a study where they calculate albedo values for different types of surfaces, we extract the value of albedo for red clay mission tiles for roof constructions which is defined as 0.26 [83]. As a second step, the decision of albedo values for the walls in our study area has to be implemented. Table nr. 9 shows an overview of the chosen values:

Table 9 Wall albedo values for the buildings in the study area

Buildings	Wall Albedo Value
5 Buildings under study	0.46
Surrounding buildings	0.33
Church	0.33
University of Applied Sciences	0.2

For the five existing buildings, we can see in Appendix A that the outer walls are constructed with Pumice blocks. Pumice is a rock created during volcanic explosions with very light density and color, often used for building due to its properties and cheap price [84]. One of the ways to use Pumice in construction is by making blocks or tiles of pumice-concrete. [84] Knowing the construction material of the outer walls and also the color of the buildings, we find the closest combination for the albedo value of the wall.

For this purpose, a study where three differently textured concrete prototypes, while applying different colors on them, were taken under consideration. The chosen color for our study was ivory, which appears to be the most relevant compared to the buildings in the area. [85, p. 157] Since the pumice blocks do not have a similar texture to any of the textures used in this study, an average of the three used textures for the ivory color was considered while also considering aging of 3 years for the paint of the walls because the walls do not seem to be freshly painted. [85, p. 157] All these added up to the value of 0.46.

There is no detailed information on what materials were used for the walls of the other buildings surrounding our study area. Therefore, in this case, the relevant information for the albedo approximation remains the color of the façade. After an investigation on Google Earth [72], the majority of the building, including the church, appears to have a creamy color. The albedo value was then taken from a study where the thermal performance of buildings was studied depending on landscape parameters in which walls with cream color were assigned an albedo of 0.3 [86]. The same approach was used for the University in Kempten, where it was noted that the walls are in a dark grey tone. Considering it as a dark-colored wall, the albedo value is defined as 0.2 [87, p. 6].

4.4. Calculation of parameters for the weather station area

They are four values that we need to input for the weather station area: the obstacle height in the location, which can be trees or buildings, the vegetation coverage, and the height where the wind speed and temperature are measured. [88]

In our case study, the weather station is not located, as commonly used, close to an airport [34] but rather inside the urban area. The difference in this case to usual weather stations located in airports is the obstacle height, which is higher, as the obstacle is not only grass but also buildings. The Dragonfly component gives a default value of 0.1m obstacle height. [88] The infra3D website was used for the rough calculation of buildings' height in the weather station in Kempten, which was chosen as 4.79m. [89] However, an error should be considered for the obstacle height in this case as a random building was selected as representative, and it was not an interpolation between different obstacles.

It is to be mentioned that this triggered an issue with the old versions of the ladybug tools as the component would not allow input values similar to the height of the buildings in the urban area for the obstacle height parameter in the weather station. In LB tools 1.3.0, the Urban weather generator fails to run with an obstacle height of 4.79. However, this error was debugged with the new version of the ladybug tools (1.4.0), and it is now possible to input a higher number for the obstacle height at the weather station. [90] Therefore, version 1.4.0 is used throughout this thesis.

The height of wind and temperature calculation is taken from the weather files exported from Meteornorm, a website from which reliable weather data can be extracted from different years for different sites. In our case, the wind is measured at the height of 10m while the temperature is at 2m. [58] The weather station location in Kempten is shown in figure nr.30.

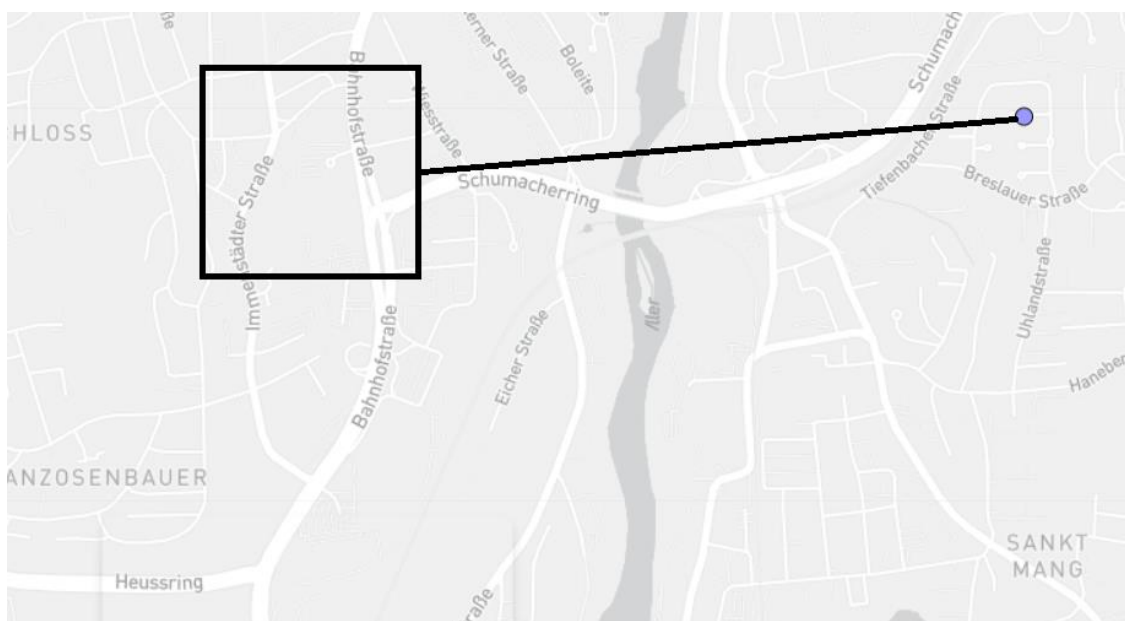

Figure 30 The location of the weather station (blue dot) compared to the study area (rectangle) [58]

The last parameter to calculate is the vegetation coverage in the area. The calculation of this parameter, for this thesis, is a simplification compared to the accuracy of other programs like, for example, ArcGIS [91]. The Dragonfly tools for creating the UWG were used again for calculating the vegetation parameters [39]. A snapshot of the weather station area was taken from Google Earth [72] and input into Rhinoceros as a base layer. The buildings were created by simple surface geometries and extruded while the vegetation was left as surfaces. The building heights are simplified to one value (4.79),

the whole vegetation is input as trees, and no division from grass is made (see figure nr.31).

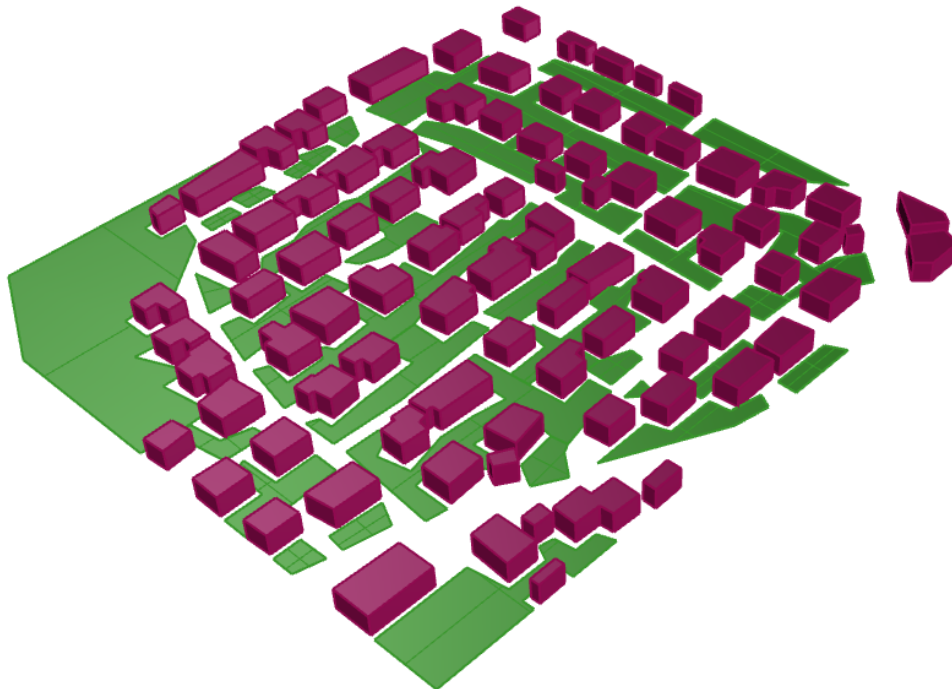

Figure 31 Input of geometries for buildings and vegetation in Rhinoceros

Into the “DF model” component, you can input context shade which can either be surrounding buildings in the study area or vegetation surfaces [39]. To show that the surfaces should be considered as vegetation, we add a set to true Boolean toggle to the last part of the component. The “DF ContextShade” and “DF buildings” are input then to the “DF model” and later on, “DF Assign UWG Properties” from where we can get the output of our weather station vegetation coverage. [39] As shown in figure nr.32 for our weather station, this coverage is 47%.

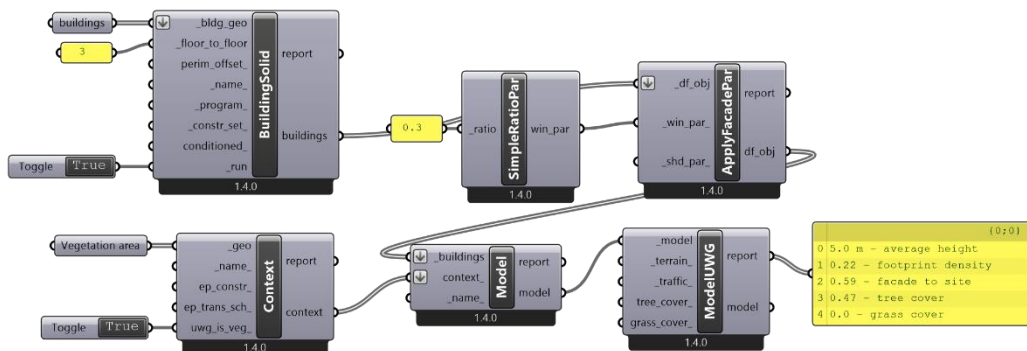

Figure 32 Calculation of vegetation coverage in the weather station area

4.5. Anthropogenic heat for the urban area in Kempten

The UWG also requires traffic parameters for the urban area, which means the average anthropogenic heat and hourly schedules for the weekdays and weekends. Anthropogenic heat in a city or neighborhood depends on the population density and the climate. [92, p. 8] To calculate anthropogenic heat, we consider the waste heat which comes from the building sector, the vehicles, and the human metabolism. [92, p. 10] A study held in the US for cities with different densities and climates created hourly profiles for different months of anthropogenic heat. This study, however, does not make a difference between weekdays and weekends. [92, p. 12]

In Dragonfly, the component “DF traffic parameters” takes as input the value of anthropogenic heat in W/m^2 and gives four default values for the maximum anthropogenic heat depending on whether the studied area is commercial, residential, downtown, etc. The default input value in the daily schedules, however, is only for a commercial area. [93] In this study, the area contains mainly residential buildings.

That is why we ran the UWG twice, with different anthropogenic heat values, to understand how UTCI values for a particular point of the urban area differ when considering different values for the anthropogenic heat. Firstly, with the default values of the component for anthropogenic heat of $10 W/m^2$ (commercial area in Singapore) [93] and secondly, with values of anthropogenic heat and schedules from the study in the United States [92] for a city with a similar density to Kempten. The city chosen from the paper is Toledo, Ohio, which has a population density of 1.278 per km^2 (3.311 per sq mile)

[94], with a slight difference from Kempten, with a population density of 1.089 per km² [95]. From the schedules prepared for Toledo, we chose the hottest month to take the data from (July).

The first scenario calculated was the one with the program's default values for a commercial area [93], and the UTCI in the point studied resulted in 33.836438. The second scenario was with the values from the city of Toledo for both the hourly schedule (see table nr.10) and the max anthropogenic heat of 11.76 [92]. The resulted UTCI is a value of 33.836412. The difference between these two scenarios is 0.000026, a relatively small difference that we can ignore. This trial was conducted to understand if the anthropogenic heat of specific areas significantly affects the final result of the UTCI. However, since we saw that for two different scenarios, the change is minimal, we do not calculate specifically for the area of Kempten but instead take the values for the city of Toledo, which are also provided in table nr.10.

Table 10 Hourly Anthropogenic heat for the city of Toledo in July [92]

Hours	0	1	2	3	4	5	6	7	8	9	10	11
W/m²	2.94	2.64	2.51	2.45	2.60	3.47	6.22	9.65	10.33	9.43	9.46	9.94
Hours	12	13	14	15	16	17	18	19	20	21	22	23
W/m²	10.55	10.53	11.04	11.84	10.65	9.27	6.62	5.65	5.14	4.80	4.27	3.57

4.6. Grass coverage and addition of tree parameters for today's scenario

As mentioned in this thesis, grass and tree coverage will be considered only for the vegetation scenarios. For today's scenario, only the status quo of the vegetation will be included. In contrast, trees will be added for scenario 5B to calculate their effect on outdoor comfort. No detailed information on the grass coverage of the study area is available; that is why we have used the grasshopper plug-ins to estimate this value. The same parametric flow mentioned for the weather station site (see chapter 4.4) was also used in this case. As a result, we got a value of grass coverage for our urban area of 0.17. However, it should be mentioned that this is an estimate and not the actual value of the grass coverage, as often it is not possible from the google earth [72] picture (see figure nr.33) to separate grass from trees.

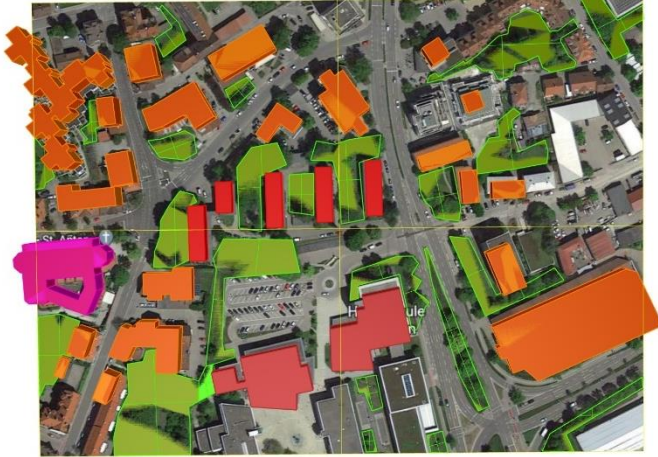

Figure 33 The captured picture to calculate the grass coverage in the urban area (based on Google Earth [72])

For the trees in the urban area, we have detailed information on the species and the dimensions of the crown and trunk for the part of the area close to the densified buildings (see Appendix B). For these trees, we give detailed information on the size and dimensions required for Pando [53]. However, when it comes to the shape, we make an approximation depending on the species and whether it has one of the six shapes used in Pando [53]. Furthermore, the proportion between trunk height and crown height is also approximated as the knowledge we have is only the full height of the tree (Appendix B). For the rest of the trees for which we do not have a detailed information table, we chose the most typical species we had noticed in the rest of the area, which is “Fichte” (fir tree). For the dimensions, we averaged the ones from the other trees with the same species, including “Serbische Fichte” and “Fichte”. The dimensions concluded for the rest of the trees can be seen in table nr. 11. (Calculations were conducted with the help of Appendix B). To define the position of the missing trees, a picture was extracted from Google Earth [72], and the center of the tree was approximated according to it. Therefore, an error should be considered in this case.

Table 11 Information concerning added trees (Appendix B)

Crown shape	Conical
Crown diameter	5.6m
Crown height	13m
Trunk diameter	0.3567m
Trunk height	4m

4.7. Grass coverage and tree addition for Scenario 5B

For the grass coverage calculation, in this case, we have to remove the grass in the area where we build the two new buildings. The same methodology for the calculation as in the previous chapter is also used in this case. After the re-calculation, the grass coverage for this scenario was slightly reduced to 0.16. From an inspection through Google Earth [72], we noticed that the area where the two new buildings are added is mainly covered in asphalt.

However, when it comes to the trees which will be considered in this scenario, we first notice that a minimum of two from the existing trees will have to be removed for the building process (see figure nr.34) as they are directly on the position where the new buildings are. It should be mentioned that a more significant number of trees would probably be removed for an actual construction site, but for this thesis, we simplify and assume that the rest can be kept.

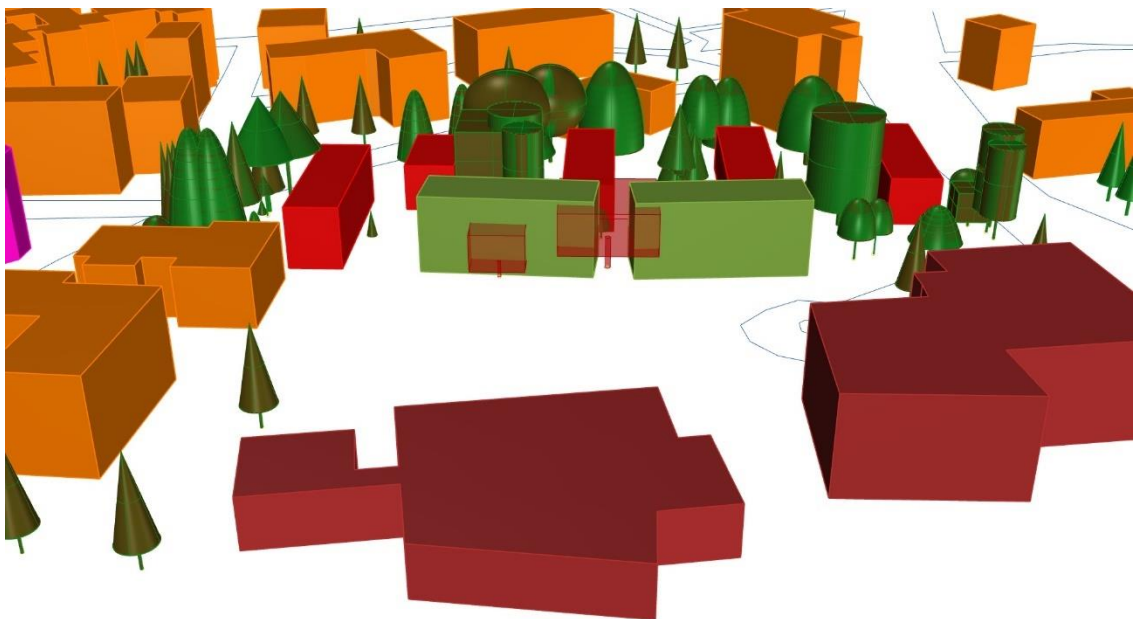

Figure 34 Position of the two trees which interfere with the two planned buildings

The purpose of this scenario is to check whether the trees can help the microclimate effect; therefore, it is important to understand a method for further addition of trees in the urban area. In a study in Munich, Germany, it was concluded that the best positioning of the trees when we talk about the urban area is in the thermal hotspots of the area and instead in groups than in single tree placements [30, p. 3, 31]. Furthermore, a study kept in Canadian cities enforces the previous statement by showing that the placement of trees in areas where there is currently a lack of shade and using large tree canopies

brings better results in improving outdoor comfort. [31] The addition of the new trees can be in parking lots, inner courtyards, or pedestrian sidewalks in the urban area. [96, p. 307] The tree placement must be put at a certain distance depending on the crown diameter [31]. Another critical parameter to consider is the minimum distance the trees can have to the building, which is 3m due to damages that the root growth can cause to the building. [97, p. 10] Therefore, each of the newly added trees in this scenario will apply this minimum distance. Depending on the tree's position, three different crown sizes can be used for addition in the urban area: small, medium, and large, even though the possibility of adding large and medium trees in areas with residential buildings is lower [98, p. 68]. In this case, we will simplify using only two types of trees that appear to be present most often in the study area (according to Appendix B). As the two representatives, they were chosen the trees: "Fichte" and "Kiefer". Both these trees seem to differ in height; that is why we choose two types to represent different heights and different shading patterns. The details chosen for each of them are shown in the table below.

Table 12 Details for the newly added trees (Appendix B)

Name of tree	Trunk diameter (cm)	Crown diameter (m)	Height of the tree (m)
Fichte/Serbische Fichte	115	16	8
Kiefer	70	8	6

According to a study conducted in Munich, the comfort of pedestrians after densification, reaches today's values or lower for a rise in tree coverage from 7% to 22% or 34% in the urban area. [96, p. 312] Another study held in Phoenix, Arizona, where there is a 10% tree coverage, showed that the predicted increase in temperature due to climate change could be equalized with an increase of this coverage to 25% [99, p. 183]. Therefore, considering these studies, we chose an increase from 10% to 30% of the tree coverage for our case study. The final scenario (scenario 5B) will include a tree coverage of 30%.

5. Results and discussion

In the following chapter, results from comparing the different scenarios will be identified. The microclimate analysis will be held in three stages: air temperature, MRT, and UTCI. Firstly, the difference in air temperatures between the weather station and “Today’s Scenario” will be shown, and later on, the difference in air temperature between the status quo and each densification scenario. Furthermore, the difference in MRT and UTCI between all scenarios will be shown with the help of the spatial heat maps and the decision of 4 study points. Lastly, the results will be compared to previous studies with the same or similar content.

5.1. The decision of the representative hour for further calculations

In order to understand the impact of urban densification on the outside air comfort, in this thesis, we have chosen to represent our results for the hottest hour of the year to represent the difference in temperature between different scenarios. To calculate the hottest hour of the year, we firstly ran a search from the .stat file with the component “LB_Import STAT” [57], where we can extract the extreme hot week of the year, which in this case appears to be from 20-26 of July. In figure nr.36, we can see that the average dry bulb temperature is the highest in July. However, this extreme hot week does not represent the hottest hour of the year regarding the dry bulb temperature. A check on the new urban weather files shows that the hottest hour falls on the 1st of August at 16:00 with a value of 31.2°C. The above-mentioned case calculates the dry bulb temperature, which does not account for moisture or radiation in the air [100]; that is why we also calculate the UTCI to see whether it falls under the same hour. Firstly, we simulate only one point, which is chosen randomly in between the studied buildings (see figure nr.35). For the specified point, the simulation is firstly run for the whole year (1.1-31.12), and we see from the results that the hottest hour falls in July. This is represented by the 473rd hour of the month. This hour corresponds to the 20th day of the month at 17:00. So, as we see, the dry bulb temperature and the UTCI give us a different date for the hottest hour. To represent our results in the heat maps, we will use the hottest hour for UTCI since we are interested in outdoor comfort, which falls on the 20th of July at 17:00.

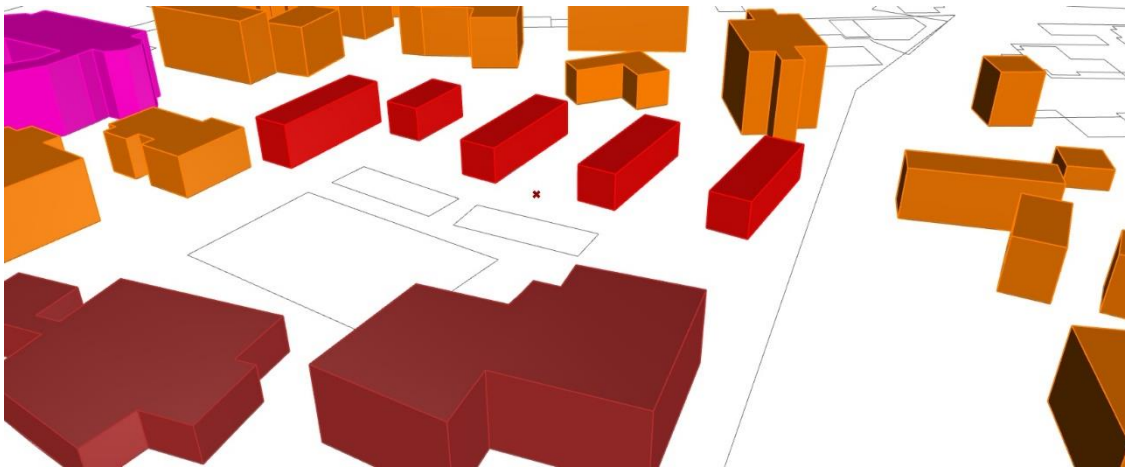

Figure 35 Point studied for calculation of hottest hour of the year

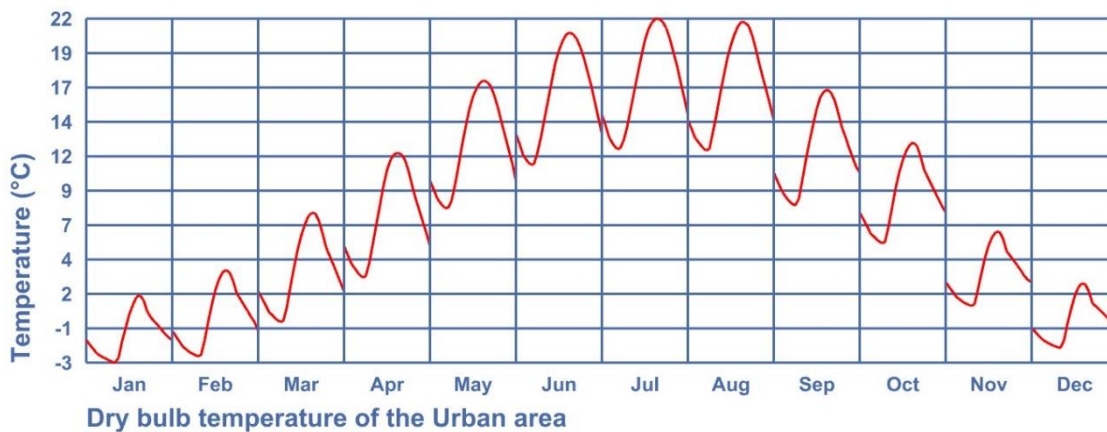

Figure 36 Averaged dry bulb temperature for the urban area on "Today's Scenario"

5.2. The air temperature difference between the weather station and today's scenario

The first step to understanding how the weather station and the urban area differ in temperatures is by calculating the dry bulb temperature for both cases; however, this does not explain the outdoor comfort of the citizens. In order to consider outdoor comfort, the following chapters will show the difference in UTCI values. The following pictures show the hourly plot of dry bulb temperature for the weather station and the urban area in the current status quo (scenario 1).

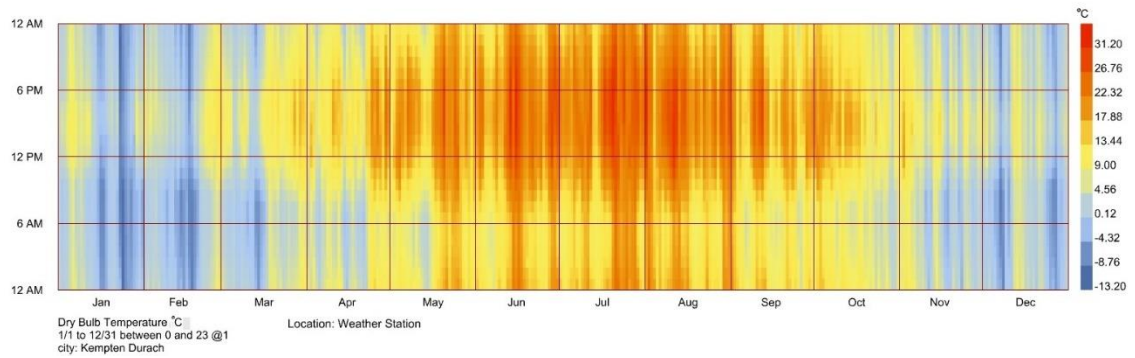

Figure 37 Hourly representation of the dry bulb temperature for the whole year for the weather station

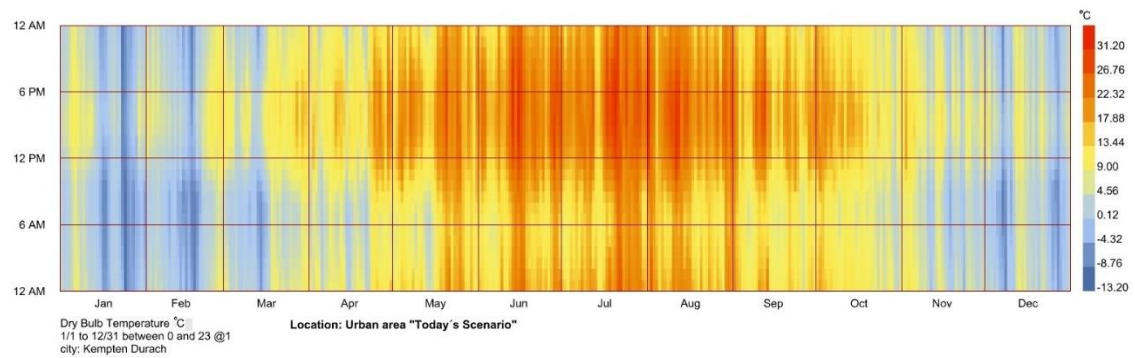

Figure 38 Hourly representation of the dry bulb temperature for Today's scenario

In order to understand the difference between these two different study areas, we created a graph of the difference, which can be seen in the figure below:

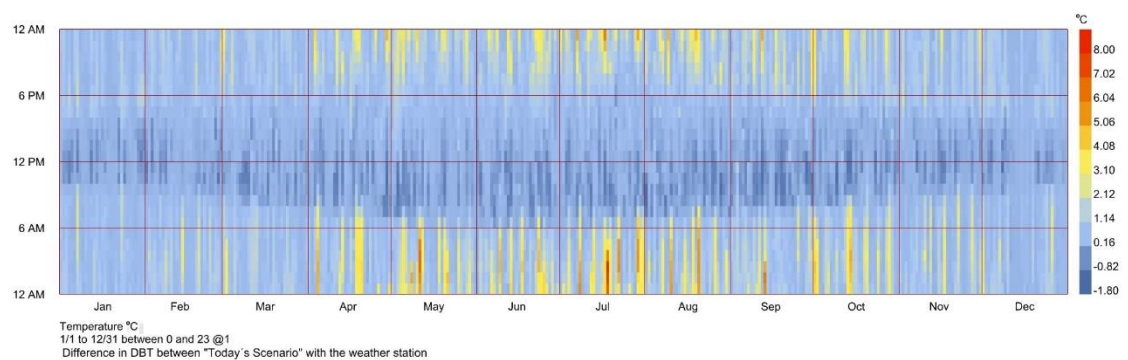

Figure 39 Hourly dry bulb temperature difference between "Today's scenario" and weather station

We can see that the increase in temperature in the urban area is highest during the night hours, from 6 PM to 12 AM and from 12 AM to 6 AM. Meanwhile, during the day, they are hours when it gets cooler inside the city but on a lower scale compared to the temperature increase at night. The highest increase in nighttime temperatures (see figure nr.39) happens in the hotter months (April to August). We are primarily interested in hot

weather conditions, which is why we deepen our search into July (see figure nr.40), where our hottest UTCI hour falls, and further into the hottest day, the 20th of July. For these two specific cases, we show in the following figures the difference in dry bulb temperature between the weather station and the urban area for scenario 1.

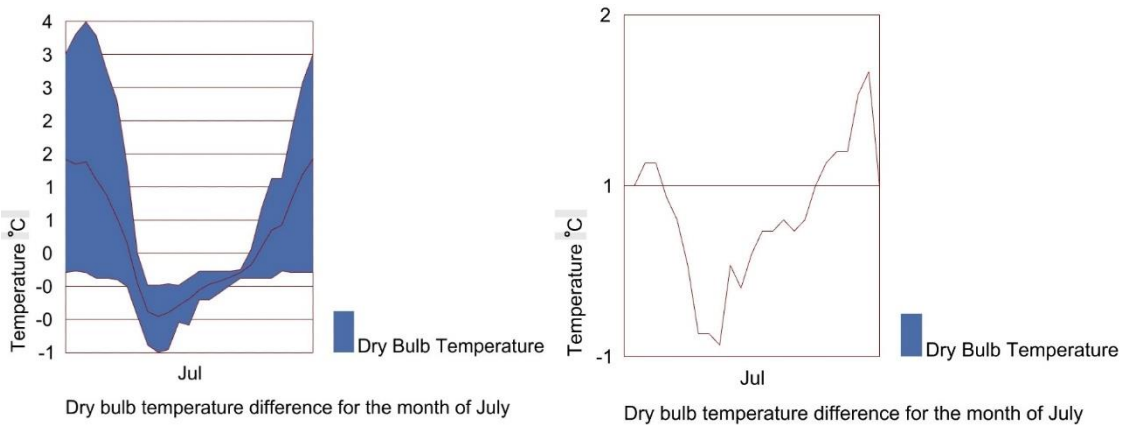

Figure 40 (a) Dry bulb temperature difference for each day in July between Today's scenario and the weather station (b) difference averaged over July

The values for the graphs are taken by the difference from the urban area for scenario 1 to the weather station. For the hottest day (20.07), we notice here the UHI effect, where we see that during the night hours, we receive higher temperature values for the urban area. We reach a daily average UHI intensity of 0.23°C, an average increase during the night of 0.7°C, and a maximum increase of 1.5°C at 23:00 (see figure nr.41).

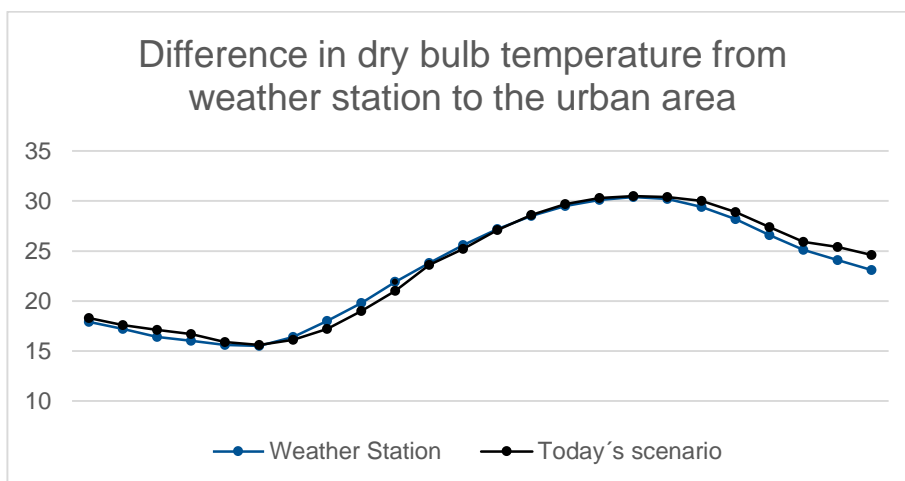

Figure 41 Difference in DBT between the weather station and urban area for the hottest day (20.07)

5.3. Change of air temperature from today's scenario to the different densification and vegetation scenarios

This chapter will show the results of the difference in dry bulb temperature between the different densification and vegetation scenarios. All the densification scenarios will be compared to scenario 1 to calculate how different densification techniques affect the air temperature. However, the vegetation scenario 5B will be compared to both scenario 1 and scenario 4 in order to understand the effect of adding trees. These differences will be shown on the hottest day of the year (here 20.07).

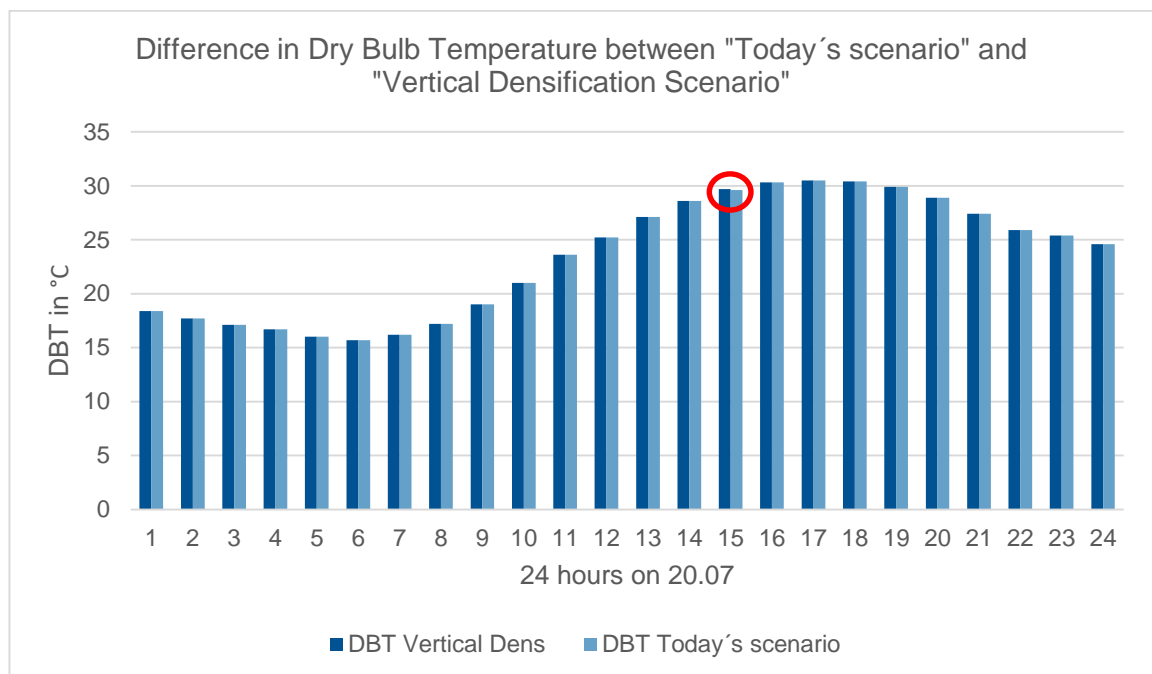

Figure 42 Difference in DBT between the "Vertical Densification Scenario" and "Today's scenario"

Figure nr. 42, gives the graph of the difference in-between scenario 1 and scenario 2. Here we show only this difference because, for the other densification scenarios (3&4), this graph looks the same for this date. We note here that we receive an increase at only one hour of the day(14:00) of 0.1 °C. However, this increase in temperature happens only for a couple of hours during July. On the contrary, in July, we get mainly hours with a decrease in air temperature, which reaches the maximum of -0.3°C.

Furthermore, when it comes to Scenario 5A and its comparison to scenario 1, we get a difference only in one hour of the day, but, in this case, we have a decrease of -0.1°C

at 15:00 which means the temperatures are lower in the case with vegetation. For scenario 5B, we see the highest effect on the dry bulb temperature compared to the case without vegetation since the % of vegetation added here is significantly higher. In this case, because of the added vegetation, we see that in 6 hours of the day, we get a decrease of the dry bulb temperature by 0.1 °C (see figure nr.43). For July, the maximum decrease in the temperature reached by adding trees is 0.3°C.

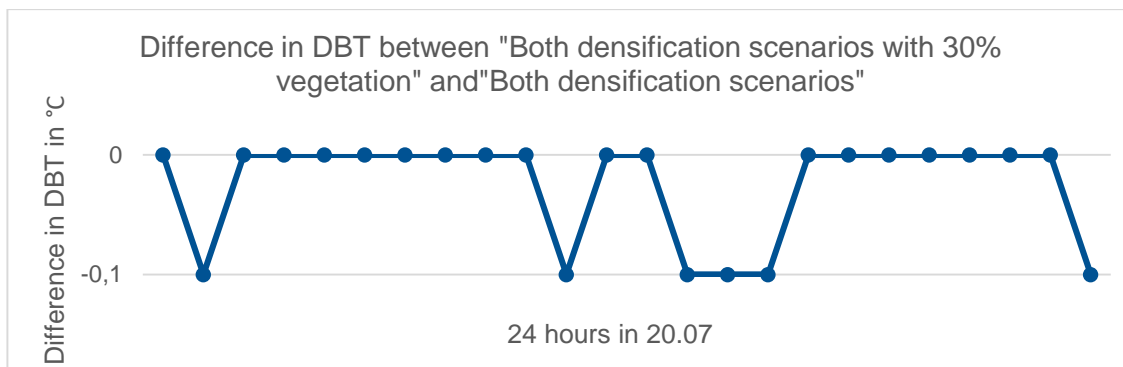

Figure 43 Difference in dry bulb temperature between "Both densification scenarios with vegetation" and "Both densifications scenario"

In order to understand how much densification affects the air temperature reduction that vegetation brings, we also compare scenario 5B to scenario 1, which means here, both densification and vegetation addition happen. This brings only one hour of difference at 14:00, where due to densification, we do not get the decrease of temperature of -0.1°C (figure nr.44) as shown in the previous figure. Therefore, we note that vegetation helps decrease the negative impact that densification brings on air temperature.

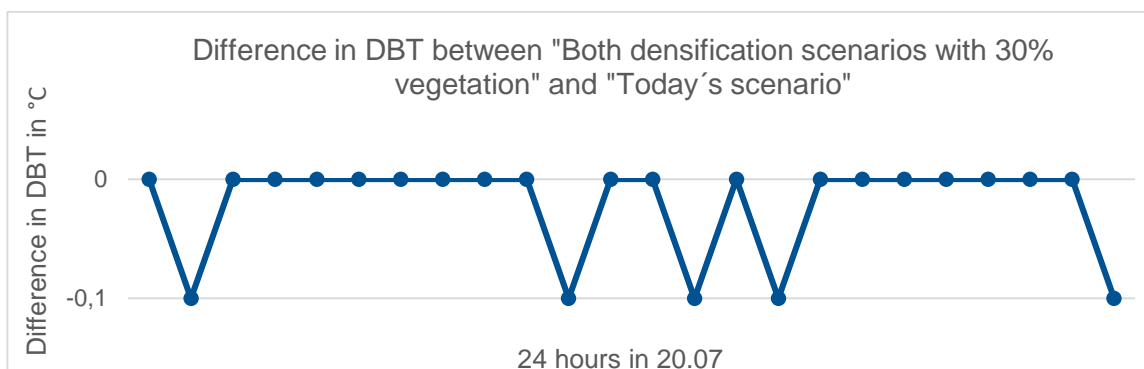

Figure 44 Difference in DBT between "Both densification scenarios with 30% vegetation" and "Today's scenario"

5.4. The difference in MRT between scenarios

The mean radiant temperature, which is one of the most important parameters for the calculation of thermal indexes [101, p. 282], is the second step of our microclimate analysis. To calculate the difference in Mean Radiant temperature between scenarios, the heat maps of different scenarios averaged over 24 hours will be shown. In the next step, the difference between daytime and nighttime for two extreme scenarios will be displayed (Scenario 1, Scenario 4).

5.4.1. Heat maps of MRT for different scenarios

Within this subchapter, we have visualized the heat map of scenarios 1, 4, and 5B of the study area, averaging over 24 hours for 20.07. These specific scenarios were chosen to show the difference between the status quo of the urban area (scenario 1) compared to the maximum densification scenario (scenario 4) and vegetation (scenario 5B). In the maps (figure nr. 45), we can see the effect the addition of buildings brings in the shading of the area, which leads to an average cooling. This decrease in MRT can especially be noticed in the areas very close to where densification happens (in figure nr.46 left). The chosen study points (see figure nr.46 left) show that the decrease in daily average MRT values ranges between 1.96°C for point 1 to 6.02 °C for point 2. In specific hours this decrease can reach up to 24.56°C for point 2 at 16:00 as the horizontal densification causes a change from a sunlit to a shaded place. We choose to represent here only two points, as a more profound calculation will be held for the values of UTCI. When comparing the difference between scenarios 4 and 5B, which considers the addition of trees, it is noticed that in the areas where we have the addition of trees, there is a significant decrease in MRT since we have an increased amount of shade (see figure nr. 46 right). For a point below an added tree, we get an average daily reduction of around 12.6 °C, while during the day, it also reaches a reduction of 29.74 °C.

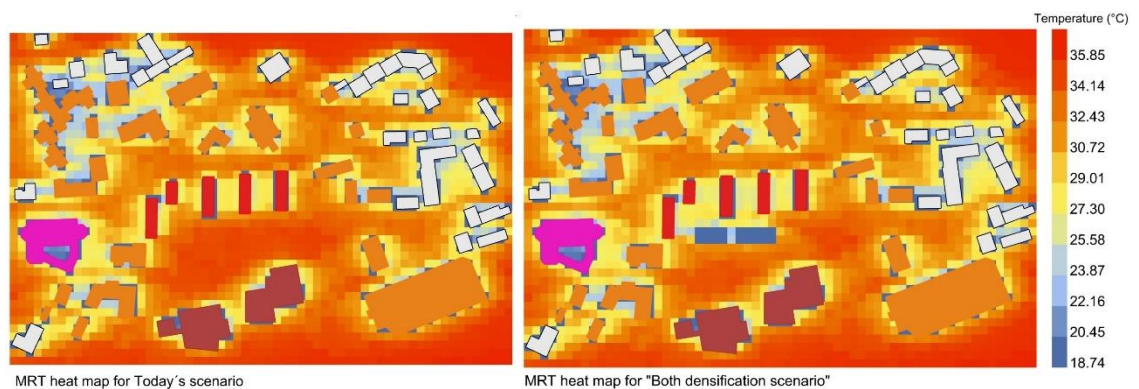

Figure 45 MRT heat maps for scenario 1 (left) and scenario 4 (right)

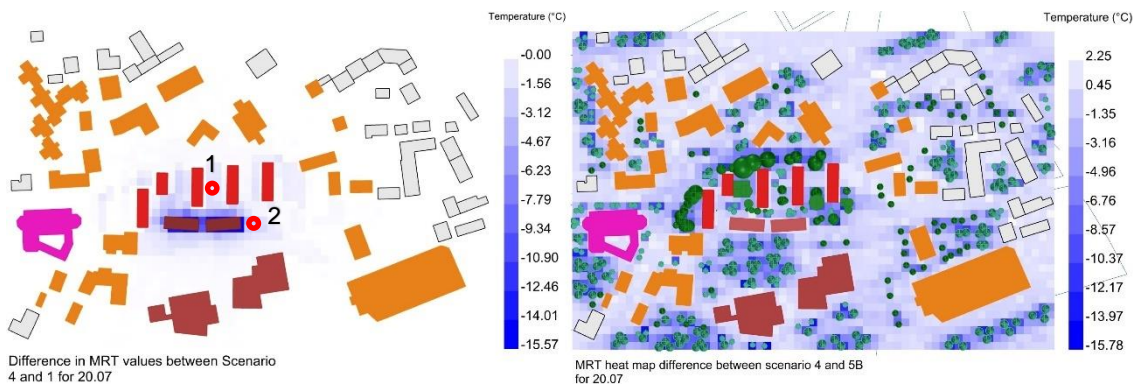

Figure 46 MRT heat map difference between scenarios 4 and 1 (left) and between scenarios 5B and 4 (right)

However, to further understand the effect of densification in the MRT values, we create the difference in heat maps between the two scenarios and divide day and night to see this effect in different time frames. In order to divide the hours between daytime and nighttime, we have checked the typical hours of sun in Germany for July through different years [102]. The average hours of sun in July, which is also the month we are studying, is 16 hours, with a sunset at around 05:00 and sunset around 21:00 [102]. Therefore, for our calculation, we will consider daytime between 05:00 to 21:00 and nighttime between 21:00 to 05:00.

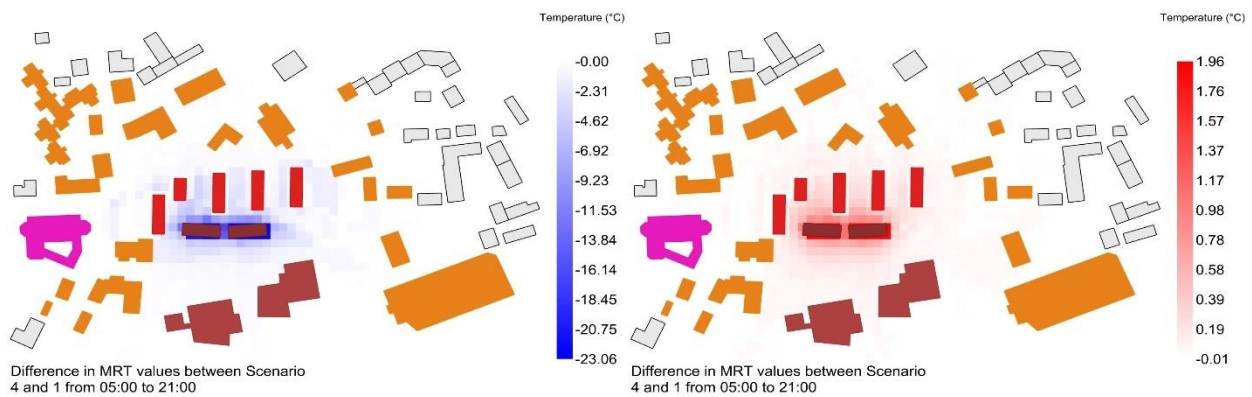

Figure 47 Difference between scenarios 4 and 1 during daytime (left) and during nighttime (right)

Due to densification, we have a clear reduction in temperatures during the daytime due to more shading in the areas next to the newly added buildings. While during night time we get a slight increase in temperatures where densification happens, an average of 0.70°C (point 2) and 0.43 °C (point 1) because the SVF is decreased and the heat gets trapped inside the urban canyon. This slight increase during the night hours compared to the drop in temperature during the day also explains that for the 24 hours heat map, we have an overall reduction of the MRT in the urban area.

5.5. The difference in UTCI between scenarios (heat maps)

This thesis's primary results are based on the Universal Thermal Climate Index calculation. The first step for the calculation of UTCI is the creation of heat maps for each scenario for the complete urban area and the understanding of the effect each of them has on the outdoor comfort of citizens. With the heat maps, we will only represent the effect of densification on the hottest hour of the hottest day, which has been determined in the previous chapters. Therefore, all the results shown here will be for the 20.07 at 17:00. The difference at night or during the day will be shown in the next chapter, where four representative points will be discussed.

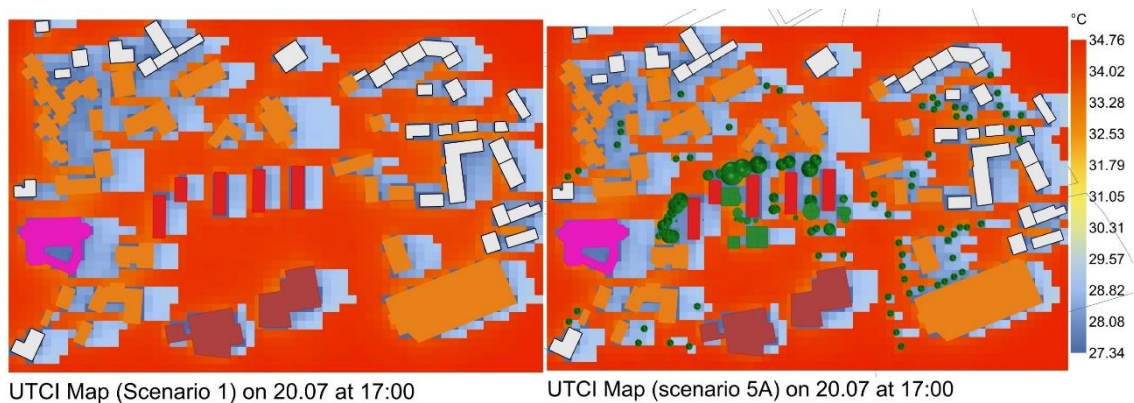

Figure 48 UTCI maps Today's scenario (left) and Today's scenario with vegetation (right) on 20.07 at 17:00

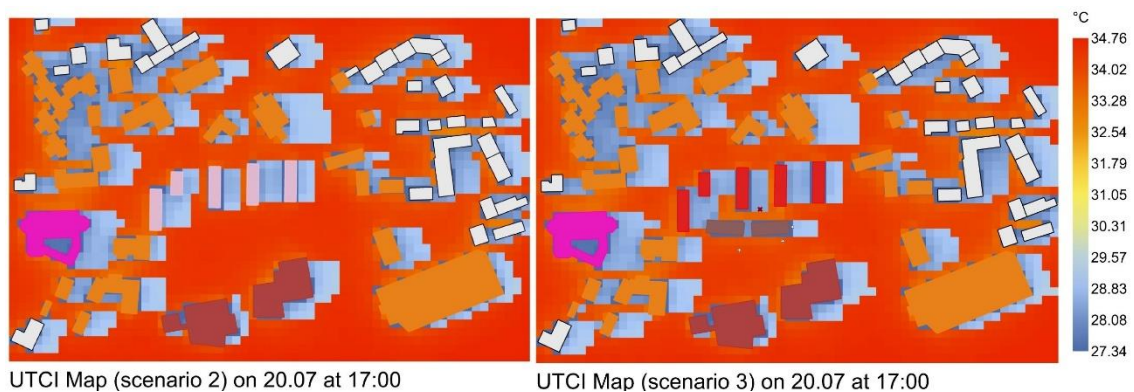

Figure 49 UTCI maps Vertical densification scenario (left) and Horizontal densification scenario (right) on 20.07 at 17:00

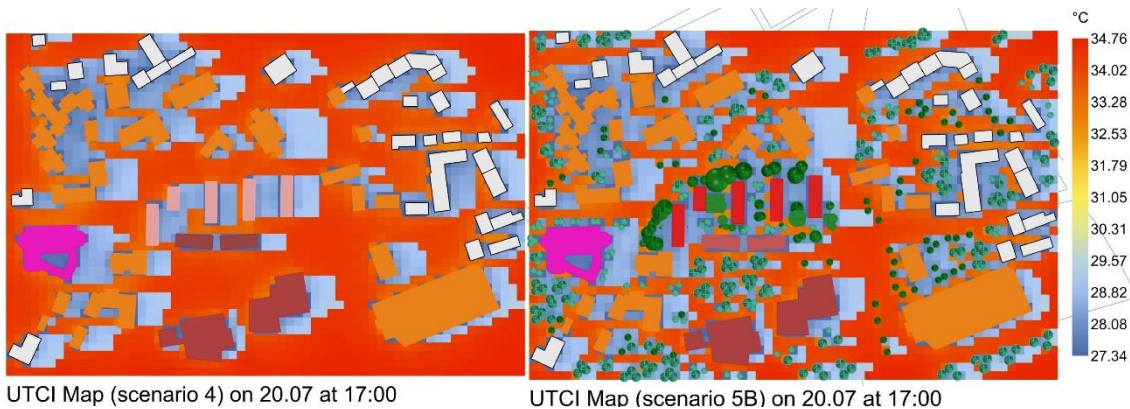

Figure 50 Both densification scenario (left) and Both densification with vegetation scenario (right) on 20.07 at 17:00

In the heat maps, we can see the effect of the additional buildings or floors in the shading pattern of the urban area. Close to the newly added buildings, we can see a clear drop in temperature compared to the sunlit cases. Apart from the buildings, in the vegetation scenarios, we can see the shading effect of the trees during the day.

5.6. Calculation of the scenario with the highest impact on outdoor comfort

The aim is to initially define the densification scenario with the highest impact on UTCI in the urban area. A comparison between 3 different points in the urban area for different scenarios is conducted to understand which densification scenario brings the highest temperature change compared to the status quo. Therefore, in order to assess more detailed information, study points are extracted as depicted in figure nr.51; each study point represents a different phenomenon:

- Shaded before and after densification
- Not shaded before but shaded after the addition of two new buildings
- Not shaded before and not shaded after
- Point below a tree (only for comparison of the vegetation scenarios)

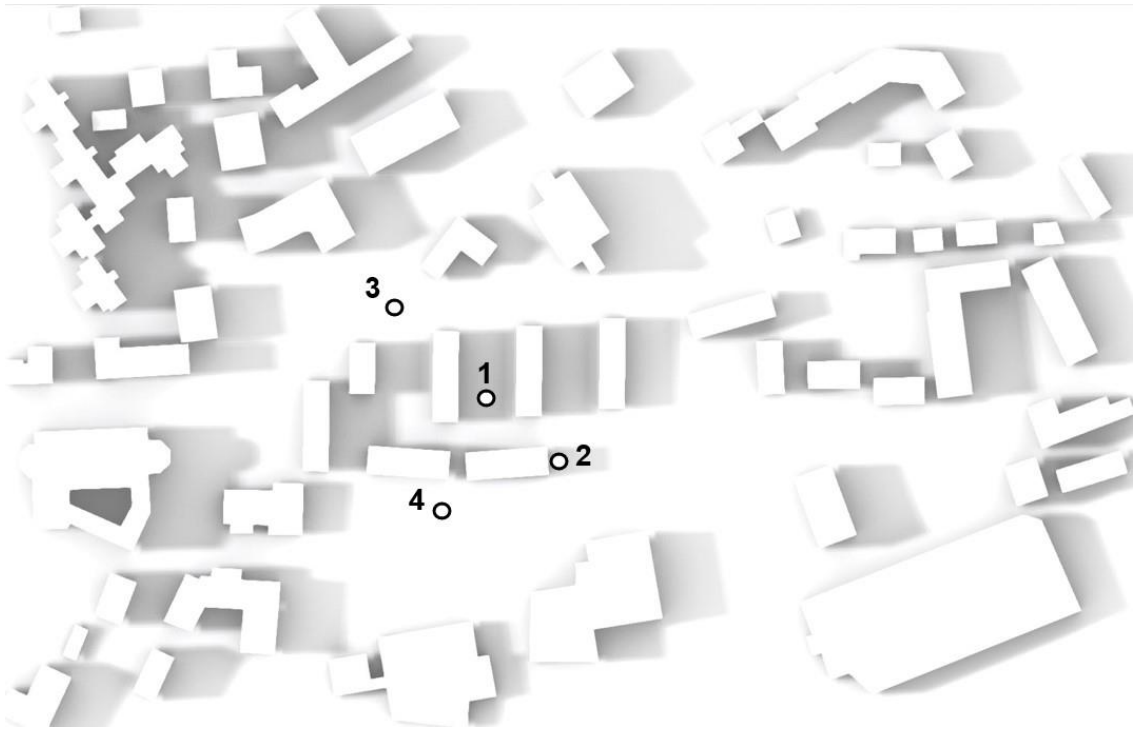

Figure 51 Chosen points of study due to shading conditions at 17:00 (points 1 to 3) and point below a tree (point 4)

The positions are located at: Point 1 (10,10,0); Point 2 (38, -15,0); Point 3 (-25,45,0); Point 4 (-7, -35, 0). The UTCI in the LB tools considers a walking person; therefore, the calculation of the UTCI is made at 1.5 m, so the center of gravity of the person [57] and not the ground of the urban area.

5.6.1. Results of UTCI for point 1

The first point is in the shade before and after densification happens. For this point, the table below shows the values for each scenario and their comparison to the current building conditions. Overall, the vertical densification scenario shows the highest effect in temperature drop, especially at 11 o'clock, where we experience a drop of 4.65 °C for only vertical densification or 5.3°C in the case of both densifications. The horizontal densification scenario, in this case, does not cause this extreme drop in temperatures at any hour of the day (see figure nr.52), but we only see slight temperature changes. However, the trend of temperature remains the same in all scenarios. Overall, during night hours, there is an increase in temperatures, while during the day a decrease. The nighttime effect is the highest in scenario 4, with an average increase of temperatures around 0.14°C. This effect for scenario 3 is, on average, 0.1°C, while for scenario 2, it is 0.05°C. This brings to the understanding that the addition of new buildings is more likely to bring higher nighttime temperatures compared to only the addition of floors; however,

the combination of both brings the highest impact. On the other hand, for this specific point, due to its location, the highest effect because of shading during the day comes from the vertical densification, especially at 09:00. In figure nr.53 is shown that this drop happens because the additional floor keeps the studied point in the shade for one hour longer than in the case without densification. The most significant drop in temperature, comparable to the most considerable increase during the night, happens in the case when both densifications are identified.

Table 13 UTCI values in °C for all scenarios for point 1 and their difference

24 hours on 20.07	Scenario 1	Scenario 2	Scenario 3	Scenario 4	Difference 2-1	Difference 3-1	Difference 4-1
0	16.695	16.748	16.809	16.862	0.0539	0.1143	0.1671
1	16.438	16.506	16.58	16.647	0.0675	0.1423	0.2087
2	16.725	16.799	16.881	16.954	0.0744	0.1563	0.2295
3	16.87	16.945	17.027	17.101	0.075	0.1572	0.2312
4	14.363	14.439	14.522	14.597	0.0759	0.1588	0.2337
5	13.864	13.89	13.921	13.945	0.0258	0.0565	0.0814
6	17.888	17.818	17.747	17.675	-0.071	-0.141	-0.213
7	20.259	20.097	19.93	19.766	-0.162	-0.3286	-0.493
8	21.893	21.661	21.422	21.187	-0.232	-0.4708	-0.706
9	28.355	23.698	27.761	23.057	-4.658	-0.5941	-5.299
10	27.159	26.836	26.503	26.176	-0.322	-0.656	-0.983
11	30.445	30.077	29.695	29.321	-0.368	-0.7505	-1.124
12	30.233	29.862	29.479	29.105	-0.37	-0.7536	-1.128
13	30.617	30.283	29.938	29.602	-0.334	-0.6788	-1.015
14	30.723	30.533	30.228	29.929	-0.19	-0.4952	-0.793
15	32.192	31.96	31.723	31.489	-0.232	-0.4691	-0.703
16	28.535	28.363	28.188	28.014	-0.173	-0.3471	-0.522
17	28.805	28.674	28.542	28.409	-0.131	-0.2626	-0.396
18	27.636	27.56	27.486	27.408	-0.076	-0.1497	-0.227
19	25.906	25.879	25.856	25.828	-0.027	-0.0503	-0.079
20	23.735	23.753	23.777	23.793	0.0178	0.0414	0.058
21	23.255	23.271	23.292	23.306	0.0156	0.0366	0.0509
22	23.862	23.88	23.903	23.92	0.0177	0.0409	0.0573
23	22.842	22.861	22.886	22.904	0.0191	0.0437	0.0615

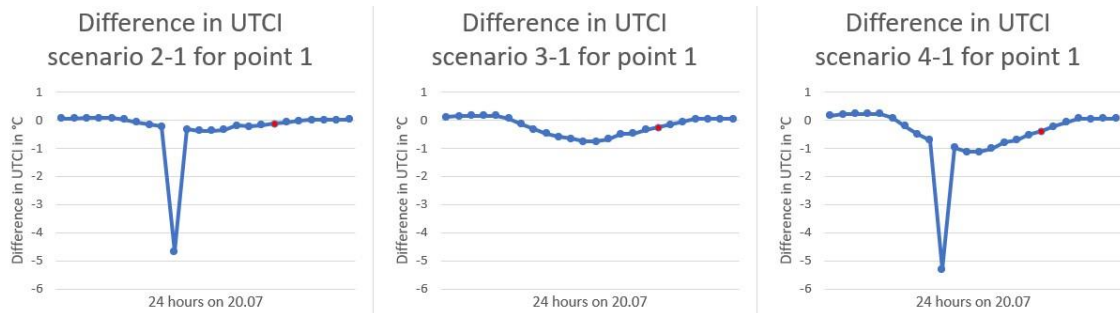

Figure 52 Difference in UTCI of scenarios 2,3,4 to scenario 1 for point 1 over 24 hours on 20.07 (in red is the hour for which the UTCI heat maps are generated)

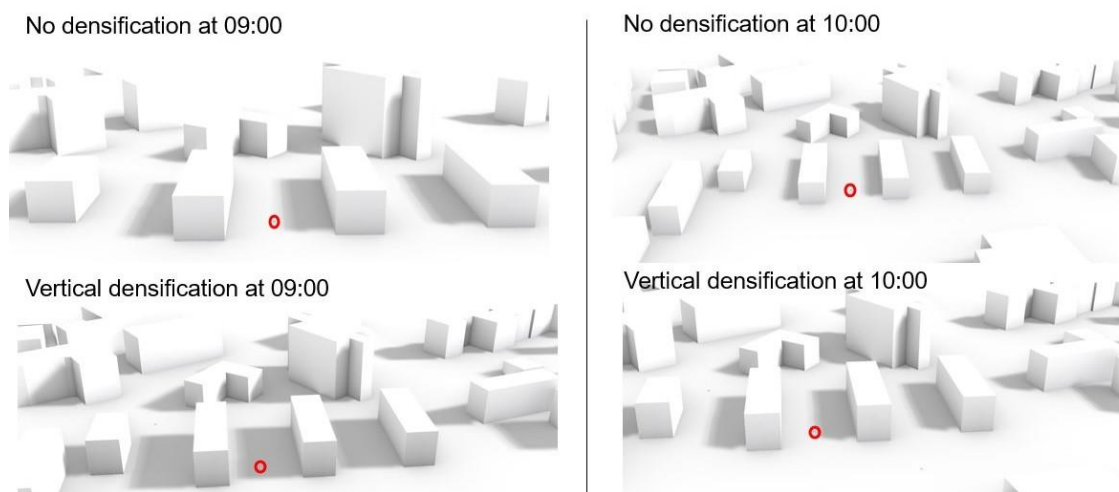

Figure 53 Explanation of the temperature drop at 09:00

5.6.2. Results of UTCI for point 2

The second chosen point is next to the newly added building for horizontal densification. This means, that this point before horizontal densification is sunlit, and after it, it is entirely in the shade. In the results shown in the graphs here, we can notice that the highest effect at this point comes from the horizontal densification scenario. Vertical densification brings very slight changes in the UTCI values. Likewise, we notice an increase in temperatures during the night compared to today's scenario, while during the day, especially for the scenarios with horizontal densification, we have a decrease in temperature. Again, the highest effect in temperatures happens in the scenario where we have the combination of both densifications (see figure nr.54). The average increase of temperatures during the night respectively for scenarios 2,3,4 is 0.015 °C; 0.22 °C; 0.23 °C. The maximum increase in temperature happens at 05:00, about 0.39 °C, and the maximum decrease happens at 16:00 with a value of 5.96°C (these results come from a comparison of scenario 4 with 1). The average temperature decrease during the day is respectively -0.07 °C; -2.6 °C; -2.69°C. As a result, adding the new buildings has the

highest effect on this specific point, especially during the day due to shading. The highest UTCI is reached at 17:00 for scenario 1 with a value of 34.38°C. This value of UTCI means pedestrians experience high heat stress (see table nr.1). This value gets significantly reduced for scenario 3 at 28.64 °C and scenario 4 at 28.58°C. We can conclude that the addition of horizontal densification brings a reduction from high heat stress to moderate heat stress values for this point in the hottest hour.

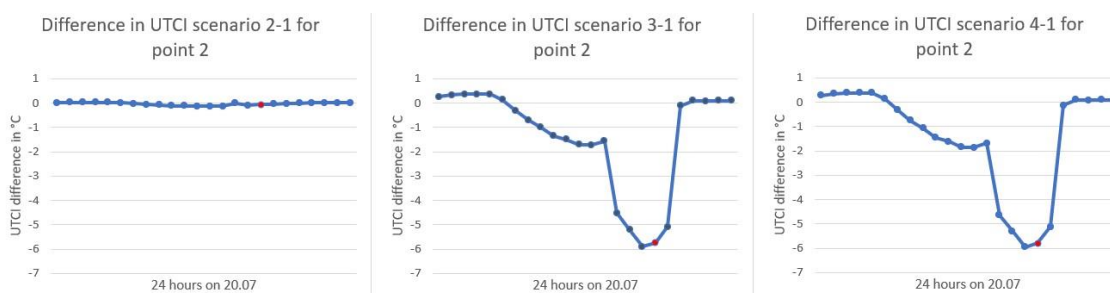

Figure 54 Difference in UTCI of scenarios 2,3,4 to scenario 1 for point 2 over 24 hours on 20.07 (in red, the hour for which the UTCI heat maps are generated remains the same for all following graphs)

5.6.3. Results of UTCI for point 3

The third chosen point remains in the sun also after both densifications are added. Therefore, at this point, we can recognize the effect each densification has in the area and not a direct effect on the specific position. Similar to the two previous points, here we also see both effects: during the night increase in temperatures, during the day reduction. However, because this point is not in the vicinity of the densifications, the effect, in this case, is smaller. We do not notice a big decrease in temperatures (see figure nr.55), which happens due to the fact that no direct shade from the new additions comes to this point. The average night temperature increase, for scenarios 2, 3 and 4 are respectively: 0.01 °C; 0.012 °C; 0.023 °C. The average daily decrease looks as follows: -0.054 °C; -0.045 °C; -0.11 °C. Here, we notice that since the point is closer to the position where the vertical densification happens, the highest temperature reduction during daytime comes from adding the floors in the existing buildings. However, the difference here is in small percentages. During the day, the highest temperature reached at this point is 34.25°C for scenario 1, and this gets reduced with each densification scenario reaching the lowest for scenario 4 by 34.18°C. Therefore, for this point, despite the slight reduction, we remain in the high heat stress area.

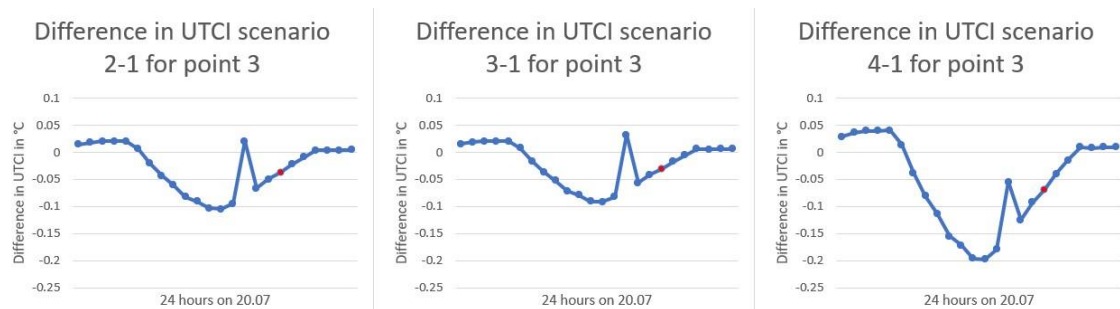

Figure 55 Difference in UTCI of scenarios 2,3,4 to scenario 1 for point 3 over 24 hours on 20.07 (in red is the hour for which the UTCI heat maps are generated)

After comparing the results on the three different points, however, it becomes clear that independent of the position of the point during the night, the temperatures are always higher when horizontal densification happens if only one densification is to happen or even higher when both densifications happen. At the same time, the reduction during the day depends on which densification scenario is closest to the location. Independent of the point chosen, the combination of both scenarios has the highest impact on temperature change in all the studied points. Therefore, for the creation of the vegetation scenario, this specific densification combination was selected.

5.6.4. Results of UTCI for scenarios with vegetation

The vegetation scenarios include two different tree coverage percentages. Vegetation as it is today for the urban area (scenario 5A) and also an increase to 30% of tree coverage for the case when we have both densification scenarios (scenario 5B). The comparison, in this case, will be held on all the above-mentioned points but also on one additional point (point 4) below the tree for the scenario with 30% vegetation. This comparison will be between scenarios 1 and 5A and 4 and 5B to check the influence of adding trees in the urban area. For scenarios 5A and 5B, the location of the points is shown in figure nr.56.



Figure 56 Location of study points in scenario 5A (left) and scenario 5B (right)

Firstly, we compare scenario 1 and scenario 5A. During the daytime, we see a decrease in temperatures for any point chosen. Depending on the location of the point and the number of trees surrounding it, the amount of the decrease changes. From points 1 to 4, the average decrease during the day is respectively: -1.57°C ; -2.29°C ; -4.02°C ; -0.71°C . We see that for point 3, we have the highest decrease in daytime temperature since the point is surrounded by a high number of trees which create shade with a maximum decrease of 6.77°C at 09:00. While for point number 4, which is not in the proximity of any of the trees, we see that this decrease is in a smaller scale reaching a maximum of 1.2°C . However, for the nighttime, the trees show a different effect; they show an increase in the UTCI for the urban area. The average nighttime increase in temperature from point 1 to 4 is as follows: 0.176°C ; 0.179°C ; 0.3°C ; 0.15°C . According to these results, the highest increase in temperature happens at point 3, similarly to the highest decrease. Therefore, the trees are also considered an obstacle for the SVF and do not allow the heat to release into the atmosphere. The graphs of the difference between scenarios 5A and 1 for the different points are shown in figure nr.57.

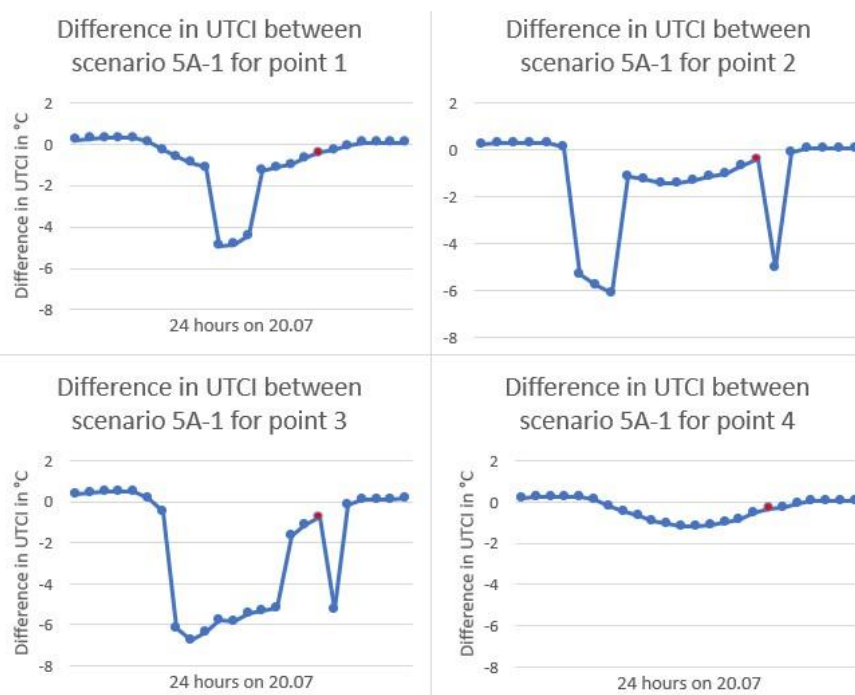

Figure 57 Difference in UTCI between scenarios 5A-1 for different study points

Secondly, we compare scenarios 4 and 5B. We calculate two vegetation scenarios due to the fact that we jump from the vegetation of 10% to 30%, which is a recommended tree coverage percentage in order to combat the adverse effects of densification.

The trend of the temperatures here is similar to the comparison discussed previously. For daytime, we have a decrease in temperatures for each studied point because we have additional shading. The average reduction of daytime temperatures on the 20th of July for points 1 and 2 (respectively -1.46°C; -1.86°C) are lower than for points 3 and 4 (respectively -4.19°C; -5.46°C), which comes due to the higher number of trees added in the proximity of points 3 and 4. Overall, we see in the points in scenario 5B a higher reduction of the temperatures, which comes from the higher tree coverage compared to scenario 5A. For nighttime hours, the trend is again the same; higher temperatures are measured for UTCI. For all the points, we notice a higher increase in average nighttime UTCI than in the previous comparison between scenarios 5A and 1. From points 1 to 4, this increase is 0.136; 0.14; 0.32; 0.42 °C. The highest reduction in UTCI during daytime happens for point nr.4 with a value of 7.42°C. Similarly, the highest increase during the night happens again for point nr. 4 at 04:00 with a value of 0.72 °C. The tree addition makes the values of UTCI go from high heat stress to moderate heat stress in several hours of the day. The results of the differences between scenarios 5B and 4 for the 20.07 can be seen in the following figure.

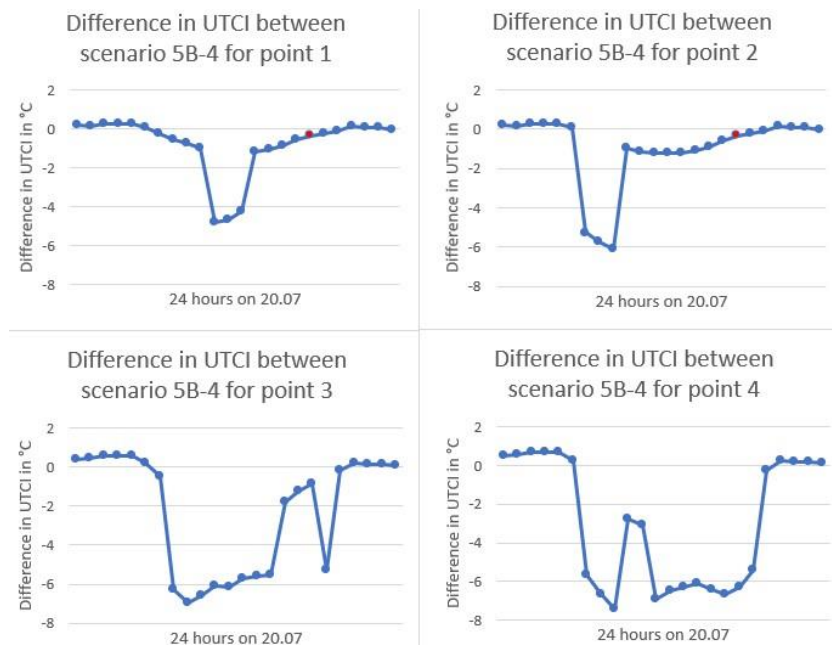

Figure 58 Difference in UTCI between scenarios 5B-4 for different study points

5.7. Discussion of results

In this subchapter, the meaning of the results received from our case study will be compared to previous studies with a similar character. The DBT comparison is shown in two parts: 1. Comparison of the weather station and urban area; 2. Comparison of today's scenario with densification scenarios.

5.7.1. Dry bulb temperature results comparison and discussion

The results of this thesis show that between the weather station and the urban area, we notice the UHI effect. Especially during nighttime, we see an increase in air temperature in the urban area because the heat gets trapped inside the urban canyon. Other studies have had a similar conclusion where urban structures do not allow urban areas to cool in the same way as rural ones because these structures discharge during the night the heat they have absorbed during the day [103, p. 178]. A study held in Würzburg, Germany, where different neighborhoods in the area were considered, showed an increase in temperature in the city center of around 1.3 °C compared to the surrounding areas [104]. However, this study showed that the increase in the temperature depends on the location and the intensity of the built environment. Comparing the city center to different sub-urban sites brought a different increase in nighttime temperature ranging from 0.5 to 1.0 °C. [104] Therefore, we can say that the results of the increase in DBT are site dependent and it varies depending on the density of the built environment. Studies held in Barcelona, which evaluated the accuracy of the results coming from the UWG, showed a 0.6 °C increase for the month of July in the urban area compared to the weather station [37]. Furthermore, the graph resulting from the comparison of the weather station to an urban area (see figure nr.59) shows a similar trend to the one that results for our study area (see figure nr.41) for the hottest day[37]. Another study, held in a medium-density city in Australia, concluded a daily UHI intensity of 0.3 °C on average during summertime [17, p. 2541], comparable to our result of 0.23°C.

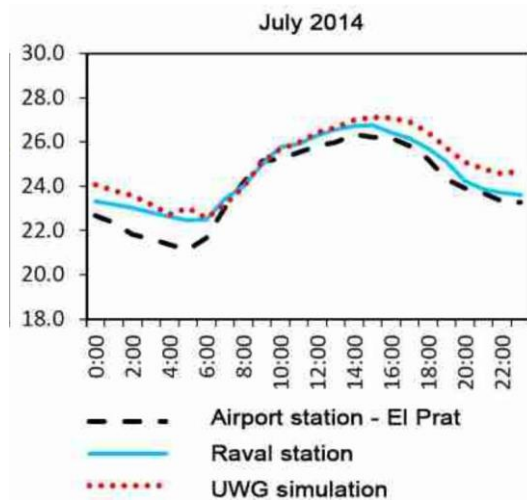

Figure 59: Salvati, Coch Roura et al. 2016 - Urban heat island prediction.jpg [37]

Our densification scenarios bring only a little effect on dry bulb temperature. Overall, a decrease in DBT is noticed for July, reaching a maximum of 0.3°C. A study held in Toronto, Canada, came to the conclusion that the air temperature gets reduced by around 1 °C when additional buildings are added at the locations of parking lots, with a specific remark that this air temperature change is highly dependent on the effect that the buildings cause to the wind speed[19]. However, the spots that receive this decrease in temperature are located close to the additional buildings and are also combined with spots where the wind speed gets increased[19]. Our results also show an average reduction of the DBT but on a smaller scale, which could be assigned to the fact that we do not calculate it in specific points (so close to the addition of densification), and we do not take into consideration what the new buildings cause to wind speed.

Regardless of the amount of vegetation, the maximum temperature decrease achieved for our study case for 20.07 was 0.1°C. With the increase in tree coverage, this decrease happened in more hours of the day. This reduction reached a maximum of 0.3°C in July. A case study held in Southwest Germany, where the influence of trees and grassland on the study area previously only with asphalt with the use of Envi-met was discussed, concluded that trees bring a mean reduction of 0.6K during the day and 0.3K during the night for a selected day in August [105, p. 46]. The values compared to this study differ, but also in our case, the reduction of air temperature from tree addition is higher during the day than during nighttime. This difference in results comes due to the use of different softwares for the calculation of outdoor comfort in both cases. Furthermore, compared to a study that also uses the UWG, the same decrease of 0.1K when changing a parking

lot from concrete to an area with vegetation is reached [35]. Concerning the maximum decrease of 0.3 °C achieved by adding trees in our thesis, the same result was achieved by a previous study where the accuracy of the UWG model was inspected [36, p. 12]. Previous studies have, however, pointed out the poor consideration of evapotranspiration of trees in the Ladybug tools; therefore, this should be considered in the results achieved in this study [106].

5.7.2. MRT results comparison and discussion

While comparing different densification and vegetation scenarios with the current status of the study area, we can see in the heat maps conducted in the previous chapters of this study, that the main effect on MRT is noticed in the areas close to where densification/vegetation happens. This can also be seen when dividing between day and night time where we notice that the additional cooling because of shading (day) or heat trap (night) happens in the areas close to the addition of buildings/floors (see figure nr. 47). A similar result is concluded in this study, with the explanation behind it attributed to the fact that higher shade rates and narrower areas for heat dissipation arise due to the addition of buildings. [107]

Our case study showed a significant decrease in the MRT values. For a chosen study point, we see a daily average reduced MRT of around 6.02°C, which is similar to the result in this study held in Austrian cities, where the overall MRT is reduced by around 7°C [15]. A similar range of MRT reduction to our values of 1.96 to 6.02°C depending on the location was concluded from a study in Linz and Vienna, Austria, where the MRT change appeared to be between 1 and 7°C [107]. Our case study concluded that the most significant change in MRT was noticed during the daytime, while during nighttime, the average MRT increase reaches about 0.7°C. Similar results were concluded by a study in the city of Vienna, where nighttime MRT changed by about 0.5K [16, p. 12] or in another study, a result of 0.4°C, which in any case remains on a smaller scale [15].

The potential of trees for reduction of temperatures of around 12°C, in our study area, shows similar results to previous studies, which show a reduction of more than 11°C in a study in Austria [15] or 10 °C in a study held in Helsingborg [20]. A study in Linz, Austria, concluded that temperatures below trees could be reduced up to 30 °C [15], which would be similar to the reduction of 29 °C we get for a point below a tree in the sun peak hours.

5.7.3. UTCI results comparison and discussion

The UTCI heat maps presented previously show an apparent reduction of the UTCI values in the urban area for the hottest hour of the day, especially close to where densification or addition of trees occurs. Depending on the chosen point, the effect in UTCI varies. In general, for all study points, we notice an increase in temperatures at night and a decrease during the day. For the specific points chosen in this thesis, we reach a maximum decrease of 5.96 °C(daytime) and a maximum increase of 0.39 °C(nighttime).

During the day, the reduction in temperature is more position-dependent; when the point is in the vicinity of the location where a specific type of densification occurs, that densification type has the highest impact due to the shading effect. On the contrary, during the night, scenarios that include horizontal densification bring the highest impact independent of the location of the points due to the higher building mass added, which releases the heat trapped during the day at night. To answer our first research question, we conclude that if only one densification scenario has to be considered, then horizontal densification brings the highest impact in the increase of nighttime temperature, but this differs for reduction of temperatures during the day, which is more location dependent. However, the highest impact, whether in the increase or decrease of temperatures, comes from the combination of both densifications. In specific points close to the addition of densification, an improvement in daytime UTCI from high heat stress to moderate heat stress was noticed.

A study held in Vienna, where the same simulation tools were used, brought a similar conclusion to our study case, where an increased shading was noticed during the day and, therefore, lower temperatures, but during night times, higher temperatures [16, p. 19]. Although the results are shown for MRT, the difference between the nighttime to daytime temperatures is comparable to our results, with a very slight increase in temperatures during the night (0.5K) but a significant decrease during the day (up to 10K) [16, p. 19]. Similarly, a study held in Munich, Germany, came to the conclusion that the increased shade from buildings during the day brought better comfort conditions for citizens [108, p. 11]. A study held in Canada studied the effect of densification in different locations concluding with different amounts of PET reductions depending on the relationship to densification[19]. This was further confirmed from a study held in Egypt, where different points were studied, showing an inconsistency in PET reduction values depending on the impact densification brings to each specific point which during the day shows the effect of shade in the area [109, p. 34].

The tree addition in the urban area shows a trend of reduced UTCI values during daytime and an increase during nighttime. The reduction in temperature is higher whenever the overall tree coverage is higher; this can also be seen at points where the number of trees surrounding it is high. The maximum cooling effect for our case study is around 7.4°C during the day due to the increased shade and also evapotranspiration process [110, p. 4], bringing in several hours of human comfort to be in a moderate stress state, while the maximum increase is 0.7°C due to the blocking of SVF.

A similar result is noticed in this study, where adding trees reduces the area where longwave radiation can dissipate towards the sky and brings a slight increase in nighttime PET temperatures of around 0.9 °C [108, p. 12]. On the other hand, tree canopies during the daytime reduce the amount of shortwave radiation that reaches the pedestrian level and bring more shade, creating cooler spaces in the pedestrian level (around 4°C reductions in PET) [108, p. 11]. Furthermore, a study held in Zürich where a similar effect during the night was noticed pointed out the importance of the change in wind speed addition of trees can cause reducing the amount of heat able to dissipate, and on the other hand, evapotranspiration of trees during the night is negligible due to the lack of solar radiation. [111, p. 6] A study that used the Ladybug tools for calculation of the effect tree addition has on UTCI concluded that a maximum of 3.9 °C reductions could be achieved [112, p. 119]. However, in this study, trees were not considered in groups, and the body locations were not directly below the trees [112, p. 118], which explains the difference in values to our study case. Nevertheless, it must be kept into consideration that Ladybug tools do not consider the shade of trees as a configuration of different leaves but considers the canopy as one solid [112, p. 120].

6. Conclusions

This study investigated urban densification as one of the solutions to combat the further sprawl of cities due to the continuous demand for housing in urban areas and its influence on the comfort of citizens. The thesis was developed to contribute to the local/neighborhood scale microclimate effect of densification strategies and tree coverage impact. Although there are many studies calculating the influence of densification, few of them compare the effect different densification types have on outdoor comfort in specific study points. Furthermore, the addition of trees and their impact on outdoor comfort is excessively studied during the daytime, but the impact of trees in nighttime temperatures is lacking. By use of the UWG model, the impact of urban morphology on air temperature was calculated both for the current building state as well as the addition of densification and greenery. The Ladybug tools were then used for the generation of UTCI heat maps of the chosen study area and for calculating outdoor comfort at different points of the area.

This study compared six different scenarios, including different densification techniques and tree coverage percentages in the area of Kempten, Germany, which shows temperate climate conditions. The results taken in this study were focused on 4 study points, each representing a different phenomenon and a different location. Our results show that, generally, densification brings a significant decrease in UTCI values during daytime due to the increased shade in the urban area. Meanwhile, a slight increase in UTCI during nighttime is noticed due to a lower value of SVF where heat can dissipate and increased building mass which means increased thermal mass. The densification with the highest impact changes with changing the position of the point studied during daytime. We note that during the day, depending on which densification type the point is closest to, this type of densification brings the highest decrease in temperature due to the shade it creates. However, during the night, this phenomenon changes. Independent on the point chosen to study, the highest increase in nighttime UTCI values comes from horizontal densification. This occurs because the increase in the number of buildings implies that due to more thermal mass, more heat may be trapped throughout the day inside the urban areas than if only one story is added to each existing structure. In general, the scenario which includes both densification scenarios brings the highest impact, whether during the day or nighttime, independent of the location studied. The tree addition brings a significant decrease in daytime UTCI. During several hours of the day and

in different locations, trees help improve outdoor comfort from high heat stress to moderate heat stress for citizens. However, a negative impact on outdoor comfort during the night due to adding trees is concluded. The nighttime UTCI experiences a slight increase due to the additional blocking of the sky and also due to the fact that the positioning of the trees can reduce wind speed in the urban area. However, wind calculation and the effect of added densification or trees on wind direction and wind speed were neglected in this study. To conclude, both addition of densification and trees brings a slight increase in nighttime temperatures.

This study was limited to an extreme summer day in order to consider climate change since elevated temperatures are expected in the following years. The results from this study are site dependent. However, when urban comfort throughout the year, in a different location, or a different climate has to be calculated, the developed parametric flow can be applied. For the purpose of this study, simplifications were made in the positioning of the trees for future vegetation scenarios.

This thesis gives an insight to urban planners and stakeholders during the initial design phase of the effect that densification brings in the outdoor comfort of the citizens as well as the impact of trees. Future work should include wind simulation to understand the effect of the planned buildings and trees on wind speed and propose a smart positioning of them to reduce the negative impacts. Driven by the increase in nighttime temperatures coming from both addition of densification and trees, future studies should calculate to what extent this slight increase could be accepted by city planners in order to create comfortable environments for citizens. Considering the results differ spatially, seasonally, and depending on the urban morphology, the parametric flow should be implemented in more study areas and in other seasons to create guidelines for the impact of densification and vegetation throughout the whole year. Furthermore, studies calculating the effect of densification on the indoor comfort analysis should be implemented.

Key Messages:

- The addition of trees has a significant impact on improving the daytime temperature at the pedestrian level in extremely hot conditions. However, greater attention should be drawn to the slight increase in UTCI values they can cause during nighttime.

- The addition of buildings brings higher negative impacts in nighttime temperatures compared to additional floors in existing structures independent of the study point in the urban area. Therefore, the use of vertical densification causes a more negligible negative impact on the comfort of citizens.
- The use of UWG can help planners predict temperatures in specific study sites where densification or addition of trees is discussed, compared to values of a weather station with a specific climate or the site in the current conditions.

7. List of Figures

Figure 1: Erlström 2020 - Urban heat island effect [20]	12
Figure 2: How does human comfort get affected by the environment [32]	17
Figure 3 Thesis methodology diagram	22
Figure 4 The connection between the different Ladybug tools and their different specializations [51].....	25
Figure 5 Connection of the tools used in the parametric workflow of this thesis [51] [53] [54]	25
Figure 6 Parametric flow for the creation of buildings for the Dragonfly model	27
Figure 7 Component connection for the run of the UWG model	29
Figure 8 Parametric flow for the run of the OSM	31
Figure 9 Preparation of an hourly data collection for outdoor surface temperature.....	32
Figure 10 The use of Pando for the addition of trees for the UWG model in the simplified study area (lower left corner)	33
Figure 11 Parametric workflow for calculation of MRT and UTCI	35
Figure 12 Heat map visualization parametric flow	35
Figure 13 Difference between heat maps for two different scenarios	36
Figure 14 Location of the study area in Kempten, Germany [62].....	37
Figure 15 Area chosen for building typology check [64]	
Figure 16 Percentage of building typology	38
Figure 17 Rendered view of the hypothetical densification scenarios.....	38
Figure 18 Sunpath for the weather station in Kempten	
Figure 19 Wind rose for the weather station in Kempten	39
Figure 20 Psychrometric chart for the weather station	40
Figure 21 Today´s scenario of the area (current building conditions without vegetation) (scenario 1).....	41
Figure 22 Vertical densification scenario (addition of one floor in 5 buildings) (scenario 2)	41
Figure 23 Horizontal densification scenario (addition of two new buildings) (scenario 3)	41
Figure 24 Both densifications scenario (combination of the vertical and horizontal) (scenario 4).....	42
Figure 25 Today´s scenario with the addition of trees in the current status quo (scenario 5A)	42
Figure 26 Both densification with addition of 30% tree coverage scenario (scenario 5B)	42
Figure 27 Church of St. Anton, Kempten, Germany [76]	46
Figure 28: Asphalt construction model [81, p. 172].....	49
Figure 29 View to demonstrate the roof color of the buildings in the study area [72] ..	50
Figure 30 The location of the weather station (blue dot) compared to the study area (rectangle) [58].....	52
Figure 31 Input of geometries for buildings and vegetation in Rhinoceros.....	53
Figure 32 Calculation of vegetation coverage in the weather station area.....	54
Figure 33 The captured picture to calculate the grass coverage in the urban area (based on Google Earth [72])	56
Figure 34 Position of the two trees which interfere with the two planned buildings.....	57
Figure 35 Point studied for calculation of hottest hour of the year	60
Figure 36 Averaged dry bulb temperature for the urban area on "Today´s Scenario".	60

Figure 37 Hourly representation of the dry bulb temperature for the whole year for the weather station	61
Figure 38 Hourly representation of the dry bulb temperature for Today's scenario	61
Figure 39 Hourly dry bulb temperature difference between "Today's scenario" and weather station	61
Figure 40 (a) Dry bulb temperature difference for each day in July between Today's scenario and the weather station (b) difference averaged over July.....	62
Figure 41 Difference in DBT between the weather station and urban area for the hottest day (20.07).....	62
Figure 42 Difference in DBT between the "Vertical Densification Scenario" and "Today's scenario".....	63
Figure 43 Difference in dry bulb temperature between "Both densification scenarios with vegetation" and "Both densifications scenario"	64
Figure 44 Difference in DBT between "Both densification scenarios with 30% vegetation" and "Today's scenario"	64
Figure 45 MRT heat maps for scenario 1 (left) and scenario 4 (right)	65
Figure 46 MRT heat map difference between scenarios 4 and 1 (left) and between scenarios 5B and 4 (right).....	66
Figure 47 Difference between scenarios 4 and 1 during daytime (left) and during nighttime (right).....	66
Figure 48 UTCI maps Today's scenario (left) and Today's scenario with vegetation (right) on 20.07 at 17:00	67
Figure 49 UTCI maps Vertical densification scenario (left) and Horizontal densification scenario (right) on 20.07 at 17:00	67
Figure 50 Both densification scenario (left) and Both densification with vegetation scenario (right) on 20.07 at 17:00	68
Figure 51 Chosen points of study due to shading conditions at 17:00 (points 1 to 3) and point below a tree (point 4)	69
Figure 52 Difference in UTCI of scenarios 2,3,4 to scenario 1 for point 1 over 24 hours on 20.07 (in red is the hour for which the UTCI heat maps are generated)	71
Figure 53 Explanation of the temperature drop at 09:00	71
Figure 54 Difference in UTCI of scenarios 2,3,4 to scenario 1 for point 2 over 24 hours on 20.07 (in red, the hour for which the UTCI heat maps are generated remains the same for all following graphs)	72
Figure 55 Difference in UTCI of scenarios 2,3,4 to scenario 1 for point 3 over 24 hours on 20.07 (in red is the hour for which the UTCI heat maps are generated)	73
Figure 56 Location of study points in scenario 5A (left) and scenario 5B (right)	73
Figure 57 Difference in UTCI between scenarios 5A-1 for different study points.....	74
Figure 58 Difference in UTCI between scenarios 5B-4 for different study points.....	75
Figure 59: Salvati, Coch Roura et al. 2016 - Urban heat island prediction.jpg [37].....	77

8. List of tables

Table 1 PET and UTCI values range concerning thermal stress [41]	21
Table 2 Floor-to-floor height of the buildings under study (Appendix A)	44
Table 3 Floor-to-floor height after vertical densification (Appendix A).....	44
Table 4 Glazing ratio of the five buildings under study (Appendix A).....	45
Table 5 Glazing ratio of the five buildings under study after the addition of one floor (Appendix A)	45
Table 6 Further detailed parameters of fenestration for the buildings under study (Appendix A)	45
Table 7 Asphalt albedo for different years of construction [81, p. 173]	48
Table 8 Albedo values for the building roofs in the study area used for the parametric flow	49
Table 9 Wall albedo values for the buildings in the study area	50
Table 10 Hourly Anthropogenic heat for the city of Toledo in July [92]	55
Table 11 Information concerning added trees (Appendix B)	56
Table 12 Details for the newly added trees (Appendix B)	58
Table 13 UTCI values in °C for all scenarios for point 1 and their difference	70

Appendix A

Removed for publication

Appendix B

Removed for publication

9. References

- [1] *Urban population | Data*. [Online]. Available: <https://data.worldbank.org/indicator/SP.URB.TOTL> (accessed: Jan. 20 2022).
- [2] *Urban population (% of total population) | Data*. [Online]. Available: <https://data.worldbank.org/indicator/SP.URB.TOTL.IN.ZS> (accessed: Jan. 20 2022).
- [3] *World urban population 2021 - StatisticsTimes.com*. [Online]. Available: <https://statisticstimes.com/demographics/world-urban-population.php> (accessed: Aug. 19 2022).
- [4] *Urban population (Germany % of total population) - Germany | Data*. [Online]. Available: https://data.worldbank.org/indicator/SP.URB.TOTL.IN.ZS?locations=DE&most_recent_value_desc=false (accessed: Jan. 20 2022).
- [5] *Urban population growth (annual %) - Germany | Data*. [Online]. Available: https://data.worldbank.org/indicator/SP.URB.GROW?most_recent_value_desc=false&locations=DE (accessed: Aug. 19 2022).
- [6] World Bank Group, "World Bank Document: CITIES IN EUROPE AND CENTRAL ASIA, GERMANY," [Online]. Available: <https://documents1.worldbank.org/curated/en/924911511933682347/pdf/121726-BRI-P154478-PUBLIC-Germany-Snapshot-Print.pdf>
- [7] M. Amer, A. Mustafa, J. Teller, S. Attia, and S. Reiter, "A methodology to determine the potential of urban densification through roof stacking," *Sustainable Cities and Society*, vol. 35, pp. 677–691, 2017, doi: 10.1016/j.scs.2017.09.021.
- [8] M. Vuckovic *et al.*, "Generation and evaluation of alternative urban densification scenarios," 2017. [Online]. Available: <https://www.semanticscholar.org/paper/Generation-and-evaluation-of-alternative-urban-Vuckovic-Mahdavi/b0743a8cffe8fd23d175d9666c0574feffb4edfb>
- [9] K. I. Abdrabo *et al.*, "A Methodological Approach towards Sustainable Urban Densification for Urban Sprawl Control at the Microscale: Case Study of Tanta, Egypt," *Sustainability*, vol. 13, no. 10, p. 5360, 2021, doi: 10.3390/su13105360.
- [10] A.-F. Marique and S. Reiter, "Retrofitting the Suburbs: Insulation, Density, Urban Form and Location," *EMSD*, vol. 3, no. 2, p. 138, 2014, doi: 10.5296/emsd.v3i2.6589.
- [11] Estefania Tapias Pedraza Antje Kunze, Giuseppe Roccasalva, Gerhard Schmitt, "Design Decision-Making - Volume 1 - Computation and Performance: Best Practices for Urban Densification," vol. 1. [Online]. Available: https://www.google.com/url?sa=t&rct=j&q=&esrc=s&source=web&cd=&cad=rja&uact=8&ved=2ahUKEwiY66iundX5AhWg8LsIHbOjAB0QFnoECAoQAQ&url=https%3A%2F%2Fwww.researchgate.net%2Fpublication%2F281232718_A_decision-making_support_process_using_microclimate_analysis_methods_and_parametric_models_for_optimizing_urban_climate_comfort&usg=AOvVaw1-y36KhrBw25xMTC1DEL5F
- [12] S. F. Erick and R. S. Marisol, "Spatial suitability for urban sustainable densification in a borderland city," *J. Geogr. Reg. Plann.*, vol. 10, no. 10, pp. 266–277, 2017, doi: 10.5897/JGRP2017.0648.
- [13] R. Emmanuel and K. Steemers, "Connecting the realms of urban form, density and microclimate," *Building Research & Information*, vol. 46, no. 8, pp. 804–808, 2018, doi: 10.1080/09613218.2018.1507078.
- [14] M. Pecelj *et al.*, "Temporal Analysis of Urban-Suburban PET, mPET and UTCI Indices in Belgrade (Serbia)," *Atmosphere*, vol. 12, no. 7, p. 916, 2021, doi: 10.3390/atmos12070916.

- [15] M. Vuckovic, T. Tötzer, R. Stollnberger, and W. Loibl, "Urban transformation and heat island: Potential of urban design alternatives to mitigate the effects of urban overheating in Austrian cities," *J. Urb. Env.*, pp. 3–14, 2020, doi: 10.34154/2020-JUE-0101-03-14/auraass.
- [16] W. Loibl, M. Vuckovic, G. Etmnan, M. Ratheiser, S. Tschannett, and D. Österreicher, "Effects of Densification on Urban Microclimate—A Case Study for the City of Vienna," *Atmosphere*, vol. 12, no. 4, p. 511, 2021, doi: 10.3390/atmos12040511.
- [17] S. Chapman, M. Thatcher, A. Salazar, J. E. M. Watson, and C. A. McAlpine, "The Effect of Urban Density and Vegetation Cover on the Heat Island of a Subtropical City," *Journal of Applied Meteorology and Climatology*, vol. 57, no. 11, pp. 2531–2550, 2018, doi: 10.1175/JAMC-D-17-0316.1.
- [18] N. Debbage and J. M. Shepherd, "The urban heat island effect and city contiguity," *Computers, Environment and Urban Systems*, vol. 54, pp. 181–194, 2015, doi: 10.1016/j.compenvurbsys.2015.08.002.
- [19] U. Berardi and Y. Wang, "The Effect of a Denser City over the Urban Microclimate: The Case of Toronto," *Sustainability*, vol. 8, no. 8, p. 822, 2016, doi: 10.3390/su8080822.
- [20] D. Erlström, "Outdoor thermal comfort in Drottninghög, Helsingborg.: A study on the effects of urban densification in a warmer climate," Bachelor Thesis, Lund University, Sweden, 2020. [Online]. Available: <https://lup.lub.lu.se/student-papers/search/publication/9022197>
- [21] J. Artés, G. Wadel, and N. Martí, "Vertical Extension and Improving of Existing Buildings," *TOBCTJ*, vol. 11, no. 1, pp. 83–94, 2017, doi: 10.2174/1874836801711010083.
- [22] M. Vuckovic *et al.*, "Generation and evaluation of alternative urban densification scenarios," 2017. [Online]. Available: <https://www.semanticscholar.org/paper/Generation-and-evaluation-of-alternative-urban-Vuckovic-Mahdavi/b0743a8cffe8fd23d175d9666c0574feffb4edfb>
- [23] Setaih Khalid, Hamza Neveen, Townshend Tim, "Assessment of outdoor thermal comfort in urban microclimate in hot arid areas," *13th Conference of International Building Performance Simulation Association*. [Online]. Available: https://www.researchgate.net/publication/262380136_Assessment_of_Outdoor_Thermal_Comfort_in_Urban_Microclimate_in_Hot_Arid_Areas
- [24] A. Salvati, M. Kolokotroni, A. Kotopouleas, R. Watkins, R. Giridharan, and M. Nikolopoulou, "Impact of reflective materials on urban canyon albedo, outdoor and indoor microclimates," *Building and Environment*, vol. 207, p. 108459, 2022, doi: 10.1016/j.buildenv.2021.108459.
- [25] J. Yuan, K. Emura, and C. Farnham, "Is urban albedo or urban green covering more effective for urban microclimate improvement?: A simulation for Osaka," *Sustainable Cities and Society*, vol. 32, pp. 78–86, 2017, doi: 10.1016/j.scs.2017.03.021.
- [26] F. Salata, I. Golasi, A. d. L. Vollaro, and R. d. L. Vollaro, "How high albedo and traditional buildings' materials and vegetation affect the quality of urban microclimate. A case study," *Energy and Buildings*, vol. 99, pp. 32–49, 2015, doi: 10.1016/j.enbuild.2015.04.010.
- [27] A. Chatzidimitriou and S. Yannas, "Microclimate development in open urban spaces: The influence of form and materials," *Energy and Buildings*, vol. 108, pp. 156–174, 2015, doi: 10.1016/j.enbuild.2015.08.048.

- [28] J. Yang, Z.-H. Wang, and K. E. Kaloush, "Environmental impacts of reflective materials: Is high albedo a 'silver bullet' for mitigating urban heat island?," *Renewable and Sustainable Energy Reviews*, vol. 47, pp. 830–843, 2015, doi: 10.1016/j.rser.2015.03.092.
- [29] N. L. Alchapar and E. N. Correa, "The use of reflective materials as a strategy for urban cooling in an arid "OASIS" city," *Sustainable Cities and Society*, vol. 27, pp. 1–14, 2016, doi: 10.1016/j.scs.2016.08.015.
- [30] S. Erlwein, T. Zölch, and S. Pauleit, "Regulating the microclimate with urban green in densifying cities: Joint assessment on two scales," *Building and Environment*, vol. 205, p. 108233, 2021, doi: 10.1016/j.buildenv.2021.108233.
- [31] S. HosseiniHaghighi, F. Izadi, R. Padsala, and U. Eicker, "Using Climate-Sensitive 3D City Modeling to Analyze Outdoor Thermal Comfort in Urban Areas," *IJGI*, vol. 9, no. 11, p. 688, 2020, doi: 10.3390/ijgi9110688.
- [32] Andrew Coutts and Nigel Tapper, "Trees for a cool city: Guidelines for optimised tree placement: The design of the public realm to enhance urban microclimates (Project B3.2)," 2017. [Online]. Available: https://ipweaq.intersearch.com.au/ipweaqjspui/bitstream/1/3886/1/Trees-for-a-cool-city_Guidelines-for-optimised-tree-placement.pdf
- [33] E. Johansson and M. W. Yahia, "Evaluation of the effect of densification of the built environment on outdoor thermal comfort in warm-humid Dar es Salaam, Tanzania," *9th International Conference on Urban Climatology - Toulouse, France*, 2015. [Online]. Available: <https://portal.research.lu.se/en/publications/evaluation-of-the-effect-of-densification-of-the-built-environment>
- [34] B. Bueno, L. Norford, J. Hidalgo, and G. Pigeon, "The urban weather generator," *Journal of Building Performance Simulation*, vol. 6, no. 4, pp. 269–281, 2013, doi: 10.1080/19401493.2012.718797.
- [35] Aiko Nakano, Bruno Bueno, Leslie Norford, Christoph F Reinhart, "Urban Weather Generator - a Novel Workflow for Integrating Urban Heat Island Effect Within Urban Design Process." 14th Conference of International Building Performance Simulation Association," Dec. 2015. [Online]. Available: https://www.researchgate.net/publication/316819351_Urban_Weather_Generator_-_a_Novel_Workflow_for_Integrating_Urban_Heat_Island_Effect_within_Urban_Design_Process
- [36] G. Xu, J. Li, Y. Shi, X. Feng, and Y. Zhang, "Improvements, extensions, and validation of the Urban Weather Generator (UWG) for performance-oriented neighborhood planning," *Urban Climate*, vol. 45, p. 101247, 2022, doi: 10.1016/j.uclim.2022.101247.
- [37] A. Salvati, H. Coch Roura, and C. Cecere, "Urban heat island prediction in the mediterranean context: an evaluation of the urban weather generator model," *ACE: Architecture, City and Environment*, vol. 11, no. 32, pp. 135–156, 2016, doi: 10.5821/ace.11.32.4836.
- [38] M. Moradi *et al.*, "The Vertical City Weather Generator (VCWG v1.3.2)," *Geosci. Model Dev.*, vol. 14, no. 2, pp. 961–984, 2021, doi: 10.5194/gmd-14-961-2021.
- [39] Grasshopper Docs, *Dragonfly - Addon for Grasshopper | Grasshopper Docs*. [Online]. Available: <http://grasshopperdocs.com/addons/dragonfly.html> (accessed: May 6 2022).
- [40] Andreas Matzarakis, Dominik Fröhlich, Marcel Gangwisch, Christine Ketterer, Andreas Peer, "Developments and applications of thermal indices in urban structures by RayMan and SkyHelios model," 2015. [Online]. Available: https://www.researchgate.net/publication/281130221_Developments_and_applications_of_thermal_indices_in_urban_structures_by_RayMan_and_SkyHelios_model

- [41] A. Matzarakis, S. Muthers, and F. Rutz, "Application and comparison of UTCI and PET in temperate climate conditions," *Finisterra*, vol. 49, no. 98, 2015, doi: 10.18055/Finis6453.
- [42] Yasser Ibrahim, Tristan Kershaw, Paul Shepherd, *Improvement of the Ladybug-tools microclimate workflow: A verification study*. [Online]. Available: https://www.researchgate.net/publication/347370637_Improvement_of_the_Ladybug-tools_microclimate_workflow_A_verification_study (accessed: Jan. 21 2022).
- [43] P. K. Cheung and C. Y. Jim, "Comparing the cooling effects of a tree and a concrete shelter using PET and UTCI," *Building and Environment*, vol. 130, pp. 49–61, 2018, doi: 10.1016/j.buildenv.2017.12.013.
- [44] A. Urban and J. Kysely, "Comparison of UTCI with other thermal indices in the assessment of heat and cold effects on cardiovascular mortality in the Czech Republic," *International journal of environmental research and public health*, vol. 11, no. 1, pp. 952–967, 2014, doi: 10.3390/ijerph110100952.
- [45] R. K. Theresa Fink, "Integrated Parametric Urban Design in Grasshopper Rhinoceros 3D," Data - CITY INFORMATION MODELLING AND GIS - Volume 3 - eCAADe 37 / SIGraDi 23.
- [46] B. Kos and L. Snoj, "On using Grasshopper add-on for CAD to MCNP conversion," [Online]. Available: https://www.researchgate.net/profile/Bor-Kos-2/publication/306912636_On_using_Grasshopper_add-on_for_CAD_to_MCNP_conversion/links/57cf138d08ae057987ac06fd/On-using-Grasshopper-add-on-for-CAD-to-MCNP-conversion.pdf
- [47] A. Eltaweel and Y. Su, "Controlling venetian blinds based on parametric design; via implementing Grasshopper's plugins: A case study of an office building in Cairo," *Energy and Buildings*, vol. 139, pp. 31–43, 2017, doi: 10.1016/j.enbuild.2016.12.075.
- [48] Mostapha Sadeghipour Roudsari, Michelle Pak, "LADYBUG A PARAMETRIC ENVIRONMENTAL PLUGIN FOR GRASSHOPPER TO HELP DESIGNERS CREATE AN ENVIRONMENTALLY-CONSCIOUS DESIGN," [Online]. Available: http://www.ibpsa.org/proceedings/bs2013/p_2499.pdf
- [49] N. Perera, "Urban Heat Island Minimisation, Local Climate Zones and Parametric Optimisation: A "Grasshopper" Based Model: 5th International Conference on Countermeasures to Urban Heat Islands (IC2UHI).," *5th International Conference on Countermeasures to Urban Heat Islands (IC2UHI)*, 2019. [Online]. Available: https://www.academia.edu/download/61562879/id121_full_paper20191219-90972-hz3yy3.pdf
- [50] T. M. Kamel, "A new comprehensive workflow for modelling outdoor thermal comfort in Egypt," *Solar Energy*, vol. 225, pp. 162–172, 2021, doi: 10.1016/j.solener.2021.07.029.
- [51] *Ladybug Tools | Home Page*. [Online]. Available: <https://www.ladybug.tools/> (accessed: May 21 2022).
- [52] M. H. Ata Chokhachian, "PANDO: Parametric Tool for Simulating Soil-Plant-Atmosphere of Tree Canopies in Grasshopper," 2020. [Online]. Available: <http://simaud.org/2020/proceedings/105.pdf>
- [53] Food4Rhino, *PANDO*. [Online]. Available: <https://www.food4rhino.com/en/app/pando> (accessed: Jun. 10 2022).
- [54] Y. Ibrahim, T. Kershaw, P. Shepherd, and D. Coley, "On the Optimisation of Urban form Design, Energy Consumption and Outdoor Thermal Comfort Using a Parametric Workflow in a Hot Arid Zone," *Energies*, vol. 14, no. 13, p. 4026, 2021, doi: 10.3390/en14134026.
- [55] *Boundary representation - Wikipedia*. [Online]. Available: https://en.m.wikipedia.org/wiki/Boundary_representation (accessed: Jun. 8 2022).

- [56] Grasshopper Docs, *Honeybee - Addon for Grasshopper | Grasshopper Docs*. [Online]. Available: <https://grasshopperdocs.com/addons/honeybee.html> (accessed: May 27 2022).
- [57] Grasshopper Docs, *Ladybug - Addon for Grasshopper | Grasshopper Docs*. [Online]. Available: <https://grasshopperdocs.com/addons/ladybug.html> (accessed: Jun. 10 2022).
- [58] Meteonorm (de), *Intro - Meteonorm (de)*. [Online]. Available: <https://meteonorm.com/> (accessed: Feb. 4 2022).
- [59] *Energy Plus - How to create and use epw and ddy files?* [Online]. Available: <https://unmethours.com/question/2393/energy-plus-how-to-create-and-use-epw-and-ddy-files/> (accessed: Jun. 14 2022).
- [60] Ladybug Tools | Forum, *Tree coverage ratio calculation - grasshopper / dragonfly - Ladybug Tools | Forum*. [Online]. Available: <https://discourse.ladybug.tools/t/tree-coverage-ratio-calculation/18301/3> (accessed: Jun. 15 2022).
- [61] Grasshopper Docs, *Grasshopper Maths - Addon for Grasshopper | Grasshopper Docs*. [Online]. Available: <https://grasshopperdocs.com/addons/grasshopper-maths.html> (accessed: Jun. 17 2022).
- [62] bayernatlas.de, *BayernAtlas*. [Online]. Available: <https://v.bayern.de/HTLyg> (accessed: May 20 2022).
- [63] IHK_Standortportal Bayern, "Information System Bavaria PDF Export: Region Profile: Kempten (Allgäu)," May. 2022. [Online]. Available: <https://standortportal.bayern/en/BayStandorte/Schwaben/KemptenAllgaeu.html>
- [64] S. Stadt Kempten (Allgäu), *Flächennutzungsplan mit integriertem Landschaftsplan: 210330_FNP_Gesamt_kat_2017red.jpg (9018x7537)*. [Online]. Available: https://www.kempten.de/stadtkempten/img/210330_FNP_Gesamt_kat_2017red.jpg (accessed: May 19 2022).
- [65] J. Billwitz, *Kempten im Allgäu - Stadtplan*. [Online]. Available: <https://maps.kempten.de/> (accessed: May 9 2022).
- [66] *Climate Kempten (Allgäu): Weather, climate table & climate diagram for Kempten (Allgäu)*. [Online]. Available: <https://de.climate-data.org/europa/deutschland/bayern/kempten-allgaeu-23177/> (accessed: May 9 2022).
- [67] M. Vellei, M. Herrera, D. Fosas, and S. Natarajan, "The influence of relative humidity on adaptive thermal comfort," *Building and Environment*, vol. 124, pp. 171–185, 2017, doi: 10.1016/j.buildenv.2017.08.005.
- [68] Statista, *Monthly sunshine hours Germany 2020/2021 | Statista*. [Online]. Available: <https://www.statista.com/statistics/982758/average-sunshine-hours-germany/> (accessed: May 9 2022).
- [69] *BayBO: Art. 45 common rooms - citizen service*. [Online]. Available: <https://www.gesetze-bayern.de/Content/Document/BayBO-45> (accessed: Feb. 7 2022).
- [70] *TABULA WebTool*. [Online]. Available: <https://webtool.building-typology.eu/?c=de#bd> (accessed: Feb. 7 2022).
- [71] *Ceiling elements according to DIN EN 1520 - Beton.org*. [Online]. Available: <https://www.beton.org/wissen/wirtschaftshochbau/deckenelemente-nach-din-en-1520/> (accessed: Feb. 7 2022).
- [72] *Google Earth*. [Online]. Available: earth.google.com (accessed: May 29 2022).
- [73] ConstruPM, *EDGE Green Buildings: what's window to wall ratio? - ConstruPM*. [Online]. Available: http://mundobim.com/construpm/edge-green-buildings-whats-window-to-wall-ratio/#google_vignette (accessed: May 24 2022).
- [74] Landesinstitut für Bauwesen des Landes Nord rhein-Westfalen (LB), "Planungshilfe Energiesparendes Bauen," [Online]. Available: https://www.stmb.bayern.de/assets/stmi/buw/hochbau/iaa2_energetischesanierung_planungshilfe_energiesparendes_bauen.pdf

- [75] Umwelt + Klimapakt Bayern, *Effiziente Energienutzung bei Büro- und Verwaltungsgebäuden - IZU*. [Online]. Available: https://www.umweltpakt.bayern.de/energie_klima/fachwissen/167/effiziente-energienutzung-bei-buero-verwaltungsgebaeuden (accessed: May 27 2022).
- [76] *St. Anton Kempten - Home*. [Online]. Available: <https://www.st-anton-ke.de/> (accessed: May 27 2022).
- [77] J.-M. Almodovar-Melendo, J.-M. Cabeza-Lainez, and I. Rodriguez-Cunill, "Lighting Features in Historical Buildings: Scientific Analysis of the Church of Saint Louis of the Frenchmen in Sevilla," *Sustainability*, vol. 10, no. 9, p. 3352, 2018, doi: 10.3390/su10093352.
- [78] A. Zhivov and R. Lohse, *Deep Energy Retrofit*. Cham: Springer International Publishing, 2020.
- [79] *St. Anton Kempten - Maria help in the calibration*. [Online]. Available: <https://www.st-anton-ke.de/maria-hilf-eich.php> (accessed: May 20 2022).
- [80] *Hochschule Kempten history*. [Online]. Available: <https://www.hs-kempten.de/hochschule/ueber-uns/geschichte> (accessed: Feb. 7 2022).
- [81] S. Sen and J. Roesler, "Aging albedo model for asphalt pavement surfaces," *Journal of Cleaner Production*, vol. 117, pp. 169–175, 2016, doi: 10.1016/j.jclepro.2016.01.019.
- [82] J. R. Simpson and E. G. McPherson, "The effects of roof albedo modification on cooling loads of scale model residences in Tucson, Arizona," *Energy and Buildings*, vol. 25, no. 2, pp. 127–137, 1997, doi: 10.1016/S0378-7788(96)01002-X.
- [83] H. Taha, D. Sailor, and H. Akbari, "High-albedo materials for reducing building cooling energy use," 1992.
- [84] Klaus Grasser / Gernot Minke, Ed., *Building with Pumice: A Publication of Deutsches Zentrum für Entwicklungstechnologien -GATE in: Deutsche Gesellschaft für Technische Zusammenarbeit (GTZ) GmbH - 1990*. Düsseldorf, Braunschweig: August Bagel Verlag; Friedr. Vieweg + Sohn, 1973.
- [85] N. L. Alchapar and E. N. Correa, "Comparison of the performance of different facade materials for reducing building cooling needs," in *Eco-Efficient Materials for Mitigating Building Cooling Needs*: Elsevier, 2015, pp. 155–194.
- [86] A. Misni, G. Baird, and P. Allan, "The Effect of Landscaping on the Thermal Performance of Housing," *IRSPSD International*, vol. 1, no. 1, pp. 29–48, 2013, doi: 10.14246/irspsd.1.1_29.
- [87] A. Salvati, M. Palme, and L. Inostroza, "Key Parameters for Urban Heat Island Assessment in A Mediterranean Context: A Sensitivity Analysis Using the Urban Weather Generator Model," *IOP Conf. Ser.: Mater. Sci. Eng.*, vol. 245, p. 82055, 2017, doi: 10.1088/1757-899X/245/8/082055.
- [88] Grasshopper Docs, *Reference EPW Parameters - Dragonfly - Component for Grasshopper | Grasshopper Docs*. [Online]. Available: <https://grasshopperdocs.com/components/dragonfly/referenceEPWParameters.html> (accessed: Feb. 4 2022).
- [89] *infra3D-Client*. [Online]. Available: <https://idp.infra3d.ch/idp/profile/SAML2/Redirect/SSO?execution=e2s1> (accessed: Feb. 4 2022).
- [90] Ladybug Tools | Forum, *UWG failed to run - ladybug-tools - Ladybug Tools | Forum*. [Online]. Available: <https://discourse.ladybug.tools/t/uwg-failed-to-run/16957/4> (accessed: Jun. 10 2022).
- [91] *Web GIS Mapping Software | ArcGIS Online*. [Online]. Available: <https://www.esri.com/en-us/arcgis/products/arcgis-online/overview#analyze-data> (accessed: Aug. 18 2022).

- [92] D. J. Sailor, M. Georgescu, J. M. Milne, and M. A. Hart, "Development of a national anthropogenic heating database with an extrapolation for international cities," *Atmospheric Environment*, vol. 118, pp. 7–18, 2015, doi: 10.1016/j.atmosenv.2015.07.016.
- [93] Grasshopper Docs, *Traffic Parameters - Dragonfly - Component for Grasshopper / Grasshopper Docs*. [Online]. Available: <https://grasshopperdocs.com/components/dragonfly/trafficParameters.html> (accessed: Feb. 4 2022).
- [94] *Toledo, Ohio Population 2022 (Demographics, Maps, Graphs)*. [Online]. Available: <https://worldpopulationreview.com/us-cities/toledo-oh-population> (accessed: Feb. 4 2022).
- [95] *Kempton (Kempton (Allgäu), Bavaria, Germany) - Population Statistics, Charts, Map, Location, Weather and Web Information*. [Online]. Available: https://www.citypopulation.de/en/germany/bayern/kempton_allg%C3%A4u_/09763000__kempton_allg%C3%A4u_/ (accessed: Feb. 4 2022).
- [96] T. Zölch, J. Maderspacher, C. Wamsler, and S. Pauleit, "Using green infrastructure for urban climate-proofing: An evaluation of heat mitigation measures at the micro-scale," *Urban Forestry & Urban Greening*, vol. 20, pp. 305–316, 2016, doi: 10.1016/j.ufug.2016.09.011.
- [97] C.-M. Hsieh, "Effects of tree shading and transpiration on building cooling energy use," *Energy and Buildings*, vol. 159, pp. 382–397, 2018, doi: 10.1016/j.enbuild.2017.10.045.
- [98] C. Wu, Q. Xiao, and E. G. McPherson, "A method for locating potential tree-planting sites in urban areas: A case study of Los Angeles, USA," *Urban Forestry & Urban Greening*, vol. 7, no. 2, pp. 65–76, 2008, doi: 10.1016/j.ufug.2008.01.002.
- [99] A. Middel, N. Chhetri, and R. Quay, "Urban forestry and cool roofs: Assessment of heat mitigation strategies in Phoenix residential neighborhoods," *Urban Forestry & Urban Greening*, vol. 14, no. 1, pp. 178–186, 2015, doi: 10.1016/j.ufug.2014.09.010.
- [100] *Temperatures - Dry Bulb/Web Bulb/Dew Point*. [Online]. Available: https://www.weather.gov/source/zhu/ZHU_Training_Page/definitions/dry_wet_bulb_definition/dry_wet_bulb.html (accessed: Feb. 19 2022).
- [101] H. Li, "Impacts of Pavement Strategies on Human Thermal Comfort," in *Pavement Materials for Heat Island Mitigation*: Elsevier, 2016, pp. 281–306.
- [102] *Germany Sunrise Sunset Times*. [Online]. Available: <https://sunrise.map-logs.com/germany.29.html?year=2015> (accessed: Jul. 20 2022).
- [103] D. A. Sachindra, A. W. M. Ng, S. Muthukumaran, and B. J. C. Perera, "Impact of climate change on urban heat island effect and extreme temperatures: a case-study," *Q.J.R. Meteorol. Soc.*, vol. 142, no. 694, pp. 172–186, 2016, doi: 10.1002/qj.2642.
- [104] M. A. Rahman *et al.*, "Spatial and temporal changes of outdoor thermal stress: influence of urban land cover types," *Scientific reports*, vol. 12, no. 1, p. 671, 2022, doi: 10.1038/s41598-021-04669-8.
- [105] H. Lee, H. Mayer, and L. Chen, "Contribution of trees and grasslands to the mitigation of human heat stress in a residential district of Freiburg, Southwest Germany," *Landscape and Urban Planning*, vol. 148, pp. 37–50, 2016, doi: 10.1016/j.landurbplan.2015.12.004.
- [106] Vuckovic, Loibl, Tötzer, and Stollnberger, "Potential of Urban Densification to Mitigate the Effects of Heat Island in Vienna, Austria," *Environments*, vol. 6, no. 7, p. 82, 2019, doi: 10.3390/environments6070082.
- [107] Wolfgang Loibl, Ghazal Etminan, Doris Österreicher, Matthias Ratheiser, Romana Stollnberger, Simon Tschannett, Tanja Tötzer, Milena Vuckovic, Karoline Walal, "Urban Densification and Urban Climate Change – Assessing Interaction

through Densification Scenarios and Climate Simulations: Perfect smart cities vs. real emotional cities : proceedings of the 24th International Conference on Urban Planning, Regional Development and Information Society : Tagungsband : 2-4 April 2019, Karlsruhe Institute of Technology, Karlsruhe,” (in eng;ger), 2019. [Online]. Available: <https://www.semanticscholar.org/paper/Urban-Densification-and-Urban-Climate-Change-%E2%80%93and-Loibl-Etminan/4f73d3829609d0f515e06b6fa68210a98dd68039>

- [108] S. Erlwein and S. Pauleit, “Trade-Offs between Urban Green Space and Densification: Balancing Outdoor Thermal Comfort, Mobility, and Housing Demand,” *UP*, vol. 6, no. 1, pp. 5–19, 2021, doi: 10.17645/up.v6i1.3481.
- [109] O. M. Galal, H. Mahmoud, and D. Sailor, “Impact of evolving building morphology on microclimate in a hot arid climate,” *Sustainable Cities and Society*, vol. 54, p. 102011, 2020, doi: 10.1016/j.scs.2019.102011.
- [110] S. Coccolo, D. Pearlmutter, J. Kaempf, and J.-L. Scartezzini, “Thermal Comfort Maps to estimate the impact of urban greening on the outdoor human comfort,” *Urban Forestry & Urban Greening*, vol. 35, pp. 91–105, 2018, doi: 10.1016/j.ufug.2018.08.007.
- [111] N. Meili *et al.*, “Tree effects on urban microclimate: Diurnal, seasonal, and climatic temperature differences explained by separating radiation, evapotranspiration, and roughness effects,” *Urban Forestry & Urban Greening*, vol. 58, p. 126970, 2021, doi: 10.1016/j.ufug.2020.126970.
- [112] D. D. Milošević, I. V. Bajšanski, and S. M. Savić, “Influence of changing trees locations on thermal comfort on street parking lot and footways,” *Urban Forestry & Urban Greening*, vol. 23, pp. 113–124, 2017, doi: 10.1016/j.ufug.2017.03.011.