

LETTER

Woody plant phylogenetic diversity supports nature's contributions to people but is at risk from human population growth

T. Jonathan Davies^{1,2} | Olivier Maurin³ | Kowiyou Yessoufou⁴ |
 Barnabas H. Daru⁵ | Bezeng S. Bezeng⁴ | Ledile T. Mankga⁶ | Hanno Schaefer⁷ |
 Wilfried Thuiller⁸ | Michelle van der Bank²

¹Biodiversity Research Centre, University of British Columbia, Vancouver, British Columbia, Canada

²African Centre for DNA Barcoding, Department of Botany & Plant Biotechnology, University of Johannesburg, Johannesburg, South Africa

³Herbarium, Royal Botanic Gardens KEW, Richmond, UK

⁴Department of Geography, Environmental Management and Energy Studies, University of Johannesburg, Johannesburg, South Africa

⁵Department of Life Sciences, Texas A&M University-Corpus Christi, Corpus Christi, Texas, USA

⁶Department of Life and Consumer Sciences, University of South Africa, Science Campus, Florida, South Africa

⁷Technische Universitaet Muenchen, Plant Biodiversity Research, Freising, Germany

⁸Univ. Grenoble Alpes, Univ. Savoie Mont Blanc, CNRS, LECA, Laboratoire d'Écologie Alpine, F-38000 Grenoble, France

Correspondence

T. Jonathan Davies, Biodiversity Research Centre, University of British Columbia, 2212 Main Mall, Vancouver, BC V6T 1Z4, Canada.

Email: j.davies@ubc.ca

Abstract

The Tree of Life—phylogeny—provides a powerful tool for understanding the processes regulating life's diversity. Conserving the branches on the Tree of Life might also have practical benefits. Using a comprehensive phylogeny of southern African woody trees and shrubs, and structural equation modeling, we show that human population density correlates closely with not only the richness of woody plants in a region but also their evolutionary relatedness. Further, we demonstrate that more phylogenetically diverse species assemblages support a greater diversity of ecosystem goods and services. Our results suggest that people in Africa may gain material benefits from inhabiting regions that support high phylogenetic diversity of woody plants. However, the correlation between human population and woody plant diversity creates a tension between people and biodiversity, which could threaten the contributions to people provided by intact and phylogenetically diverse ecosystems.

KEYWORDS

ecosystem services, human population density, IUCN Red List, nature's contributions to people, phylogenetic diversity, species richness, tree of life

This is an open access article under the terms of the [Creative Commons Attribution](https://creativecommons.org/licenses/by/4.0/) License, which permits use, distribution and reproduction in any medium, provided the original work is properly cited.

© 2022 The Authors. Conservation Letters published by Wiley Periodicals LLC.

1 | INTRODUCTION

Human population has increased dramatically over the last 200 years; the distribution of people, however, is highly uneven. In 2008, the urban population outnumbered the rural population for the first time (United Nations, 2011), and in much of the developed world the human population is stable or decreasing. In contrast, although urbanizing rapidly, the human population in sub-Saharan Africa is still increasing, and remains predominantly rural (UNICEF, 2012). Much of the human population in sub-Saharan Africa depends directly or indirectly on the goods and services provided by biodiversity (Egoh et al., 2012). However, many of these services are being degraded through habitat loss and transformation, exacerbated by rapid urbanization, agricultural expansion, “land grabbing” by foreign nations, and climate change (Egoh et al., 2012; Malherbe et al., 2019). Poor and rural communities tend to be most impacted by losses of ecosystem services as they frequently lack alternatives (United Nation Economic Commission for Africa, 2010; Egoh et al., 2012).

An increasing body of evidence suggests that more diverse ecosystems contribute more to the provisioning of ecosystem services (Hooper et al., 2012). The link between species richness and ecosystem function has been the focus of much attention (Hooper et al., 2005; Liang et al., 2016; Duffy et al., 2017), and there is evidence suggesting that more diverse ecosystems also support a greater diversity of ecosystem functions (Hector & Bagchi, 2007; Isbell et al., 2011; Gamfeldt et al., 2013; Perkins et al., 2015). However, the correlation between the provisioning of ecosystem services and species richness at the landscape scale is often mixed (Egoh et al., 2009; O’Farrell et al., 2010; der Plas et al., 2018), and there may be trade-offs between ecosystem functions or services (Gamfeldt et al., 2013).

More direct measure of species differences that capture variation in functional traits are suggested to be better predictors of ecosystem processes (Díaz et al., 2007; de Bello et al., 2010). However, we are often limited in the trait data available for species and there is likely no single small set of traits that can explain variation across multiple ecosystem functions (van der Plas et al., 2020). Phylogenetic diversity—the summed branch lengths on a phylogenetic tree—provides a more inclusive metric for quantifying species differences (Faith, 1992). Because we expect species to diverge over time, the set of species with higher phylogenetic diversity is predicted to capture greater feature diversity.

Forest et al. (2007) demonstrated that greater phylogenetic diversity might translate into a greater diversity of ecosystem services using data on medicinal plants in the Fynbos biome, South Africa. More recent work has

indicated that the relationship between phylogenetic diversity and the diversity of ecosystem services and goods represented extends across angiosperms (Molina-Venegas et al., 2021). However, whether people gain direct material benefits from such relationships depends on the co-occurrence of people and floras supporting high phylogenetic diversity.

Here, we evaluate the relationship between woody plant phylogenetic diversity, provisioning of ecosystem goods and services, and human population density in southern Africa. Using a comprehensive phylogeny for the woody trees and shrubs of southern Africa (Figure 1), we (1) quantify the spatial coincidence between rural human population density and woody plant phylogenetic diversity, and (2) test whether locations that support a high phylogenetic diversity of woody plants also support a greater diversity of ecosystem services and goods.

2 | METHODS

Over a 6-year collection effort, we sampled woody trees and shrubs (defined as woody plants with stems or pseudostems > 0.5 m in height) across southern Africa (Appendix S1). We sequenced the core plant barcodes (*rbcLa* and *matK*) from sampled material, and merged these data with matching barcode sequence data in GenBank from species native to the region. We then used the merged sequence matrix to reconstruct a comprehensive phylogeny of the southern African woody flora (Supplemental Methods S1). Branch lengths were calibrated in millions of years using Bayesian MCMC in BEAST v.1.4.8 and 28 fossil calibrations (Table S1). Voucher specimen information and GenBank accession numbers are listed in Appendix S2.

For each species, we collated data on 11 separate uses: firewood and charcoal, carving, building and structural, spiritual, cultural, food, ornamental, forage and fodder, shade, chemical compounds, and medicinal, plus threat category from the IUCN Red Data List of Threatened Species (<http://redlist.sanbi.org/>). All data and source references are listed in Appendix S3.

Species distribution data were extracted from Coates Palgrave et al. (2002) and Van Wyk et al. (2011), and overlaid on a 0.5° × 0.5° grid (approximately 50 km × 50 km). For each grid cell, we then extracted data on actual evapotranspiration, AET (data set GNV183; <http://www.grid.unep.ch/data/>), as a proxy for productivity, variance in elevation (data set GTOPO30; <http://www1.gsi.go.jp/geowww/globalmap-gsi/gtopo30/gtopo30.html>), as a proxy for topographic heterogeneity, and human population density (data set GPWv3 <http://sedac.ciesin.columbia.edu/data/collection/gpw-v3>). We excluded population

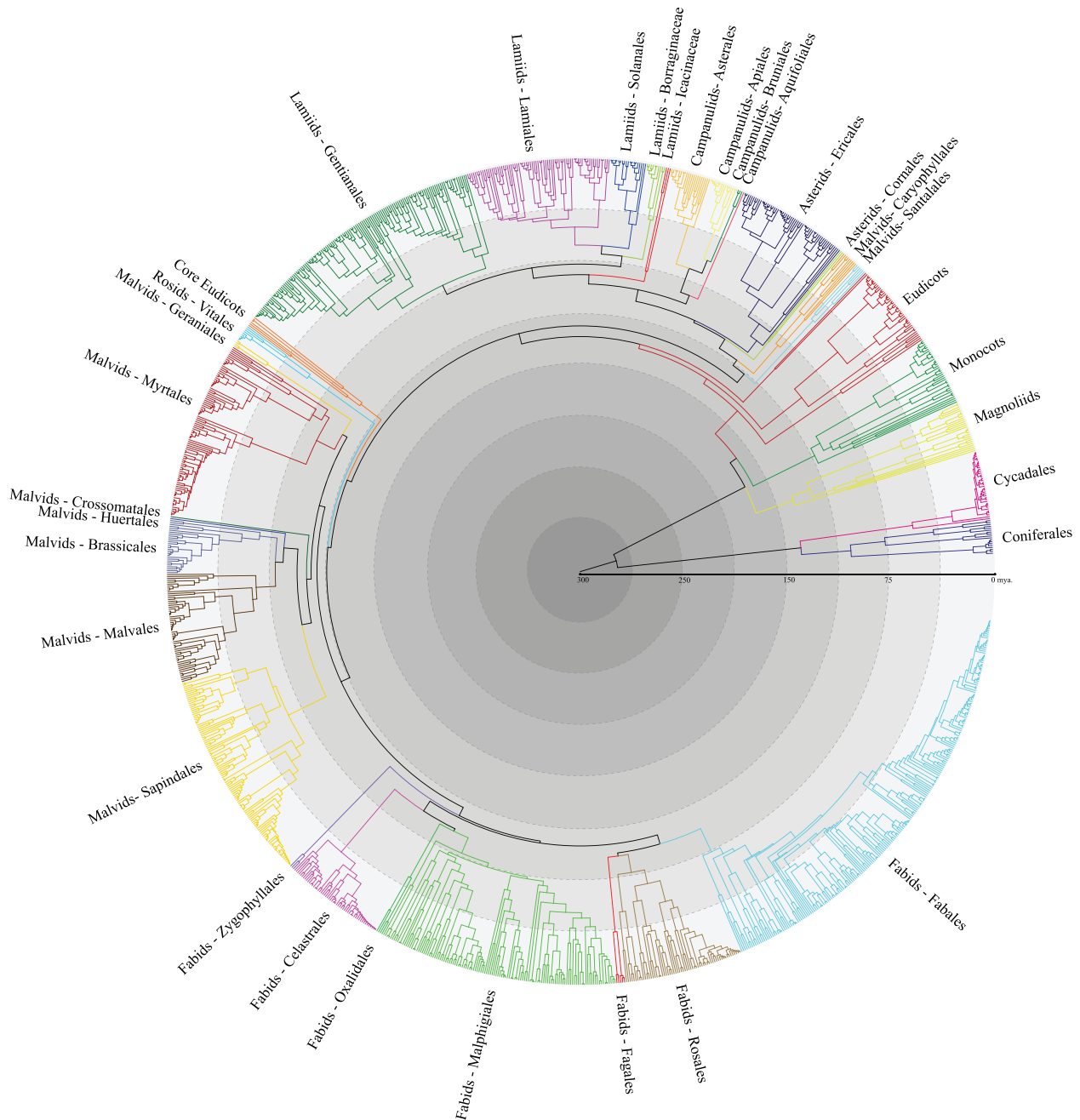

FIGURE 1 Phylogeny of southern African tree species. Reconstruction based on DNA barcodes for land plants using maximum likelihood and transforming branch lengths to millions of years by enforcing a relaxed molecular clock and multiple fossil calibrations. Colors indicate higher-level taxonomic groupings

outliers, classified as cells with z-scores > 3 , prior to estimating average densities, which matched closely to accepted criteria for urban areas in South Africa (≥ 500 people/km²) (Statistics South Africa, 2001). To capture information on socioeconomic factors, we also extracted data on mean per capita GDP between 1995–2015 (Kummu et al., 2018), proportion of land area converted to cropland (data set <http://sedac.ciesin.columbia.edu/es/aglands.html>), and fertilizer (Nitrogen) use (data set <http://sedac.ciesin.columbia.edu/data/collection/fertilizer-and-manure.html>).

[ciesin.columbia.edu/data/collection/fertilizer-and-manure.html](http://sedac.ciesin.columbia.edu/data/collection/fertilizer-and-manure.html)).

Data processing was performed in ArcMap v.10.0 and R (v. 4.0.3) using the libraries *ape*, *picante*, *sf*, *raster*, *rgdal*, *mapproj*, *maps*, *sp*, and *ggplot2*.

We used structural equation modeling (SEM) in the *sem* r-library to describe the direct and indirect effects of environment and woody plant diversity on human population. All variables except variance in elevation, latitude, and

longitude were log-transformed prior to analysis. Elevation was cube-root transformed, and latitude and longitude were indexed using decimal degrees. We included longitude and latitude to account for additional spatial structure in the data. To reduce model complexity, we first included only pathways with pairwise correlation strengths > 0.5 (Figure S6), and compared the fit of this model to one including additional pathways, and a model including links with socioeconomic factors.

To separate out the importance of number of species versus species evolutionary disparity, we substituted PD for a richness independent component of evolutionary disparity, phylogenetic species variability (PSV), and a separate measure of richness discounted for species relatedness, phylogenetic species richness (PSR) (Helmus et al., 2007). The metric of PSV is equivalent to the mean pairwise distance between taxa in an assemblage; taxon sets with high PSV are composed of species that are less closely related, on average, than taxon sets with low PSV, which are composed of more closely related species. PSR is simply the number of species in a set multiplied by their evolutionary relatedness (PSV). To evaluate model sensitivity, we constructed matching SEMs but included species richness and the residual variation in PD from the regression of PD against richness in place of PSR and PSV, respectively.

We used a resampling approach to test whether more phylogenetically diverse woody plant communities capture a greater diversity of uses. For each cell, we randomly resampled species without replacement, and recorded the median number of species required to represent at least once all uses listed for the entire species set in the cell (1000 randomizations). We then regressed the median richness required for capturing diversity of recorded uses against per-cell PSV plus PSR, and in a second model per-cell species richness plus the residuals of PD regressed against species richness.

3 | RESULTS

Our reconstructed phylogeny of woody trees and shrubs (made available as a supplemental file) included over 1300 species from 115 families and 541 genera. Hotspots of woody shrub and tree species diversity are distributed along the coastal regions of eastern South Africa through to south Mozambique and Zimbabwe (Figure 2a and b).

Human population density (Figure 2c) correlates with both the number (Pearson's $r = 0.75$, $p = 0.027$ on 6.36 adjusted degrees of freedom to correct for spatial nonindependence) and phylogenetic diversity (Pearson's $r = 0.76$, $p = 0.022$ on 6.50 adjusted degrees of freedom) of woody plants. We report results here using half-degree cells because this represented the native coordinate sys-

tem of the climate and human population density layers; however, correlations using equal-area grid cells were qualitatively similar.

We found evidence for a direct relationship between AET and both human population density and woody plant phylogenetic diversity (Figure 3a). However, the relationship between AET and human population density was mediated by an indirect relationship via phylogenetic diversity, and the strength of the direct pathway linking phylogenetic diversity and human density ($\beta = 0.43$) was greater than that for the direct pathway between AET and human density ($\beta = 0.34$) (Figure 3a). Topographic heterogeneity and latitude were not significant predictors in the SEM favored by model comparison statistics ($\Delta\text{BIC} = 281.39$, for the comparison between models depicted in Figures 3a and S1),

The pathway linking woody plant diversity and rural human population density was robust to the inclusion of additional socioeconomic predictors, including per capita GDP, area of habitat converted to cropland and fertilizer use ($\Delta\text{BIC} = 362.46$, for the comparison between models depicted in Figures 3a and S2). The simpler model supporting the stronger link between woody plant phylogenetic diversity and human population density was also vastly favored over alternative models including more complex path structure ($\Delta\text{BIC} = 1052.33$ for the comparison between models depicted in Figures 3a and S3).

The pathways linking human density to PSR (richness discounted for species relatedness) and PSV (richness independent component of evolutionary disparity) were both strongly supported (Figure 3b). The independent contribution of phylogenetic diversity is further demonstrated when we include in our SEM both species richness and the residual variation in phylogenetic diversity from the regression of phylogenetic diversity against richness (Figure S4). However, we note that the SEM including phylogenetic diversity is favored overall ($\Delta\text{BIC} = 145.97$, for the contrast between SEMs with phylogenetic diversity and PSR plus PSV), as it captures both richness and evolutionary disparity in a single unifying metric.

Plant uses show some evidence for phylogenetic conservatism (Figure 4), such that closely related species tend to provide similar uses, with the exception of spiritual uses. However, uses are not restricted to particular clades, and each of our 11 use categories is well represented across plant orders. Our resampling approach quantified the median number of species required to represent at least once each of the different uses identified for the species within a given grid cell when drawing species at random from the species set. Overall, more species had to be sampled to represent the same number of uses in more species-rich cells; however, after correcting for

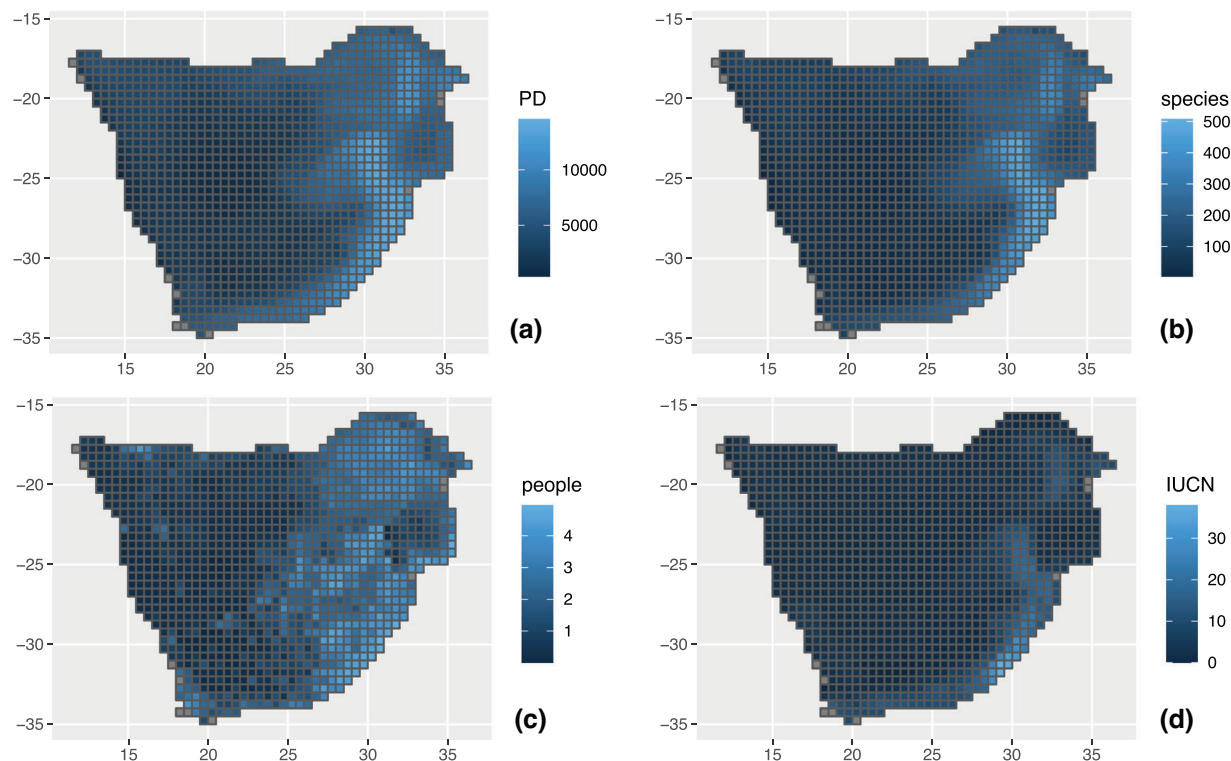

FIGURE 2 Geographical distribution of tree diversity and human population density. Tree phylogenetic diversity (myr) (a), total tree species richness (b), natural logarithm of the mean human population density (persons/km²) excluding urban areas (c), and richness of threatened trees (d). Data were divided into 32 quantiles and plotted on a 0.5° × 0.5° grid

TABLE 1 Regression of median number of species required to capture the uses represented within each grid cell

Model	r^2_{adjusted}	DF	p Value	Coefficient	Estimate (SE)	t value
1	0.77	1204	<0.001	Log(PSR)*	4.97 (0.97)	59.43
				PSV*	−29.71 (2.73)	−10.90
2	0.78	1204	<0.001	Log(Richness)*	4.75 (0.07)	65.16
				PD _{residuals} *	−0.002 (< 0.001)	−11.59

*Significant at $p < 0.001$.

variation in species richness, new uses were encountered at an increased rate in more phylogenetically dispersed species sets (Table 1).

4 | DISCUSSION

Human population density in sub-Saharan Africa correlates with not only the richness of woody plants, but also their evolutionary relatedness. An important body of work has indicated that more phylogenetically diverse species sets capture a greater diversity of ecosystem services and goods of benefit to people (Forest et al., 2007; Molina-Venegas et al., 2021). Here, we demonstrate that the relationship between phylogenetic diversity and ecosystem services maps to the distribution of species across

the landscape. Our study emphasizes the importance of maintaining both species rich and phylogenetically diverse habitats to support Nature's contributions to people (Chaplin-Kramer et al., 2019).

We excluded urban areas from our analysis because other factors, such as economic development, industrialization, and global trade have likely influenced the geography of urban populations. However, cities in Africa predate European colonialization (Mboup, 2019), and the correlations with phylogenetic diversity are largely unchanged (are in fact marginally stronger) when centers of high population density were included (Figure S5). The link between woody plant phylogenetic diversity and human population was also robust to the inclusion of additional socioeconomic predictors including per capita GDP and proportion of habitat converted to cropland.

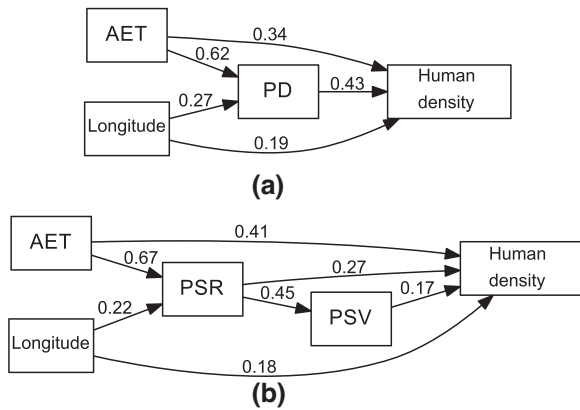

FIGURE 3 Structural equation models. Illustration of the direct and indirect effects of actual evapotranspiration (AET), phylogenetic diversity (PD) and longitude on human population density (a - top panel), and an equivalent model decomposing phylogenetic diversity into a richness independent measure of evolutionary disparity (PSV) and a measure of richness discounted for species relatedness (PSR) (b - bottom panel). Model a is favored by model fit statistics (BIC = 1129.78 and 1275.75 for model a and b respectively), although model b explains more of the total variation in human population density ($r^2 = 0.56$ versus 0.59 for human density, model a and b, respectively). Arrows indicate inferred direction of causation and numbers relative path strengths (standardized coefficients). The inclusion of additional pathways, such as the direct and indirect effects of elevation and latitude (Fig. S4), was not supported by model comparison statistics

In biodiversity ecosystem function research, greater species richness is thought to enhance ecosystem functioning through species complementarity and the selection effect (Loreau & Hector, 2001). The former assumes that different species occupy separate ecological niches or that there are facilitative interactions among species. The latter assumes that one or a few species contribute disproportionately to ecosystem functioning and, that by including a larger sample of species, more species-rich communities are more likely to include a species with large effect. Both effects are contingent on species differences, and phylogenetic diversity might better capture these differences than simple measures of species richness (Purvis & Hector, 2000). We suggest similar mechanisms may underlie the relationship between woody plant diversity and the diversity of uses they provide.

Some woody plants support a wide range of uses, filling both material and spiritual needs, while many others provide just a single service, most often medicinal. The selection effect might therefore be one part of the explanation for the diversity-ecosystem multifunctionality relationship we detect: species rich woody plant communities are more likely to include species offering multiple service. However, there is also evidence that at least some

services show phylogenetic signal, such that more closely related species are more likely to provide similar services (Yessoufou et al., 2015). Thus, the complementarity effect may be another important part of the explanation. The diversity of ecosystem services is a product of not only species number, but also how different species are from one another, that is, their phylogenetic dispersion. The complementarity effect may be particularly prevalent when there is a trade-off between provisioning of different services (Slade et al., 2019), when rare species provide unique services, and/or the provisioning of a service is independent from abundance (Dee et al., 2019).

Whether local scale species diversity necessarily translates into greater local provisioning of ecosystem services is not straightforward. For example, interspecific competition between species might reduce the abundance and therefore the ecosystem service provisioning of competing species (Slade et al., 2019). In this case, increased multifunctionality might come at a cost of reduced provisioning of individual services (Fanin et al., 2018). In South Africa, there is some evidence to suggest that spatial concordance in the provisioning of different ecosystem services, such as those related to fire regulation (e.g., surface water flow, soil accumulation and carbon storage) may be low (Egoh et al., 2008). However, tradeoffs can be avoided, especially in provisioning services, when aggregating across heterogeneous landscapes that support different species communities (Mori et al., 2018), analogous to the spatial insurance hypothesis (Loreau et al., 2003; Isbell et al., 2017).

Our analysis of human population density, AET, and woody plant phylogenetic diversity is correlational. While it is tempting to speculate on the causal linkages between them, the history of people in sub-Saharan Africa is complex, capturing a legacy of colonization and independence. Nonetheless, it remains possible that the correlations we reveal reflect, in some part, a pattern of rural settlement in Africa. AET is the sum of evaporation and transpiration, and the correlation between AET and woody plant diversity is unsurprising; AET is a good proxy for plant productivity and a strong predictor of global plant species richness. A correlation between AET and human density might arise because people tend to settle in regions that have potential to support high agricultural productivity. Similarly, a largely agrarian population may have been drawn to ecosystem with more phylogenetically diverse woody floras to benefit from the multiple services they provided. However, it is also likely that, over the history of settlement in Africa, humans have shaped the local environment to their needs. People have long influenced the floristic diversity of their local environments (Armstrong et al., 2021), and the path for either direction of causality is equally well supported.

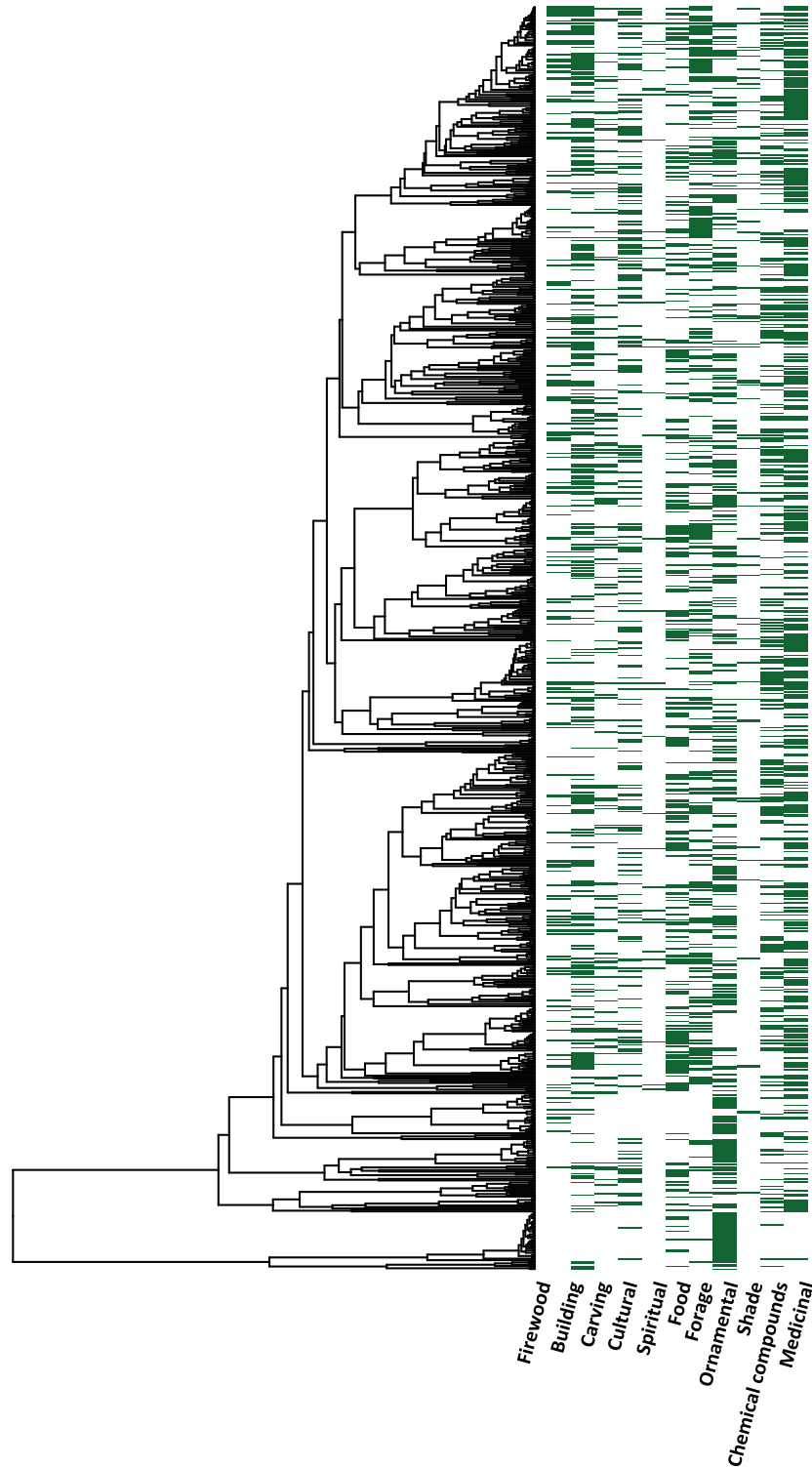

FIGURE 4 Phylogenetic distribution of plant uses. Classes of plant uses (green bars) matched to the respective plant taxon. Overall, most uses show significant phylogenetic structure (estimated using the D statistic for binary traits as implemented in the r-library caper, where $D = 0$ matches to a Brownian threshold model of evolution, and $D = 1$ indicates no phylogenetic structure; matches to random expect an unconstrained depart significantly from random; $D = 1$). However, phylogenetic conservatism departs from strict Brownian motion ($D > 0$, range 0.69–0.85, all $p < 0.01$), and the phylogenetic structure of spiritual uses does not differ significantly differ from random ($D = 0.95$, probability observations differ from random expectations: $p = 0.18$). These results are perhaps not surprising, as most uses relate to some structural or physiological properties of the plant, which we might expect to exhibit phylogenetic conservatism, whereas the selection of plants for spiritual uses is more esoteric

4.1 | A tension between people and nature conservation

Irrespective of the underlying drivers, the correlation between human population density and woody plant diversity presents a tension between people and nature conservation (Balmford et al., 2001; Luck et al., 2004), especially as demand for energy and land for agriculture intensifies. Using information on extinction risk status from the Red List for South African plants (<http://redlist.sanbi.org/>), we find that not only does the total number of woody plant species correlate positively with human population, but so too does the number of threatened species ($r = 0.54$, $p < 0.001$; Figure 2d). Of the species currently considered most at risk, many are nested within young and rapidly diversifying clades (Davies et al., 2011), and so their extinction, while tragic, translates to little loss of phylogenetic diversity. However, as extinction pressures intensify, we risk losing not just the leaves, but whole branches from the Tree of Life.

The report of the Intergovernmental Science-Policy Platform on Biodiversity and Ecosystem Services (IPBES, 2019) recognized the value of phylogenetic diversity in maintaining option values in an uncertain future. Here we have shown that phylogenetic diversity may also represent a useful proxy for the wealth of ecosystem goods and services that nature provides (see also Molina-Venegas et al., 2021). Phylogenetic diversity has only rarely been directly integrated into conservation planning, yet the gain in phylogenetic diversity with the expansion of protected areas is easily calculated, and it can be incorporated into mainstream conservation planning tools that examine trade-offs across multiple cost-benefit axes (see Carvalho et al., 2017; Rosauer et al., 2018). Empirical case studies demonstrate how systematic conservation planning can target small, but well-placed conservation areas, which provide large phylogenetic diversity gains (Pollock et al., 2015; Rosauer et al., 2018). Importantly, however, our analyses suggest that systematic reserve selection should not only look to maximize the total phylogenetic diversity across protected areas, which may be important for maintaining future options (Faith, 1992), but also the local phylogenetic diversity within sites. Further, we suggest the most immediate gains from conserving phylogenetic diversity may be realized in mixed use landscapes, where people can directly benefit from nature's contributions. We propose that it is in these landscapes that policy efforts directed toward the conservation of phylogenetic diversity may benefit the most.

ACKNOWLEDGMENTS

This research was supported by the Government of Canada through Genome Canada and the Ontario Genomics

Institute (2008-OGI-ICI-03), the University of Johannesburg, the South African National Research Foundation, the Royal Society (UK), and the Toyota South Africa through the Toyota Enviro Outreach Programme. KY was additionally supported by NRF grant #112113.

DATA AVAILABILITY STATEMENT

The reconstructed phylogeny of woody trees and shrubs, and the geospatial data matrix needed to replicate the structural equation models and correlations are available from the Knowledge Network for Biocomplexity at <https://doi.org/10.5063/F1VX0DZ1>.

REFERENCES

- Armstrong, C., Miller, J., McAlvay, A. C., Ritchie, P. M., & Lepofsky, D. (2021). Historical indigenous land-use explains plant functional trait diversity. *Ecology and Society*, 2, 6.
- Balmford, A., Moore, J. L., Brooks, T., Burgess, N., Hansen, L. A., Williams, P., & Rahbek, C. (2001). Conservation conflicts across Africa. *Science*, 291, 2616–2619.
- de Bello, F., Lavorel, S., Díaz, S., Harrington, R., Cornelissen, J. H. C., Bardgett, R. D., Berg, M. P., Cipriotti, P., Feld, C. K., Hering, D., Martins da Silva, P., Potts, S. G., Sandin, L., Sousa, J. P., Storkey, J., Wardle, D. A., & Harrison, P. A. (2010). Towards an assessment of multiple ecosystem processes and services via functional traits. *Biodiversity and Conservation*, 19, 2873–2893.
- Carvalho, S. B., Velo-Anton, G., Tarroso, P., Portela, A. P., Barata, M., Carranza, S., Moritz, C., & Possingham, H. P. (2017). Spatial conservation prioritization of biodiversity spanning the evolutionary continuum. *Nature Ecology & Evolution*, 1, 1–8.
- Chaplin-Kramer, R., Sharp, R. P., Weil, C., Bennett, E. M., Pascual, U., Arkema, K. K., Brauman, K. A., Bryant, B. P., Guerry, A. D., Haddad, N. M., & Hamann, M. (2019). Global modeling of nature's contributions to people. *Science*, 366, 255–258.
- Coates Palgrave, K., Drummond, R. B., Moll, E. J., & Palgrave, M. C. (2002). *Trees of southern Africa*. Cape Town.
- Davies, T. J., Smith, G. F., Bellstedt, D. U., Boatwright, J. S., Bytebier, B., Cowling, R. M., Forest, F., Harmon, L. J., Muasya, A. M., Schrire, B. D., & Steenkamp, Y. (2011). Extinction risk and diversification are linked in a plant biodiversity hotspot. *PLoS Biology*, 9, e1000620.
- Dee, L. E., Cowles, J., Isbell, F., Pau, S., Gaines, S. D., & Reich, P. B. (2019). When do ecosystem services depend on rare species? *Trends in Ecology & Evolution*, 34, 746–758.
- Díaz, S., Lavorel, S., de Bello, F., Quétier, F., Grigulis, K., & Robson, T. M. (2007). Incorporating plant functional diversity effects in ecosystem service assessments. *Proceedings of the National Academy of Sciences of the United States of America*, 104, 20684–20689.
- Duffy, J. E., Godwin, C. M., & Cardinale, B. J. (2017). Biodiversity effects in the wild are common and as strong as key drivers of productivity. *Nature*, 549, 261–264.
- Egoh, B., Reyers, B., Rouget, M., Bode, M., & Richardson, D. M. (2009). Spatial congruence between biodiversity and ecosystem services in South Africa. *Biological Conservation*, 142, 553–562.
- Egoh, B., Reyers, B., Rouget, M., Richardson, D. M., Le Maitre, D. C., & van Jaarsveld, A. S. (2008). Mapping ecosystem services for

- planning and management. *Agriculture Ecosystems and Environment*, 127, 135–140.
- Egoh, B. N., O'Farrell, P. J., Charef, A., Gurney, L. J., Koellner, T., Abi, H. N., Egoh, M., & Willemsen, L. (2012). An African account of ecosystem service provision: Use, threats and policy options for sustainable livelihoods. *Ecosystem Services*, 2, 71–81.
- Faith, D. P. (1992). Conservation evaluation and phylogenetic diversity. *Biological Conservation*, 61, 1–10.
- Fanin, N., Gundale, M. J., Farrell, M., Ciobanu, M., Baldock, J. A., Nilsson, M. C., Kardol, P., & Wardle, D. A. (2018). Consistent effects of biodiversity loss on multifunctionality across contrasting ecosystems. *Nature Ecology & Evolution*, 2, 269–278.
- Forest, F., Grenyer, R., Rouget, M., Davies, T. J., Cowling, R. M., Faith, D. P., Balmford, A., Manning, J. C., Procheş, S., van der Bank, M., Reeves, G., Hedderson, T. J., & Savolainen, V. (2007). Preserving the evolutionary potential of floras in biodiversity hotspots. *Nature*, 445, 757–760.
- Gamfeldt, L., Snäll, T., Bagchi, R., Jonsson, M., Gustafsson, L., Kjellander, P., Ruiz-Jaen, M. C., Fröberg, M., Stendahl, J., Philipson, C. D., Mikusiński, G., Andersson, E., Westerlund, B., Andrén, H., Moberg, F., Moen, J., & Bengtsson, J. (2013). Higher levels of multiple ecosystem services are found in forests with more tree species. *Nature Communication*, 4, 1–8.
- Hector, A., & Bagchi, R. (2007). Biodiversity and ecosystem multifunctionality. *Nature*, 448, 188–191.
- Helmus, M. R., Bland, T. J., Williams, C. K., & Ives, A. R. (2007). Phylogenetic measures of biodiversity. *American Naturalist*, 169, E68–E83.
- Hooper, D. U., Adair, E. C., Cardinale, B. J., Byrnes, J. E. K., Hungate, B. A., Matulich, K. L., Gonzalez, A., Duffy, J. E., Gamfeldt, L., & O'Connor, M. I. (2012). A global synthesis reveals biodiversity loss as a major driver of ecosystem change. *Nature*, 486, 105–108.
- Hooper, D. U., Chapin, F. S., Ewel, J. J., Hector, A., Inchausti, P., Lavorel, S., Lawton, J. H., Lodge, D. M., Loreau, M., Naem, S., Schmid, B., Setälä, H., Symstad, A. J., Vandermeer, J., & Wardle, D. A. (2005). Effects of biodiversity on ecosystem functioning: A consensus of current knowledge. *Ecological Monographs*, 75, 3–35.
- IPBES. (2019). *Global assessment report on biodiversity and ecosystem services of the Intergovernmental Science-Policy Platform on Biodiversity and Ecosystem Services*. E. S. Brondizio, J. Settele, S. Díaz, & H. T. Ngo (Eds.). Bonn, Germany: IPBES secretariat.
- Isbell, F., Calcagno, V., Hector, A., Connolly, J., Harpole, W. S., Reich, P. B., Scherer-Lorenzen, M., Schmid, B., Tilman, D., Van Ruijven, J., Weigelt, A., Wilsey, B. J., Zavaleta, E. S., & Loreau, M. (2011). High plant diversity is needed to maintain ecosystem services. *Nature*, 477, 199–202.
- Isbell, F., Gonzalez, A., Loreau, M., Cowles, J., Díaz, S., Hector, A., Mace, G. M., Wardle, D. A., O'Connor, M. I., Duffy, J. E., & Turnbull, L. A. (2017). Linking the influence and dependence of people on biodiversity across scales. *Nature*, 546, 65–72.
- Kummu, M., Taka, M., & Guillaume, J. H. A. (2018). Gridded global datasets for gross domestic product and Human Development Index over 1990–2015. *Scientific Data*, 5, 1–15.
- Liang, J., Crowther, T. W., Picard, N., Wiser, S., Zhou, M., Alberti, G., Schulze, E. D., McGuire, A. D., Bozzato, F., Pretzsch, H., de-Miguel, S., Paquette, A., Hérault, B., Scherer-Lorenzen, M., Barrett, C. B., Glick, H. B., Hengeveld, G. M., Nabuurs, G. J., Pfautsch, S., ... Reich, P. B. (2016). Positive biodiversity-productivity relationship predominant in global forests. *Science*, 354.
- Loreau, M., & Hector, A. (2001). Partitioning selection and complementarity in biodiversity experiments. *Nature*, 412, 72–76.
- Loreau, M., Mouquet, N., & Gonzalez, A. (2003). Biodiversity as spatial insurance in heterogeneous landscapes. *Proceedings of the National Academy of Sciences of the United States of America*, 100, 12765–12770.
- Luck, G. W., Ricketts, T. H., Daily, G. C., & Imhoff, M. (2004). Alleviating spatial conflict between people and biodiversity. *Proceedings of the National Academy of Sciences of the United States of America*, 101, 182–186.
- Malherbe, H., Pauleit, S., & Lorz, C. (2019). Mapping the loss of ecosystem services in a region under intensive land use along the southern coast of South Africa. *Land*, 8, 51.
- Mboup, G. (2019). African cities in time and space: Past, emerging trends and perspectives. In G. Mboup, & B. Oyelaran-Oyeyinka (Eds.). *Smart economy in smart African cities* (pp. 51–93). Singapore: Springer.
- Molina-Venegas, R., Rodríguez, M. Á., Pardo-de-Santayana, M., Ronquillo, C., & Maberley, D. J. (2021). Maximum levels of global phylogenetic diversity efficiently capture plant services for humankind. *Nature Ecology & Evolution*, 5(5), 583–588.
- Mori, A. S., Isbell, F., & Seidl, R. (2018). β -diversity, community assembly, and ecosystem functioning. *Trends in Ecology & Evolution*, 33, 549–564.
- O'Farrell, P. J., Reyers, B., Le Maitre, D. C., Milton, S. J., Egoh, B., Maherry, A., Colvin, C., Atkinson, D., De Lange, W., Blignaut, J. N., & Cowling, R. M. (2010). Multi-functional landscapes in semi arid environments: Implications for biodiversity and ecosystem services. *Landscape Ecology*, 25, 1231–1246.
- Perkins, D. M., Bailey, R. A., Dossena, M., Gamfeldt, L., Reiss, J., Trimmer, M., & Woodward, G. (2015). Higher biodiversity is required to sustain multiple ecosystem processes across temperature regimes. *Global Change Biology*, 21, 396–406.
- van der Plas, F., Ratcliffe, S., Ruiz-Benito, P., Scherer-Lorenzen, M., Verheyen, K., Wirth, C., Zavala, M. A., Ampoorter, E., Baeten, L., Barbaro, L., Bastias, C. C., Bauhus, J., Benavides, R., Benneter, A., Bonal, D., Bouriaud, O., Bruelheide, H., Bussotti, F., Carnol, M., ... Allan, E. (2018). Continental mapping of forest ecosystem functions reveals a high but unrealised potential for forest multifunctionality. *Ecology Letters*, 21, 31–42.
- Pollock, L. J., Rosauer, D. F., Thornhill, A. H., Kujala, H., Crisp, M. D., Miller, J. T., & McCarthy, M. A. (2015). Phylogenetic diversity meets conservation policy: Small areas are key to preserving euca-lypt lineages. *Philosophical Transactions of the Royal Society B*, 370, 20140007.
- van der Plas, F., Schröder-Georgi, T., Weigelt, A., Barry, K., Meyer, S., Alzate, A., Barnard, R. L., Buchmann, N., de Kroon, H., Ebeling, A., Eisenhauer, N., Engels, C., Fischer, M., Gleixner, G., Hildebrandt, A., Koller-France, E., Leimer, S., Milcu, A., Mommer, L., ... Wirth, C. (2020). Plant traits alone are poor predictors of ecosystem properties and long-term ecosystem functioning. *Nature Ecology & Evolution*, 4, 1602–1611.
- Purvis, A., & Hector, A. (2000). Getting the measure of biodiversity. *Nature*, 405, 212–219.
- Rosauer, D. F., Byrne, M., Blom, M. P., Coates, D. J., Donnellan, S., Doughty, P., Keogh, J. S., Kinloch, J., Laver, R. J., & Myers, C., & others. (2018). Real-world conservation planning for

- evolutionary diversity in the Kimberley, Australia, sidesteps uncertain taxonomy. *Conservation Letters*, *11*, e12438.
- Slade, E. M., Bagchi, R., Keller, N., & Philipson, C. D. (2019). When do more species maximize more ecosystem services? *Trends in Plant Science*, *24*, 790–793.
- Statistics South Africa. (2001). *Investigation into appropriate definitions of urban and rural areas for South Africa: Discussion document. Report No. 03-02-20*. Pretoria.
- UNICEF. (2012). *An urban world*.
- United Nation Economic Commission for Africa. (2010). *Climate Change and the Rural Economy in Southern Africa: Issues, Challenges and Opportunities. Report ref. ECA-SA/TPUB/CLIMATE2012/2*. 88p.
- United Nations. (2011). *Population distribution, urbanization, internal migration and development: An international perspective*. New York.
- Van Wyk, A. E., den Berg, E., Coates Palgrave, M., & Jordaan, M. (2011). *Dictionary of names for southern African trees. Scientific names of indigenous trees, shrubs and climbers with common names from 30 languages*. Pretoria, Briza Publications.

- Yessoufou, K., Daru, B. H., & Muasya, A. M. (2015). Phylogenetic exploration of commonly used medicinal plants in South Africa. *Molecular Ecology Resources*, *15*, 405–413.

SUPPORTING INFORMATION

Additional supporting information can be found online in the Supporting Information section at the end of this article.

How to cite this article: Davies, T. J., Maurin, O., Yessoufou, K., Daru, B. H., Bezeng, B. S., Mankga, L. T., Schaefer, H., Thuiller, W., & van der Bank, M. (2022). Woody plant phylogenetic diversity supports nature's contributions to people but is at risk from human population growth. *Conservation Letters*, e12914. <https://doi.org/10.1111/conl.12914>