

Dilution refrigerators for particle physics experiments: two variants with sample cooling by helium-4

B. van den Brandt ¹, P. Hautle ¹, J.A. Konter ¹, F.M. Piegsa ^{1,2},
J.P. Urrego-Blanco ^{1,3}

¹ Paul Scherrer Institute, CH-5232 Villigen PSI, Switzerland

² Physics Department, TU München, D-85748 Garching, Germany

³ Department of Physics and Astronomy, University of Tennessee, Knoxville, TN 37996, USA

E-mail: ton.konter@psi.ch

Abstract. Two variants are described of ³He-⁴He dilution refrigerators for experiments with polarized nuclei in particle beams, which often have to be performed under adverse experimental conditions. The first is used for experiments in a beam of cold neutrons that do not allow any ³He on their beam path. The sample is therefore indirectly cooled by liquid ⁴He.

The second variant is used for experiments in a beam of heavy nuclei that only allow a very thin film of material, in this case ⁴He, to cool a thin polarized polystyrene target. Such a polarized target is a powerful spectroscopic tool to investigate nuclear structure and reaction mechanisms, which is of interest for the study of nuclei far from stability.

1. Introduction

A convenient way to reach milliKelvin temperatures is dilution refrigeration. The first refrigerator with a lowest temperature of 220 mK was built in 1965 by Das, de Bruyn Ouboter and Taconis [1]. A steady improvement followed, leading to a lowest temperature of 8 mK in the ⁴He-circulating version in 1976 by Pennings, de Bruyn Ouboter and Taconis [2] and 2 mK in 1978 in the ³He-circulating version by Frossati [3]. Most of the instruments developed for applications in solid state physics or materials research are not suited for experiments in particle physics with polarized targets, because of many experimental conditions and constraints, related to target loading, beam access, detector opening angles etc.

Here we present two special dilution refrigerators for particle scattering experiments: one for experiments in a cold neutron beam, where the slightest amount of ³He is prohibitive, because of the very large neutron absorption cross section, and one for experiments in a beam of heavy particles, where the total amount of any material including He, should be kept as low as possible and cooling of the sample has to be realized by a ⁴He film.

The two systems have in common that the nuclei of interest in the sample (protons, deuterons etc.) are polarized by Dynamic Nuclear Polarization (DNP) [4], a process in which the polarization of free electrons, almost fully polarized at temperatures below 1 K and magnetic fields of ~ 2.5 T, is transferred to the nearby nuclei by irradiation with microwaves at a frequency close to the ESR line. This requires in general a cooling power of 0.5 - 1 mW per cm³ sample material at temperatures below 0.5 K, plus the heat dissipated by the incoming particle beam.

Both systems are based on a design of a special dilution refrigerator for polarized nuclei by Roubeau [5].

The characteristics of this design are firstly that the whole refrigerator is fully contained in its own pumping tube and can be taken out or re-inserted in a short time even in a cold cryostat (thus allowing loading of samples kept at 77 K). Secondly, the mixing chamber is directly in the isolation vacuum of the cryostat, thus minimizing the amount of material in the beam path. A further development at PSI incorporated a removable central access [6], enabling a faster target change, or an angle-reproducible loading of special-shaped targets, or even the use of multi-stage or dummy-targets, up to sizes of 100 cm³ [7].

2. Dilution refrigerator for samples in a cold neutron beam

2.1. Constraints in a beam of cold neutrons

As mentioned above, no ³He at all can be tolerated in the cold neutron beam. Therefore, an apparatus had to be developed with a dilution refrigerator and a separate ⁴He chamber for the cooling of the sample. The refrigerator is used in an experiment to determine the spin-dependent scattering length of the deuteron. The experiment with a Ramsey apparatus was described elsewhere [8]. A severe geometrical limitation is that the tail of the cryostat has to fit between the pole shoes of an electromagnet, 49 mm apart. Since the cryostat is operated without ℓ N₂ because of compactness, two gas cooled shields and a shield on still-temperature were used, reducing the available space even more.

2.2. Experimental set-up for a beam of cold neutrons

The lower part of the cryostat is shown in figure 1. A dilution refrigerator with a central microwave guide was used. The mixing chamber, filled with mixture, and the sample cell, filled

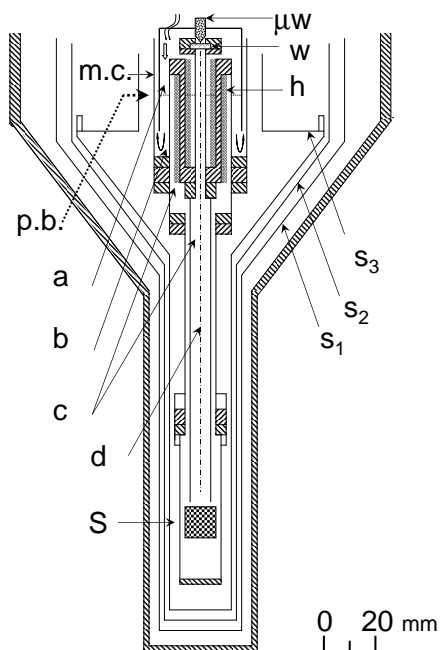

Figure 1. The lower part of the cryostat with the mixing chamber (m.c.) filled with ³He-⁴He mixture, the ³He rich phase (a), the diluted phase (b), the phase boundary between them (p.b.), the microwave guide (μw), the sapphire microwave window (w) and heat exchanger (h) between mixing chamber and sample cell are shown. The sample (S) is embedded in liquid ⁴He (c) and mounted on microwave guide (d). The sample cell is surrounded by aluminium radiation shields at 120 K (s₁), 30 K (s₂) and 1 K (s₃).

with pure ^4He , are connected by a vertical, coaxial heat exchanger, made out of a cylindrical friction weld from stainless steel (the flange part) to copper (the thermal part) with silver powder sintered on both sides in annular, spark eroded, grooves. A sapphire window allows microwaves to pass. The sintered silver heat exchanger has on the mixing chamber side 20.6 g silver powder [9], on the sample side 27.7 g.

The sample cell is also made out of a friction weld, this time between stainless steel for the indium-sealed flange and aluminum for the lower cylindrical part in the neutron beam region with a thickness of 0.5 mm. The indium-sealed flange adds only 2 mm radially to the 19 mm outside diameter of the sample cell.

The sample, a 1.2 mm polystyrene platelet of Ø 5 mm, was situated ~ 16 cm below the mixing chamber. Without microwave irradiation the lowest temperature of the sample was 92 mK with < 70 mK in the mixing chamber. Typical polarization values achieved were 40% for protons and 20% for deuterons. During polarization, the ^3He flow rate was increased to ~ 1 mmol/s. The thermal gradient from sample to mixing chamber is mainly determined by the low thermal conductivity of ^4He at these temperatures.

3. Dilution refrigerator for samples in a beam of heavy nuclei

3.1. Constraints in a beam of heavy nuclei

Further we developed a dilution refrigerator with a solid target of polarized protons for experiments with radioactive ion beams. (Tests at PSI were performed with beams of ^{12}C of 60 MeV or ^{14}N of 170 MeV at a rate of $< 5 \times 10^6/\text{s}$.) Such experiments are of interest in areas as diverse as resonant elastic scattering, transfer reactions and nuclear matter distributions in nuclei far from stability [10]. Such targets hold great promise in the context of exotic nuclei. Using the DNP technique, in the past, $70 \mu\text{m}$ thick scintillating polystyrene foils had been polarized at PSI to 84% inside the mixing chamber of a ^3He - ^4He dilution refrigerator [11]. We report now on the development of a polarized target based on plastic foils of 1-200 μm thickness, placed inside a separate chamber attached to the mixing chamber. Cooling of the foil is achieved via a superfluid film of ^4He , keeping the beam's energy loss and recoils at a low level. [12]. The chamber has two 500 nm thin, highly uniform silicon nitride windows. A NMR coil is attached to the target foil to monitor the polarization. First results have been obtained to characterize the target system, using the elastic scattering of 38 MeV ^{12}C by protons in inverse kinematics. This development confronted us with several technical challenges.

To reduce the amount of material in the beam path to the absolute minimum, the cryostat- and the beamline-vacuum ($\simeq 10^{-5}$) mbar were connected, but sufficiently decoupled by allowing only a 9 mm hole in the connecting flange. Thus the cryostat-vacuum could be kept at the 10^{-7} mbar level to avoid contamination condensation on the windows in the beam path.

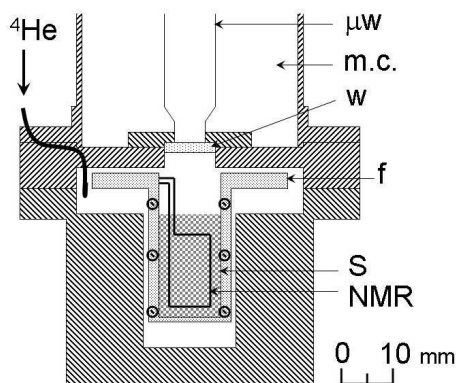

Figure 2. Schematic frontal view of the sample cell, situated below the mixing chamber (m.c.), with sample (S) mounted on a copper frame (f) with visible clamping screws and a rectangular NMR coil. Microwaves from waveguide (μw) enter the sample cell through a sapphire window (w).

For experiments that involve low-energy recoils another challenge is related to their trajectories in the high magnetic field. In this case, the target has to be operated in the so called frozen spin mode, in which protons are first polarized at 2.5 T until the maximum polarization is reached. Subsequently microwave irradiation is interrupted, the temperature is lowered to typically ~ 100 mK, and the magnetic field lowered to a value in the range between 0.4 T and 1 T. Under these conditions the nuclear polarization is expected to exhibit still sufficiently long relaxation times.

3.2. Experimental set-up for a beam of heavy nuclei

All heat shields have open window sections in the incoming beam line, except for the shield at 4.2 K, the outer shell of the superconducting split-pair magnet, which has a window covered with a 0.2 μm gold foil to reduce the thermal radiation to the inside. No material at all, except for the silicon-nitride exit window, was in the solid angle subtended from the target to the detectors, which were mounted in the gap of the superconducting magnet, at the position of the $B = 0$ circle. Since the silicon-nitride windows used do not withstand more than about 300 mbar differential pressure, a special pumping scheme had to be adopted for the evacuation of the cryostat and the sample cell.

Figure 2 shows the target cell, containing as sample a 60 μm polystyrene foil of 16 mm \times 20 mm (~ 40 mg/cm²), with an embedded 1 mm diameter copper NMR coil. Microwaves are entering via a sapphire window in the bottom of the mixing chamber. A coverage of the sample by a 0.3 μm superfluid ⁴He film for the thermal transport is obtained by admitting 0.26 cm³ NTP ⁴He gas. Without microwave irradiation the lowest temperature of a calibrated ruthenium oxide thermometer on the NMR coil read 190 mK, with < 100 mK in the mixing chamber. The highest proton polarization was 30 %.

4. Conclusions

Two variants were described of set-ups for particle physics experiments, where indirect cooling of the samples by a dilution refrigerator via bulk ⁴He or a ⁴He film was successfully realized.

5. Acknowledgements

We especially acknowledge the technical support by W. Arrigoni, M. Schmutz and P. Schurter, whose outstanding skills have made these experiments possible.

- [1] P. Das, R. de Bruyn Ouboter and K.W. Taconis *Proc. 9th Int. Conf. on Low Temp. Phys.* Plenum Press, London, (1965) p.1253
- [2] N.H. Pennings, R. de Bruyn Ouboter and K.W. Taconis *Physica* B84 (1976) 249
- [3] G. Frossati *J. Physique C* **39** (1978) 1578
- [4] A. Abragam and M. Goldman *Nuclear magnetism: order and disorder*, Oxford University Press (1982).
- [5] P. Roubeau *Proc. 6th Int. Cryogenic Engineering Conf.* (1976) p. 99
- [6] B. van den Brandt, J.A. Konter and S. Mango *Nucl. Instr. and Meth. A* **289** (1990) 526-531
- [7] B. van den Brandt, P. Hautle, J.A. Konter and S. Mango *Nucl. Instr. and Meth. A* **356** (1995) 53-55
- [8] F.M. Piegsa et al. *Nucl. Instr. Meth. A* **589** (2008) 318
- [9] XRP5 flakes, CLAL, 13, rue de Montmorency, 75139 Paris
- [10] J.P. Urrego-Blanco et al. *Nucl. Instr. Meth. B* **261** (2007) 1112-16
- [11] B. van den Brandt, E.I. Bunyatova, P. Hautle, J.A. Konter and S. Mango *Nucl. Instr. Meth. A* **446** (2000) 592-599
- [12] B. van den Brandt, P. Hautle, Yu.F. Kisselev, J.A. Konter and S. Mango *Nucl. Instr. Meth. A* **381** (1996) 219-222