

*

Review

#2 | 19

Department of
Architecture

Coverstory: Since 2016, on International Women's Day, Parity Talks are taking place at the Department of Architecture at the ETH Zurich. The first three issues of the Parity Talks were organized by members of the Parity Group, a bottom-up initiative of assistants and students.



The Goal: A public debate on gender equality and diversity in architectural education and professional practice in Switzerland and abroad.

For their Parity Talks the Department of Architecture at the ETHZ worked with local graphic designers Völlm+Walther to feminize the portraits of architects, like Jacques Herzog and Pierre de Meuron (p.8).

With the aim to initiate a vibrant discussion at the TUM Department of Architecture, we asked Prof. Dr. Frank Petzold (cover) and Prof. Hermann Kaufmann (p.25) for collaboration.

Illustrations: Lisa Bamberg

© TUM Department of Architecture

“In Germany, women earn less than men in all occupational categories.”

Sandra Schuster, p. 24 ff

“[...] either we shape this change now, or at some point it will be shaped by forces that we may not even want to be shaped by.”

Benedikt Boucsein, p. 12 ff

“Recent developments [...] suggest that democracy is currently under threat.”

Dietrich Erben, p. 84 ff

Preface

Dear Students, Alumni, Partners and Friends,

This issue of REVIEW gives a selective overview of the activities of the past few months.

TUM Architecture is part of one of the most dynamic technical universities in Europe. Embedded in an excellent living and research environment, we are proactively taking advantage of the outstanding Munich ecosystem to strengthen our educational programs and research networks.

We have appointed Prof. Kathrin Dörfler to the professorship for Digital Fabrication. Under her direction, an Augmented Fabrication Lab will be set up. The new research group is located at the interface of architecture, robotics, and human-computer interaction.

Furthermore, we welcome Prof. Alexander von Kienlin to the professorship for Building History, Building Research and Conservation. His research interests range from the timber constructions of the antique world to historicism and post-war architecture. Most recently, he was dean of studies at the TU Braunschweig. One main area of research at our department is about the conservation and rebuilding of architectural and cultural heritage. Kienlin will further improve our cross-disciplinary network in this field, called REUSED.

In 2019, TUM secured the title “University of Excellence” for the third time in succession. Within the framework of the Excellence Strategy of the Federal and the State Governments, our university has announced its Agenda 2030. Next to the humanities, design is to become the second driving force of TUM towards a more human-centered engineering. We are in charge of integrating more intensively design practice and design thinking into technology development processes at TUM. Therefore, we will promote a new Integrated Research Center (IRC) in the field of Design and Technology.

The institute crosslinks our Department of Architecture with other TUM disciplines, especially informatics, engineering and management. The IRC will not only seek to enable new working methods, incorporating design, for students and researchers, but also to positively influence their mindsets and, thus, support the ongoing transformation of TUM as an organization.

Additionally, a new governance structure will bring about extensive organizational changes. Our familiar “Fakultäten” will be replaced by schools that will widen TUM’s radius of action at the interfaces of classical disciplines. The Department of Architecture will intensify its collaboration with other engineering disciplines on a long-term basis.

Enjoy reading,

Andreas Hild, Dean

Table of Contents

SHORT STORIES – HIGHLIGHTS OF THE ACADEMIC YEAR

The Adventure of the Empty House	8
New recruiting Platform for Built-Environment Sector	8
Workshop on Equality, Diversity and Inclusion in conjunction with Parity Talks IV at ETHZ	8
Sustainable Residential Buildings on the Garching Campus	9
TUM Architecture successful in BAM Ranking 2019	9
Establishing the Scientific Consortium “Architectural and Global Health”	9
New Professor & Guest Professors	56
Laboratory: Hack the City	83
Lecture series: Inspirations from the Global South	87
Preview: Hanne Deubzer	97

YOUNG TALENT AWARDS	38
---------------------	----

CLOSE UPS – INSIGHTS TO EXHIBITIONS & DESIGN PROJECTS

Exhibition: CIRCOLUTION	10
Project: Municipal Stadium on Grünwalder Straße	20
Seminar / Symposium: Action, Intervention, Participation	32
Project: COMMUNITREE	46
Project: Studiolo	60
Publication: Building Register IV	66
Conference: Research Perspectives in Architecture	68
Exhibition: XII International Architecture Biennale of São Paulo	70
Conference: PowerSKIN 2019	78
Laboratory: The City demands our Attention	82

Table of Contents

LONG STORIES – RESEARCH REPORTS, ESSAYS, INTERVIEWS

Laboratory for the Everyday City – Interview with Benedikt Boucsein	12
Knowledge-intensive Firms, Connectivity and Spatial Restructuring Dynamics and Differences in Germany and Switzerland	18
Women in Architecture	24
Observe & Conserve OLYMPIC FOLLIES	34
Affordable Palace	40
Buzludzha Monument Project	44
The Architecture Machine	48
Interview with Eike Schling	52
BIMwood Research Project	62
Inside Out? Recalibrating Munich Metropolitan Region	71
Balkrishna Doshi	72
The Architecture of Democracy	84

SELECTION OF PUBLICATIONS & ARTICLES	88
--------------------------------------	----

STAFF INDEX	94
-------------	----

IMPRINT	97
---------	----



The Adventure of the Empty House
As an artist, photographer and director, Vilma Pflaum deals with history and narrative in her works. Making the hidden and concealed visible is characteristic of her work. The sensitive handling of the material and the individual production technique is an immanent part of her work. Documenting, scenic and conceptual approaches can be found at the same level in the artist's repertoire. Photo: Wolke, © Vilma Pflaum www.vilmapflaum.com

The Adventure of the Empty House

In Munich's early 1960s, two administrative buildings by architect Walter Henn were built in quick succession. The Osram Forschungszentrale in Untergiesing and the Deckel Maschinenwerke in Obersendling resemble each other like twins, but met with dissimilar destinies. After its demolition in 2018, only the iconic photographs by Heinrich Heidersberger remain of Osram, while the administrative building of Deckel was put to a new use in 2019. In cooperation with the photographer Vilma Pflaum, the composer Benedikt Brachtel, and the organization for contemporary photography "Der Greif", the Chair of Recent Building Heritage Conservation developed a multimedia installation on the ongoing construction site. On the evening of the event, the building was illuminated in reference to Heidersberger's well-known photograph. The view of the exterior façade and the resulting image were thus reminiscent of architectural photography of the 1960s. At the same time, an audiovisual installation took all seven floors, which were being remodeled, into a discourse between observer, art and substance. The constant negotiation between building, changing requirements, and individual reception was tangible. The often preoccupying appearance of 1960s buildings, and the issues of how to deal with building stock and its perception were debated during a panel discussion. Directly on the construction site, in a dialogue between old and new, all actors dealt with issues of process, mash-up and collage. The project ran in February 2019 at Plinganserstraße 150. It was supervised by Europa Frohwein from NB and supported by Kulturreferat LHM, BA19 LHM, Pronovi, Schnitzer&, FotoLeutner Wien, Limelight, Bayerische Architektenkammer.

New recruiting Platform for Built-Environment Sector

The digitization of the construction industry is proceeding at full speed. Building data is being recorded more and more exhaustively and as a result, the entire building process, from design to construction, should run more smoothly. At the same time, the competition for well-trained specialists is becoming ever stronger. This development is exploited by SKILLARY, a TUM spin-off: The new platform links up talented people and companies in the built-environment sector. The start-up was founded by alumnae Julia Stöckert and Andrea Kaiser, together with Bea Baurecht. Job platforms already do exist, but none has an exclusive focus on the construction industry. With SKILLARY, the three young entrepreneurs have created a sector-specific recruiting network for architects, engineers, and companies. The start-up has been in contact

with UnternehmerTUM and the Architecture Research Incubator (ARI) since the beginning and has already sealed further partnerships.

The recently operational online platform combines two functions: On the one hand, the improved possibility to record accurately collaborations relating to new construction projects and relevant specialist qualifications in a virtual online database; on the other hand, an automated matching function assists registered talented persons with making the best choice for the perfect job and, the other way round, helps registered companies to find the best employee or cooperation partner – within Germany, but also in future across borders within Europe. Thus, the start-up offers two standardized profiles, one for architects and engineers, the other for companies.

BauHow5 Workshop on Equality, Diversity and inclusion in conjunction with Parity Talks IV at ETHZ

The Parity Talks IV, titled "Making 'Excellence' Work", took place at the Department of Architecture at ETH Zürich on March 07 and 09, 2019. The conference on gender parity in the architectural discourse brought together a variety of high-profile speakers and panelists from outside and within ETHZ. In conjunction with the Parity Talks, the annual workshop of the BauHow5 Equality, Diversity and Inclusion group took place.

Partners of the BauHow5 alliance include the Bartlett Department of the Built Environment of the University College London, the School of Architecture and Civil Engineering at Chalmers Institute of Technology,

Image: Architects made up as drag queens to promote Parity Talks series at ETHZ, like the Swiss duo Jacques Herzog and Pierre de Meuron, Honorary Doctorates of the TUM Department of Architecture. © Völlm+Walthert



Gothenburg, the Department of Architecture of the Swiss Federal Institute of Technology, Zurich, the BK Bouwkunde of Delft University of Technology and the Department of Architecture of the Technical University of Munich. With its aim to push boundaries of current practices in pedagogies, research and practice in Architecture and the Built Environment, the group is in its third year of sharing good practice in Equality, Diversity and Inclusion and collaborating in the development of new standards in architectural research and practice. The workshop in Zurich was the third gathering of the BauHow5 alliance in this field, following a Symposium in Munich, „Gender Unlimited“, in November 2017 and an international Conference „Building Diversity“ in Delft in May 2018.

Sustainable Residential Buildings on the Garching Campus

On the basis of the findings of a research association of the Technical University of Munich (TUM), the Studentenwerk München (Munich Student Union) is building three halls of residence for students on the Garching Campus. The buildings will be erected according to the principles of "simple construction" (Einfach Bauen).

Einfach Bauen is a research association at the TUM whose research projects are hosted within several chairs at the Departments of Architecture and the Department of Civil, Geo and Environmental Engineering. The participating scientists wish to provide a counterweight to the ever increasing complexity of modern buildings. Their strategies for simple yet energy-efficient and resource-saving construction include the reduction of building technology, a monolithic construction method, and a reduction of layers.

These principles are now being implemented on the Garching Campus. The three halls will provide space for up to 195 residential places. Built to the same geometry and size, they will be made of different materials: one out of lightweight concrete without steel, one out of solid wood, and one out of heavily insulating masonry. This will result in robust buildings that are precisely geared to the needs of the residents. As models for the "simple construction" principle, they will also be used for further investigations and long-term measurements. This trend-setting project is receiving support from the German Federal Environmental Foundation (DBU) with a grant of around €520,000. The following chairs are involved in the interdisciplinary research network "Einfach Bauen": Architectural Design and Construction (Prof. Florian Nagler), Building Technology and Climate Responsive Design (Prof. Thomas Auer), Timber Structures and Building Construction (Prof. Stefan Winter), and Materials Science and Testing (Prof. Christoph Gehlen).

TUM Architecture successful in BAM Ranking 2019

The Platform Best Architecture Masters (BAM) has revealed its newest ranking of the best post-graduate architecture programs in the world.

On the basis of the "QS Ranking by Subjects – Architecture / Built Environment", 30 universities were selected for the 2019 edition. TUM Department of Architecture reached the 6th position overall, with high ratings for the following indicators: consolidation in time / job opportunities & networking / publications / facilities / length vs. benefit / relation with other universities / teaching approach.

The global Top 10 is compiled by the following universities: Harvard, MIT Boston, ETH Zurich, UP Madrid, TU Delft, UC London, Columbia NY, TUM, Berkeley, and AA London. The result is derived from 13 educational-performance indicators, including quality and internationality of department, alumni, and postgraduate programs.

Establishing the Scientific Consortium "Architectural and Global Health"

Architecture is an instrument for improving human life. In the current times, when maintaining a healthy life – including with one another – is confronting people with complex global challenges, one discipline alone can no longer provide any improvements or solutions. With this in mind, the first German science consortium "Architecture & Global Health" was founded at the Center for Global Health of the TUM, within the framework of the third working meeting of the Department of Architecture of the Technical University of Munich, at the beginning of July 2019.

In the future, this interdisciplinary group of researchers will promote knowledge generation, as part of joint research projects, at the interface of the disciplines of medicine, psychology, architecture and health sciences. First and foremost, the development and testing of suitable research methods and designs is at the forefront. In addition, the association is seeking to develop, promote and support long-term, sustainable and quality-assured solutions as part of the increasingly complex issues faced by global health.

The initiators of the consortium are: Prof. Hannelore Deubzer, Architecture, Prof. Dr. Stefanie Klug, Health Sciences, Gemma Koppen, Architecture, Prof. Dr. Werner Lang, Architecture and Civil Engineering, Prof. Dr. Prazeres da Costa, Medicine, Prof. Dr. med. Tanja C. Vollmer, Architectural Psychology, Prof. Dr. Dr. Andrea Winkler, medicine.

Exhibition: CIRCOLUTION

Chair of Industrial Design, Prof. Fritz Frenkler

06.03.2019 – 31.03.2019

Why do we buy things we do not need? Why do we neglect the environmental aspects of designing, producing or consuming? How can we know what is best for the environment? Are there any concrete answers or an absolutely correct course of action?

The exhibition invited the visitors to ask themselves these questions and to think about the impact of their actions on the society, industry and economy of the future. It has shown ideas and realized projects that already deploy circular processes in certain phases. But closing the loop will require social change. It is only when each individual changes their mindset about consumption and reuse that the economy will change as well. We need to achieve a circular society in which we consider all the consequences of our actions and act accordingly.

CIRCOLUTION is the 8th "satellite" in a program series of Die Neue Sammlung – The Design Museum that deals with the FUTURO and visions of the future in design, film, literature, music, and performance. The exhibition was developed by students of the TU Munich (MSc in Industrial Design) and receives support from the Hans Sauer Foundation.

Course conception and realization

Dipl. Des. (Univ.) Hannes Gump
Dr.-Ing. Sandra Hirsch

The project originated in the Design, Communication & Society (DKG) module. The course was aimed at students on the Industrial Design (MSc) and Architecture (MA) Master's courses.

Die Neue Sammlung – The Design Museum

Dr. Angelika Nollert
Dr. Caroline Fuchs
Tim Bechthold

Students

Maria Ladygina, Tobias Leonhardt, Maria Le Quang, Tianxi Li, Hannah Lörzel, Felix Uhl, Stefan Weirich, Rebecca Weiß, Nina Winklhofer, Xuejing Xiao, Ren Yiran, Elmar Zapf, Franz Zünkler, Anna Theresa Braun

Images right: Maria Le Quang (In trash we trust, Save planet earth), Tobias Leonhardt (Sustainable, Bio-Siegel)
Images of the exhibition: © Daniel George

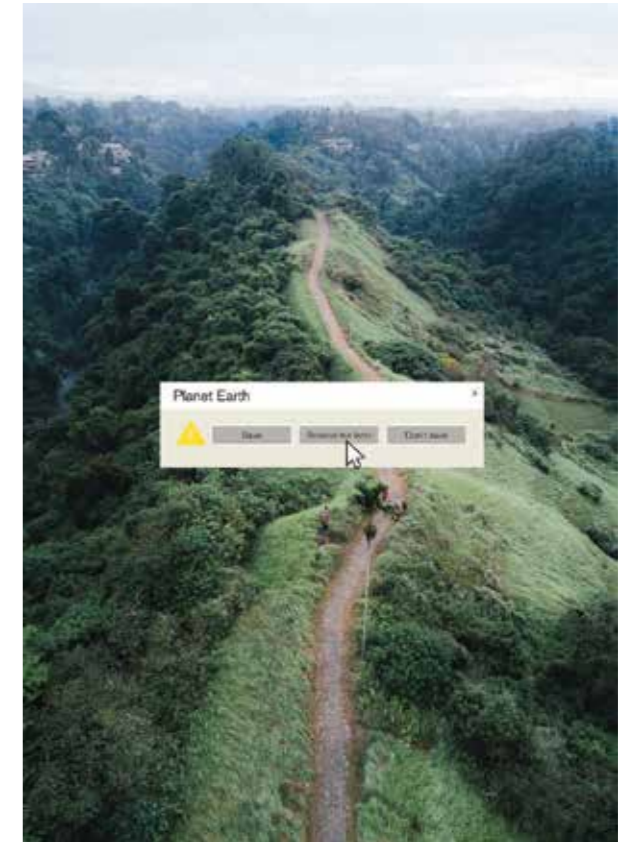
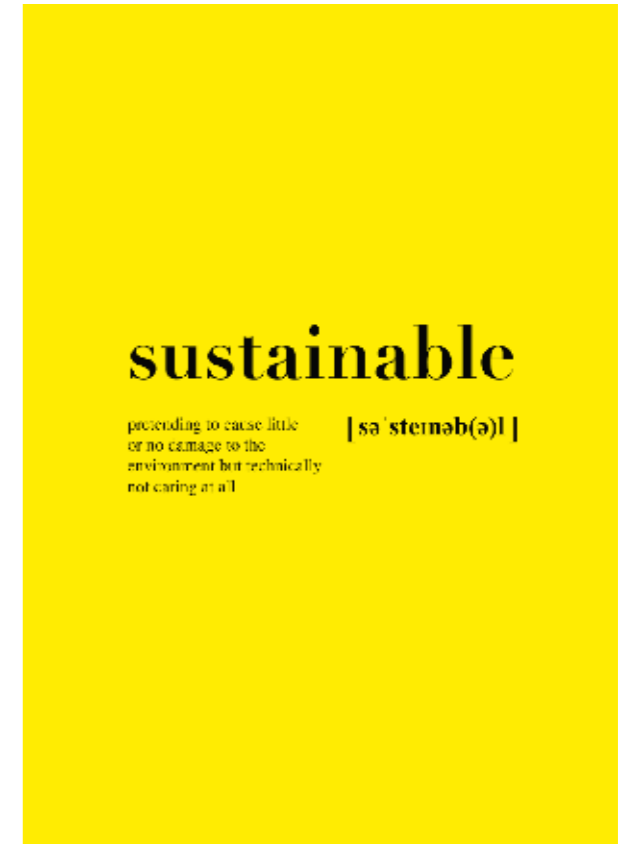
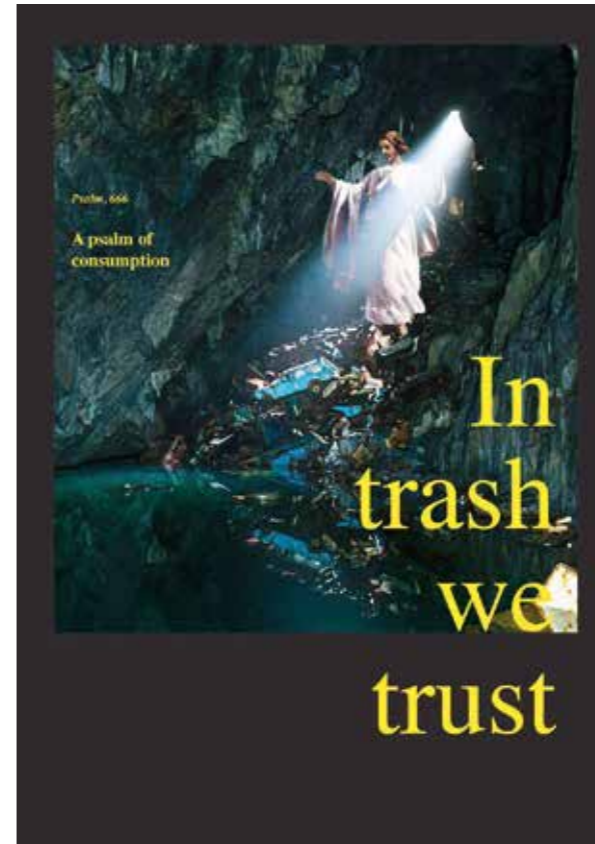

Laboratory for the Everyday City

Dr.-Ing. Benedikt Boucsein was appointed to the Professorship of Urban Design in the winter term 2018/19. He and his team have developed a manifesto in the Laboratory for the Everyday City.

Benedikt Boucsein, you have been Professor of Urban Design at the TUM for a year now. What attracts you to the task, why Munich and why this very prestigious chair?

I have always worked in tandem at the office and at the university, the two have influenced each other very strongly and it's an important combination. Since I had to end my assistantship at some point, but wanted to continue working in this double position, I applied for professorships. This is a game of which the outcome is uncertain and I was very lucky to land here at TUM. The basic motivation is to find myself between professional practice and academic work and, within the university, the triangle formed by teaching, research, and trying to be in the public eye. At the moment there are many urgent problems, but also many active people. Of course, I also find it exciting to work with the next generation and enjoy the luxury of freedom of thought. You have to keep reminding yourself what a privilege it is that we can pick and choose topics that interest us and work on them. You can't do that in the private sector as much as in the academic world. Especially not in architectural offices, if you still want to earn some money. I've always been more interested in urbanism because I had the feeling that there's still a lot you can have an impact on, how we live together, how we can continue to evolve.

The 14th German Architects' Day dealt with the socio-political responsibility of architects and urban planners for the quality, social cohesion, and sustainability of our built habitats. In your manifesto, you are demanding that our society should reinvent itself. How should this be done? How can architects and urban planners actively influence society?

Our manifesto, which is the result of a collective discussion in the professorship, deals with the question: What responsibility do architects assume in society? It is also strongly based on the ideas we formed at BHSF Architects since the formation of the practice. This position was also the idea behind publishing the magazine "Camenzind". That was an artistic project. Most architecture journals deal almost exclusively with an inward-looking technical discourse and we're saying that we have to be in the public eye and take the responsibility to explain ourselves. If we want society to grasp our concerns, first we must say what these concerns actually are and why we have a particular point of view. This was with us right from the beginning in our work at the office and we tried again and again to accept tasks that do not necessarily end up in some glossy magazine. I think it's a good thing when architects exercise their responsibility and also take on tasks that aren't usually part of their work.

What should this new urban society look like in Munich?

Of course no one knows. The authors Ulrich Brand and Markus Wissen have introduced the phrase "imperial way of life". This leads to an environmental footprint that is ten times higher than what is actually due to us in terms of global comparison. This has a lot to do with the city and its architecture, but above all with the way our society uses these cities. To put it mildly, it is irresponsible. To put it bluntly, we basically are committing genocide by living the way we live. Today the effects are already beginning to be very clear to see. People will lose their ancestral habitat, will be on the run and will die because we cannot hold back on our consumption and our travelling. Of course, we are not killing anyone forthright, but I think later generations will be quite harsh in condemning what we're doing right now. And the evidence is of course pretty overwhelming now, which was not yet the case 30 years ago, although back then we already knew everything there was to know. I would not even say that it is a requirement for our way of life to change: It will change inevitably. And either we shape this change now, or at some point it will be shaped by forces that we may not even want to be shaped by. All this has already started to slip away, it started long ago. In contrast to the 1970s, it is not enough to say that you have to shape things, today we are forced to do something. Of course, this is not so easy for urban planning, because urban planning works with completely different planning horizons, in decades, rather.

What could the new urban society look like? Of course, this will have to be negotiated by society itself. We can help by contributing our notions, ideas or specific perspectives. I think that there will be certain constraints: More togetherness, less separate coexisting, much less consumption, much less comfort, less travel, and hardly any fossil fuels. And I think it will also require much more negotiation because we will have to coordinate more things with each other.

But... actually: I cannot be very precise about it, and that's the reason for me to work at a university. I do not even know if anyone can say what it will look like in the end. Or whether we'll simply go into these transformations and try to help shape them in the studios and through the work with students. I don't think anybody can come up with a vision of what the city should look like in the end. And also, we had better be careful: In my dissertation I dealt with the architecture of the post-war period, when people thought that the "state-of-the-art," for example the "car-friendly city," would solve all problems. There are always blind spots, so in this sense I would be rather careful about specifying that it has to look just like so.

But basically, restrictions will be an issue, I'm sure about that. That may be very Protestant, and maybe does not fit well in Catholic Munich, but I think that in any restriction also lies an opportunity for society to reinvent itself. Greater cooperation, to which it will actually almost compel us. That you cannot run away from each other all the time and have to deal with each other more.

Which strategies must be developed to fulfill the core task of your professorship, namely the establishment and further development of the egalitarian European city?

A network is important so that we are part of a movement and collaborate with others, otherwise we cannot achieve anything. A research topic that interests us, for example, is the "Cooperative City". This means looking at aspects of urban society where one could think more collaboratively, both

within small cooperatives and in a wider context. The digital world will also certainly play a role, in coordination processes, in the negotiation of resource distribution. On the basis of what we already have, platforms will have to develop further in various cities, and of course they already exist in many cases. I think it won't be so much the buildings, but the way they're used, and the reinvention of public space, of street space, of movement across space. This may also constitute a difference compared to the generation before me, from which we learned a lot: They built at a time during which many new quarters came into being.

And to finish, the question of how do we deal with the fact that, as the current political debate shows, society may not yet be quite ready for change, but all the same, we can't go on as before? It could be a strategy to say that we prepare everything in our teaching and research, and when society realizes that it really has to change and nothing else is possible, then you can very quickly supply the solutions that you have previously rehearsed. Because, and that's also a lesson from history, at the end of the day you can't force change. As an urban planner, you're part of a wide historic river that's changing direction and you can only leap up, join in and influence the direction, but you can't force it to go upstream.

The so-called quadruple helix model of innovation is all about the relationships between politics, economics, science and a strong civil society. Who is in actual fact not yet ready for drastic change? Is the economy already much more willing than politics?

At the least, many in the business community are saying: Please change the basic policy parameters, so that we can adjust to the new situation. The political world is lagging way behind. I have the hope that society is more daring than politicians think. But they do not know about that exactly and that's why they are so careful about these climate packages.

But could that also be a job for the urban planner, for example, mediating between these four elements of the helix?

Ideally, the urban planning practice gets a study assignment or an exploratory planning study, and policy people are already involved, as well as all other stakeholders. I think we do have a responsibility to not always just pitch so that we'll get a great construction contract out of it in the end. Instead, on the basis of a planning task, we can also talk about what the goal of the next ten to twenty years is going to be. This is also what we try to practice in the studios, or to bring on a critical perspective to the Master's students. In this respect, the studios should not be overestimated – but not underestimated either. Basically, these are laboratory situations in which you can run scenarios. We have only one semester behind us and it was all about getting to know the students and the university, and practicing our modes of operation together.

At the United Nations Climate Change Summit in September 2019, there was a controversial debate on how innovation and technology could be reconciled with environmental awareness. What is your attitude towards this? Which basic parameters need to be changed from a political perspective?

We need both technology and society to be drivers of change. We are lying to ourselves if we feel that technology will save us. Because it won't! In addition, the question is, what does the technology look like? Like, as we often thought before, something that protects us, sets us apart from the

“Everything we do will always have some blind spots.”

Benedikt Boucsein

biosphere? Or is it something responsive, that thinks collaboratively? Then it gets quite interesting, but there will always be some blind spots. Everything we do will always have some blind spots. And, as far as our way of life is concerned, the big topic, which I always place at the beginning of the considerations and bring into the discussion, is reviewing the last seventy years. In the era of the so-called “Great Acceleration” since the end of the Second World War, all processes, our life in physical space, our movements, our consumption, our waste output and so on, have accelerated extremely – and the biosphere always reacts, with a temperature increase, species extinction, acidification of the oceans, and so on. This has nothing to do with ideology, it's natural science. And I think that if technology is called upon to sustain that acceleration, then it will go awry. But if it is meant to cushion us, and to carry us over into some kind of deceleration, into stabilization, then it will be of central importance. You can't always keep on accelerating. And even if we feel we can continue along this pathway through “green growth,” we will come to a dead end. At the same time, our systems are very much geared towards economic growth, and we can't turn them off overnight. These dilemmas will be with us for a while and the time for simple or painless answers is over, I believe.

In your „Laboratory for the Everyday City“ you are experimenting with new ways of living and working. What about some concrete examples?

There aren't really any student projects yet that could be depicted. We are only just starting and getting to know TUM. However, we have noticed that the issue is more difficult to get off the ground than we had thought. For many students, it is difficult to rethink, to break out of the mainstream stuff that they've heard until now, and to take up this invitation to think in absolute freedom in our Department.

This semester, with the undergraduates, we wish to demonstrate how an urban block here in the neighborhood is going to change over the next ten years. Scientists are saying: The next ten years will be decisive. It's too early to say whether the experiment will work, but we would like each team of two to appropriate two perspectives simultaneously: a plot-centered perspective, i.e. a house or an institution, combined with a meta-perspective in the sense of a high-level actor, for example elderly people, or children, or even nature. We are trying to set up the experiment in such a way that we can bring these two things closer together. If that works, I can well imagine that you keep going and try to complete detailed assignments and after a year you go back and set up a real laboratory. But of course, you must also meet with mutual appreciation on the ground. We shall see.

Manifest

And the focus of all this is on Munich?

First of all, we're focusing on Munich because all of us in the professorship come from outside Munich. It's an international team that is getting to know Munich. And all the predecessors of the professorship were also very strongly connected to this city. I actually think that makes sense and it's interesting. But in our research we also deliberately leave Munich, and we're trying to strongly internationalize here.

What will urban planners of tomorrow look like? What will their tasks be? In what ways should the training of urban planners change? Should it become more interdisciplinary or more adventurous? What will they have to be able to do?

Of course, keywords include: interdisciplinary, networked, flexible... Those things that urban planners notice and study in depth in our Department will definitely become more important in the future than they are now. High-level and interdisciplinary thinking, so that one can try and understand different disciplines, but always with the modesty to say that in the end one is "only" the spatial expert and only trying to bring everything together. I always ask the traffic planner, the social planner, and the landscape architects for their opinions and then facilitate the whole story. I don't even know if the urban planners of tomorrow will look that different from today's.

Maybe he or she should find their own assignments more often, and that's something we want to bring more into the teaching in the medium term. In practice, there are always people who do that. People who are not content with always getting told what to do. Rather, one sees a problem and creates a job for oneself.

I also believe that we will have to improvise a lot in the future, and you always had to do that as an urban planner anyway. Because you will come into situations where you know from the beginning that you will never fully understand everything. You have to be humble, but still devise a strategy. This will be a quality that is needed in the future as well. Another thing that we definitely practice a lot at the office, that's working on a par with landscape architects, sometimes we also let them steer. I see that as a real strength of the Department, that we have four landscape professorships, it's something that we all could, or should, capitalize on a lot more.

It's extremely important to have this perspective in urban planning, be it with regard to urban climate aspects, be it the fact that nature in the city is already substantially more diverse in terms of species than in the countryside, be it on such specific issues as the greening of façades, roof gardens, and the amenity value of public spaces. Because one thing is certain, the city of the future must and will be much greener than today.

Hanne Rung

We are at the end of an era that has lasted over seventy years, the 'Great Acceleration', during which human impact on the environment accelerated at an unprecedented speed, driven by technical developments, economic interests, and related ideologies. The warning light for this era is flashing, as predicted over forty years ago by the Club of Rome: we are experiencing a global crisis of ecosystems and, as a result, the gradual loss of our basic living resources.

Global warming is just one of many consequences of a lifestyle that displaces its negative impacts to other regions and countries. This lifestyle cannot be maintained, even with a technological transition or 'green growth', and its consequences are already beginning to catch up with the main polluters – ourselves. Hence, our way of life must and will change radically – for ecological, moral and, ultimately, economic reasons. A radical move away from further acceleration is not an ideological demand but a highly rational one. Thus, road and air traffic will have to be strongly reduced, our diets will have to follow other imperatives, and the growth of GDP or the DAX can no longer be equated with progress. Our societies need to reinvent themselves.

At the heart of this process stands the egalitarian city project, whose further development is the core task of our Professorship of Urban Design at the Technical University of Munich. Indeed, our cities draw their vitality from openness, equal opportunity, and the appreciation of the public good and public space – and the creative expression of these values. In order to preserve these qualities during the impending crisis, it must be anticipated, including in aesthetic terms but, at the same time, strategies aiming to maintain this openness need to be developed.

It is the government's responsibility to usher in the imminent transition by courageously changing framework conditions and conveying to the population the vital significance of the current situation. Our contribution entails identifying the situation from an urban perspective, developing knowledge, and pointing out the new ways in which European cities can be further developed. Post-Acceleration Urban Development is being invented and discovered right now.

To this end, we are building a network of like-minded individuals and organizations, with whom we will work together as partners on projects and alliances. In addition, we are preparing the next generation of architects and urban planners for the impending changes. To accomplish this, we will also have to become pioneers of a new way of life and changing world of work.

On the occasion of the appointment of the new Professorship of Urban Design at the Technical University of Munich, we are launching the 'Laboratory for the Everyday City'. For we are at the beginning of a new era and, thus, of a new mode of organization of our everyday life. This may, despite the circumstances, still lead to improvement in more people's lives. The laboratory is the experimental space for this new everyday. It is open as a partner organization to all those who wish to positively shape the new era together with us. Thereby, the way the lab will work will itself constitute an experiment, that we will document.

These principles will be followed in the laboratory:

- We will work in a transparent way and publish our results according to the 'open source' principle
- We will report annually on the impact of our activity on the planet and build partnerships with compensation projects
- As the Professorship, we will fly as little as possible, and not at all if we can reach a destination in less than ten hours by train
- We will teach and promote cooperative ideas and shared-use principles as a form of knowledge that is important for the future
- We will work in public space and involve the public
- We are committed to the city of Munich as a community and will work towards concrete changes on the ground
- We will also constantly connect the search for the new everyday life with issues related to design and urban space.

We will scrutinize, expand and modify these principles. For we may well write manifestos, but are far from being dogmatic!

Laboratory for the Everyday City, 2019

Benedikt Boucsein, Elettra Carnelli, Elif Simge Fettahoglu-Özgen, Isabel Glogar, Michael Kraus, Olga Wiedenhöft, Daniel Zwangslleitner

Knowledge-intensive firms, connectivity and spatial restructuring: dynamics and differences in Germany and Switzerland

PROJECT INFORMATION

Project partners

Chair of Urban Development
Prof. Dr. Alain Thierstein, Mathias Heidinger,
Christiane Müller, Fabian Wenner

Subsidized by

German Research Foundation (DFG) and
Swiss National Science Foundation (SNF)

Duration: 01/2017–12/2020

From 2017 until 2020, the Chair of Urban Development, together with the Lucerne University of Applied Sciences and Arts, is working on the research project ‘Knowledge-intensive firms, connectivity and spatial restructuring: dynamics and differences in Germany and Switzerland’, funded by the German Research Foundation (Deutsche Forschungsgemeinschaft – DFG) and the Swiss National Science Foundation (Schweizerischen Nationalfonds – SNF). The project raises the following research question: what has been the influence of the financial and economic crisis, which peaked in 2009, on the spatial value creation process in Germany and Switzerland? It uses a temporal longitudinal analysis to investigate the location dynamics of companies in the knowledge economy.

The financial and economic crisis led to a decline in global economic output for the first time in the post-war period. Export-oriented countries and open economies were particularly affected by the repercussions of the crisis. Usually, this type of crisis modifies interrelations within the economy, especially as regards company location decisions. We assumed that the crisis had led to a concentration of knowledge-intensive activities in urban areas, thereby further accelerating spatial structural change, because urban areas possess the strongest innovation drive and greatest capacity to overcome the repercussions of the crisis. This, in turn, has had consequences for the financial stability of municipalities, the attractiveness of cities as locations for living and working and, ultimately, for urban planning and architecture.

In this project, a special database of company locations has been built; by means of a temporal longitudinal study, it has been analyzed and visualized. We gathered the global business locations of approximately 480 companies in 16 different branches of the high-tech industry and business services sector, such as consulting firms. This was done for the years 2009 and 2019. It not only allowed us to consider location-based issues, but also to analyze the embedding of cities as nodes within international corporate networks – and thus, within knowledge networks.

However, contrary to expectations, initial results for Germany do not show any concentration of company locations in urban areas after the crisis. On the contrary, there is a spatial spread, while the largest metropolitan areas have been stretched to their limits in terms of the number and importance of established companies. In particular, small and medium-sized cities in the

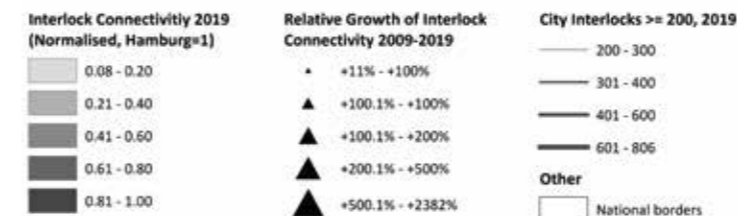
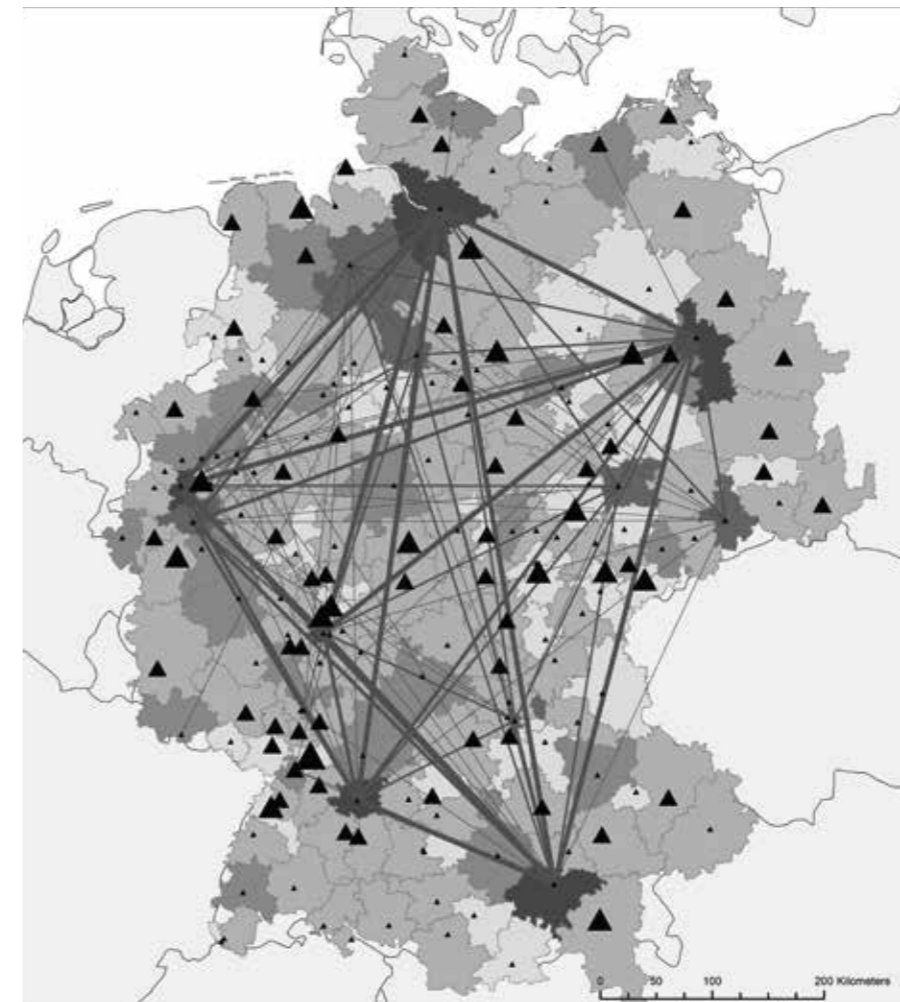

‘second belt’ around large metropolises have benefitted from the local growth of business service providers, for instance Landshut or Schwabach but also university cities and those outside the ‘Big Seven’, such as Leipzig, Karlsruhe, Bremen and Münster. Peripheral regions also exhibit strong relative growth, albeit from a low initial level. Our current explanation for this phenomenon is that a ‘spillover’ of activities away from metropolitan centers has taken place, due to the very high cost of labor and real estate there. By contrast, industrial towns in a transitional phase, such as Hagen, Duisburg or Ibbenbüren, have stagnated in terms of their involvement in company networks.

High-tech sector data collection is also expected to be completed in 2019, so that more detailed results can be published in 2020.

Fabian Wenner

“In particular, small and medium-sized cities [...] have benefitted from the local growth [...]”

Project: Municipal Stadium on Grünwalder Straße
 Chair of Architectural Design and Construction, Prof. Florian Nagler

In the summer of 2017, the professional football team of the TSV 1860 Munich returned home to the Giesinger Berg. The Sechzger stadium has been part of Munich's sporting history for over hundred years and is a landmark of Giesing. On match day, hours before kick-off, an atmosphere of expectation prevails in the district.

In contrast with sports grounds on the edge of the stand on the periphery of the city, which have been honed for road traffic, city stadiums like the Sechzger display a very special urban flair. Countless pubs in the direct vicinity of the stadium, the uncomplicated journey by public transit, along with the enjoyment of public open spaces, are emblematic of an urban lifestyle.

According to their wishes, the professional players of the TSV 1860 Munich continue to play their home games in Giesing. Should they climb back up into the 2nd or 1st Bundesliga (national league), then they will offer at least 15,000 spectator seats. In March of this year, the City of Munich commissioned a feasibility study for this purpose.

As part of the semester design project, we wished to investigate future expansion options for the Municipal Stadium on Grünwalder Straße as a match venue for the first and second leagues. In addition to conditions imposed by the umbrella organization (German Football League), building legislation and infrastructure challenges must be dealt with and, last but not least, the interests of local residents must be respected and their protection has to be ensured.

Image below: Florian Happes and Otto Kehrler, undergraduates

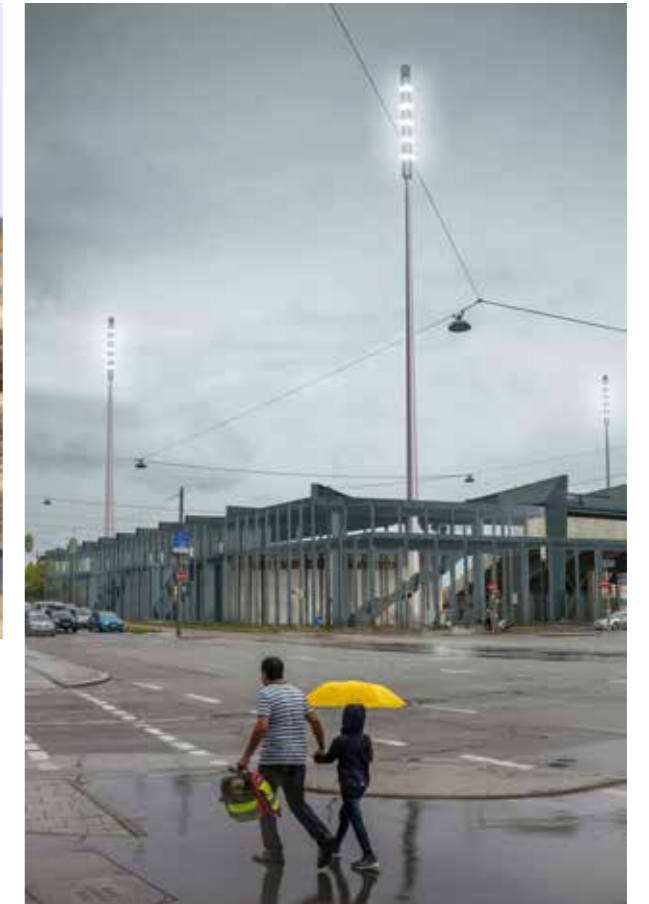

Image above + right: Model photograph and rendering by Lukas Vallentin and Johannes Daiberl
 Image below: Rendering by Cornelius Buhl and Mohamed Elyes Zahrouni





Image above + right: Katrin Wolf and Bianca Kelp



“[...], city stadiums like the “Sechzger” display a very special urban flair.”

Image below: Konstantin-Elias Schöffler-Fidelis, Lena Lämmle and Dimitrios Vanis



Women in Architecture

For their Parity Talks the Architecture Department at ETHZ worked with local graphic designers Völlm+Walthert to feminize the portraits of architects. We asked Professor Hermann Kaufmann for collaboration.

Illustration: Lisa Bamberg, © TUM Department of Architecture

PROJECT INFORMATION

Project partners

Professorship of Architectural Design and Timber Construction (TUM) Prof. Hermann Kaufmann, Sandra Schuster (Project Management), Anne Niemann, Mirjam Elsner

Professorship of Gender Studies in Science and Engineering (TUM GOV), Prof. Dr. Susanne Ihse†, Dr. Tanja Kubus, Jenny Schnaller, Elisabeth Wiesnet

Department of Sociology and Gender Studies (LMU), Prof. Dr. Paula-Irene Villa Braslavsky, Marlene Müller-Brandeck

Subsidized by

Technical University Munich

Gender & Diversity Incentive Fund (GDIF) from the budget of the Exzellenzinitiative of the Federal Government and the Länder

Duration: 01/2018–12/2018

Download of report, including appendix: go.tum.de/106005

A study for the development of a third-party funded research project on gender-equity changes in terms of the professional culture in architecture

The educational situation for women at German universities and colleges is good. Undergraduate numbers have been increasing for years. The proportions of women and men have been at an almost equal level since 1998; however, men and women are spread differently among different study programs. Within architecture studies, the proportion of women is now much larger: in 2006, for the first time, as many men as women studied architecture in Germany, while by 2016, 58% of architecture students were women. Against this background, the question arises which paths female architects take after completing their studies. The high percentage of female graduates is reflected neither in management positions in architectural practices nor in the academic field: in 2017, among the top 20 architectural firms in Germany, not a single office was run by a woman alone or a team of women. At the same time, the income of full-time female architects is almost 30% lower than that of their male counterparts.

The study ‘Gender Equality in Architecture’ investigated the directions in which female architects developed and whether there was a structural drop-out that might prevent women from entering the profession or from reaching leadership positions owing to exclusion mechanisms founded on sectoral culture. To this end, existing data and statistics were analyzed and interpreted. It turned out that data availability was very thin and patchy. Based on expert interviews, deeper insights into the sectoral culture were achieved. For this purpose, both female and male architects working under different types of employment relationship were interviewed, as well as persons who had studied architecture, but did not practice within the profession.



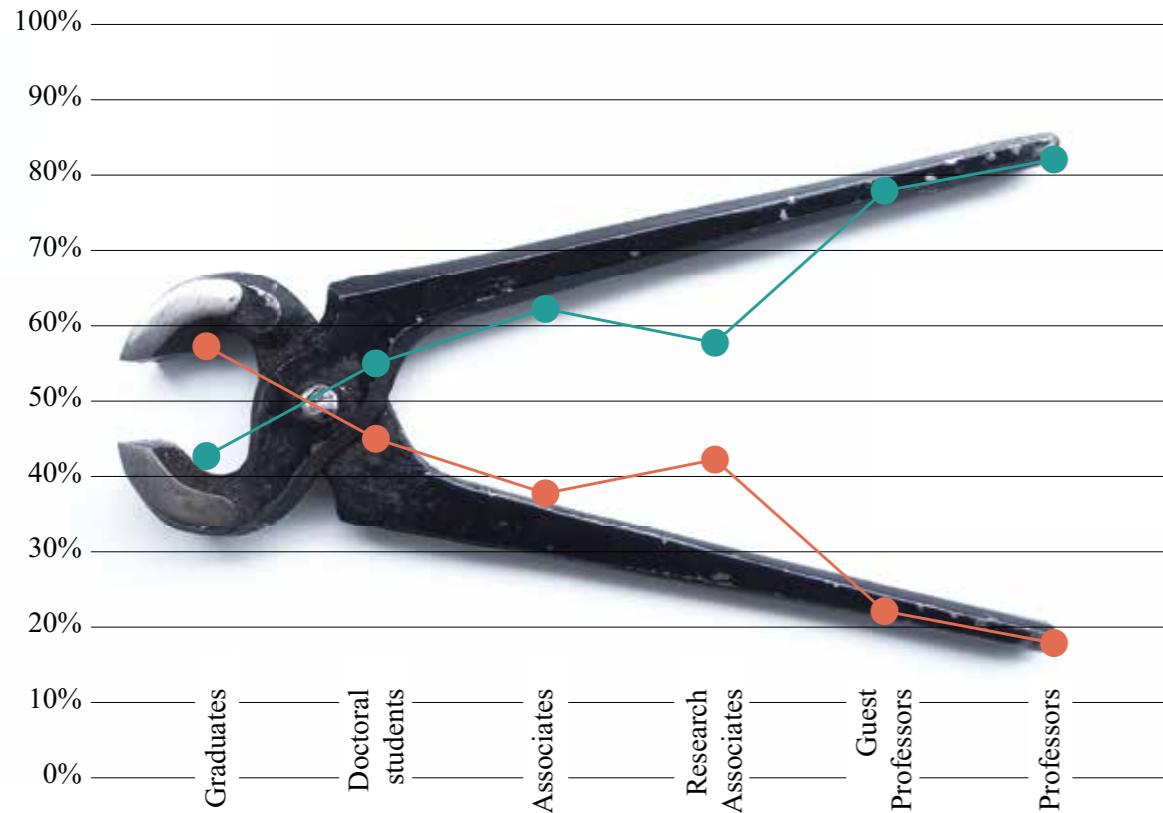

Scientific staff in architectural sector (2014–2016). Source: TUM
All graphics by Lisa Bamberg, © TUM Department of Architecture

Female architects at universities and colleges

Part of the study examined the figures at the Department of Architecture of the Technical University of Munich. These findings should serve to develop measures that will be applied and tried out in the context of the diversity-oriented target agreements with the TUM. So far, there has been no continuous, digital data collection on gender distribution at the Department of Architecture. Data collection is imperative to assess the status quo as a basis for the implementation of the gender equality goals of the Department and is strongly recommended within the framework of the study. For this reason, only a snapshot of the situation can be provided, not the overall trend. This snapshot definitely shows that there is an urgent need for action.

Figures from the years 2014, 2015 and 2016 were used as a basis to report on the proportion of women at various stages of scientific work at the Department of Architecture of the TU Munich. The picture obtained is comparable to that concerning women in a typical academic career path in the EU (see She-Figures): if, at the first stage of academic education, women still constitute a large majority of students and graduates, this begins to reverse at the doctoral stage. The gap in the proportion of women in middle-level scientific positions then widens. The obvious discrepancy indicates that action is strongly needed at the Department of Architecture in order to reduce the gender gap at the highest levels

of the academic career path. Non-standardized application procedures and career paths in the architecture industry complicate these processes. This applies both to some colleges of the university and to professional practice: vacancies are often not advertised, but passed on through personal acquaintance and word of mouth.

Data collection, and the associated voluntary commitment to monitoring, will constitute an important step towards change. As regards hiring middle-level scientists, it is possible to actively work towards parity without too much effort. The same applies to the recruitment of graders. The attribution of an equal number of visiting professorships is already being actively promoted by the dean's office. Within the framework of appointment procedures, it will be necessary to work vigorously towards equal representation on committees. However, a professional approach to the gender and diversity issue is at least as important. For this purpose, training courses are available for all those who take part in an appointment procedure. Lectures and expertise on this subject should additionally also be established within the Department. These measures are necessary in order to avoid the implicit gender bias that is still a feature of the scientific world. Gender bias means that women and men are (usually unintentionally and unconsciously) considered, treated and evaluated differently in scientifically relevant aspects such as performance, competence, etc., even if there is no objective justifi-

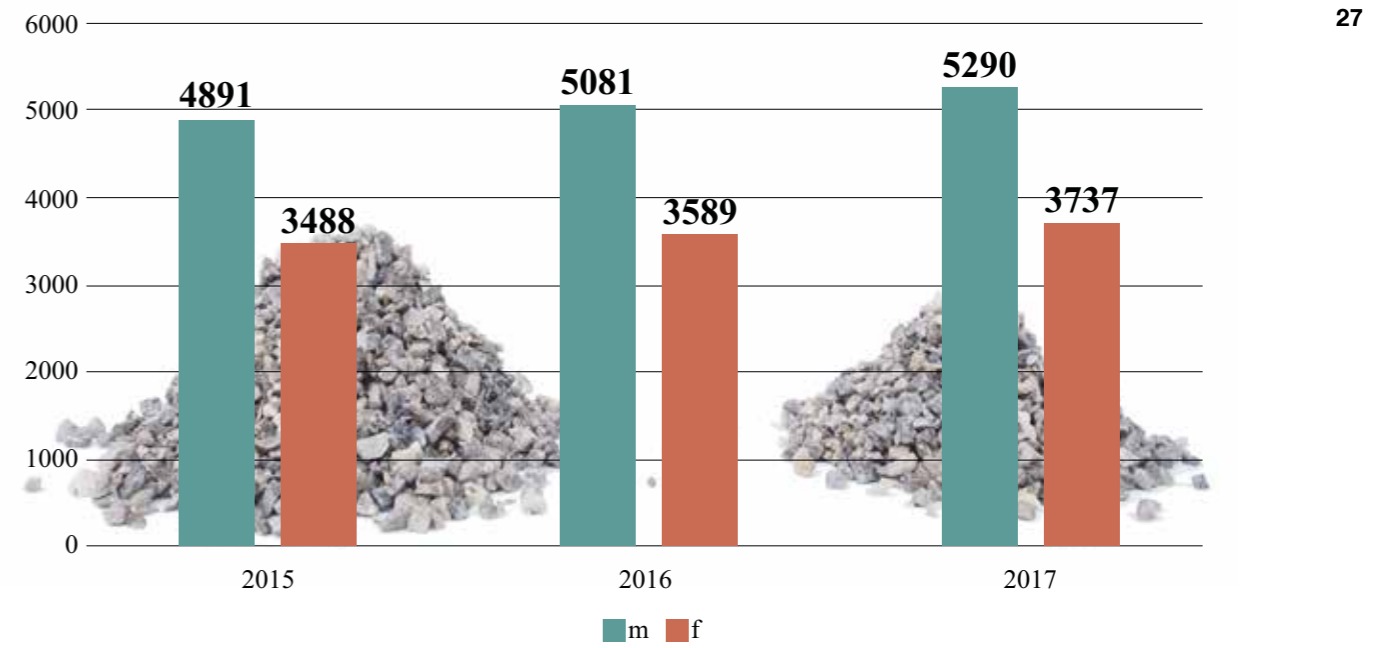

Level of average gross monthly earnings of full-time employees by gender in euros. Source: Federal Statistical Office

cation for doing so. A special emphasis must be placed on the active recruitment of possible female candidates, also within the equality monitoring of appointment procedures at the TU Munich.

The large number and variety of open research questions show that there is a need for further research. At the same time, the empirical and quantitative evidence presented and visualized in the study make it very clear that gender in the architectural profession is an issue that will not sort itself out by simply waiting. The available information must already act as an incentive for change and the development of a new culture in the architecture industry.

An absence of female role models

Essentially, there seems to be an under-representation of female executives as role models within the architecture industry. Female architects who do occupy a leadership position in an office are less likely than male architects to be given the opportunity to perform in public and thus receive attention and recognition for their work. Within the organization, they play a crucial role for the success of the office, but lack standing in the public eye or in terms of the professional culture. Female architects who run an office together with male partners often suffer from a misjudgment of their position. The public invisibility of female architects who either run their own offices or are involved as partners results in

a shortage of female role models for female students and young architects (Schumacher, 2004). Female students and architects need female role models in order to trust themselves to assume positions of leadership. Examples of positive career paths also open the door to the opportunities for shaping one's career and to strategies for coping with the specific challenges that female architects have to deal with. As already shown, female professors at universities are also outnumbered, hence there is already a lack of female role models during the course of study (Schumacher, 2004). Afterwards, developing confidence in one's own abilities and competence is decisive for finding a career and receiving promotions. For only people who are convinced of their own abilities can also radiate this outward into everyday life at the office.

Architectural practice

Students have much difficulty in gaining a picture of their future profession, since they often do not have any practical work experience yet. The respondents' conception of everyday working life is more positive than the day-to-day work of an architect actually turns out to be. During the course of study, however, a positive picture is maintained, since reactions, including outside the university environment, tend to be positive when studies or profession are mentioned. Owing to the self-portrayal of the mostly male university teaching staff in the field of

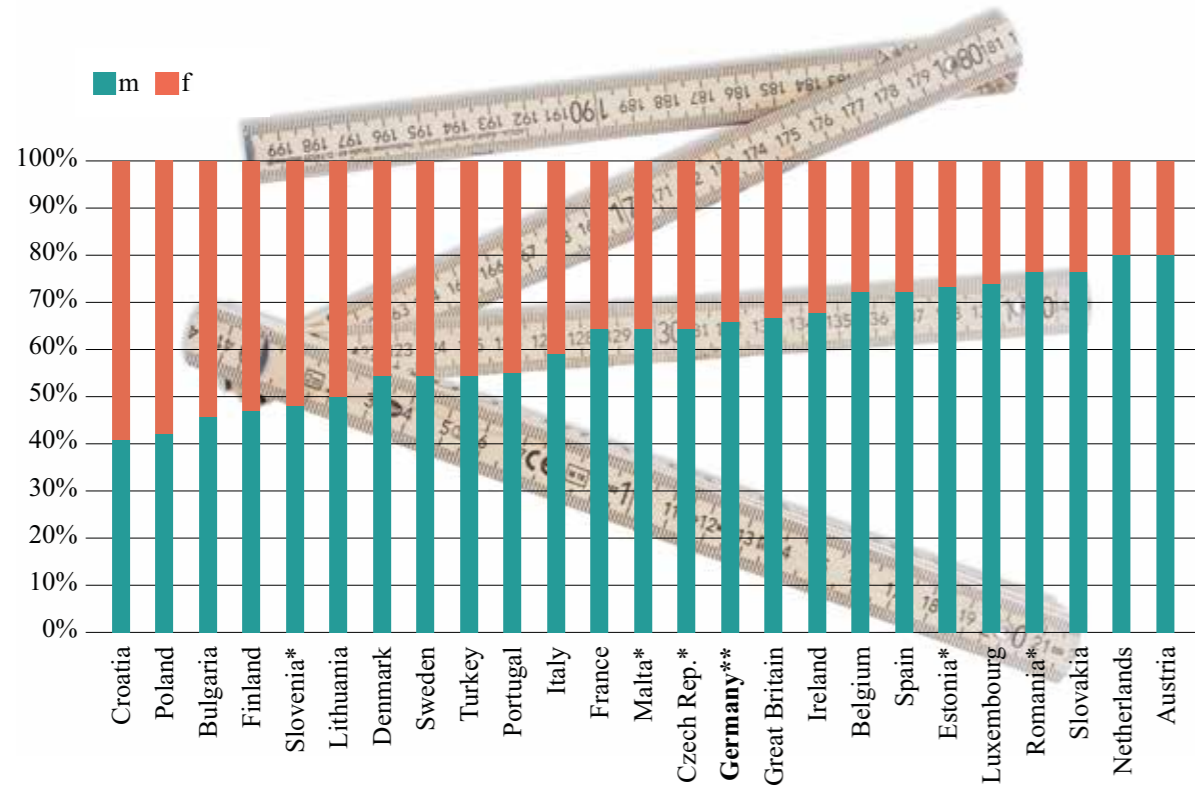

Gender distribution of architects in Europe. Source: Architects' Council of Europe

architecture, the ideal image is charged with male characteristics: it often creates a kind of student-master relationship, in which it is difficult for students to separate the characteristics that they connect with their teachers from their teachers' gender (Schumacher, 2004). Here, too, the aforementioned lack of female role models in universities and in executive positions in architectural firms exerts an influence, since architecture students have little opportunity to connect their expectations with female role models.

In Germany, women earn less than men in all occupational categories. Indeed, according to a study by the Hommerich Research Institute, female architects and planners earn just about 30% less than their male counterparts (statista). The statistics presented here show the average gross monthly earnings of full-time employees in the 'architecture and engineering offices' sector in Germany for the years 2015 to 2018 by gender; they clearly illustrate the gender pay gap in the industry. Further figures show that the pay gap already exists right from the beginning of employment – this clearly points to unequal treatment of women and men. For upon completion of their studies, their levels of knowledge are generally comparable and issues such as interruption of working time, part-time employment, etc. are irrelevant.

Working hours, part-time

With regard to the establishment of new, flexible working-time models, the architecture industry is not proving very innovative. The architectural community is still very much attached to its traditional professional image, which entails long hours at the office. The "part-time work" model primarily serves women. Part-time work is often associated with tasks carrying little responsibility and demonstrably excludes (women) from leadership positions. Other working time models, such as job sharing, are either hardly or not at all to be seen in architectural offices. Here, some rethinking would be useful and vital: Chambers and professional associations are considering the issue of flexible working hours, including in terms of the economic aspect.

Judging by the interviews conducted, building authorities seem to be a popular workplace for many women. One reason for the high number of women working at (building) authorities may well be their better structural organization: Regular working hours, overtime reduction, and an easier return to work after parental leave make building authorities an attractive and secure workplace. At the same time, the interviews also clearly display prejudices against working for building authorities. Working for a public authority is considered to be much less demanding. Although security is pro-



Gender distribution of structural architects in the Chamber registered by activity. Source: Federal Chamber of Architects, 2007–2017

vided, such work apparently does not leave any room for a real passion for architecture. One may wonder to what extent the structures of a public authority could be transferred to architectural firms. In this context, we may question not only the difficulty of reconciling family and career, but also the established professional habitus, which leads to a complete dissolution of boundaries between private and professional lives.

Conclusion

The large number and variety of open research questions that the study has identified and formulated show that there is a need for further research. At the same time, the empirical and quantitative evidence presented and visualized in the study make it very clear that gender in the architectural profession is an issue that will not sort itself out by simply waiting. The available information must act right away as an incentive for change and the development of a new culture in the architecture industry.

References

Schumacher, Christina (2004): Zur Untervertretung von Frauen im Architekturberuf.
 Bern/Aarau: Forum Education and Employment, Swiss Koordinationsstelle für Bildungsforschung.

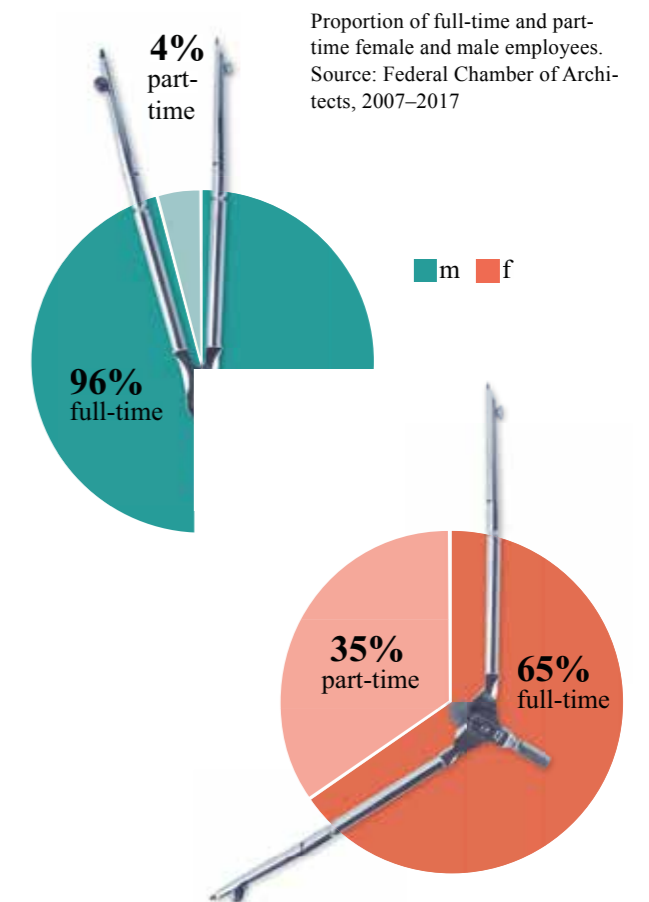

Proportion of full-time and part-time female and male employees. Source: Federal Chamber of Architects, 2007–2017



**Exhibition of the
Master's Theses
2018/19 in the TUM
Inauguration Hall**

Picture: Lisa Henicz © TUM Department of
Architecture



Seminar / Symposium: ACTION, INTERVENTION, PARTICIPATION – art and interim use as participative planning – (how) does it work?
 BA/MA Summer Semester 2019
 Chair of Landscape Architecture and Public Space, Prof. Regine Keller

In the search for new participation methods, the focus is on art and interim use. Planning authorities have been commissioning artists, architects, and event organizers to experiment with public spaces.

As part of a study seminar for landscape architecture students, current temporary installations and actions within a planning context in Munich's public space were researched in spring 2019. The project collection will be permanently documented and made available on the INTERVENTION-MUC website (web7.wzw.tum.de/intervention-muc).

The results of the research were presented at a public symposium of the Vorhoelzer Forum. Four Munich protagonists from different disciplines presented and discussed their own approaches and projects.

Image above: "Container Collective" – installation as an event location, by Robinson Kuhlman, Neville Kuhlmann and Markus Frankl. © by Johann- Christian Hannemann, TUM, 2019
 Image right: "Alte Utting" – installation as an event location in the Schlachthofviertel, by Daniel Hahn. © by Amelie Kessler, TUM, 2019



- Tutors / Curators**
 M.Sc. Johann-Christian Hannemann, Dipl.-Ing. Felix Lüdicke
- Students**
 Melissa Apolaya, Carina Brandl, Gero Engeser, Caren Huckle, Amelie Kessler, Christopher King, Fabian Konopka, Beatrice-Katharina Leitner, Robert Rothe, Rafael Stutz, Victoria Wakulicz
- Speakers**
 Prof. Dr.-Ing. Agnes Förster, organizer: Julian Hahn, Dipl.-Ing. Florian Otto, Dipl. Culture Pedagogue / Dipl. Artist (FH) Alexander Steig
- Podium Guests**
 Dipl.-Geogr. Ursula Caser, Dipl.-Ing. Stefanie Jühling, Prof. Dipl.-Ing. Kerstin Langer, Dipl. (ADBK) / M.A. Stefan Wischnewski

Image left: Seminary – Workshop at Kreativquartier. Photograph: Johann-Christian Hannemann, TUM, 2019
 Image below: "Piazza Zenetti" – installation as a planning process on the Zenettiplatz, by raumzeug. Photograph: Rafael Stutz, TUM, 2019



Observe & Conserve OLYMPIC FOLLIES

Kiosk Buildings in the Munich Olympic Park. Documentation, 3D Photogrammetry, Analysis and Conservation Strategy

PROJECT INFORMATION

MA Exercise – Summer Semester 2019

Project partners

Assistant Professorship for Recent Building
Heritage Conservation
Prof. Dr. Andreas Putz
Meltem Cavdar

Chair of Conservation-Restoration, Art
Technology and Conservation Science
Prof. Dr. Thomas Danzl
Dr. Clarimma Sessa
Nadia Thalgueter

The objective of the exercise was to document and analyze the ticket booths in Munich's Olympic Park. These consist of a series of similar buildings erected in the early 1970s in a modular way by the young architectural group PAS (Jochem Jourdan, Bernhard Müller and Rasem Badran).

Modularity was an idea that Jourdan had already addressed in the late 1960s in his work as a scientific assistant at the Technical University of Darmstadt. Rasem Badran, one of the participating students, who worked with Jourdan and Müller on the kiosk and ticket booth project for the Munich Olympics, later became one of the leading architects involved in urban rehabilitation in the Near East.

The idea for the project was developed with Carlo Weber, who coordinated several architectural teams within the overall scheme by Günter Behnisch. The first design proposed plastic structures but, for economic reasons, in the end these were made of steel frames covered with aluminum panels. PAS suggested using tube systems for the construction instead of extruded profiles because production would be less costly. Acrylic glass, also known as Plexiglas, was used for the windows, roofs and signboards.

Image below: elements of the ticket booths, by Pietro Sircana, Lucrezia Rodriguez, Livia Calcagni, and Chiara Saccomanno

WALKWAY ELEMENTS

Type A: Straight Elements

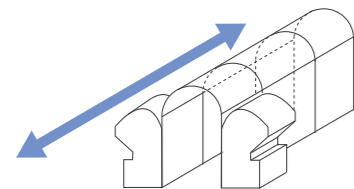

Type B: Angular Elements

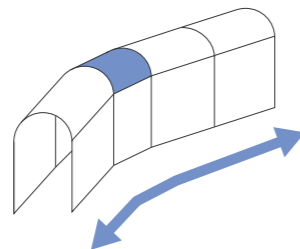

Type C: Angular Elements

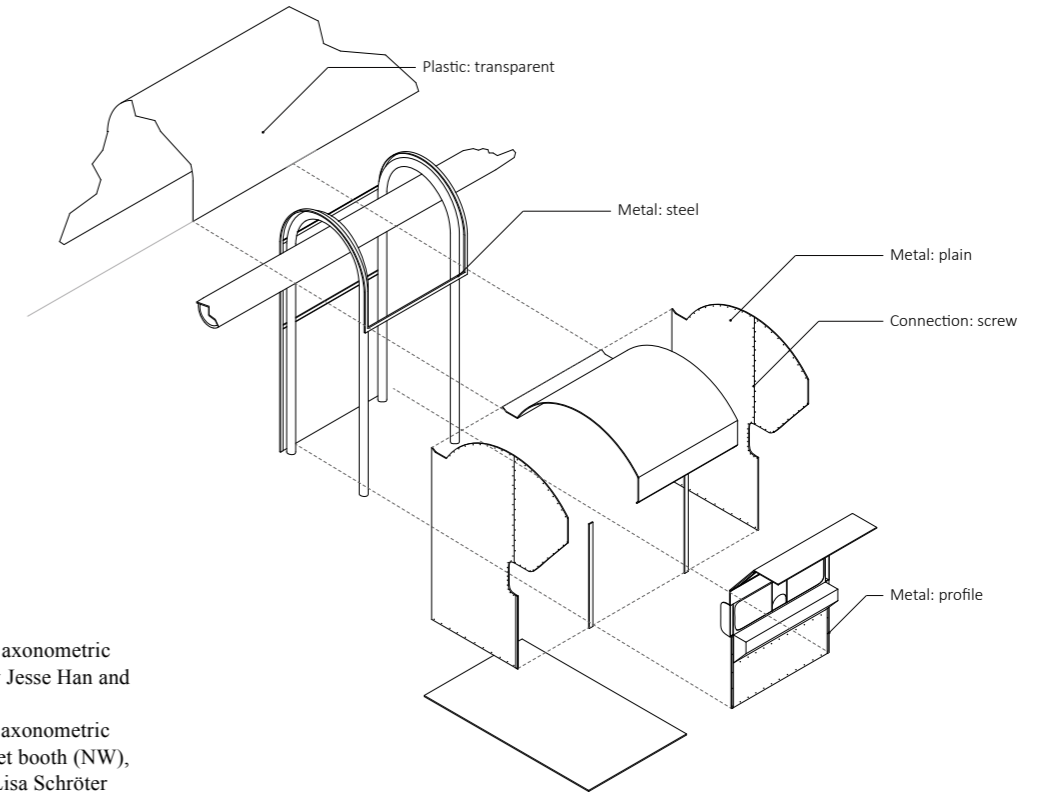
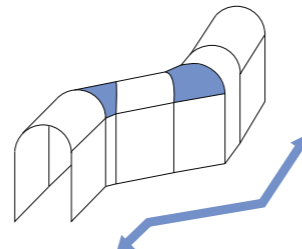
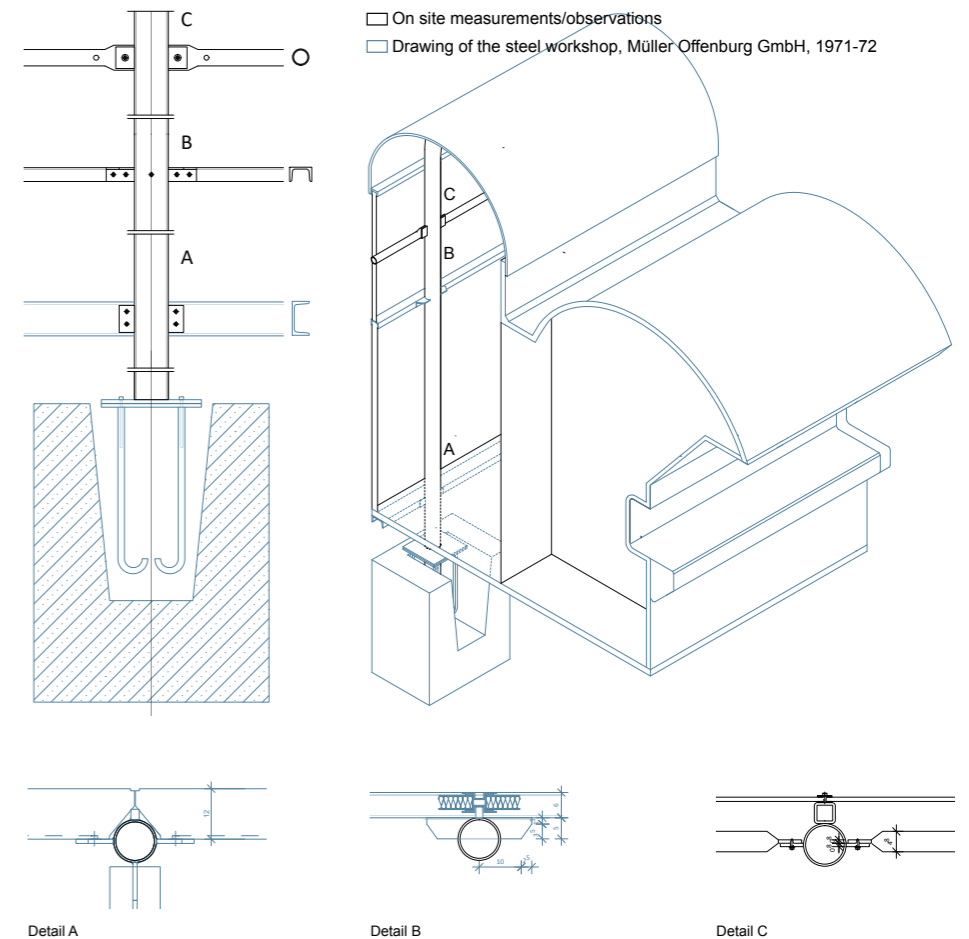

Image above: exploded axonometric view of ticket booth, by Jesse Han and Mu-Yen Lee
Image below: cut away axonometric view and details of ticket booth (NW), by Jana Calatrava and Lisa Schröter



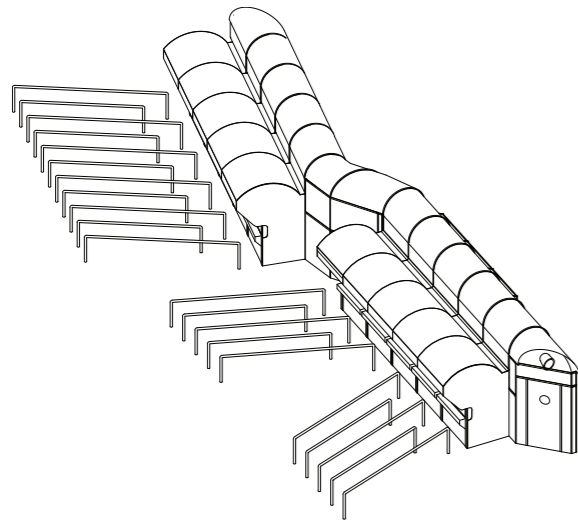

Image left: axonometric view of ticket booth (SW front), by Jesse Han, Mu-Yen Lee
 Image below: mapping of ticket booth (NW), by Jana Calatrava and Lisa Schröter

The students' research during the semester was based on the original building plans and on-site investigation of the objects, which had strongly altered. The aim was to create a basic structural and material documentation, and analyze the objects, in order to develop a long-term preservation and management plan. The students were introduced to 3D photogrammetry, using 3DF Zephyr for object documentation purposes. The photogrammetric documentation was further used for a phenomenological mapping of the building materials and of surface deterioration and decay. In addition to the analysis of the original construction plans, on-site measurements and axonometric documentation of the structures in line drawings enabled a better understanding of structural

damages, recent repairs, and alterations. Investigating the structures' materiality further, and based on the previous findings and mappings, we concluded with a discussion of different ideas for developing a conservation and management strategy for these fragile structures.

The output of each student group was summarized on individual posters. These will be combined to produce a final, comprehensive outcome to be presented at the student poster session during the ICOMOS International Conference 'The Heritage of the Modern Olympic Games' in November 2019 in Munich, alongside other posters from various universities.

- Metals
- 1. Aluminum
 - 1a panel
 - plan
 - strip fluted
 - paint-coated
 - 1b profile
 - 1c bumper
- 2. Steel
 - 2a beams
 - hot-dip galvanized
 - paint-coated
 - 2b screw
- Polymers
- 1. PMMA
 - transparent
 - paint-coated
 - foil-coated
- 2. Elastomers (natural rubber)
- 3. Textile

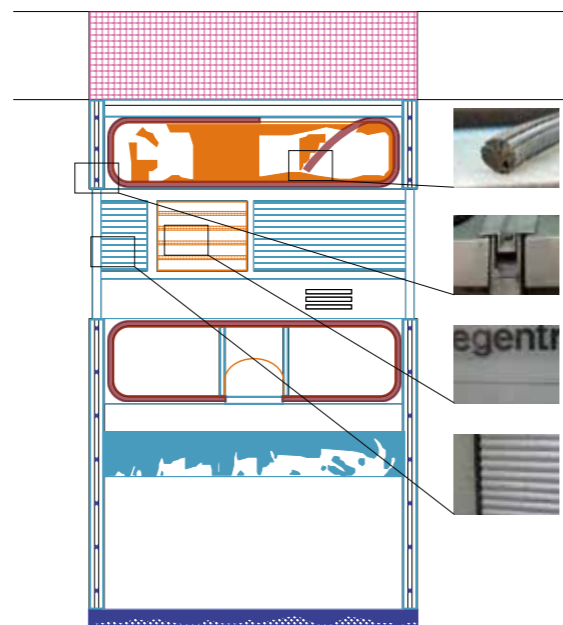

“[...] developing a conservation and management strategy for these fragile structures.”

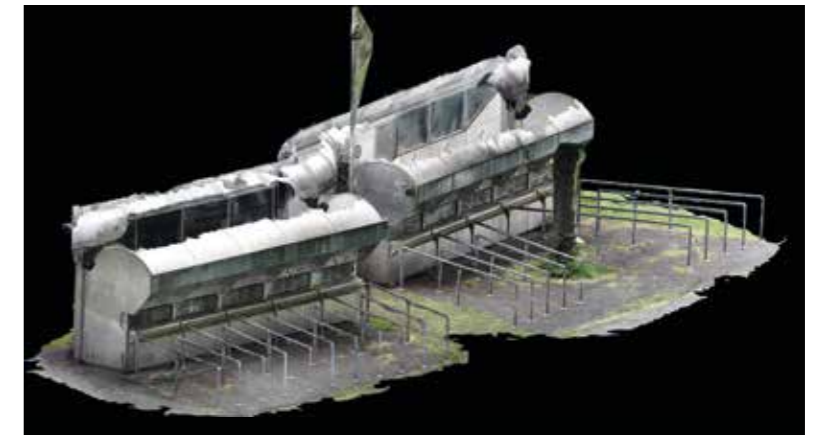
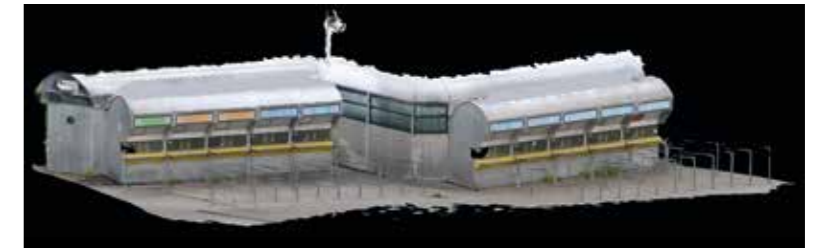

Images: 3D model of the ticket booths
 _NO2 (Brinchi Giusti-Casagrande)
 _SW (Jesse Han, Mu-Yen Lee)
 _NW (Jana Calatrava, Lisa Schröter)
 _NO1 (Pietro Sircana, Lucrezia Rodriguez, Livia Calcagni, Chiara Saccomanno)

Young Talent Awards



Senator Bernhard Borst Prize 2019

Image above: Maximilian Graber, Consolidation of the city – Berlin, Chair of Urban Architecture, with Lukas Walcher

Image left: Jonas Hamberger, An economy of means – Residential transformation in Athens, A house in the urban context of the Karaiskaki rotary, Chair of Urban Design and Housing, in collaboration with Eva Hofmann and Vanessa Salm

1st IGEB International Sustainable Building Design Competition

Silver Medal: “Wor(al)king in the Forest”, Borja Maristany Domínguez, Evgenii Varlygin, Federica Aridon, Florian Kraft, Georg Hyza, Niklas Heese, Margarita Alwalidi

Supervised by the Chair of Building Technology and Climate Responsive Design.

BDB Sponsorship Award 2019

Gebäude: „Bauen in der Zeit“, Laura Dominique Pastior; „Thick brick building - living and working in Hamburg“, Dominic Ahn, Matthew Dueck, Lukas Presteke

Urban development plans: „Wohnutopie“, Maximilian Blume; „Main Street is (almost) alright“, Tobias Johannes Haag, Yonne-Luca Hack

Constructions: „Um die Ecke gedacht: Ein Aussichtsturm aus Stampflehm“, Marion Montiel-Cabrera, Sophie Johanna Ramm

AIV-Schinkel-Competition 2019

Special Prize: Philipp Rothbächer, Jonas Schergun
Shortlisted: Theresa Holl, Elena Rigato
Supervised by the Chair of Urban Architecture

Markt Schwaben macht sich 2019 (Markt Schwaben is getting ready in 2019)

1st Prize: “Schatzkiste”, Elena Englmann, Dennis Vrslynin, Valentin Breitsamer, Alicia-V. Hergardt, Luisa Amann, Christoph Hultsch

2nd Prize: “The Square”, Friedrich Mönninger, Leonie Straub, Mira Kirsch, Valentin Humbeck, Silvia Stitzinger, Nadine Rott

3rd Prize: “Fahrenheit 451”, Elena Spatz, Agi Hidri, Wenshan Cui, Magdalena Schadhauer, Anna Christina Lüßmann, Theresa Zöllner

All supervised by the Associate Professorship of Architectural Design and Timber Construction



Senator Bernhard Borst Prize 2019

Image above: Dominik Thoma, Master’s Thesis, “Putz als zeitgenössisches Gestaltungsmaterial”, Professorship of Architectural Design, Rebuilding and Conservation

Image above right: Nick Förster, “Glyptothek” installation and local politics, Königsplatz Munich, 2019, with Maria Schlüter, ongoing

Image right: Tanja Schmidt, Master’s Thesis, Hans Guck in die Luft – Bavarian Public Observatory”, Chair of Architectural Design and Conception



wa award 2019

Maximilian Blume, Master thesis “Eine Wohnutopie”, supervised by the Chair of Urban Architecture.

Two Universal Design Awards

Prof. Fritz Frenkler, Chair of Industrial Design together with his students
Project: “Haftsache”

Vorarlberg Timber Construction Prize

Category “Temporary Building”: Prof. Hermann Kaufmann, Maren Kohaus, Chair of Architectural Design and Timber Construction, together with Atelier Andrea Gassner for proHolz Austria, proHolz Bayern and Lignum Schweiz
Project “woodpassage”

Hans Döllgast Prize 2019

Marion Montiel Cabrera, Master thesis “Schiffsmuseum Nao Victoria”, supervised by the Chair of Professorship of Architectural Design and Timber Construction;

Philipp Valente, Master Thesis „Bauernhaus Narburg“, supervised by the Chair of Architectural Design and Construction and the Chair of Theory and History of Architecture, Art and Design

BDA-SARP-Award 2019

Maximilian Blume, Master’s thesis
Project: “Eine Wohnutopie”

Renzo Piano World Tour Award

TUM Alumni Lukas Kaufmann

The Plan International Award 2019

Special Projects: Roberta Fonti, Research associate at the Chair of Restoration, Art Technology and Conservation Science, Project: “Architecture in restoration as a sum of geometrical beauties. A novel temporary design for the old main altar of the church of Saint Cajetan in Munich.”

Senator Bernhard Borst Prize 2019

Nick Förster, Maximilian David Graber, Jonas Hamberger, Tanja Schmidt, Dominik Thoma

AFFORD PALACE



ABLE

Architecture as a medium for political discussion

Affordable housing? This type of housing has long been a scarce commodity in major cities such as Munich or London. Nowadays, flat hunting is by no means a problem reserved to low-paid workers, but also concerns average wage earners and families in which both parents work full time. In other words, this includes the middle class, whose prosperity and social satisfaction are considered to guarantee a stable democracy. Affordable housing is in short supply, and accommodation is increasingly becoming a luxury good on an unregulated market. Affordable living space has thus become one of the most important social challenges of our time in major cities and, of course, preoccupies us architects as well. At the moment, many competitions dealing with this topic are being advertised. Our agency, Opposite Office, participated in such a competition for 'Affordable Housing' in London. England, of all places; London, of all cities! The Brexit debate has paralyzed the whole country and overshadows everything. Under these, as it is, fickle conditions, we sought to contribute to the topic of architecture as a medium for political discussion through our design. To what extent can architecture be a provocation? Do you have to consider social housing as homes for 'the poor'? We asked ourselves these questions as we interpreted the task 'Affordable Housing' in London as 'Affordable Palace'.

With its 775 rooms and 79 bathrooms, Buckingham Palace's room supply is not representative of London's rental housing. The rooms are decorated with sparkling chandeliers, sumptuous carpets, marble columns, sculptures and expensive artwork. So why not use this existing structure to tackle the housing shortage and treat Buckingham Palace as social housing?

Reactions provoked by our project show that there is a great deal of explosive power in our architectural image because the social and political implications of the building go together with it and have been thought

With their utopian design, Benedikt Hartl (Chair of Building Construction and Material Science / Opposite Office) and his collaborator Thomas Haseneder attracted international media attention. The Süddeutsche Zeitung ran the headline 'Architect wants to convert Buckingham Palace into social housing' and the AD Magazine asked 'When does architecture become satire?' But the proposal also caused outrage and criticism, among other places in British tabloids.

Benedikt Hartl's agency, Opposite Office, received an appreciation award for the provocative design in an ideas competition on affordable housing in London and has submitted the proposal to the Queen in an open letter.

through. At a time when the definition of national identity is at stake, British tabloids, spoiling for sensation and indignation, gratefully took up the idea and, above all, emphasized the fact that we, who disrespectfully lay hands on a British national treasure, are Germans. In addition to anti-German resentment, with terms such as ‘Merkeltowers’ and ‘Albert Speer 2.0’, it was above all the virulent refugee issue that served to explain the lack of affordable housing: ‘If we didn’t have so many illegal immigrants here, there wouldn’t be a problem’ or ‘No need to do this at all just stop uncontrolled immigration problem solved’. Another Daily Mail reader commented on our addition of floors to Buckingham Palace: ‘50,000 Londoners will any of them be white?’ This heated xenophobic discussion shows that an architectural project can indeed be a political provocation. Other readers, who already imagined our design built, blamed the EU for it and demanded a quick Brexit: ‘So why wasn’t this awarded to a British firm????’, ‘So much for loyalty’, ‘And people want to remain in the EU?’.

Here, the numerous reactions show that an architectural image may convey political ideas and fears. The unusual, seemingly disturbing image of a Buckingham Palace fitted with additional floors was enough to provoke extreme thoughts. On the one hand, royalists and conservatives felt provoked and saw this *lèse-majesté* as an attack on the entire nation and its national identity. People with a right-leaning mindset view the influx of foreigners as the reason behind rising rents. Critics of capitalism and leftist anarchists see in this image an overthrow of the prevailing conditions.

I have to admit that we did not expect opinions to be so extreme. Of course, we did wish to be provocative, but not to create a nationalist uproar and even less to insult the Queen; instead, we sought to contribute to the social policy debate.



Of course, there were also some comments on the Internet and in letters to the editor that recognized the polemical character of the image, and did not blindly believe in a real project whose realisation depended on fire escape staircases, corridors, and static calculations. Many comments anchored our project in a political dimension: ‘This was never meant to be a serious proposal, but a commentary on the ever widening gap between the ultra-rich and the growing poor and homeless population. Also the suggestion to put the glass box on top of the structure, I believe, to be a satirical dig at the many, MANY, similar adaptations of historical buildings that have been absolutely ruined by such “forward thinking” across the world.’ The architectural image (Affordable Palace) makes visible a societal problem (Affordable Housing); thus, it does not become an implementable project, but a polemical projectile within the socio-political discourse.

And who would have thought that, of all people, the British, who like to think that they invented black humor, would so badly deal with architectural provocation and humor? As one reader aptly put it: ‘Who knew that the Brits were so lacking in humour and so (still) in love with their anachronistic monarchy (yes that is you all you butthurdy commenters). Did you not laugh at “Eight dramatic staircases and lift cores would descend through the historic palace so the queen can mingle with her subjectsturnedhousemates in the communal areas.” Ever seen the queen “mingling” with commoners?’

Benedikt Hartl

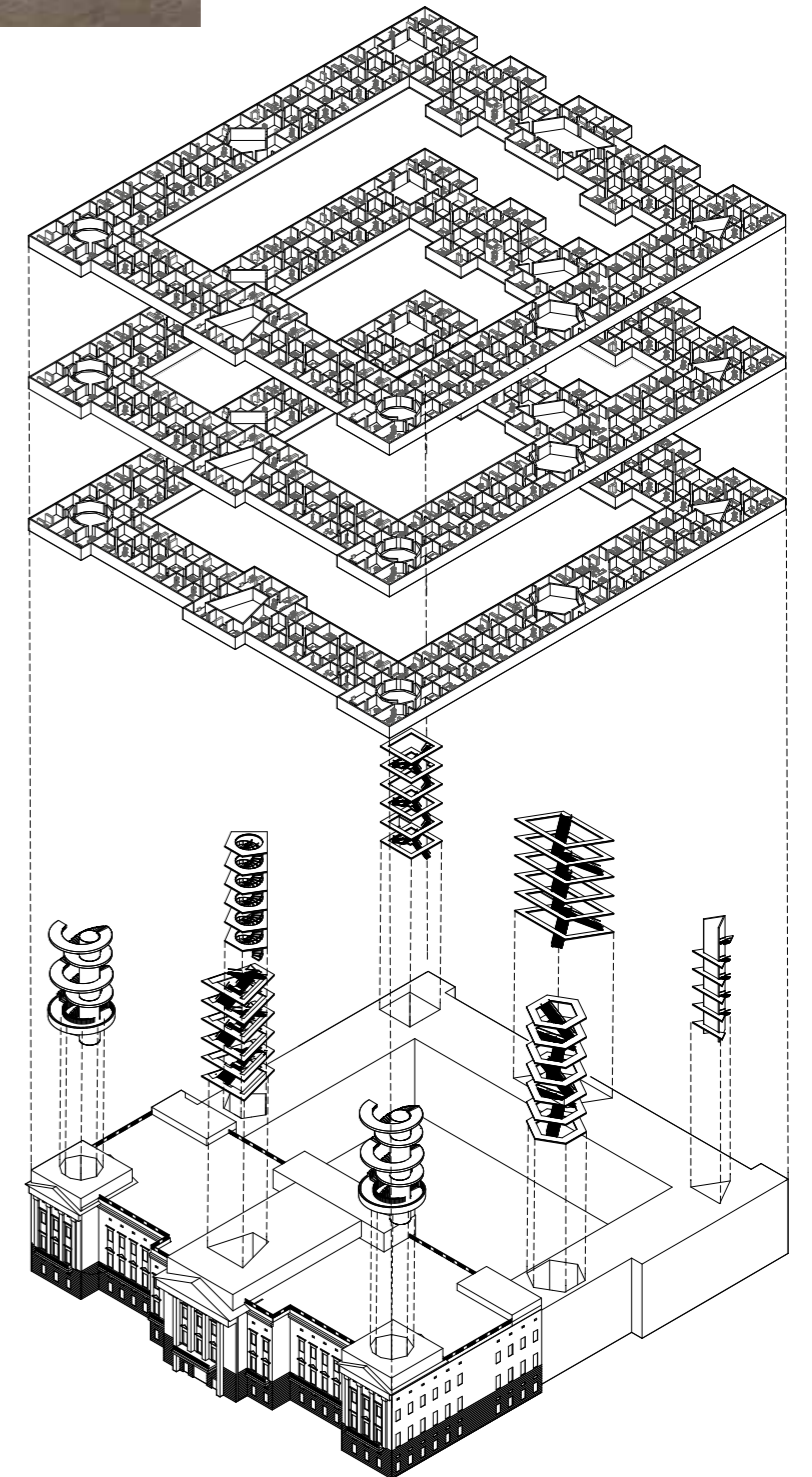

Buzludzha Monument Project

Conservation and management plan for one of the “7 Most Endangered” heritage sites in Europe

PROJECT INFORMATION SUMMER

Survey and analysis of one of the most endangered heritage sites in Europe

Chair of Conservation-Restoration, Art Technology and Conservation Science
Prof. Dr. Thomas Danzl, Dr. Roberta Fonti, Nadia Thalgut

Assistant Professorship for Recent Building Heritage Conservation
Prof. Dr. Andreas Putz, Meltem Çavdar

Partner Institution

Bern University of the Arts, Conservation and Restoration, Jonas Roters

Dresden Academy of Fine Arts Conservation and Restoration, Carola Mówald

Project partner

ICOMOS Germany, Jörg Haspel

Buzludzha Project Foundation, Dora Ivanova

Funding

The Getty Foundation, “Keeping It Modern” Initiative

Students

Jonatan Anders, Mara Emprechtinger, Annemarie Grimm, Simon Leitner, Dorothee Ohlhof, Lisa Schröter, Anna Schuh, Carina Thomas

The Getty Foundation has awarded a \$185,000 grant for the conservation of the Buzludzha Monument as part of its 2019 ‘Keeping It Modern’ Initiative. Prof. Thomas Danzl, holder of the Chair of Conservation-Restoration, Art Technology and Conservation Science, and Dora Ivanova, founder of the “Buzludzha Project” Foundation, are the organizers of the field studies, which are part of a large initiative on the iconic and controversial artifact of Bulgaria’s socialist era. Together with Andreas Putz, Professor for Recent Building Heritage, they offered a kick-off summer school.

The Getty Grant will fund the creation of a Conservation and Management Plan for the Buzludzha Monument, beginning with a full evaluation of the building’s condition. It will explore the future (re)use of the monument, and aims to establish a viable business model for operating Buzludzha as a reinvigorated heritage site. This project will conclude with the release of a public report in September 2020, forming a basis for further decision-making.

The project will be undertaken by a multidisciplinary team of Bulgarian and international experts. The project partners are the German and Bulgarian committees of ICOMOS (International Council on Monuments and Sites); the Technical University of Munich; the University of Architecture, Civil Engineering and Geodesy in Sofia as well as the Buzludzha Project Foundation, a Bulgarian organization which has been campaigning since 2015 for the monument’s preservation. The original architect of the Buzludzha Monument, Georgi Stoilov, will also have a key role in the project.

The Buzludzha Monument is a unique piece of 20th century architecture, art and engineering. Located on a mountain peak in central Bulgaria, this special structure was completed in 1981 to celebrate the history of socialism. It was used for only eight years – until the dissolution of the socialist regime in Bulgaria in 1989. Today the glamour has turned into decay and the building is highly endangered, but still attracts attention due to its dramatic history, gravity-defying architecture and 1000m² of extraordinary, colorful mosaics. Its saucer-shaped body, with a 60m free-spanning roof and 20m overhangs, symbolizes a wreath commemorating the historical events which happened there. In February 2018, the monument was recognized by the heritage organization Europa Nostra as one of the “7 Most Endangered” heritage sites in Europe.



Image left: Drone view of the Monument. © Mariyan Tashev
Image below: Students and docents from TUM, © Nadia Thalgut
Image below: Side work, © Andreas Putz

During the summer school in September 2019 the current condition of the building was documented and the reasons for the decay were analyzed. Architecture and restoration students worked together in groups to develop a basis documentation. Exchange between experts and students from these two fields contributed a better understanding of the construction and materiality of the complex structure. This documentation will contribute for further planning and discussion of the monument’s future.

Meltem Cavdar



Project: COMMUNITREE
 Summer Semester 2019
 Chair of Architectural Design and Participation, Prof. Francis Kéré

Entitled 'Communitree', the studio's task was to design an independent sustainable structure that should serve the community both as a provider of energy and as a gathering space. Students were given the choice of context in sub-Saharan Africa, taking into account their personal interests. Research about each site preceded the design. Thirty students took part in the Bachelor's course of the Chair of Architectural Design and Participation.

Our projects develop a sensibility to contextual factors from which invention can arise. Conceptual thinking is combined with a hands-on approach to site-specific solutions that acknowledges the importance of local resources and the needs of the community. A diversity of projects was developed from the brief. For instance, the 'Lifeline' Project located on the Niger River, developed a floating structure to produce clean water for the villages located by the river. This uses modular platforms filled with biosand filters. In another approach, the project 'Bridge for Resilience' developed an open workshop with a space for residents to process plastic, recycle it and transform it into new resilient materials. Experiments in a 1:1 scale complemented the design research process.



Image above: Bridge for Resilience. Accra, Ghana. Open workshop for residents to process plastic and recycle it. Students: Maria-Dolores Heinrich, Nora Guzu (BA)
 Below: Lifeline. Niger River. Floating structures with biosand filters providing drinking water. Students: Egzon Musa, Prayudi Sudiarto, Andreas Winter (BA)



Image above: New Leaves. Blikkiesdorp, South Africa. Neighborhood pavilions with optional functions: educational library, showers or community kitchen. Students: Anna Kamm, Karolina Hein (BA)
 Below: Water Village. Dikwa, Nigeria. Water towers providing water for the community. Students: Ildiko Schepp, Franziska Mader, Verena Vogel (BA)



The Architecture Machine

The Role of Computers in Architecture

PROJECT INFORMATION

Exhibition

The Architecture Machine. The Role of Computers in Architecture

Architekturmuseum der TUM

July 16 – October 25, 2020

Curated by Teresa Fankhänel

The exhibition is supported by PIN. Freunde der Pinakothek der Moderne.

Publication

For the preparation of the book and exhibition, the research project "Pixels, Vektors and Algorithms. The Digital Revolution in Architecture" is supported by the Gerda Henkel Foundation.

Conference

On October 11, 2019, a conference was held at Vorhoelzer Forum. For details about the program, see: www.architekturmuseum.de

Easy to Own, Easy to Use?

The Apple II was the first affordable minicomputer on the market. It was a finished appliance that came with a keyboard, a power supply and 4K memory right out of the box. With the introduction of the Macintosh it added even more convenience: a user interface and a mouse. In 1977, the year of the Apple II's release, the retail price of \$1,298 was a bargain. In some of the earliest commercials shot by Apple, Dick Cavett, the American talk show host, tagged it 'the original personal computer: easy to own, easy to use.' The Apple II was a bestseller that turned Steve Jobs and Stephen Wozniak into multimillionaires. It also opened up computing to all those who did not have advanced degrees in computer science to write, to design and to draw – with an instant visual output on a screen. The Apple II rang in a new era of personal computing. The sleep-deprived mornings after all-nighters on mainframe computers, which were routine in the handful of architecture schools fortunate enough to have access to one, were numbered. Architects started buying computers.

The first PCs were installed at TUM's School of Architecture in the mid-1990s, a few years after the Apple II was discontinued. Photographs of the first computer lab show a hodgepodge of diverse proprietary pieces of hardware, with NEC Multisync screens, IBM towers, Microsoft mice and Summasketch III drawing boards among them. The first to make use of the new equipment at the Department of Architecture were visiting professors Manfred Wolff-Plotteg from Austria (1994-1995) and Richard Junge (1995-2009), who went on to become the first professor for CAAD (Computer Aided Architectural Design) at TUM. Less interested in experiments than in realistic applications, the latter had been an early user of German-made architectural software and was one of the first architects to purchase RIBCON in the early 1980s. Before joining the university, Junge had been a partner at Schmidt-Schickentanz und Partner, where he was responsible for the new Lufthansa Catering Building at Munich airport. The office had first installed a computer to do the cost calculation for this scheme. At TUM, he began teaching classes to get architecture students acquainted with the new tool but quickly moved on to focus on instructing them in CAD software, such as ALLPLAN and AutoCAD. Students were required to recreate existing buildings to familiarize themselves with the interface and learn the ins and outs of the software. Designing with the computer was not yet on the agenda.

The Architecture Machine

Digital architecture predates the computer. From the calculation of the proportions of parts to the whole in ancient temples, to Renaissance and Classicist buildings all the way to Antoni Gaudí and Frei Otto, computational methods are omnipresent in the history of architecture. But after World War II, with the advent of the first interactive cathode ray monitors and light pens, the machine slowly took over more tasks than anyone could have imagined. First, it became a tool for book-keeping and structural calculations. Then, it began to automate drawings and facilitate file-to-factory processes. It helped create the first digitally modeled films and renderings, and turned architectural design loose by allowing previously impossible shapes to be conceived. Today, following the introduction of the Web 2.0 in 2004, the computer has become a platform for architects, engineers, and a general audience enabling them to create, to experience and to play in built as well as virtual realities.

One of the pioneers of the movement, Nicholas Negroponte, saw it all coming. The cofounder and public face of the Architecture Machine Group at MIT's Department of Architecture in Cambridge, Massachusetts, had envisioned computers as more than an assembly of switches and circuits to facilitate tedious calculating tasks. Instead, the computer should have human attributes. It should be able to listen, to talk and even to worry about design problems. Since the 1960s, the Architecture Machine, a large IBM mainframe computer on MIT's campus, underwent a series of challenges that were supposed to evolve it toward an ideal: the computer as the designer's equal partner, an almost intimately personal and intelligent device. From learning to recognize hand sketches to understanding the human voice, obeying orders, and executing basic design rules, the machine mastered many of the experiments but failed at the most important one: it could not learn. Almost sixty years later, the dream of an intelligent machine that can create architecture independently is still awaiting fulfillment. Computers have taken over large areas of design nevertheless. It is high time to give them the recognition they deserve.

Some Machines Will Attend. We Hope that You Will Play with Them¹

In 2018, the Architekturmuseum der TUM initiated a research project that is starting to unravel parts of this history of the computer's role in architecture. Funded by the Gerda Henkel Stiftung, we are working toward an overview of architectural software and input devices created since the days of the first Architecture Machine. We are studying the impact that computers have had on everyday practices in architectural offices as well as on the wider image of architecture as it is presented to those commissioning, judging and appreciating it. In preparation for the project, the Architekturmuseum took over Richard Junge's slide collection of the Chair of Architectural Informatics, which includes screenshots



Image: Computer lab at TUM in the mid-1990s. © Architekturmuseum TUM

of software interfaces, student projects, and references. These analogue images are currently being returned to a digital state.

With decades of development behind us, we have chosen forty exemplary projects to illustrate major milestones. They are loosely associated with one of four main themes that constitute the basis of our exploration: drawing machines, computer-aided design, story-telling, and interactive platforms. One of the outputs will be a publication featuring all case studies as well as new research by eight scholars from across the globe. As part of the groundwork for the book, we invited several of them to Munich for a workshop on October 11, 2019, culminating in a public session and featuring an additional six researchers, asked to present both new historical work as well as current practices. The main output of this project will be an exhibition at the Architekturmuseum der TUM, running from July 16 until October 25, 2020 under the title 'The Architecture Machine. The Role of Computers in Architecture.' It will present original material from the 1960s until today, much of which has rarely been seen in public. As an homage to its namesake, the original Architecture Machine, we will install several reconstructed versions of early architectural software, such as Ivan Sutherland's first architectural drawing program, Sketchpad, as well as newly developed interactive programs that will allow visitors to do exactly what the pioneers had envisioned: to play with the machines.

Teresa Fankhänel

¹: Letter by Nicholas Negroponte and Leon Groisser, May 15, 1969, 4.704 Computer Aided Urban Design, Groisser/Negroponte, AC-0400, box 6, Department of Distinctive Collections, MIT Libraries, Cambridge, Massachusetts

GERDA HENKEL STIFTUNG

PIN. FREUNDE DER
PINAKOTHEK DER MODERNE E.V.



Final Critique

Picture: Master project “Conceptual design for a secondary school in Munich based on Scandinavian models”, Summer Term 2019, Room 3365. The project had been supervised by Sto Foundation Visiting professor Mikala Holme Samsoe at the Chair of Spatial Art and Light Design.

Photo: Tassilo Letzel © TUM Department of Architecture

Interview

Prof. Dr.-Ing. Eike Schling in conversation with Hanne Rung

Eike Schling is an independent architect and professor in Architectural Structures at the University of Hong Kong. He teaches parametric methods, architectural geometry and structural behavior, with a view to enabling construction-aware design. His research investigates gridshells composed of repetitive elements, and deals both with geometric parameters and constructive criteria.

In 2018, he completed his doctorate, "Repetitive Structures", with distinction at the Chair of Structural Design at the Technical University in Munich, and has since lectured at the ETH in Zurich, the Ecole des Ponts Paris, TU Vienna, and KAUST.

Born and raised in Munich, during your architectural studies at the TUM you decided to go abroad. Looking back on your career path, how important was this experience for you?

My international experience has greatly influenced everything I have done to this day. After the intermediate examination in 2004, I needed a break and went to Shanghai for twelve months to work in a Chinese architecture office. There, I saw how fast architecture can move forward and the responsibility that we architects carry in this regard. During my undergraduate studies, I also spent a year studying at McGill University in Montreal, where I learned about parametric modeling. This decisively contributed to the success of my diploma at the TUM. After a year's work in Munich, it became clear to me that I wished to go away again, to London or some other large city where I could apply my computer skills. These were not in demand in Munich offices.

This means that you picked up the basics for your later specialist field abroad?

Yes, that's right. In Montreal there was this crazy, very artistic professor of mathematics who mentioned the topic of "parametrics". At that time, it was still in its infancy. As a result, I flew to Indianapolis with a classmate to attend a Generative Components (GC) workshop, where I also met key exponents. The software was a relief for me. All of a sudden, architectural design was no longer static, but flexible. It no longer consisted of chain dimensioning but of dependencies. Back in Munich, the thesis by David Kosdruy and myself was the first parametric architecture project at the TUM. That was in early 2008. We were able to present it at the Smart Geometry Conference, and a year later were both employed as computational designers in a London office.

How did you go about transferring your knowledge into teaching?

When I started at the Chair of Structural Design at the TUM in 2012, I wished to convey parametric design to the students. But their training in 3D modeling was very uneven and I was not meant to offer a CAD course. In the end, my tactic was to focus on the parametric way of thinking, the software then came all by itself.

We designed modular structures similar to honeycomb. Students had to build a single module and think about the dependencies that determine its shape, and how these would emerge if many identical modules were strung together. In other words, how does the single module influence the overall shape? The project was called Experimental Structures and examined a research



Final presentation in the enrollment hall, photograph: Tassilo Letzel
© TUM Department of Architecture

question that had been preoccupying me for a long time, namely whether it's possible to simplify complex supporting structures by building them from the same elements.

In your dissertation, "Repetitive Structures – Design and construction of curved support structures with repetitive parameters", you explored the topic in even greater depth. Where are breaks and opportunities to be found for future construction?

At some point I realized, that it was not repetitive modules I was looking for, but the geometric parameters that control their geometry. If one proceeds at this much more fundamental level of reflection, then dependencies suddenly become clearer and the fundamental laws of "repetitive structures" can be described. Of course, this step forward did not happen overnight. I had many discussions with my supervisor, Rainer Barthel, and the mathematician, Helmut Pottmann, until the penny dropped.

After that, I prepared a table of the determining parameters of a grid structure and tested their behaviors. One of the most important findings of the work is that definitely not all parameters should be the same. If everything is built from identical parts, the design spectrum is much too constrained. You end up with only flat or cylindrical designs.

It is much more exciting to understand the individual parameters and to know what influence they will have on the design and shape. Then the architect can very deliberately decide on the degree of complexity that he is prepared to design to, which tool he prefers and the costs he is willing to accept.

At the moment, your research focus is on gridshells, that is to say double-curved structures. Actually, you have already realized the first projects! Is it conceivable that new façade architectures could also be developed?

Of course, I first specialized in supporting structures because it's my research field. And that's also the reason why I was mainly concerned with grids, and nodal points, and less with façades. However, a façade can also be described in the same way, with parameters, and can also be simplified in the same way. Many publications already deal with the geometric optimization of façades and I can also see an exciting overlap for my future research.

Is thinking in terms of modules and parameters something that could also be applied to urban planning?

That would certainly be possible, but the question is: What would be the sense of it? As regards supporting structures, the advantage lies in a straightforward production and also in the aesthetics that result from the systematic design. This systematics might also have some potential for urban design by allowing certain sustainable or social characteristics. But it would be feeble to apply it solely for its chic look and nothing else.

With your appointment at the University of Hong Kong (HKU) as a Tenure Track Assistant Professor, a new chapter of your life is going to begin abroad. What are your expectations, what challenges will you meet there?

During my inaugural lecture at the HKU, I presented our teaching and research. And the Department of Architecture was enthusiastic about our system and its technical, innovative results. The greatest challenge will be to keep up the momentum and successfully continue my research and teaching in this new environment.

At the same time, I can well imagine that their expectations and requirements are completely different from those in Munich. The HKU is one of the best universities in Asia and worldwide. Out of 30 applicants, only one student is admitted to study there. 80% of the students come from Hong Kong or China, and have enjoyed a completely different schooling from the one I'm familiar



Image above: First professional experience at Haipo Architects in Shanghai 2006: DBS Tower in Lujiazui, Shanghai.

Image below: Diploma thesis completed in 2008 at the Chair of Structural Design, Prof. Rainer Barthel, TUM.

Image right: Working as a Computational Designer for PLP Architecture in London 2011. Nova Victoria, Mixed Use Development, Victoria Station, London

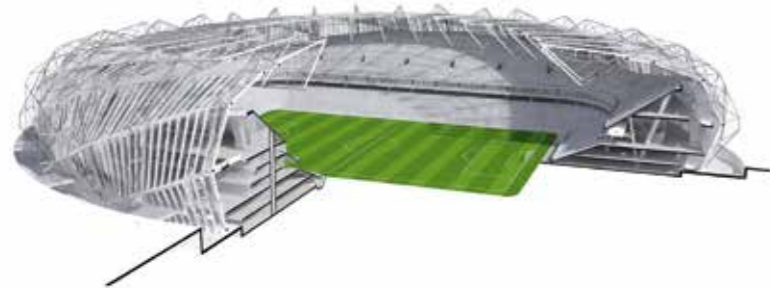

with. I'll surely have to learn to question my habits. The research isn't going to be easy either. I've learned that successful research only works as a team. And of course, I have been spoiled by the Chair of Structural Design or the metal construction company Brandl. Even though I will constantly keep in touch with Munich, I will first of all have to build up local partners at the HKU.

This means that contentwise you will remain connected to the TUM?

The connection will continue for certain, if only because my research topic is already flowing into the next dissertation. Jonas Schikore, a colleague, is applying our parametric approach to elastic grid mechanisms. This opens up a whole world of possibilities. I'm very involved in that and I want it to stay that way. Besides, we are planning a student exchange between the architects of the TUM and HKU. I think this would be a gain for both institutions. Of course, the University of Hong Kong is interested in building up such international contacts.



Thus basically the wheel will come full circle. You discovered the parametric structures for yourself while abroad, then came back to explore the topic in greater depth, and now are taking this knowledge with you to share it further.

And all these experiences abroad are now helping me in my new job. In North America, I experienced a very different teaching approach: There, the boundaries between art and architecture are fluid, and far more emphasis is placed on literature and method during the design process. Things are similar at the HKU and it will be exciting to introduce my technical subject matter there.

Working in international firms in Shanghai, Montreal and London, has taught me how different other cultures approach architectural design and planning in terms of speed and creativity, but also, serenity. I hope that will help me to cope in my new working environment. Moreover, practical experience is very important in order to practice teaching and research with both feet on the ground.

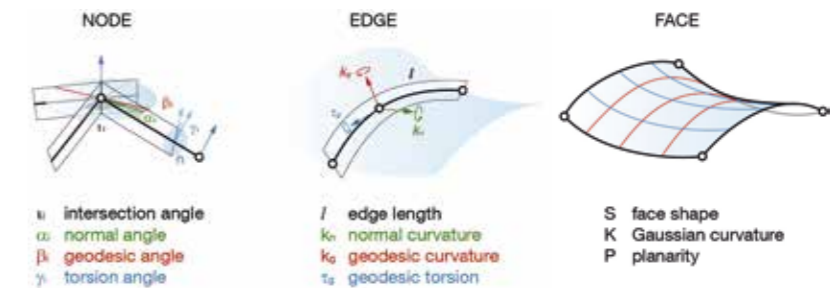
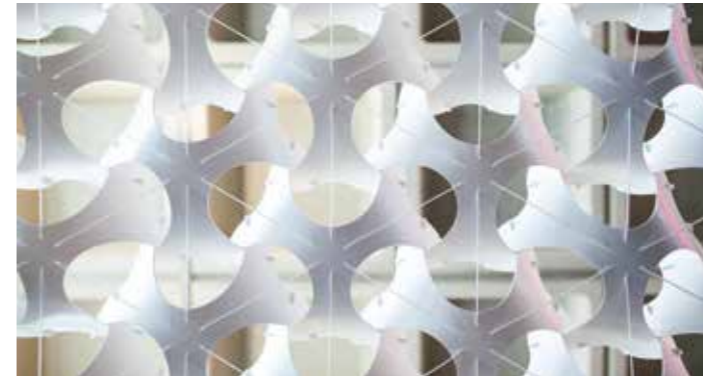

Image above: Modular Structures. Master Design Studio 2014 at the Chair of Structural Design: Hexagonal Bending by Quirin Mühlbauer.

Image right: "Repetitive Structures", dissertation in 2018. A list of ten geometric parameters can be used to define the repetition in double-curved gridshells.

Image right: The first asymptotic gridshell was completed in 2017 at the central campus of the TUM.

Image below: The first commercial gridshell using asymptotic curves will be completed in 2019. The canopy for the Intergroup Hotel in Ingolstadt.



“[...] how different other cultures approach architectural design [...] in terms of speed and creativity, but also, serenity.”

Eike Schling

New Professor

Dr. Kathrin Dörfler

Tenure Track Assistant Professor of Digital Manufacturing

As of June 1, 2019, Dr.-Ing. Kathrin Dörfler, post-doc for Digital Fabrication at the ETH Zurich, was appointed Tenure Track Assistant Professor for Digital Manufacturing at the Department of Architecture and the Department of Civil, Geo and Environmental Engineering at the TUM. Kathrin Dörfler studied architecture at the TU Graz and TU Vienna, as well as digital art at the University of Applied Arts Vienna. She worked at various architectural firms, founded the architecture collective dorfundrust, and carried out teaching and research at the TU Vienna and the ETH Zurich. An 'Augmented Fabrication Lab' will be established at the TUM under her leadership. The new research group will explore the interface between architecture, robotics and human-computer interaction. Of particular interest is the use of augmented reality technologies to explore the potential of seamless communication and information exchange between humans and machines in digitalized manufacturing processes.

Kathrin Dörfler, © Béatrice Devènes



Image above: Mobile part-based AM: Fabrication scenario of a stay-in-place formwork using an arm-based mobile robot platform on site.

Image right above: The residential unit DFAB HOUSE of the Empa NEST building in Dübendorf, Switzerland, developed by researchers of ETH, displays five different innovation objects that aim to advance digital fabrication techniques in building construction. Gramazio Kohler Research 2018.

Image right: The In situ Fabricator (IF) and Mesh Mould: the mobile construction robot IF is fabricating the last layers of the steel rebar mesh for the bespoke reinforced concrete wall on the DFAB HOUSE construction site, situated at the NEST building of Empa, Dübendorf, Switzerland. Gramazio Kohler Research 2017.



Guest Professors

Bill Addis

Chair of Structural Design | Prof. Dr. Rainer Barthel

As part of the August-Wilhelm Scheer Visiting Professorship Program, London engineer Bill Addis once again worked at the Chair of Structural Design of the Department of Architecture. The deepening of international cooperation during the summer semester of 2019 was intended to develop a joint research project in the field of the history of structural engineering and construction. For almost forty years, Bill Addis has been dealing with the history of structural engineering and building materials. He is the author of over 100 publications on structural engineering history and design (practice), the curator of several exhibitions and a member of the editorial board of Engineering History and Heritage, a journal of the Institution of Civil Engineers in London. He has taught at the universities of Cambridge, Bath, Reading, Rome, Zurich, San Sebastian, Innsbruck and Brussels. During the summer semester of 2018, Addis already reported on his experiences and research results in lectures, workshops and public talks at the TUM Department of Architecture. This year's goal was to develop a joint research project in collaboration with the Chair of Structural Design, Prof. Rainer Barthel. Knowledge gained from the history of the design and construction of wide-span lightweight structures should be harnessed for maintenance and repair. In this respect, the focus was on post-WWII buildings. In particular, membrane constructions, and gridshells made of wood and steel occupied center stage.

Olajumoke Adenowo

Chair of Theory and History of Architecture, Art and Design | Prof. Dr. Dietrich Erben

Olajumoke Adenowo, the renowned Nigerian architect, presented a lecture and a workshop during the summer semester as part of her visiting professorship at the Chair of Theory and History of Architecture, Art and Design. Olajumoke Adenowo is a prominent architect, author and radio presenter from Lagos, Nigeria. She was praised by CNN as 'Africa's Starchitect'. She is the founder of 'AD Consulting', an internationally acclaimed architectural firm, and 'Awesome Treasures Foundation', an intercontinental phil-

Olajumoke Adenowo, © Emmanuel Oyeleke



anthropic foundation. The latter's mission is to nurture a total of 1,000 managers in their work with women and young people by 2030. Adenowo has completed more than seventy buildings to date. While at the TUM, Professor Adenowo gave a lecture entitled 'Democracy Reflected in Form Space and Order: Learning from West Africa's Ancient Empires' as part of the lecture series: 'The Architecture of Democracy: Inspirations from the Global South'. Furthermore, she held the workshop 'Architecture and Space: On Form and Function in Nigeria' in the Haus der Kunst.

Philipp Auer

Chair of Institute of Energy Efficient and Sustainable Design and Building | Prof. Dr. Werner Lang

In the past summer term, Philipp Auer supervised the Master's design 'Chiamaira – an architectural monster' as a Visiting Professor at the Chair of Energy Efficient and Sustainable Design and Building, headed by Prof. Werner Lang. Philipp Auer, who has been an executive partner of the renowned architectural firm Auer Weber since 2017, was born in Stuttgart in 1967; he studied at the TU Stuttgart and the TH Darmstadt. From 1995 to 1997, he worked at David Chipperfield Architects in London, and since 1997 at Auer Weber in Munich. The office, founded in 1980 by Prof. Fritz Auer and Prof. Carlo Weber, is based in Stuttgart and Munich, and currently employs around 140 people. For almost twenty years, they have been implementing international projects, among other countries in Chile, France and China. For Philipp Auer, the guiding principle of all projects is to develop the architectural form on the basis of the task at hand and local conditions in a distinctive, conclusive and comprehensible manner. Today, Auer Weber is one of the largest architectural firms in Germany; it stands out through its successful participation in numerous national and international competitions.

Dr. Matthias Castorph
Professorship of Urban Design |
Prof. Dr. Benedikt Boucsein

Matthias Castorph, architect and urban planner, also visited the TUM Department of Architecture during the summer semester. He presented the Master's project 'blind spot' at the Professorship of Urban Design. After completing his diploma with Prof. Uwe Kiessler at the TU Munich, he joined Andreas Hild as a research associate at the University of Kaiserslautern, where he has been teaching at the Department of Urban Architecture and Design since 2008 as an adjunct professor. In addition, Castorph has already been a visiting lecturer, among others at the Academy of Architecture (ABM) and the ETH Zurich. Since 2012, he has been a managing partner of Goetz Castorph Architekten und Stadtplaner GmbH. Last year, Castorph and Dr. Julian Müller founded the 'Institute for General Architecture'.

Kasper Guldager Jensen
Chair of Building Technology and Climate
Responsive Design | Prof. Thomas Auer

A senior partner at the architectural firm 3XN and a director of the innovative company GXN, Kasper Guldager Jensen was a lecturer during the summer semester of 2019 within the framework of the Sto Foundation Visiting Professorship at the Department of Architecture of the Technical University of Munich. The Danish architect supervised a Master's project on microenvironments and adaptive, sustainable office space at the Chair of Prof. Thomas Auer. Kasper Guldager Jensen holds Master's degrees in architecture from the Aarhus School of Architecture and the Southern California Institute of Architecture. Both in practi-

cal terms and in terms of research theory, his emphasis lies on ecological-sustainable design, digital processes, environment-friendly technologies and new materials. In the space of a few years, Jensen has developed into an international pioneer in the design of forward-looking architecture. Through GXN, he wishes to apply innovative knowledge and technologies to found a new building culture that will positively influence the world we live in – both in architectural and ecological terms. As part of his work as Sto Foundation Guest Professor at the TUM, Jensen managed the Master's project 'The Office' at the Chair of Building Technology and Climate Responsive Design. This project was meant to bring together TUM students with architects from 3XN and researchers from GXN Innovation to discuss the potential of fully adaptable offices that better fulfil human needs through appropriate microenvironments.

Elias Knubben
Chair of Industrial Design | Prof. Fritz Frenkler

During the summer semester of 2019, the Department of Industrial Design proposed a Master's project under the supervision of Guest Professor Elias Knubben, who is the Deputy Chairman of Festo and Head of its Corporate Research and Innovation Department. The Festo Group specializes in automation technology and bionics; it operates on more than 250 sites worldwide. Knubben pursued his studies in industrial design at the Academy of Fine Arts in Stuttgart before completing a PhD at the University of Stuttgart from 2008 to 2014. He has worked for Festo since 2005 and was the Associate Professor of Product Design at OsloMet – Storbymet in 2018–2019. During the summer semester, he managed the Master's project '...what if rooms knew about our dreams?' at the Department of Industrial Design headed by Prof. Frenkler. The topic of the project was the elaboration of

ideas concerning current standards of home automation. By equipping buildings with sensors, as well as recording and consolidating all user data generated by mobile devices, it will be possible in future to match technical solutions with the needs and behaviors of users far more extensively. Large amounts of data and artificial intelligence are leading to comprehensive knowledge about the user and ensure a high probability of successful predictions. This technical possibility, with all the technical risks and ethical challenges attached, also opens up huge opportunities for energy-efficient and comfortable living for people with little time, or with physical or mental disabilities.

Mikala Holme Samsøe
Chair of Spatial Arts and Lighting Design |
Prof. Hannelore Deubzer

During the summer semester of 2019, the Danish architect was once again a lecturer within the framework of the Sto Foundation Visiting Professorship at the Department of Architecture of the Technical University of Munich (TUM). Samsøe proposed a conceptual design project to Master's students, thus providing insights into Scandinavian architectural practice. Mikala Holme Samsøe studied architecture at the Royal Academy of Arts in Copenhagen and, in parallel to her work, completed an Executive Master's program at Copenhagen Business School. As is usual in Denmark, Samsøe was employed in various positions with the construction industry. She still makes active use of these experiences when it comes to understanding various tasks during the planning and construction phases. At the forefront of her career stands architectural quality as a strategic tool and, even, as a necessary component of the sustainable development of our society. Samsøe is a co-founder of the young, successful and competition-driven Studio Force4 in Copenhagen, which made a name for itself through sustainable and experimental housing construction. She then worked for the Danish Ministry of Science, with an emphasis on educational architecture and campus research. Until 2016, she led the international office Henning Larsen Architects in Munich as a member of its executive board. In 2017, Samsøe founded the office SAMSØE og, out of the desire to actively promote the transition from an expansive to a reductional society. The office combines strategy and architecture; it works with both private and public clients during the first phases of planning and of construction projects, its aim being to do more with less. As part of her work at the TUM, Samsøe managed the Master's project 'Conceptual design of a high school in Munich based on the Scandinavian model' during the winter semester 2018/19 at the Chair of Spatial Arts and Lighting Design. Questions such as 'How can architecture promote learning processes?' and 'How do we

communicate and transmit architectural ideas?' were at the forefront, as well as engaging with the material, the contextual analysis of the environment and, also, aesthetic and sustainable decision-making processes.



Tanja C. Vollmer, © Marcel Schwickerath, Werde Magazin

Dr. rer. nat. Tanja C. Vollmer
Chair of Spatial Arts and Lighting Design |
Prof. Hannelore Deubzer

Expert biologist and psychologist Tanja C. Vollmer held the new August-Wilhelm Scheer Visiting Professorship 'Architectural Psychology and Health Care' at the TUM during the summer semester. She conducted a practice-oriented and cooperative research project at the Department of Architecture. Vollmer studied psychology and biology at the Georg August University in Göttingen, where she completed her doctorate in 1997. In 2001, she was certified as a communication psychotherapist. In 2009, she became the director of the Institute for Applied Psychology in Architecture and Health in Rotterdam. There, she developed the online consulting platform 'Psycho-Oncology Online' together with German colleagues. This digital network laid an important foundation stone for e-health psycho-oncology in Germany. Vollmer is also one of the two managing directors of the German-Dutch office Kopvol architecture & psychology, which connects the two disciplines. Dr. Vollmer received international recognition for her pioneering work in the field of integrative psychology, which she began as a research associate at Harvard Medical School, and continues to this day as a lecturer at the Academy of Fine Arts in Munich and the Delft Technical University, among others. Vollmer practices a research-oriented and practice-based architectural psychology linking up the human sciences with the technical and design sciences. Her methodology enables students and young scientists to incorporate psychological knowledge into the design and analysis of rooms and buildings. To this end, she uses findings from the fields of neuropsychology, and perceptual, personality, and health psychology, as well as validated methods for the analysis of users, stress and needs.



Sportarena im Münchner Olympiapark, © 3XN und MIR

Project: Studiolo

Chair of Architectural Design and Conception, Prof. Uta Graff

For the duration of the full first year cycle of their studies, students of the field of architecture and landscape architecture maintain together the introductory courses of 'Grundlagen der Gestaltung' and 'Grundlagen der Darstellung' as well as the Grand Tour as a one week fieldtrip to northern Italy – this time the city of Perugia. The sketching, experience and exploration of Perugia was embedded into the context of a consecutive assignment to design a Studiolo, implemented into the city fabric. During the excursion, the students created their individual plan material with sketches and drawings in situ as basis for their further investigation and design project in Munich.

Within the dense urban fabric of Perugia, a Studiolo is to be designed. In the context of the city, studios can serve different purposes and have accordingly a different architectural appearance. The Studiolo is, in any case, a place for a specific use to be defined in the context of the task and whose specific minimal need for space and equipment must be clarified. In this sense, the Studio is to a certain extent independent of the spatial and temporal parameters of its surroundings. But nevertheless it is impossible to imagine and create it without attention to the context into which it is implemented - regarding the structure and materiality of the city or the light and colourfulness of the landscape.

Review #2 | 19

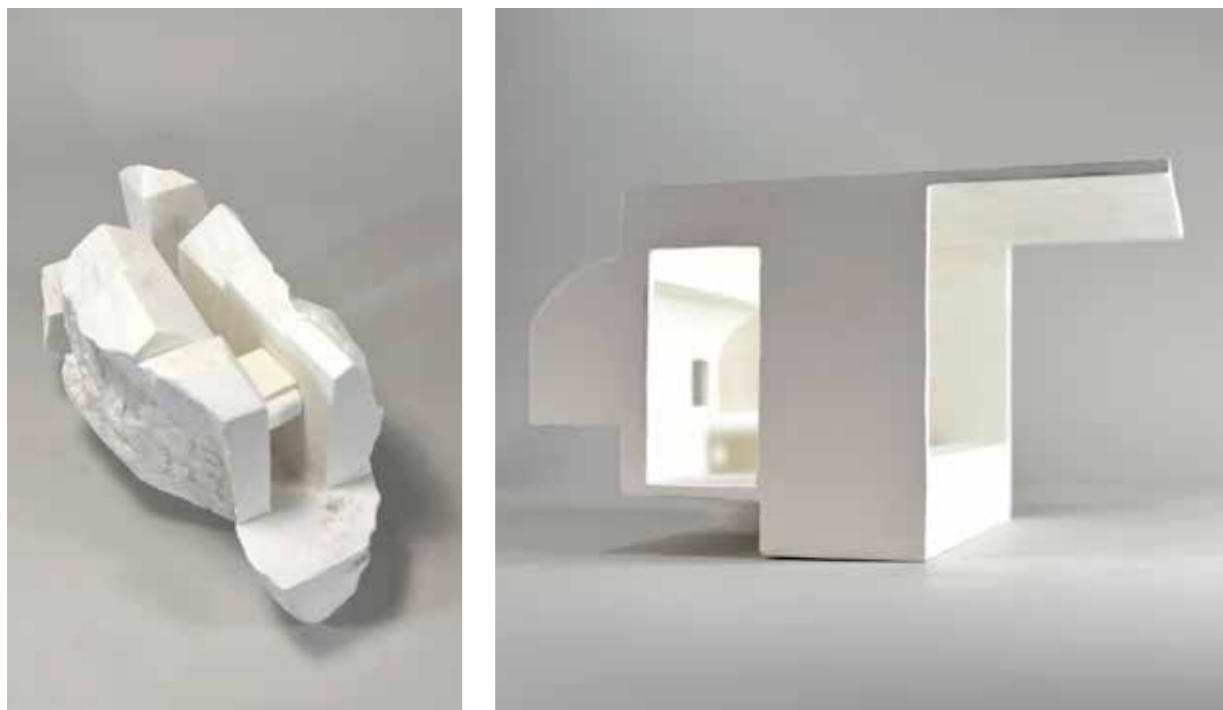

„As the smallest habitual unit, the spatial cell is a materialized form of the individual sphere in two respects. First, it can be regarded as a form of the most intense spatial concentration within which the human individual fully controls his or her environment, equipping it with only the most necessary objects, and keeping everything he needs within reach. The immediate correspondences between spatial requirements and spatial delimitations makes the envelope a matrix within which the free spatial developments of activities can leave their traces as imprint and self-expression without other influences“ 1)

1) Alban Janson, Florian Tigges: Cell, in: Fundamental Concepts of Architecture. The Vocabulary of Spatial Situations, Basel, 2014, p. 46 f.



Images
top left: Silvia Stitzinger, Nadine Rott
bottom left: Anna-Maria Bolok, Leonard Khanmorandi

top right: Johannes Bode, Maximilian Fehr
bottom right: Valentin Breitsamer, Lewin Schmid

BIMwood research project

Modern timber construction and the progressive adoption of Building Information Modeling (BIM) as a planning method in the construction sector require rapid changes in the timber construction industry towards timber planning and construction processes appropriate for timber building in order to maintain the competitive position of timber in the construction industry

PROJECT INFORMATION

Project management

Professorship of Architectural Design and Timber Construction, Prof. Hermann Kaufmann

Chair of Architectural Informatics, Prof. Dr. Frank Petzold

Project partners

AEC3 Deutschland GmbH, München

Holzbaunternehmen Gump & Maier, Binswangen

lattkearchitekten, Augsburg

Prause Holzbauplanung GmbH & Co KG, Lindlar

Duration: 08/2019 - 07/2022

BIMwood is a joint research project of the professorship ‘Architectural Design and Timber Construction’ and the chair ‘Architectural Informatics’ at the Department of Architecture, Technical University of Munich. This three-year project, which brings together the practice partners Prause Holzbauplanung, the BIM experts AEC3 and lattkearchitekten, and the timber construction firm Gump & Maier, started in August 2019; it receives funding under the Renewable Resources program.

Against the backdrop of digital transformation, BIMwood is developing the timber design and construction value chain by using Building Information Modelling (BIM) as the key technology in Architecture, Engineering and Construction (AEC), which has a profound impact on established work practices. The focus is on the further development of methods, tools and behavior in prefabricated timber construction to ensure smooth planning and improve data management processes. The target audience of BIMwood results are decision-makers, planners, and timber construction companies, as well as the software industry, which is reliant on the requirements of timber technology know-how to pursue new developments. The research team is investigating the obstacles to a BIM application in timber construction and, resulting from this, will develop concrete proposals for a timber construction-relevant BIM application, which will then be published in a handbook. If the timber construction branch does not take the first steps towards the BIM planning method, especially as regards urban and large-scale structures, it will not be competitive in the future.

Building Information Modelling (BIM) is increasingly becoming the norm, especially for major projects. The BIM planning method supports communication between various parties as regards the planning, construction and management of buildings. Basically, BIM software is used to create a three-dimensional model of the building. Depending on the agreed depth of information, this consolidates data related to drawings, materials, and products, as well as the quantities and costs of all aspects of the planning process, making them transparent. Modifications of one item in the planning, e.g. the dimensions of a wooden beam, are passed on automatically to all information levels, i.e. floor plans and sections, as well as to the itemized bill of quantities and the cost calculation. Simulations, such as the energy consumption or thermal behavior of components, may also be generated with the help of the data. Everyone involved in the construction process

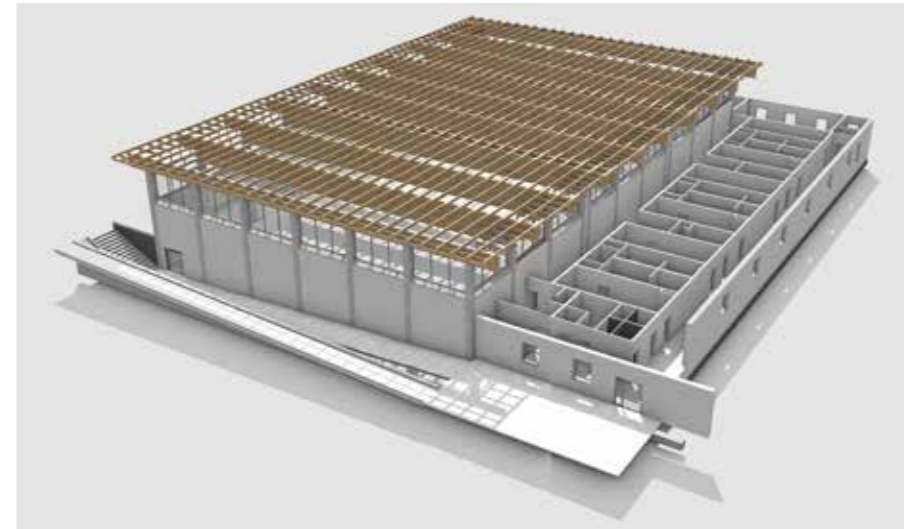
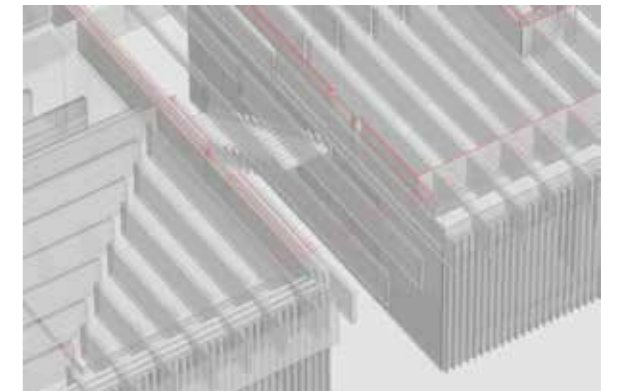

Image above: Building within the existing stock – an inventory model was created as a basis for gymnasium modernization measures

Image right: Section of a BIM model showing a horizontal sectional plane. All pictures: © lattkearchitekten



has access to the model and thus always has up-to-date knowledge. In addition to technical and information technology, BIM entails a new, integrated cooperation and planning method.

BIM and the requirements of modern timber construction were made for each other: just as with the BIM method, prefabricated timber construction requires decisions to be made in the early planning stages. Equally important is the early involvement of timber construction expertise through specialized engineers or timber construction companies. Rectifications cannot be made on the building site. Studies carried out by the preceding project of the Technical University of Munich, leanWOOD (Architectural Design and Timber Construction, 2017), showed that there was still a need for action: timber construction projects with a high degree of prefabrication are often still processed according to the classical, phased sequence which is common in conventional construction. Timber construction know-how is integrated into the process too late. This often leads to lengthy and costly rectifications afterwards. These frictions within the value chain, especially during the planning process and at the interface between planning and execution, hamper the efficient and competitive use of timber and timber products. Consistent data management and appraisal taking into account planning

information, together with machine data delivery and lifecycle data, would constitute a great step towards a successful digital transformation of the industry.

The team assembled around the Technical University of Munich will quickly launch into the studies in order to present the latest findings from BIMwood to the industry, in parallel to the rapidly advancing developments in digital planning. The results of an industry analysis carried out by the preliminary project HOLZundBIM (Architectural Design and Timber Construction, 2019) provide the basis for the beginning of the research work; they shed light on the type and scope of use of the BIM planning method within the entire process chain for timber planning and construction in Germany. The preliminary results of BIMwood will be worked out and discussed concomitantly with experts and fellow researchers in German-speaking countries; they will be compared with the current situation in countries where BIM already has a stronger presence.

The project is being funded by the Federal Ministry of Food and Agriculture (BMEL) through the Fachagentur Nachhaltige Rohstoffe e. V. (FNR) project sponsor.

Final Presentations at Studio „Weisser Saal“

Picture: Bachelor Students, Professorship of
Architectural Design and Timber Construc-
tion, summer term 2019. (Photo: Tassilo Letzel
© TUM Department of Architecture)





Publication: Building Register IV

Studio Krucker Bates have launched the 4th series of Building Register, now available from the Chair of Urbanism and Housing.

The 4th edition includes five building studies:

- Case Franconi, Mario Ridolfi, Terni
- Holland House, Hendrik Petrus Berlage, London
- Les Cotxeres, Josep Antoni Coderch, Barcelona
- Rabenhof, Heinrich Schmid and Hermann Aichinger, Vienna
- 101 Spring Street, Nicholas Whyte, New York

The format follows previous editions with detailed drawings at various scales, descriptive texts and photographs.

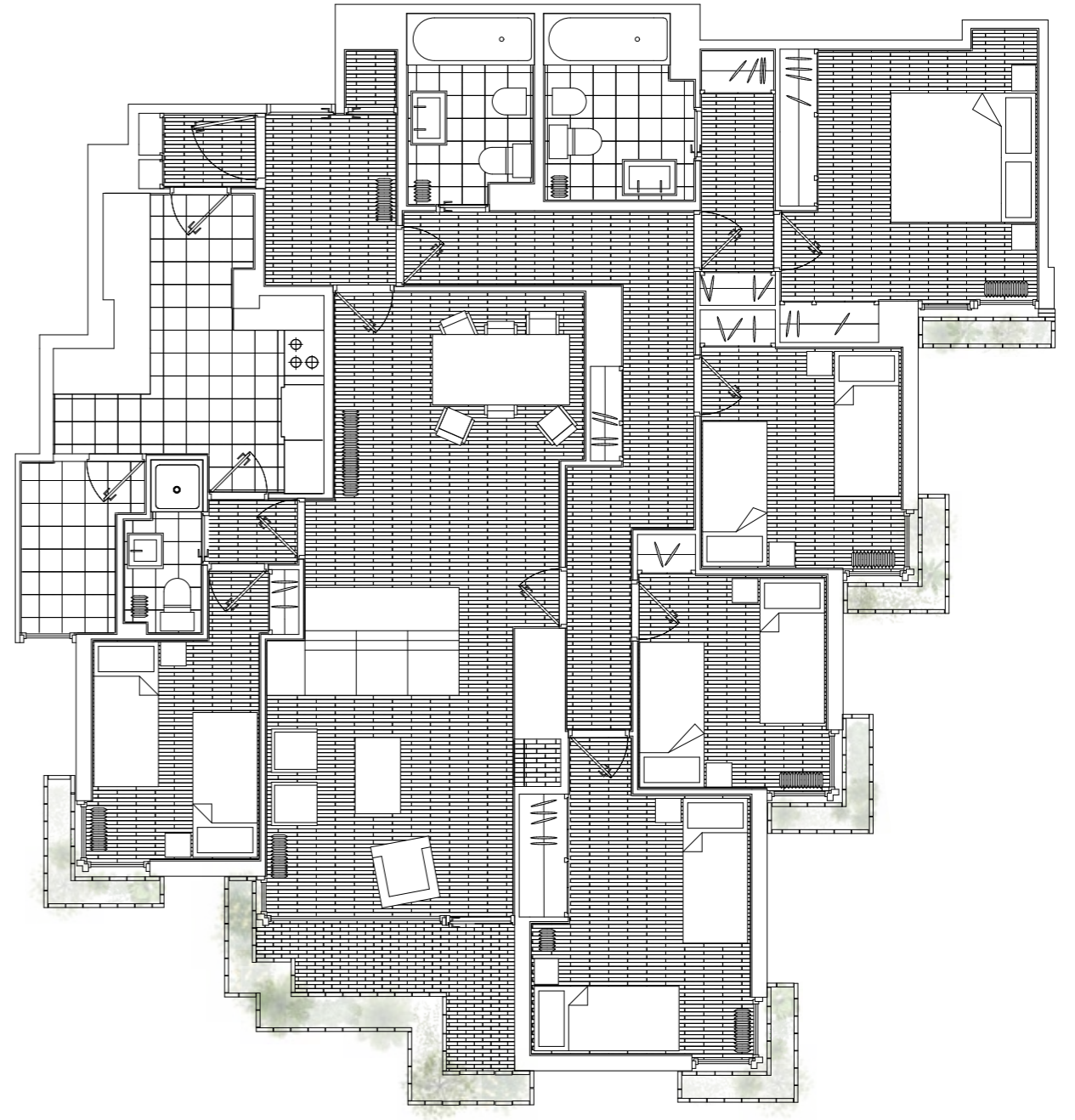
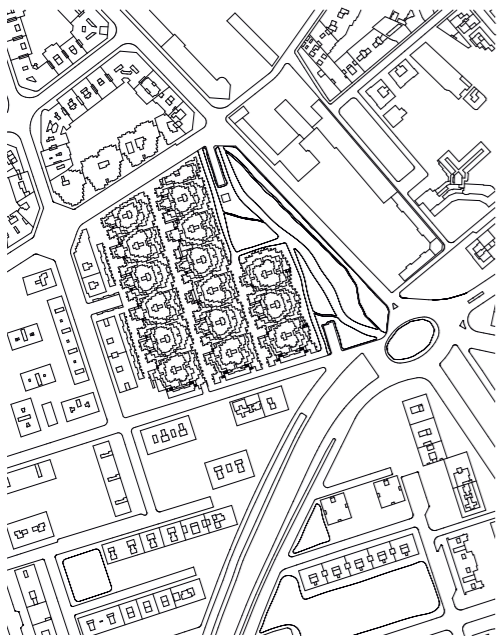

Les Cotxeres

The housing complex of Les Cotxeres is an ensemble of sixteen buildings in the Sarrià-Sant Gervasi quarter in Barcelona on the former site of the municipal tram and bus depot. It was conceived in 1968 by Josep Antoni Coderch as a “superblock” and as an alternative to a 1965 Corbusian-inspired scheme by Antonio Bonet Castellán for the same site. Coderch’s scheme, his largest built residential development, was denser and less costly than the high-rise blocks envisaged by Bonet. It was organized in three rows of similarly scaled volumes with pedestrian walkways between them. The central garden street formed a complex topography with terraces and steps to protect the ground floor areas, shaping a human-scale space from which cars were removed and where residents, commercial activities.

Research Perspectives in Architecture

PROJECT INFORMATION

Conference

Organization

Chair of Architectural Design and Conception, Prof. Uta Graff

Assistant Professorship of Green Technologies, Prof. Dr. Ferdinand Ludwig

Funding

The TUM event was funded by the DFG - German Research Foundation and takes place within BauHow5, the European alliance of five leading research-intensive European universities for architecture.

Objective

According to the opening of the Department of Architecture's mission statement »Architectural design (Entwerfen) is the core of the Department and the exploration of complex aesthetic and spatial solutions its primary objective. [...] The academic discipline of architecture involves skills from different backgrounds including engineering, humanities and social sciences, each of which flows into architectural teaching and research at all levels.«¹ Scientific research in our department has so far merely focused on three out of four focus areas: »Integrated Building Technologies«, »Cultural Heritage, History and Criticism« and »Urban and Landscape Transformation«. In the field of Architectural Design, research projects and Ph.D. are only gradually increasing although this field is referred to as »the core practice, which serves as a common basis for all teaching and research activities.«² The research at the core of our discipline is still fraught with many uncertainties and methods not directly transferable from other disciplines.

So the overarching question is: How can we strengthen research in the core area of architecture?

Structure

The international conference »Research Perspectives in Architecture« took place in July 2019 at the Vorhoelzer Forum of our Department. On the first day, varying research approaches were presented and discussed with specific focus on their respective methodologies applied. The introduction by Prof. Monika Kurath on »Research Culture in Architecture« was followed by five panels, each of which was dedicated to a certain methodological perspective, namely design-based, reflexive, qualitative, perception-based, archival. All panels followed an even structure of an introductory talk on the superordinate methodological framework, three short presentations of research projects and a final discussion among the contributors. The first day closed with an evening lecture by Prof. em. Dietmar Eberle on design as research practice in reference to his publication »Entwurf als Forschungspraxis«. The second day was dedicated to different formats, institutions and discourses for research in architecture. Further, it academics were given the opportunity to present their current research projects, focussing on their methodological approaches. Insights into transdisciplinary approaches as well as genuine architectural methodologies were addressed. Beyond the potentials among neighbouring disciplines, the challenges and chances of an implicit and visible research discourse in architecture was debated.



Image above: Uta Graff, Frank van der Hoeven, Susanne Hauser, Ferdinand Ludwig, Séverine Marguin, © Fotograf: Felix Zeitler, Lehrstuhl für Entwerfen und Gestalten TUM

Fostering the methodological core of each presented research, a deeply profound exchange between the contributors was enabled, because it could be emphasized in regard to the liminal fields of their respective methodological approaches, despite controversial subjects of investigation. Further, the impetus of methodologies originated in the field of architecture as well as transdisciplinary transfer of methodologies and knowledge were debated with even emphasis.

Résumé

The conference opened the realm for profound discussion among all participants with main focus on their methodological approach, but also for exchange between adjacent fields of investigation, on superordinate, transdisciplinary perspectives, across different subjects of research, and into associating fields. The openness towards unconventional approaches allowed productive insights into less common manners of research practice, granting the possibility to not only examine specific research projects against the back-

ground of their individual scientific approach, but rather to investigate research itself. Therewith the conference appeared to be opening a superordinate discourse on the matter of research in the discipline of architecture, including the vast spectrum of aspects inherent to the discipline itself. Concluding, it can be stated, that the conference »Research Perspectives in Architecture« did not only serve as a driving force to define the plurality and richness of research in architecture for the hosting department, but appeared to be an initial impulse for further investigation for all participants, inspiring prospective collaborations, scientific exchange and transfer among the participants and participating institutions.

¹<https://www.ar.tum.de/fakultaet/wir-ueber-uns/mission>, accessed on 28th of May 2019

²ibid.



Images above: Care Protocols is a mixed reality installation for the XII Architecture Biennale São Paulo, 2019. Emerging from a hybrid digital-physical environment, the installation provides an interaction space alienating and gamifying usually invisible maintenance actions.



Exhibition: XII International Architecture Biennale of São Paulo September 10 to December 09.

TUM Professors Kathrin Dörfler, Benedikt Boucsein and Ferdinand Ludwig, as well as Daniel Talesnic, Research Associate at the Chair of History of Architecture and Curatorial Practice and Curator of the exhibition "Access For All – São Paulo's Architectural Infrastructures" at the TUM Architekturmuseum, are taking part in the core exhibition: "Architectures of Everyday". There will also be a book presentation of the Munich exhibition catalogue as part of the official launch of the Biennale.

"Everyday", the curatorial proposal for the XII International Architecture Biennale of São Paulo, addresses the everyday as a framework for investigating how architecture might move forward as a specialized practice of environment-making in the 21st century. From such a vantage point, the São Paulo Biennale constitutes an ideal venue because the everyday there is an agent able to both impact and empower architecture – for better or for worse.

"Everyday" is structured according to three themes: Everyday Stories, Everyday Resources, and Everyday Maintenance. Each showcases research, pertinent architectural and urban projects, speculative works and installations, as well as other spatial interventions that relate to the contemporary dynamics of the everyday.



Inside Out? Recalibrating Munich Metropolitan Region

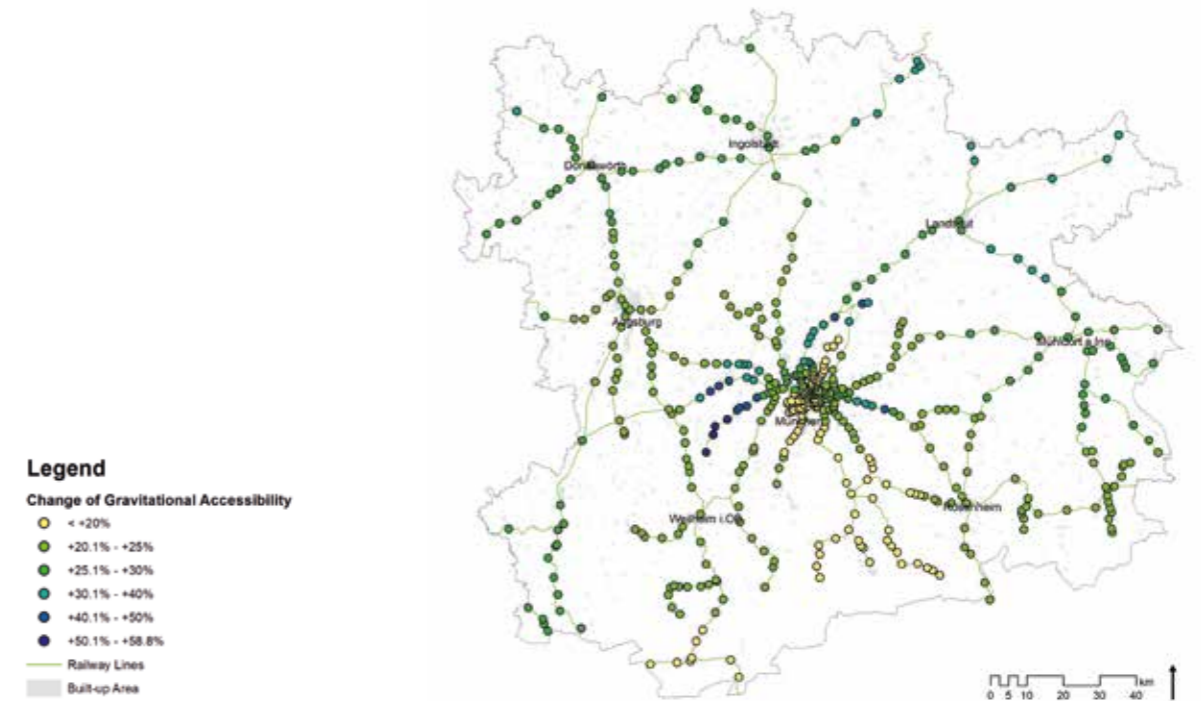

PROJECT INFORMATION

Project partners
Chair of Urban Development
Prof. Dr. Alain Thierstein, Fabian Wenner

Students
Khoi Anh Dang, Melina Hölzl, Alessandro Pedrazzoli, Magdalena Schmidkunz, Jiaqi Wang

The results are documented in a brochure that is available at the Chair of Spatial Development

Changes to railway station accessibility brought about by the second trunk line in the Munich Metropolitan Region. Source: Wenner (2019)

Fast, time-saving access to a large number of people, jobs, and public and private services is one of the most important location factors for businesses and households – and a self-reinforcing driver of settlement growth. Urban planning also aims for well-connected, dense, mixed-use neighborhoods, since these are expected to help create environment-friendly, short commutes and leisure journeys, and to ensure the viability of public facilities.

Agglomerations such as the Munich Metropolitan Region are increasingly suffering from an overheated housing market and a shortage of open spaces while, at the same time, their transportation systems are overloaded. Despite recent innovations in personal transportation, integrated planning of public transit extensions and urban development is needed to provide a sustainable solution. After a long break, a number of new major transit projects are currently being implemented in the Munich Metropolitan Region, in particular the second S-Bahn trunk line for express S-Bahn trains, which is scheduled for completion in 2028.

These transportation projects will revolutionize the 'accessibility map' in the metropolitan region of Munich. Municipalities that so far had been poorly connected will suddenly move 'closer to the center' in terms of journey time. At the same time, an even greater number of people will be able to reach the center of Munich in even less time. In other places, however, the level of accessibility is hardly changing. The study project dealt with the question of what these changes would mean for future spatial development within the metropolitan region of Munich. In the future, which places will become attractive, and for which users, and how should city planning and architecture react to this?

BALKRISHNA DOSHI



Architecture for the People

The Architekturmuseum der TU München presents with the exhibition »Balkrishna Doshi: Architecture for the People« (17 October 2019 to 19 January 2020) the first international retrospective about the 2018 Pritzker Prize laureate Balkrishna Doshi (born 1927, Pune, India) outside of Asia. The renowned architect and urban planner is one of the few pioneers of modern architecture in his home country and the first Indian architect to receive the prestigious award. During over 60 years of practice, Doshi has realized a wide range of projects, adopting principles of modern architecture and adapting them to local culture, traditions, resources, and nature. The exhibition will present numerous significant projects realized between 1958 and 2014, ranging in scale from entire cities and town planning projects to academic campuses as well as cultural institutions and public administrative offices, from private residences to interiors. Among these works are pioneering buildings like the Indian Institute of Management (1977–92), Doshi's architectural studio Sangath (1980), and the famous low-cost housing project Aranya (1989). Exhibits will include a wealth of original works such as drawings, models, and art works from Doshi's archive and studio, but also photography, film footage and several full-scale installations. An extensive timeline will give an overview of the architect's career from 1947 until today, attesting to his close relationships with other influential architects and thought leaders such as Le Corbusier and Christopher Alexander.

House before the arrival of residents in its original configuration: "Housing for Life Insurance Corporation" (LIC), Ahmedabad, 1973. Photo: © by the Vastushilpa Foundation, Ahmedabad

The exhibition »Balkrishna Doshi: Architecture for the People« will open Doshi's work to a global audience and show how the architect's work has redefined modern Indian architecture as well as shaped new generations of architects. Therefore, the retrospective does not only offer an overview of Doshi's architectural work, but also reflect on its underlying ideals and social context. Doshi's humanist philosophy was shaped by his Indian roots as well as his western education and the rapidly changing context of Indian society since the early 1950s. His architectural vocabulary, which is both poetic and functional, was strongly influenced by what he learned from Le Corbusier, with whom he collaborated on the design of the Indian city of Chandigarh and on other projects, and from his experiences with Louis Kahn, who conceived the design for the Institute of Management. Reaching beyond these early models, Doshi developed an approach that oscillates between industrialism and primitivism, between modern architecture and traditional form. His practice is based on ideas of sustainability and aims to root architecture in a larger context of culture and environment as well as social, ethical, and religious beliefs.

The retrospective follows four main themes, beginning with the focus on home and identity and examining the power of architecture to bring about social change. Inspired by Mahatma Gandhi, Doshi developed new approaches to social and experimental housing based on participation and the possibility to adapt to the users' changing needs and requirements, as seen in such outstanding examples as the Housing Development for the

Life Insurance Corporation (LIC), known locally as »Bima Nagar«, in Ahmedabad (1973) and Aranya Low Cost Housing for the Indore Development Authority (1989). Aranya was built as a model project and today accommodates over 80,000 individuals. A modular system allows the inhabitants to customise their homes and adapt them to their needs, their personal preferences, and their economic possibilities. The project was predicated on a »sites and services« approach, in which electricity, water, and sewer services were provided, but the houses were built minimally as a service core that each family could extend. An example for Doshi's residential planning on a smaller scale is his own house, called »Kamala House« (1963). This generous yet economical building with a cross-shaped floor plan maximizes lighting throughout all spaces, while insulated brick walls trap and minimise the summer heat.

The exhibition's second section looks at Doshi's educational buildings. A key project here is the campus of the Center for Environmental Planning and Technology (CEPT) in Ahmedabad, on which Doshi has realized some of his most significant buildings over a period of 40 years. In 1962, Doshi established the School of Architecture, a multi-disciplinary institution grounded in the belief that education is nourished by interdisciplinary interactions. To foster exchange and dialogue among students and department alike, Doshi designed the building as a free-flowing space without compartmentalization or segregation. Both through its buildings and its teachings, the school has changed the face of architectural education in India; it has also become one

Street view of social housing estate: "Aranya Low Cost Housing for Indore Development Authority", Indore, 1989.
Photo: © Vastushilpa Foundation, Ahmedabad



One of the spacious, light-flooded corridors of the "Indian Institute of Management" (IIM), Bangalore, 1977-92.
Photo: © of Vastushilpa Foundation, Ahmedabad: Vinay Panjwani – India

of the country's most important centers for urban planning. While the School of Architecture is raised above the ground on top of an old brick kiln that greatly influenced its plan and layout, the art gallery Amdavad Ni Gufa (1994) on the same campus is half-buried in the ground – »gufa« is Gujarati for »cave« – to solve issues arising from the local climate. While its structure of different-sized mounds integrated into the natural landscape is based on computer-aided design, the construction was carried out by unskilled workers using waste products and simple hand tools.

The third section is dedicated to Doshi's large-scale town planning projects, exemplified by the masterplan and urban design guidelines for Vidhyadhar Nagar (1984), a residential development for 150,000 dwellings located in the outskirts of Jaipur in Rajasthan in northern India. Conceived as an energy-conscious city on a 350-hectare site, it is inspired by the old walled city of Jaipur. An amalgamation of ancient town planning principles, contemporary needs, and contextual realities, the city and its infrastructure were designed to serve the needs of up to 400,000 inhabitants. The social amenities such as schools, health centers, and playgrounds were planned along the linear open space forming the central activity spine. Natural stone, overhangs, and balconies not only helped improve the micro-climate but also recreated the visual experience of the local traditional architecture.

„[...] the retrospective does not only offer an overview of Doshi's architectural work, [...]“



Exterior view of the Premabhai concert hall, Ahmedabad, 1976. © Vastushilpa Foundation, Ahmedabad: Vinay Panjwani – India

The final section of the exhibition revolves around the many institutions Doshi has participated in building during the last 60 years. An important example for this is the Indian Institute of Management (IIM) in Bangalore (1977–1992). The large campus of this institution was built over a period of 20 years in a process that involved numerous additions and alterations. Its courtyards are designed as large gardens, its corridors perceived as interactive nodes of spontaneous communication, while both extend the learning spaces. Pergolas and cut-outs within corridors fringed with greenery transform space through the changing light they receives during the day. With its fascinating architectural conception, the Indian Institute of Management has become an important think tank contributing to India's emergence as an economic power over the last decades. Another milestone in Balkrishna Doshi's institutional architecture is his own studio Sangath in Ahmedabad (1980). Memories of his childhood home and of Le Corbusier's studio in Paris are fused in this building's vocabulary of spaces. »Sangath« means »moving together« in Gujarati, and today three generations of Doshi's family work here side by side. As with all of his buildings, landscape, climate, and purpose are an integral part of his design. Overnight the studio space can be converted into a concert hall or a lecture hall. Surrounded by Ahmedabad's new high-rises and the elevated metro line, Sangath stands as an oasis within the bustling city.

Balkrishna Doshi: Architecture for the People
17 October 2019 – 19 January 2020, Architekturmuseum der TUM
Press conference: October 16, 2019, 1 p.m.
Opening: October 16, 2019, 7 p.m.

An extensive catalogue includes contributions by Kazi Ashraf, Vera Simone Bader, Kenneth Frampton, Khushnu Hoof, Rajeev Kathpalia, Jolanthe Kugler, Hans-Ulrich Obrist, Juhanni Pallasmaa, Samanth Subramanian, Martha Thorne, Nicholas Fox Weber. The presentation at the Vitra Design Museum will be accompanied by a rich program of lectures, talks, and panels as well as workshops and other events.

The exhibition is a project by the Vitra Design Museum and the Wüstenrot Foundation in cooperation with the Vastushilpa Foundation.

Curator: Khushnu Hoof
Vitra Design Museum Curator: Jolanthe Kugler
Assistant Curator: Meike Wolfschlag



Detail view of the roof landscape of the "Amdavad Ni Gufa" art space, Ahmedabad, 1994. © Ivan Baan 2018

View from the garden of Doshi's office building: "Sangath Architect's Studio", Ahmedabad, 1980. © Ivan Baan 2018

Balkrishna Doshi in his office: "Sangath Architect's Studio", Ahmedabad, 1980. © Ivan Baan 2018



Balkrishna Doshi

Born into a traditional Hindu family in 1927, Balkrishna Doshi grew up in the atmosphere of the Indian independence movement championed by Mahatma Gandhi and Rabindranath Tagore. He began his architecture studies in 1947, the year India gained independence, at the Sir J.J. College of Architecture Bombay (Mumbai). In the 1950s, he boarded a ship to London, where he hoped to join the Royal Institute of British Architects, and eventually moved to Paris to work under Le Corbusier. Doshi's association with Le Corbusier and later Louis Kahn lasted over a decade and made the young architect familiar with the vocabulary of modernist architecture with a special emphasis on elemental forms and building materials. In 1956, Doshi opened his own practice in Ahmedabad and called it Vastu-Shilpa («vastu» describes the total environment around us; »shilpa« means to design in Sanskrit). At the age of 35, in 1962, he

founded the School of Architecture at the Center for Environmental Planning and Technology (CEPT) in Ahmedabad. In 1978, Balkrishna Doshi established the Vastushilpa Foundation for Studies and Research in Environmental Design with the aim of developing indigenous design and planning standards for built environments appropriate to the society, culture, and environment of India. Doshi is the recipient of numerous awards and distinctions such as the Global Award for Lifetime Achievement for Sustainable Architecture, the Aga Khan Award for Architecture, and the Gold Medal of the Academy of Architecture of France, among others. He is a Fellow of the Royal Institute of British Architects, the Indian Institute of Architects, and the Institut Français d'Architecture, and an Honorary Fellow of the American Institute of Architects. In 2018, he was the first Indian architect to be awarded the Pritzker Prize.

PowerSKIN Conference 2019

The third skin of human beings – the building envelope – has evolved enormously over the past decades. The role of façades has changed into an adaptive climate control system that leverages synergies between formal, material, mechanical and energy-related components in an integrated design. Contemporary façade planning pursues optimized environmental quality while minimizing the use of resources. Further progress will require the development of sustainable, smart materials as well as active and passive systems that can easily be integrated and maintained.

PROJECT INFORMATION

Conference

- 300 participants
- 30 paper presentations
- 16 nations of 5 continents
- 60/40 split men/women
- Key note speakers
Matthias Sauerbruch | Sauerbruch Hutton
Neil Thomas | Atelier One

Downloads

The papers are published in the PowerSKIN 2019 Conference Proceedings and the Journal of Façade Design & Engineering (JFDE) with open access for download.

PowerSKIN 2019. POWERSKIN CONFERENCE 2019 – PROCEEDINGS. Thomas Auer, Ulrich Knaack, Jens Schneider. ISBN-13 (15) 978-9463661256.

JFDE 2019. Journal of Façade Design & Engineering – Special Issue PowerSKIN 2019. Volume 7. Numer 1. 2019. ISBN 978-94-6366-127-0.

www.powerskin.org

The biennial PowerSKIN Conference addresses the role of building skins to achieve a carbon neutral building stock. This year's topic, "Digital Processes in Façade Design and Construction", dealt with issues such as building operation, embodied energy, energy generation and storage in the context of the building envelope, energy, and the environment.

Prof. Dipl.-Ing. Thomas Auer (Technical University of Munich), Prof. Dr.-Ing. Jens Schneider (TU Darmstadt) and Prof. Dr.-Ing. Ulrich Knaack (TU Delft) launched the PowerSKIN Conference in collaboration with the trade fair BAU 2017. It was the first of a series of biennial conferences integrated in BAU. At this year's BAU (January 2019), architects, engineers and scientists submitted the latest developments and research projects to public discussion. The international scientific PowerSKIN conference aims to build bridges between academic façade research and corporate R&D, but also between research and practice. The following extracts of three papers presented at the PowerSKIN conference 2019 give a small impression of the content:

4dTEX – Exploration of Movement Mechanisms for 3D-Textiles Used as Solar Shading Devices

Fibre-based high-tech materials have long been used in solid and lightweight construction for reinforcement, solar protection and insulation. In this context, the Textile Lightweight Construction Division of the Frankfurt Research Institute FFin is researching dynamic construction components in combination with textile multilayer structures made of so-called spacer textiles (Figure 1).

At the PowerSKIN Conference 2019 Prof. Claudia Lueling and Johanna Beuscher (FFin) presented their research on movement mechanisms for opening and closing, and for controlling view and incident light via spacer textiles aiming for robust and low-maintenance components, respectively. In this way, the spacer textiles temporarily reduce energy loss as well as overheat. Based on traditional sun protection systems such as shutters, venetian blinds and pleated blinds, the FFin is investigating on the controllable daylight management of multi-layer textiles used as moveable elements on a makro-level, as well as movements in the textile structure itself, that is to say in the meso level of the spacer textiles. [Proceeding]



Image left (figure 1): Solar shading element made of folded spacer textile, PowerSKIN 2019, p. 162, Foto: © FRA-UAS /FFin
Image below (figure 3): Rammed Earth Façade at construction stage, Foto: © Lisa Nanz, 2018



Trombe Curtain Wall Façade

The paper of Thomas Wüest and Prof. Andreas Luible from the Institute of Civil Engineering at the Lucerne University of Applied Sciences and Art presented an unconventional redesign of a double skin façade (DSF), based on trombe wall principles, to increase solar gain during the heating season and avoid overheating in summertime. The DSF variant is equipped with a thermal storage mass in the DSF cavity and interior insulation. The thermal mass, in this case concrete, is of a dark color to enhance solar absorption, whereas the shading device is highly reflective. In contrast to traditional Trombe wall systems, this Trombe Curtain Wall (TCW) is not meant to actively heat interior space or transfer thermal energy. Instead, the TCW aims to regulate heat flux within the façade through the management of solar thermal energy fluxes. The U-Value is therefore considerably lower, 0.25 instead of 0.41 for a TCW. The potential to reduce buildings' heat losses through solar energy use.

The TCW shows a high solar energy usage due to its 'natural' overheating tendency. However, heat losses are significantly lower than the U-Value predicts and, in some cases, even lower than the heat losses of a traditional external thermal insulation composite system. Due to its economical use of material and lower weight, the system can be used as a curtain wall system instead of traditional DSFs, which have higher heat losses in winter and higher solar gains in summer. [JFDE]

Impacts on the Embodied Energy of Rammed Earth Façades During Production and Construction Stages

Rammed earth is a sustainable construction technique encompassing the whole life cycle of buildings with a low energy demand. Soil from the excavation can be compressed on-site to build a façade. Due to their hygro-

scopic and thermal properties, rammed earth façades stabilize indoor comfort; this has the potential to minimize the use of mechanical systems. In order to reduce the energy demand for the entire life cycle of a building, embodied energy must be taken into account. Databases such as the German ÖKO-BAUDAT provide data for a life cycle assessment (LCA). Aggregated data at product stages are available as regards rammed earth, but transportation and construction processes have barely been documented. (Figure 2)

Lisa Nanz (TUM) and the co-authors Martin Rauch, Thomas Honermann (LehmTonErde) and Prof. Thomas Auer (TUM) measured and documented the energy demand relating to the transportation, production, and construction of two rammed earth façades. Their paper, presented at the PowerSKIN Conference 2019, provides a more thorough understanding of the entire building process and contributes to expanding the database. The authors conclude that transportation has the largest impact on the embodied energy of rammed earth façades, so it is essential to use local material. Furthermore, the results illustrate the implications of transportation for a life cycle assessment, as well as for other constructions. [JFDE]



MAKE MUNICH WEIRDpanel

26.02.2020 | 18:00 – 22:00 | Utopia Munich

Space for creativity means space for innovation. The sustainability of our city will depend on the opportunities the city offers to experiment and intervene.

Creative people, politicians, scientists and entrepreneurs will discuss the importance of diversity and creativity for a city's future in relation to physical space.

The event is part of the initiative "MakeMunichWeird" launched by Prof. Dr. Isabell Welpé, Prof. Dr. Alain Thierstein, Prof. Dr. Frank Petzold and the Department's Architecture Research Incubator (ARI).

www.makemunichweird.com

NullAchtNeun

In her search for places that break with stereotypical images of Munich and show the sometimes underestimated complexity, the photographer Lena Engel took a journey of discovery in her hometown. She encountered areas that are marked by a variety of intermediate cultural uses, however, in the next few years will be subject to a severe transformation due to increasing gentrification. The result is a poetic confrontation with places of subculture that are in transition: a documentation of spaces, some of which no longer exist in the depicted form.

Catalog "NullAchtNeun" published by StudiO TvdO, Berlin
Photo: Viehhofgelände 2017, "Bahnhwärter Thiel", Wannda e.V.
© Lena Engel, www.lena-engel.de

The City demands our Attention

Designing for better worlds – not for better business

Architects have lost their authority in the realm of two discourses: the discourse on the city, and the discourse on design thinking.

Take the latter: The growing awareness and current use of the term “design thinking” foregrounds a management method, while the synthesis of form and meaning that designers and architects aim for is vanishing. In the 1950s and 1960s, architects took an active part in design research and the science of design. In the 1970s to 1990s, architects served as a sample group being studied for designerly ways of knowing and working. Yet since the 1990s they have disappeared from the field, with a few exceptions. The academic discussion considered design and design thinking as an integrative discipline beyond a specific domain. But the management side, both scholars and practitioners, realized the potential and applicability of design thinking, and the designer approach, to embrace complex and changing environments in business, industry and the market. A design attitude opened up a new direction to cope with uncertainty and ambiguity, and foster innovation in a creative way. From a mindset seeking to create futures that ought to be, design thinking became a five or seven-step method for applying toolkits, post-its, maps and pre-configured canvases, directed towards *The Design of Business* (Martin, 2009) and *Designing for Growth* (Liedtka & Ogilvie, 2011). Fundamental elements were left aside: intuition and aesthetics, the art of criticism, and the trained designer (Verganti 2017).

If we turn to the discourse on the city, the growing awareness and current use of the term “smart city” foregrounds optimization through technology and control, while the sustainability, livability and complexity that designers and architects aim for is disappearing (Hack 2019). How we travel, work, live, consume, or produce in the city have become matters of digitization and computing intelligence – but not of a spatial kind. Entrepreneurial approaches, those of start-ups, corporates and institutions, have begun to re-design the city and reduce its complexity by capturing it with digital tools. They offer fast-produced modules to live in, mobility systems to experience, and surplus production to share. The design approach they apply is design for growth. Though its potential is promising, the city deserves something better.

This revolution will not be televised. Communities and cities already rely on what has been developed and supplied by actors active in the discourses on the city and design today. Architects need to claim back the terms and re-enter the fray. The knowledge base that architects possess, along with the skills and tools they exercise, continuously develop and will create in future, need to be applied to a broader field. It is a duty, as it once was in the 1950s



Container Collective at Werksviertel-Mitte; Photo: © URKERN 2019

and 1960s – when Richard Buckminster Fuller wrote *Operating Manual for Spaceship Earth* (1969), Stewart Brand provided access to tools with the *Whole Earth Catalogue* (1968), Joan Littlewood and Cedric Price envisioned the *Fun Palace* (1964), and Charles and Ray Eames dedicated themselves to *The India Report* (1958) – to develop the design skills for a sustainable nation. Design is required to face the challenges thrown up by our built environments, urban futures, and sustainable development. The future demands our attention, in both discourses, directing design to the design for better worlds, not for better business – and to hack the city.

Christos Chantzaras

References

- Liedtka, J., & Ogilvie, T. (2011). *Designing for Growth: A Design Thinking Tool Kit for Managers*. New York: Columbia University Press.
- Martin, R. L. (2009). *Design of Business: Why Design Thinking is the Next Competitive Advantage*. Boston: Harvard Business Review Press.
- Hack, Y.-L. (2019). *Liveable Smartness – A strategic Proposal for Architects to improve Liveability through Smart City Implementations*. Master's thesis, Department of Architecture. Technical University of Munich. Forthcoming Fall 2019.
- Verganti, R. (2017). *Design Thinkers Think Like Managers: Two strategies linked to uncertainty resolution*. *She Ji: The Journal of Design, Economics, and Innovation* 3(2), 100-102.

Hack the City

UrbanPrototypingLAB for spatial interventions in Munich
 Hosted by ARI and
 Chair of Architectural Informatics (Prof. Dr. Petzold)
 Chair of Urban Development (Prof. Dr. Thierstein)
 Chair for Strategy and Organization (Prof. Dr. Welpe)
 and the transdisciplinary initiative MakeMunichWeird.com
 This collaborative workshop is open to Master's degree students in architecture, industrial design, management, engineering & informatics.

Further information on www.ar.tum.de/ari

Apply now.
 short motivation letter (100 words)
 short CV (200 words)
 short project portfolio, if available (max. 5 pages)
ari@ar.tum.de

The Architecture of Democracy

Recent developments, such as the Brexit referendum, the demagogic rhetoric of Donald Trump, and the re-emergence of far-right parties in Europe, suggest that democracy is currently under threat. A possible strategy to overcome this threat is active political engagement, and participation in political debate and decision-making. But what roles can art and architecture play in safeguarding and strengthening democracy?

PROJECT INFORMATION

Project management

Chair of Theory and History of Architecture,
Art and Design, Prof. Dr. Dietrich Erben, Dr.
Sarah Hegenbart

Lecture series

"Inspirations from the Global South"

The architectural historian Joan Ockman addressed the question 'What Is Democratic Architecture? The Public Life of Buildings' in an essay published in *Dissent* in 2011. The question as such can be traced back to *Democracy: A Man-Search*, a book by Louis Sullivan that was first published only fifty years ago, although it was written much earlier, in 1908. Its central idea was, as Ockman summarizes it,

*"That 'democratic form' is an organically unfolding process and an object of symbolic representation; that it emerges from the collective imagination of a modern, progressive society and is an act of individual poetic genius."*¹

While the "tensions within this conception are evident," they similarly occur "in architecture itself, which erects fixed monuments to serve as spaces for action and participation."² Sullivan's disciple Frank Lloyd Wright eventually "succeeded in transforming 'the architecture of democracy' into a slogan that he brandished throughout his six-decade career."³ Yet the "ideological ambiguities that surround democratic claims by architects point not only to the difficulties of translating political concepts into three dimensions but also to the historical instability of the term democracy itself, which, despite its symbolic value, has frequently amounted to a hurrah word or a safe-conduct pass."⁴

Ockman argued that the "notion of democratic architecture in late-capitalist society has thus become at once more marketable and more elusive as the paradigm has shifted over the last half century from a culture of monuments to one of spectacles."⁵ Ockman concluded that

*"As such – and suspicious as I remain of democracy talk in architecture – I believe it's essential to continue to aspire to 'the possibility for richer, more inclusive expressions of what holds us together as citizens and human beings,' as the historian Casey Nelson Blake has put it."*⁶

In her response to Herbert J. Gans's comments, Ockman underlined "that architecture, whatever else it is (or isn't), is a form of symbolic representation. Although buildings change ownership and get put to varied ideological uses by different regimes (there are many notorious examples of this kind of 'reuse,' for example, in the context of Nazi Germany, where modernist buildings by some of the most progressive architects of the twenties were appropriated for nefarious purposes in the thirties), they also belong to their historical moment and have real cultural effects along with the spatial ones."⁷

„Democracy can be understood as publicly regulated access to resources and the fair distribution of resources.“

Democratic Architecture

Since the beginning of the Twentieth Century, the term "democracy" has undoubtedly belonged to the grand narratives. Jean-François Lyotard's *grands récits* refer to a way of interpreting heterogeneous facts, aspects of knowledge, and divergent beliefs as if they occurred in a historical continuity that ought to legitimate a teleological development.⁸ The implication – if one applied this reading to the case of democracy – is that the gradual implementation of democracy, initially in Western and later in all global societies, claims to be a process constitutive of modernity?. Democracy appears to have played a successful role in the construction of a grand narrative from its inception until now.

Furthermore, democracy has played a substantial role in the self-image of European modernity. In the years after 1960, "democracy" became more than a buzzword for reforms that were considered necessary in order to anchor further rights of participation characteristic of direct democracies into established representative democracies. "Democracy" also became a synonym for societal participation par excellence, which acted as renewed legitimization for forms of government and states. In his essay on "democratization", Wilhelm Hennis stated as early as 1970 that the term had risen above all doubts and excelled in considerate resistance to doubt, and that one already experienced "a kind of heritage protection order" on democracy.⁹

In late postmodernism, admittedly, doubts emerged not only about "grand narratives" but also about the assertiveness of democracy, which was considered as a self-imposed law. Yet in present times, which are characterized by the erosion of Western democracy and the boom of demagoguery, doubts have become inevitable. This historical skepticism necessarily impacts on thinking about the relationship between democracy and the frequently mentioned ideal of a "democratic building".

The simple initial question is: If the notion of democracy as "grand narrative" is, on the one hand, up for discussion and requires continuous updating and if, on the other hand, democracy itself as the central norm of the political ought to be defended, how would a normative conception of "democratic architecture" have to be formulated?

Terms of democracy and architectonic space

First of all, it is necessary to consider the various aspects and the scope of the notion of democracy. It is important to emphasize that under no circumstances these aspects ought to be played off against each other or that they should be seen as mutually exclusive. On the contrary, they complement each other. In terms of formal institutions, the idea of democracy refers to facts such as the separation of powers (legislative, executive, and judiciary), other legitimate institutions, and political practices such as free elections and freedom of opinion. In terms of performative communication, democracy highlights the negotiation of values, norms, and interests in the public sphere – the "public space" – which has been frequently conjured up as a magic term and can be interpreted as the realm of discourse. Finally, in universalistic ethical terms, this idea aims to widely generalize the understanding of democracy. Democracy can be understood as publicly regulated access to resources and the fair distribution of resources. These comprise, in an equally general sense, food, clothing, housing, education, health, gender equality, political participation and much more.

Obviously, this expansion and unfolding of the notion of democracy considerably impacts on the way we think about the relationship between democracy and architecture. Architecture remains tied to the contexts of authority, power and political communication, but equally moves into the sphere of everyday realities,

which can be examined against the backdrop of their democratic condition. With regard to architecture, this involves a significant extension of construction tasks, whose democratic significance has to be examined. One suspects that answers must not be generalized, but can only be generated on a case-by-case basis which, eventually, means for each building under discussion.

Regarding the institutional conception of democracy, mainly state institutions (e.g. court buildings, parliamentary and ministerial buildings, police headquarters and venues for media production) have been scrutinized. The discussion about “democracy and architecture” has primarily concentrated on this group of state buildings and so-called “representational” buildings, frequently using keywords such as “democracy as constructor” and “democratic building”. This group of buildings certainly continues to be of interest.

However, viewing democracy in terms of performative communication expands the perspective towards the architecturally designed “public space”, i.e. to meeting spaces and spaces of the productive economy in the city. This connection leads to pressing questions regarding general access or restrictions, e.g. as regards secured precincts surrounding government buildings or Gated Communities.

The universalistic ethics within the conception of democracy accounts for both initially mentioned instances of official institutions and the “public space”, but adds two fundamental aspects to these: access to resources and resource justice. This generalized conception of democracy establishes the foundation for the discussion of the democratic content of house building, technical infrastructures (water and electricity supply), buildings for education and culture (schools, museums, theatres and so on), health care buildings, or production and commercial sites for the participants of the society concerned. House building, for example, raises the question of the democratic availability of one specific resource: accommodation. With regard to production sites, it has to be assessed who has access to another resource, namely work, and what the working conditions are like on-site.

Case Study: Lecture Series

These questions informed the lecture series “The Architecture of Democracy: Inspirations from the Global South”, which took place during the past summer term. In the lecture series, we focused on the historical moments and cultural effects of art and architecture in the Global South viewed against the backdrop of the functioning of democracy. Recent grassroots movements in African states, such as Burkina Faso and Uganda, have deployed artistic strategies to overthrow corrupt politicians and formulate visions for justice, tolerance and freedom of speech in their countries. In other countries, such as Nigeria and Rwanda, architects have developed spaces for the realization of central democratic values, e.g. dialogue, communal participation, active citizenship

and collective belonging. While the capitalist structures dominant in the West have damaged the political vigor of many Western art projects, one might wonder whether young democracies in the countries of the Global South have much more potential to inspire, activate and engage people into political participation. This is why this lecture series aimed to provide a platform to discuss inspirational art and architecture projects in the Global South, a geographical region that has been marginalized for a long time.

Sarah Hegenbart started off with the question of how Meleko Mokgosi’s history paintings may challenge us to (re-)discover democratic intuitions. Anthony Gardner, who joined us from Oxford, remained skeptical about the colonial connotations that the Western conception of democracy possesses in countries of the Global South. Kate Cowcher introduced us to Industrial Art and Design in Jet Age Ethiopia. Her research on Ethiopia during the Cold War confronts us with alternative political systems, such as communism, that played a pivotal role in African liberation movements.

The lecture series further explored questions such as: Is democracy a suitable political system for countries in the Global South at all? The Nigerian architect Olajumoke Adenowo scrutinized the above, and some related questions, in her lecture “Democracy reflected in Form, Space and Order: Learning from West Africa’s Ancient Empires.”

The Berlin-based academic activist Natasha A. Kelly spoke about her project *The African Diaspora Palace* and the “pastfuture” of black knowledge in Europe. The Nigerian architect Imoudu Oluwaseun Ojo, who is currently based in Leipzig, touched on post-independence modernism and globalization in Ghana. He was followed by Thomas Haakenson from San Francisco, who lectured on “The Architecture and Aesthetics of Apartheid: Dada in South Africa.”

In the year marking the centenary of the Bauhaus, we were particularly pleased to host Christian Benimana, from Kigali in Rwanda, at the end of this lecture series. His African Design Center – described in Arch+ and other magazines as an “African Bauhaus” – enabled us to gain a better understanding of the next generation of African architects and designers.

Dr. Sarah Hegenbart, Prof. Dr. Dietrich Erben



Lecture series: Inspirations from the Global South

April 29 - June 24, 2019

Which role do art and architecture play in the implementation of democratic structures? Recent grass-roots movements in African states, such as Burkina Faso and Uganda, have utilised artistic strategies to overthrow corrupt politicians and formulate visions for justice, tolerance and freedom of speech in their respective countries. In other countries, such as Nigeria and Rwanda, architects have developed spaces for the realisation of central democratic values, e.g. dialogue, communal participation, active citizenship and collective belonging. This lecture series aims to provide a platform to discuss inspirational art and architecture projects in the Global South. This will illuminate the contribution of artists and architects in processes of facilitating environments for democratic engagement.

Speaker: Sarah Hegenbart, Anthony Gardner, Kate Cowcher, Olajumoke Adenowo, Natasha A. Kelly, Imoudu Oluwaseun Ojo, Thomas Haakenson, Christian Benimana

Image: Meleko Mokgosi, Detail from Comrades V, 2015.

Photo: © STEVENSON Gallery and the artist

1 Ockman, Joan: “What Is Democratic Architecture? The Public Life of Buildings,” in *Dissent*, Fall 2011, pp. 65-72, p. 65.

2 Ibid., p. 65.

3 Ibid., p. 65.

4 Ibid., p. 65.

5 Ibid., p. 67.

6 Ibid., p. 72.

7 Ockman, Joan: Reply to Herbert J. Gans “How Can Architecture be Democratic?” in *Dissent*, Winter 2012, p. 119.

8 Lyotard, Jean-François: *La Condition Postmoderne. Rapport Sur Le Savoir* (1979). Paris: Les Editions de Minuit, 2010.

9 Hennis, Wilhem: „Demokratisierung – Zur Problematik eines Begriffs“ (1970), in *ibid.* *Die mißverständene Demokratie*.

Freiburg: Herder, 1973, pp. 26-51, p. 36.

Selection of Publications & Articles

Auer, Thomas; Knaack, Ulrich; Schneider, Jens : PowerSkin Conference Proceeding. . TU Delft Open, TU Delft / Department of Architecture and the Built Environment, 2019

Arvanitakis, Diane; Nitsche, Philipp; Thierstein, Alain; Weinig, Markus (Hrsg.): Rosenheim: In between urban and dense. Technische Universität München, 2019

Fakultät für Architektur der TU München (Hrsg.): Review 2018-2019 – TUM Department of Architecture. Fakultät für Architektur, Technische Universität München, 2019

Alaily-Mattar, Nadia; Büren, Nicolas; Thierstein, Alain: Transforming the media exposure of a city through star architecture projects? DisP - The Planning Review 55 (2), 2019, 36-48

Bentlage, Michael; Thierstein, Alain: Knowledge Networks Change Their Structures. Investigation of Knowledge-Intensive Companies and Research Institutions. Tijdschrift voor Economische en Sociale Geografie forthcoming, 2019

Bock, T., Linner, T., Güttler, J., Iturralde, K.: Ambient Integrated Robotics: Automation and Robotic Technologies for Maintenance, Assistance, and Service – Handbooks on Construction Robotics, Volume 5. Cambridge University Press, 2019

Bock, Thomas; Iturralde, Kepa: La robotisation pour la préfabrication et la mise en œuvre d'une rénovation de bâtiment. 9th edition of the International Wood Construction Forum FBC 2019, 2019

Brasche, Julia: Kommunale Klimapolitik – Handlungsspielräume in komplexen Strukturen. Dissertation, 2019

Eisenberg, Bernd; Well, Friederike; Ludwig, Ferdinand: Neues urbanes Grün - Freistehende Vertikalbegrünung für das Stadtklima. Ernst & Sohn - Special Gebäudebegrünung, 2019



Dietrich Erben. Das Buch der Entwurf - Textgattungen in der Geschichte der Architekturtheorie. Ein Handbuch (The Book of Design - Written Genres in the History of Architectural Theory. A manual), 2019

The authors of these eighteen studies describe the ways in which architecture is spoken about and conveyed through pictorial information, thus analyzing the communicative conditions of architectural theory. For the first time, a historical survey ranging from the Renaissance to the present systematically examines the various written genres, such as: treatise, dialogue, commentary, essay, antiquarian publication, exhibition catalogue, or architecture journal, in their meanings as “contracts” between authors and the audience in different social contexts. Choosing a particular written genre is not just a major design decision on the part of the author. For a genre will both display the shackles of tradition and the thrust towards innovation in architectural theory. In this way, the written genres of architectural theory themselves function as agents of knowledge production; they denote the continuous development and adaptation of theory to every new contemporary construction need. Written genres have promoted the modernization of architectural theory – this is the argument around which this handbook revolves.

Fakultät für Architektur TUM: Abschlussdokumentation B.A. + M.A. Wintersemester 2018/19. Fakultät für Architektur TUM, 2019

Ferravante, Vittorio.; Riva, Emanuele.; Taghavi, Meysam.; Braghin, Francesco .; Bock, Thomas.: Dynamic analysis of high precision construction cable-driven parallel robots. Mechanism and Machine Theory 135, 2019, 54-64

Frohwein, Europa; Putz, Andreas: Zeugnisse einer großen Baustelle. Münchens altgewordene U-Bahnhöfe. Internationale Tagung ICOMOS Deutschland / Landesdenkmalamt Berlin (Berlin Underground Architecture Revisited), 2019

Gadelhak, Mahmoud: A Computational Framework for the Optimization of the Environmental Performance of Facades in Early Design Stages. Dissertation, 2019

Gfirtner, Stefan Sebastian: Entwicklung und Validierung eines 3-D Brustmodells zur virtuellen OP-Planung von Mammaprothetiken. Dissertation, 2019

Güttler, Jörg: Development of an Ambient Health Monitoring System for a Self-Sufficient and Independent Life in Old Age. Dissertation, 2019

Hensel, Tim: Investigating epigenetic alterations in Ewing sarcoma – A prospective and promising approach to future therapeutic treatment of ES patients. Dissertation, 2019

Hu, R.; Kabouteh, A.; Pawlitza, K.; Güttler, R.; Linner, T.; Bock, T.: Developing Personalized Intelligent Interior Units to Promote Activity and Customized Healthcare for Aging Society. 36th International Symposium on Automation and Robotics in Construction (ISARC 2019), 2019, 234-241

Ilhan, B., Bock, T., Linner, T., Iturralde, K., Pan, W., Hu, R.: Innovative Robotics and Automation for Offsite Manufacturing. In: Goulding, J., Rahimian, F. P. (Hrsg.): Offsite Production and Manufacturing for Innovative Construction: People, Process and Technology. Routledge, 2019

Iturralde, Kepa; Kinoshita, Taku; Bock, Thomas: Grasped Element Position Recognition and Robot Pose Adjustment during Assembly. 36th International Symposium on Automation and Robotics in Construction , 2019, 461-468

Keltsch, Michael Joachim: Niedrigstenergiestandard für Nichtwohngebäude – Empirische Potentialstudie zur Realisierbarkeit eines Niedrigstenergiestandards bei Nichtwohngebäuden mit hohem Energiebedarf. Dissertation, 2019

Lu, Y.; Steenbakkens, J.; C.A.L., Valk; Bekker, M.M.; Boom, C.v.d.; Mural, S.: Collaboration network organization: Summarization of the outcomes of the design and the stimulation of the collaboration network – REACH2020 Deliverable D35. 2019



Lepik, Andres; Strobl, Hilde: Die Neue Heimat (1950-1982), 2019

Neue Heimat was the largest and most significant non-state housing corporation in post-war Europe. Over a period of more than thirty years, the trade union-led corporation planned and built over 400,000 apartments and also, from the 1960s, numerous municipal and commercial buildings in Germany. Neue Heimat was a bearer of hope for participation in the economic miracle, so the scandal-ridden collapse of the company in the early eighties came as a veritable shock to the West German population. More than one generation later, we now have an opportunity for a critical reappraisal: what was the social democratic vision based on, and what has become of the aspiration to “housing for all”, which is still alive today? Large-scale housing estates (such as the Neue Vahr Bremen or the overspill town Neuperlach) as well as gigantic Neue Heimat major urban development projects (such as the ICC Berlin) are documented in the book thanks to a large number of historical photographs, plans, and short contributions.

Modica, Marcello: Industrial Brownfield Sites in the Alps. A first Quantitative Overview and Potential Implications for Regional Development. Revue de géographie alpine (107-1), 2019

de Marco, Ario: Reshaping metropolitan transportation cultures. A comparative study of bicycle friendly cities in Europe and the case of the Metropolitan City of Milano. Dissertation, 2019

Molter, Philipp Lionel; Fellner, Jakob; Forth, K.; Chokhachian, Ata: Adaptive Bricks: Potentials of Evaporative Cooling in Brick Building Envelopes to Enhance Urban Microclimate. JANUARY 17TH 2019 – MUNICH POWERSKIN CONFERENCE, 2019



Molter, Philipp Lionel; Hauser Oke: Shared Urban Futures - History and Future of Collaborative Living Concepts, 2019

A global trend towards urbanization in the last century led to smaller and denser households as well as dramatic increases in real estate prices and rents. Today, more people live in urban areas than in rural areas around the globe, a trend that is likely to continue. In 2050, more than 70 per cent of the world's population is projected to be urban. Worldwide real estate markets have demonstrated that traditional business concepts as well as architectural layouts of urban dwelling are unable to respond to the needs of our changing society. The evidence for a changing society and new forms of lifestyle has necessitated a vast change in contemporary urban living, leading to collective building typologies. The idea of collective housing, centered on sharing and participation, proposes alternative strategies to dysfunctional housing markets in urban environments.

Neykova, Sevdalina: Keep It or Lose It: Preservation Strategies for Archaeological Sites. Dissertation, 2019

Pehr, S.; Zollitsch, D.; Güttler, J.; Bock, T.: Development of a Non-Contact ECG Application Unobtrusive Embedded into a Bed. 2019 IEEE Sensors Applications Symposium (SAS), 2019

Putz, Andreas: An der Oberfläche [Rezension: Monika Wagner: Marmor und Asphalt. Soziale Oberflächen im Berlin des 20. Jahrhunderts. Berlin, Verlag Klaus Wagenbach 2018]. *kunstchronik* (4), 2019, 177-183

Putz, Andreas: Housing Paul and Paula. Building Repair and Urban Renewal in the German Democratic Republic. *Architectural Histories*, 2019

Putz, Andreas: Wo Paul und Paula lebten. Zur Erhaltung und „Rekonstruktion“ des Baubestands in der DDR. In: Mager, Tino; Trötschel-Daniels, Bianka (Hrsg.): *Rationelle Visionen. Raumproduktion in der DDR*. Bauhaus Universitätsverlag, 2019, 80-99

Putz, Andreas: Housekeeping. Muster im Umgang mit dem Bestand. Ein denkmalpflegerischer Blick. Konferenz zur Ausstellung Neue Heimat, Architekturmuseum der TU München, 2019

Putz, Andreas: Stilarchitektur und Baukunst – Stilgeschichte und Bauforschung. Wandlung des Fachs im Zuge der Einführung des Promotionsrechts an den Technischen Hochschulen. Konferenz Institut für Kunstgeschichte, Bauforschung und Denkmalpflege TU Wien (Kunstgeschichte an Polytechnischen Instituten, Technischen Hochschulen und Technischen Universitäten. *Geschichte, Positionen, Perspektiven*), 2019

Putz, Andreas: „Komplexe Rekonstruktion“ Zur Kritik der industriellen Baureparatur. Vierte Jahrestagung der Gesellschaft für Bautechnikgeschichte, Hannover, 2019

Putz, Andreas: Towards the re-reading of the 20th Century principles of architectural conservation-restoration. *Heritage for Future*, Lublin University of Technology, 2019; *Conservation Ethics Today: Are our conservation-restoration theories and practice ready for the 21st century?*, 153-164

Putz, Andreas: Der angemessene Baupreis – Zur Kalkulation und Normierung des traditionellen Bauens in den 1930er-Jahren in der Schweiz. “Mit den wohlfeilsten Mitteln dauerhaft, feuersicher und bequem” Sparsamkeit als Prinzip, Rationalität als Weltsicht?, *Thelem*, 2019; Tagungsband der Dritten Jahrestagung der Gesellschaft für Bautechnikgeschichte, 47-68

Ripp, Matthias; Çavdar, Meltem; Hauer, Susanne: *Heritage-Based Urban Development: The Example of Regensburg*. In: Pereira Roders, Ana; Bandarin, Francesco (Hrsg.): *Reshaping Urban Conservation*. Springer, 2019, 435-457

Schneider-Marin, Patricia; Dotzler, Christina; Röger, Christine; Lang, Werner; Glöggler, Jens; Meier, Klara; Runkel, Susanne: *Design2Eco. Lebenszyklusbetrachtung im Planungsprozess von Büro- und Verwaltungsgebäuden - Entscheidungsgrundlagen und Optimierungsmöglichkeiten für frühe Planungsphasen – Abschlussbericht*. Bundesinstitut für Bau-, Stadt- und Raumforschung (BBSR), Fraunhofer IRB Verlag, 2019

Schwan, Lukas Karl: Steigerung der Lüftungseffektivität von Solarkaminen durch thermische Aktivierung und Nutzung von Windeffekten. Dissertation, 2019

Seitz, Andreas Horst Nikolaus: *An Architectural Style for Fog Computing: Formalization and Application*. Dissertation, 2019

Stamm, Jennifer Lara Elisabeth: *Korrelation rechtsventrikulärer Hypertrophie und rechtsventrikulären Drucks mittels kardiovaskulärer Magnetresonanztomografie und invasiver Druckmessungen*. Dissertation, 2019



Alaily-Mattar, Nadia; Ponzini, Davide; Thierstein, Alain: About Star Architecture Reflecting on Cities in Europe, 2019

Cities worldwide have been resorting to star architects to brand projects, spark urban regeneration and market their image internationally. This book shifts the attention from star architects to star architecture, arguing that star architecture is the product of a process involving multiple actors. Star architecture is better studied in its relationship with urban transformation. The nineteen chapters of this work present a multidisciplinary collection of expert contributions in the fields of urban planning/economics, architecture, media studies, geography, and sociology. Drawing on an array of case studies of over twenty cities in Europe and a range of analytical techniques, the book presents both the positive and more problematic impacts of star architecture, with reference to tourism, the media, and the preservation of built heritage.

Trüby, Stephan, Hartbaum, Verena, University of Looking Good & c/o Now. Bayern, München - 100 Jahre Freistaat. *Eine Raumverfälschung (Bavaria, Munich – A Free State 100 years ago. A distortion of space)*, 2019

Weilacher, Udo: *Parki rzezby dzisajj - salony pieknosci pod golym niebem?* In: *Rzeźba Dzisiaj 3. Centrum Rzeźby Polskiej w Oronsku*, 2019, 13-22

Weilacher, Udo: *Sculpture Parks Today - Open Air Beauty Parlors?* In: *Sculpture Today 3. Centre of Polish Sculpture in Oronsco* (1. Aufl.), 2019, 215-222

Wenner, Fabian: *High-Speed Rail and Interlocking Firm Networks of the Knowledge Economy in Germany*. Annual Meeting of the Association of American Geographers (AAG), 2019

Wenner, Fabian: *High-Speed Rail and Interlocking Firm Networks of the Knowledge Economy in Germany*. Regional Studies Association (RSA) Annual Conference, 2019

Wenner, Fabian; Caset, Freke; De Wit, Bart: *Conference Locations and Sustainability Aspirations: Towards an Integrative Framework?* *DisP - The Planning Review* 55 (1), 2019, 34-51

Yordanova, Mariana: *Lichtinszenierungen für Gebäudefassaden – unter Berücksichtigung von energieoptimierenden Maßnahmen und dem Erschließen von Synergieeffekten mit einem nachhaltigen Mehrwert*. Dissertation, 2019



SOLANGE ICH
VON KARRIERE REDE
UND DU
FAMILIENMANAGEMENT
MEINST,
BIN ICH FEMINISTIN.

SOLANGE

Dust protection nets embroidered with cable ties and tulle are mounted on construction sites. Large-format messages embroidered in traditional cross-stitch illustrate the continuing need for feminist demands. The subject areas for the slogans have been developed through numerous discussions with women and men around the topic of feminism. The focus is on questioning current social power structures. So far, seven construction site coverings have been realized in Austria. Two more nets have just been assembled in Rabat, Morocco. An expansion of the project to other countries is being planned and collaboration partners are sought. For Katharina Cibulka and her team, SOLANGE is literally about penetrating a classically masculine industry by means of pink-embroidered sentences applied to dust protection nets. Although the demands are not new, they are intended to communicate a feeling of conspicuous insistence in public space. www.katharina-cibulka.com
Photograph © Felix Richter

Staff

01.09.2019

Professors

Thomas Auer
 Dr. Rainer Barthel
 Stephen Bates
 Dr. Thomas Bock
 Dr. Benedikt Boucsein
 Hannelore Deubzer
 Dr. Thomas Danzl
 Dr. Kathrin Dörfler
 Dr. Dietrich Erben
 Dietrich Fink
 Fritz Frenkler
 Uta Graff
 Tina Haase
 Andreas Hild
 Hermann Kaufmann
 Regine Keller
 Diebedo Francis Kéré
 Bruno Krucker
 Dr. Werner Lang
 Dr. Andres Lepik
 Dr. Ferdinand Ludwig
 Mark Michaeli
 Florian Musso
 Dr. Elke Nagel
 Florian Nagler
 Dr. Frank Petzold
 Dr. Andreas Putz
 Dr. Sören Schöbel-Rutschmann
 Dr. Alain Thierstein
 Dr. Udo Weilacher

Emeriti of Excellence

Dr. Thomas Herzog, Peter Latz, Dr. Winfried Nerdinger

TUM Distinguished Affiliated Professors

Dr. Uta Hassler, Dr. Helmut Jahn, Dr. Dieter Rams

Adjunct Professors

Stephan Lintner, Ralph Egermann, Martin Klingler, Dr. Iris Lauterbach, Lothar Marx, Dr. Matthias Ottmann, Peter Pfab, Mathias Pfeil, Christiane Thalgott

Visiting Professors & Lecturers

Bill Addis, Olajumoke Adenowo, Michael Aimilios, Jaume Mayol Amengual, Fritz Auer, Philipp Auer, Silvia Benedito, Tomà Berlanda, Nicolai Bo Andersen, Alexey Bulgakov, Esfandiar Burman, Matthias Castorph, Victoria von Gaudecker, Michael Hensel, Rainer Hofmann, Christian Inderbitzin, Bahriye Ilhan, Kasper Gulda-

ger Jensen, Elias Knubben, Gemma Koppen, Andreas Kretzer, Reinhard Kropf, Torsten Lange, Sandra Loschke, Rodrigo Pérez de Arce, Irene Pérez Piferrer, Elke Reichel, Wolfgang Rossbauer, Mikala Holme Samsøe, Meike Schalk, Julia M. Schlegel, Siv Helene Stangeland, Tanja C. Vollmer

Lecturers

Friedrich Amann, Philipp Auer, Thomas Bade, Florian Beck, Tomá Berlando, Jörg Besser, Sven Bibi, Robert Biedermann, Susanne Brunner, Gabriella Canciolo, Matthias Castorph, Katharina Cibulka, Claudia Denk, Patrik Dietemann, Birgit Dietz, Hagen Fendler, Christian Flörs, Zuzana Gierlová, Erhard Glaser, Andreas Gruber, Nicola Hanke, Georg Hausladen, Michael Heinrich, Markus Heinsdorff, Regine Hess, Rainer Hofmann, Sandra Hofmeister, Charlotte Holzer, Elisa Huber, Christian Inderbitzin, Kasper Jensen, Werner Jordan, Andrea Kaiser, Christian Kayser Christian, Simon Kimberger, Julius Klaffke, Martin Klingler, Detlef Knipping, Oliver Kraemer, Tobias Kramer, Andreas Kretzer, Meike Kröncke, Markus Lanz, Günter Lattermann, Theres Lehn, Waleska Leifeld, Anna Luib, Elena Markus, Anna Meister, Elisabeth Merk, Eckard Mommert, Isabel Mühlhaus, Ana Neiva, Andreas Nütten, Thomas Richter, Katrin Rohr, Philline Rose, Mikala Samsøe, Barbara Schelle, Lars Schiemann, Karlgeorg Stork, Katharina v. Miller, Wiepke van Aaken, Victoria von Gaudecker, Krista Henrike von Werder-Zyprian, Ulrich Walter, Reinhard Weitzel, Laura Windisch, Esther Wipfler, Frauke Zabel

Guest Speakers

Olajumoke Adenowo, Christian Amlong, Iro Armeni, Fritz Auer, Karen Lee Bar Sinai, Christian Benimana, Manuel de Borja Torrejon, Julia Brandt, Winfried Brenne, Angelo Bucci, Berthold Burkhardt, Esfandiar Burman, Philip Christou, Maria Conen, Gita Cooper-van Ingen, Kata Cowcher, Ekkehard Drach, Dietmar Eberle, Benjamin Eggermont, Donatella Fioretti, Oya Atalay Franck, Alexander Fthenakis, Anthony Gardner, Andrea Gebhard, Kaye Geipe, Theresia Gürtler Berger, Meredith Haaf, Thomas Haakenson, Yonne-Luca Hack, Ivo Hammer, Sarah Hegenbart, Manfred Heinlein, Markus Heinsdorff, Gunter Henn, Sonja Hnilica, Frank van der Hoeven, Andreas Hofer, Kiran Hug, Christian Inderbitzin, Jun Igarashi, Alfredo Jaar, Stephan Jentsch, Daniela Karl, Natasha Kelly, Layla Keramat, Gordian Kley, Burkhard Körner, Monika Köstlin, Yannis Kourayos, Monika Kurath, Fernanda Leite, Werner Linnenbrink, Séverin Marguin, Monika Markgraf, Lissa Meinberg, Elisabeth Merk, Jürgen Meyer, Michael Mönninger, Winfried Nerdinger, Aenne Ohnesorg, Imoudu Oluwaseun Ojo, Goulielmos Orestidis, Jenny Osuldsen, Claudia Pasquero, Gerda Peter, Muck Petzet, Vilma Pflaum, Helge Pitz, Dennis Pohl, Thomas Princen, Liu Qibo, Daniel Röhr, Sharon Rotbard, Tina Saaby, Kerstin Sailer, Tom Shaked, Aaron Sprecher, Matthias Strauss, Jo Taillieu, Christiane Thalgott, Philip Tidd, Isabel Wagner,

Heiner Walker, Sarah Wehmeyer, Marcus Weisen, Rainer Wetzels, Isabel Zintl

Research Associates

Nadia Alaily-Mattar, Ferdinand Anton Victor Albrecht, Hubert Anneser, Diane Arvanitakis, Martin Augenstein, Vera Simone Bader, Stefan Bannert, Marie Bauer, Alexandra Bauer, Ann Katrin Bäumler, Martin Baur, Jonas Bellingrodt, Michael Bentlage, Barbara Berger, Ernest Berghofer, Lukas Beyerle, Ulrich Binder, Catharina Blänsdorf, Christian Bodensteiner, Lea Bogischef, Diana Böhm, Lorenz Boigner, Cécile Bonnet, Julia Brasche, Ivan Bratoev, David Briels, Barbara Brinkmann, Sina Brückner-Amin, Patrick Brunner, Simon Burko, Tobias Busen, Elettra Carnelli, Dennise Alejandra Castillo Calle, Meltem Cavdar, Christos Chantzaras, Ata Chokhachian, Daniel Dabringhausen, Ines Dantas Ribeiro Bernardes, Manuel De Borja Torrejon, Zeno Dietrich, Sen Dong, Elke Dreier, Claudia Düll-Buchecker, Carmen Duplantier, Anita Edenhofer, Benjamin

Tobias Haag, Christian Hadaller, Doris Hallama, Johann-Christian Hannemann, Lutz Harrer, Benedikt Hartl, Sebastian Haß, Nadja Häupl, Sarah Hegenbart, Maximilian Benedict Heidecker, Ute Heim, Karl Martin Heißler, Claudia Hemmerle, Maria Hennl, Christian Hepf, Regine Heß, Sandra Hirsch, Lisa Höpfl, Rongbo Hu, Stefan Imhof, Kepa Iturralde Lerchundi, Tilmann Jarmer, Dominik Jelschewski, Sarah Louise Jenney, Amir Kabouteh, Andrea Kaiser, Wolfgang Kaiser, Veronika Kammerer, Marco Kellhammer, Sabine Kern, Matthias Kestel, Johannes Peter Kifinger, Johanna Kleinert, Miriam Knechtel, Mathias Kocher, Sebastian Kofink, Tobias Kogelnig, Maren Kohaus, Michael Kraus, Andrij Kutnyi, Christoph Langenhan, Katharina Langosch, Lukas Lauss, Uta Leconte, Vanessa Lehner, Yvonne Leinfelder, Thomas Linner, Laura Loewel, Felix Lüdicke, Mauritz Lüps, Anton Mang, Elena Markus, Nicole Meier, Irene Meissner, Claudia Mendes Bernhard, Wilfrid Middleton, Marcello Modica, Philipp Molter, Luc Morroni, Michael Mühlhaus, Andrea Mühlmann,

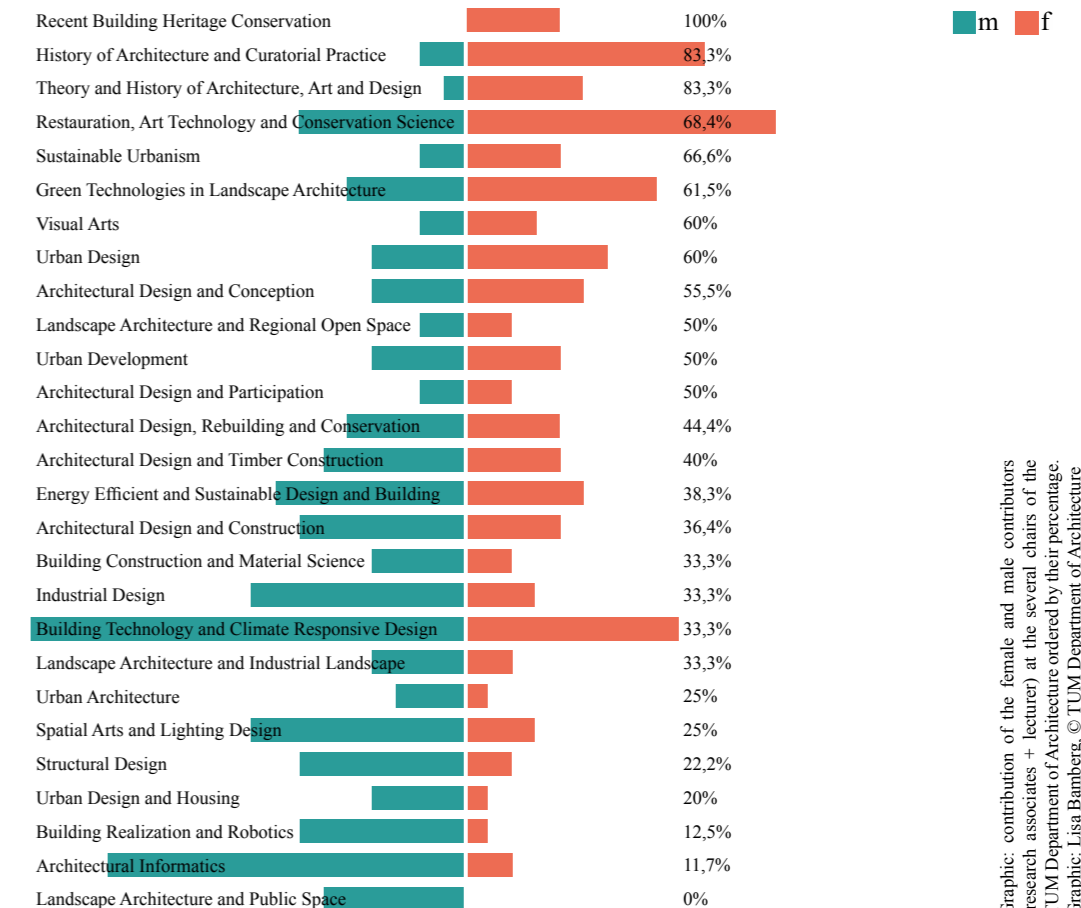

Graphic: contribution of the female and male contributors (research associates + lecturer) at the several chairs of the TUM Department of Architecture ordered by their percentage. Graphic: Lisa Bamberg, © TUM Department of Architecture

Eder, Denise Ehrhardt, Bernd Eisenberg, Teresa Fankhänel, Horst Fark, Faraneh Farnoudi, Elisabeth Faßbender, Tina Fehlhaber, Elif Simge Fettahoglu Özgen, Roberta Fonti, Kasimir Forth, Tobias Förtsch, Laura Franke, Nadine Fritz, Europa Frohwein, Adam Gielnik, Irina Carolin Glander, Isabel Glogar, Rudolf Graf, Betka Graff-Zakirova, Andreas Groth, Lena Stephanie Grüner, Johannes Gump, Jörg-Friedrich Güttler,

Bettina-Maria Müller, Christiane Müller, Imke Mumm, Moritz Mungenast, Andreas Müsseler, Elke Nagel, Katleen Nagel, Gregor Nagler, Lisa Nanz, Jonathan Natanian, Marco Neuß, Anne Niemann, Julian Nummerberger, Wen Pan, Anna Partenheimer, Katja Pawlitza, Kim Peper, Claudia Peter, Alberto Pottenghi, Indrawan Prabaharyaka, Sophia Pritscher, Klaus Puchta, Vesna Pungercar, Mohammad Asrafur Rahman, Alexandra

Rauch, Simon Rauchbart, Benedict Rechenberg, Jörg Rehm, Sophie Reiner, Thomas Reiser, Felix Remter, Judith-Elisabeth Resch, Markus Riese, Andreas Ringelhan, Anastasios Roidis, Nils Rostek, Florian Rüger, Dorothee Rummel, Hannelore Rung, Anja Runkel, Cornelia Saffarian, Ana Sammeck-Lühr, Daniele Santucci, Julian Schäfer, Viola Scheumann, Jonas Schikore, Elena Schirnding de Almeida e Silva, Marcel Schlandt, Eike Schling, Peter Schmid, Thomas Schmid, Anja Schmidt, Michael Schmölz, Ute Schneider, Gerhard Schubert, Barbara Schudok, Christian Schühle, Werner Schührer, Andreas Schulze, Sandra Schuster, Stefanie Seeholzer, Nils Seifert, David Selje, Clarimma Sessa, Kevin Siegert, Tatiany Stamatelatos, Erich Steinhardt, Mathias Stelmach, Hans Heinrich Stengel, Uta Stettner, Manfred Stieglmeier, Hildegard Strobl, Defne Sunguroglu Hensel, Meysam Taghavi, Daniel Talesnik, Oliver Tessin, Nadia Thalgueter, Joram Tutsch, Philipp Vohlidka, Katharina Voigt, Anne Carina Völkel, Julian Wagner, Tobias Wagner, Isabel Wagner, Jens Weber, Markus Weinig, Friederike Well, Fabian Wenner, Andreas Westner, Wotan Wilden, Frauke Wilken, Stefan Wischnewski, Barbara Wolf, Kilian Wolf, David Wolfertstetter, Andreas Wolter, Sascha Peter Wurm, Mariana Yordanova, Oliver Zadow, Ata Zahedi, Felix Zeitler, Tobias Zervosen, Christine Zettelmeier, Isabel Zintl, Maximilian Zitzelsberger, Khaled Mohamed Naguib Zoheir Mostafa, Christian Zöhler, Daniel Zwangslleitner

Tutors

Ahmed Agha, Christoph Ammer, Jonatan Anders, Maria Susana Andrade Zurita, Deniz Arda, Alexander Arndt, Harald Augustin, Theresa Bader, Jakob Bahret, Camilla Baier, Lisa Bamberg, Tobias Bauer, Farida Bendary, Yasmin Biadsi, Larissa Böhrkircher, Lena Bonengel, Tomas Bongart, Philipp Brodbeck, Mari Brorsen, Ilinca-Ioana Bucur, Michaela Burchard, Nina Burri, Jana Calatrava, Tatiana Chatziioannou, Maximilian Christ, Thorfun Chutchawanjumrut, Lorena Cirillo, Maria Cecilia Collet Heller, Luca Coromines, Philipp Cronenberg, Charlotte Dahmen, Janet Do, Thomas Doleschel, Teresa Donner, Susanne Dreyer, Lluís Daniel Dura Monteiro, Andrea Eberle, Alina Eckl, Josef Eglseder, Mirjam Elsner, Frederic Engasser, Gero Engeser, Patricia Eschey, Nils Fischer, Cristina Fischer de Saa, Roman Freistätter, Nils Fröhling, Johann Finn Fukas, Martin Gabriel, Maximilian Gemsjäger, Deniz Genc, Alexandra Gfrörer, Anna Gonchar, Lisa Göppel, Clivia Gröber, Rouven Grom, Teresa Gstöttl, Jinming Gu, Nora-Maria Guzu, Tabea Haeseler, Anna-Teresa Hägele, Tobias Hainz, Miriam Häring, Thomas Haseneder, Niklas Heese, Barbara Helena Hefner, Eva Heidke, Maria-Dolores Heinrich, Lisa Henicz, Daniel Eduardo, Hernandez Acacio, Sebastian Hezinger, Benedikt Hilbich, Lena Jaeger, Franziska Jung, Taku Kinoshita, Florens Caspar Kleiner, Regina Klinger, Jonas Kögl, Fabian Konopka, Alexander Konther, Tonderai Koschke, Franziska Kulinski, Laura Lehmacher, Christoph Leick, Yue Li, Zhiyi Li, Anna List, Maximilian Loeschke, Patricia Loges,

Marc Mair, Cyprian Manthey, Anna-Maria Mayerhofer, Veronika Mayr, David Meier, Andreas Meier, Samuel Meile, Wolfram Meiner, Sweety Mohanty, Franziska Mühlbauer, Florian Muhr, Marlene Müller-Brandeck, Raluca Muntean, Jinda Nasro, Svenja Nevermann, Tobias Niebhagen, Alexandra Niedermayr, Pia Nürnberger, Serena Oberecker, Franziska Odametey, Katharina Ohrner, Max Panhans, Laura Pastior, Mak Pavelic, Stefan Pehr, Eva-Maria Peis, Johannes Pelz, Clara Pollak, Nelly Prechtel, Amelie Pretsch, Kristina Pujkovic, Martin Rehm, Lea Reiter, Daniel Renn, Luise Eva-Maria Richter, Elena Rigato, Eva Ruof, Sebastian Sager, Vanessa Salm, Desiree Antonia Schäfer, Christian Schaller, Maik Schaufuß, Marcel Schlandt, Daniel Schmid, Patrik Schmidt, Eva Maria Schmidt, Johannes Schmitt, Joel Schmuck, Philip Schneider, Laura Schütz, Maximilian Schwindling, Florian Seufert, Menayl Shah, Iana Shcherbakova, Lotta Steger, Maximilian Steverding, Laura Stoib, Rafael Stutz, Prayudi Sudiarto, Jason Textor, Marcel Thielitz, Carina Thomas, Fletcher Tollefson, Julia Treichel, Julian Trummer, Mounika Vaddeboina, Arvand Vaghari Fard, Barbara Waarden, Katharina Wagner, Lavinia Wagner, Alexandra Weber, Simon Weiss-Eizinger, Mario Weissner, Vincent Wenk, Vera Wesinger, Felicia Wiehler, Frauke Wilken, Tobias Winkler, Martin Wintersteller, Carolin Wittmann, Bianca Woisetschläger, Kilian Wolf, Josef Wöfl, Lars Wüstemann Aronica, Xianbin Xie, Yinzhe Zhang, Daniel Zollitsch, Max Benjamin Zorn

Administration

Giovanna Bianchi, Kirstin Blaschke, Marlies Blasl, Anja Böckl, Jeannette Burgold, Lucia Celinkovic, Marga Cervinka, Karin Donko, Marion Feistner, Martine Felix, Martina Heinemann, Martha Hipp, Edeltraud Hirscheider, Maria Jovanovic, Elke Kabitzsch, Gabriele Klengenheben, Elisabeth Kronthaler, Katharina Kuchlmayr, Tanja Landmann, Catherine Lao, Evi Lemberger, Martin Luce, Cornelia Lutz-Mastrojanni, Christine Mädler, Rike Menacher, Susanne Nwabuodafi, Tanja Nyc, Susanne Oxe, Andrea Paul, Alexandra Petersdorff, Kerstin Roscher, Sieglinde Scheske, Rebekka Schlenker, Barbara Schnabel, Yolande Schneider, Thilo Schuster, Ketevan Sevsal, Elisabeth Sollinger-Fiuza, Angelika Uslu, Doris Walter, Hannah Wälzholz, Evelyn Wegner, Katharina Wenninger, Heike Wetzstein-Duesing, Olga Wiedenhöft, Ingrid Wolfrath, Gabriele Zechner

Technical Staff

Hans Birg, Andreas Bittner, Andreas Bohmann, Hendrik Brödenfeld, Rita Burkhardtsmaier, Anton Josef Heine, Arne-Kristian Hingst, Sandra Kerstin Kahl, Michael Leibl, Thomas Lohmaier, Isabel Mühlhaus, Matthias Müller, Jan Riepert, Klaus Scheuenpflug, Heike Schollmeyer, Bernhard Schöner, Stefan Sommer, Florian Treitl, Markus Uemminghaus, Ester Vletsos, Johann Weber



Preview: Review #3

Interview with Prof. Hannelore Deubzer,
Chair of Spatial Arts and Lighting Design

Imprint

TUM Department of Architecture
Office of the Dean
www.ar.tum.de
@architecture.tum

Conception

Martin Luce
Sophia Pritscher
Hanne Rung

Chief Editor/ Art Direction

Hanne Rung, Munich/ Berlin

Student Assistance

Lisa Bamberg

Translation/ Editing

Roxanne Powell, Vienna

Cover

Illustration: Lisa Bamberg, © TUM Department of
Architecture, after the graphic model of Völlm+Walthert,
Zurich for ETH Parity Talks

Graphic Design Template

ediundsepp Gestaltungsgesellschaft mbH, Munich

Print

Joh. WALCH GmbH & Co KG

Publisher

Technische Universität München
Fakultät für Architektur
Arcisstr. 21, 80333 München
www.ar.tum.de, verlag@ar.tum.de

ISBN 978-3-948278-02-1



Nominal charge
EUR 6.00