

**WISSENSCHAFTSZENTRUM WEIHENSTEPHAN FÜR ERNÄHRUNG,  
LANDNUTZUNG UND UMWELT**

**Modifying conventional harvesting heads: a technical  
approach to in-stand debarking under central  
European conditions**

Joachim Bernd Heppelmann

Vollständiger Abdruck der von der Fakultät  
Wissenschaftszentrum Weihenstephan für Ernährung, Landnutzung und Umwelt  
der Technischen Universität München zur Erlangung des akademischen Grades  
eines Doktors der Naturwissenschaften (Dr.rer.nat.) genehmigten Dissertation.

Vorsitzende/-r: Prof. Dr. Thomas Knoke

Prüfende/-r der Dissertation:

1. Prof. Dr. Eric R. Labelle
2. Prof. Dr. Stefan Wittkopf
3. Prof. Dr. Klaus Richter

Die Dissertation wurde am 01.10.2019 bei der Technischen Universität München  
eingereicht und durch die Fakultät Wissenschaftszentrum Weihenstephan für Ernährung,  
Landnutzung und Umwelt am 27.04.2020 angenommen

*A nation that destroys its soils destroys itself.  
Forests are the lungs of our land,  
purifying the air and giving fresh strength to our people.*

Franklin D. Roosevelt

## Acknowledgements

First of all, I want to thank everybody that was involved within the research project, adding their unique part to the great success of our debarking system. Therefore, I want to thank the Fachagentur für Nachwachsende Rohstoffe e.V. and the German Federal Ministry of Food and Agriculture for the trust and support, funding the research during the past four years. Further, I want to thank our project partner, the Kuratorium für Waldarbeit und Forsttechnik e.V., Prof. Seeling, Mr. Heinrich, Mr. Grünberger and Mrs. Hauck for the close and successful cooperation. I also want to thank Mr. Satzinger (John Deere), Mr. Dreeke (Wahlers Forsttechnik/Ponsse) and Mr. Peil (LogMax) for the great support by providing both hardware parts and important expertise. For providing forest stands and supporting the field trials, I want to specially thank Mr. Guba (Niedersächsische Landesforsten) and Dr. Windisch (Bayerische Staatsforsten). However, most importantly I want to thank Mr. Raker and Mr. Harrer for being open-minded and granting huge support by providing their machines and expertise. Together with the great operators Mr. Burlage, Mr. Steincke and Mr. Scholl, this was an important key to the success for the implementation of the debarking system and was appreciated at all time.

Besides the research project, I would like to take the chance to thank all my colleagues and friends that were involved over the last four years. I want to say thank you for every laugh, every talk or every recreational activity that was and is highly appreciated as it led me to this special point of my career.

For putting his trust in me and my skills, I want to thank Prof. Stefan Wittkopf. Thank you for granting me the opportunity to join the research project and for your trust in me to research your vision of debarking harvesting heads operated in central European forests. In the last four years, you submerged me inside in all aspects of the project management and organization with unconditional support throughout.

For an exceptional support over the last five years, I especially want to thank Prof. Eric R. Labelle! Thank you for being such a great supervisor and mentor over this long time. Every writing session, every meeting and the continuous support was highly appreciated at all time. Thank you especially for the encouragement and motivation during not so pleasant times! Every little thing was leading to this fine piece of work and to whom I am as a researcher today.

Most of all however, I want to thank my family! Thank you for all the unconditional support and love throughout. Therefore, I want to dedicate this work to the two people that supported me from the first day on:

- My parents -

## Abstract

Central European forests are increasingly confronted with biotic and abiotic challenges that appear in correlation with the latest climate change. Exploitation of nutrient poor soils via intensified utilization of forest biomass, spreading bark beetle infestations, trees in distress by draughts and tense logistic schedules due to poor availability of cargo space, are only few among other challenges. Taken together, these factors have a great influence and intensify the pressure on current forest ecosystems. To tackle several of these challenges and provide a potential tool for future wood procurement decisions, a comprehensive study was performed to reintroduce in-stand debarking to modern harvesting operations in central European conditions.

Within seven field trials, three different conventional harvesting heads were modified with parts originally designed for Eucalyptus debarking heads in order to add debarking as part of the fully mechanized harvesting procedure. The prototypes were tested in Norway spruce (*Picea abies*) and Scots pine (*Pinus sylvestris*) cut-to-length harvesting operations in Bavaria and Lower Saxony, Germany. Those trials were further divided into summer and winter tests to assess the influence of harvesting season and associated sap flow on debarking efficiency. Due to the predominant situation regarding spruce bark beetle infestations, the summer tests in Bavaria were conducted within spruce bark beetle treatments.

The evaluation of the debarking percentage from live forest operations was completed with a measurement software developed within the project. The newly

developed software named Stemsurf was based on a single photo-optical picture recoding the broad-side of a single log. In a second step, the recorded images were evaluated within the software by applying polygons to the bark remnants and calculating the surface shares (bark (phellem/phloem), wood, covered/not measurable) according to the entire stem surface. In total, 1720 logs were recorded and evaluated to determine the debarking percentage originating from the carried out harvesting head modifications. The Stemsurf software was further tested under laboratory conditions with known debarking patterns to assess the precision and bias and therefore possible deviations within the field applications. As the in-stand debarking process raised multiple concerns, communicated by truck drivers and logistic entrepreneurs, the influence of the harvester-based debarking on load safety was investigated as a final step.

During the laboratory tests, the Stemsurf application proved to be reliable and delivered robust results with a standard deviation below the anticipated 5% and an average positive bias of 6.7%. Within the field trials, Stemsurf detected debarking percentages of 73–91% for summer applications of the modified harvesting heads. With debarking results varying between 35–57%, performance of the winter tests was lowered by 46% compared to summer operations. Factors such as the stem diameter and position of an assortment within the tree proved to have a negative influence on the debarking result of up to 15% as well.

Besides field application tests with modified harvesting heads, static and sliding frictions of debarked logs were proven to be significantly lower within the cargo security test, compared to bark logs within the first week after harvesting. This effect was no longer present after a drying period of seven days according to the weather conditions present during testing. Furthermore, debarked logs showed an 45% faster drying rate in comparison to barked logs and therefore potential benefits

on the cargo load through a higher potential load volume with decreased total cargo mass. In conclusion, conventional head modifications were feasible and offered the possibility to debark logs directly in the stand within fully mechanized harvesting operations, which acted beneficially on the nutrient supply, bark beetle infestation control and logistic challenges.

Keywords: fully mechanized harvesting, debarking harvesting head, photo-optical measurement systems, static and sliding frictions, debarked roundwood, in-stand debarking

## Zusammenfassung

Mitteuropäische Wälder sind zunehmend biotischen und abiotischen Einflussfaktoren ausgesetzt, welche unter anderem im direkten Zusammenhang mit dem jüngsten Klimawandel stehen. Die verstärkte Nutzung von Biomasse auf nährstoffschwachen Standorten, Bestände im Trockenstress, die anhaltende Ausbreitung des Borkenkäfers und die dadurch angespannte Lage innerhalb der Logistik, auch aufgrund der schlechten Verfügbarkeit von Frachtkapazitäten, sind hierbei nur einige der Herausforderungen innerhalb der modernen Forstwirtschaft. Zusammengenommen können sich diese Faktoren multiplizieren und den Druck auf die Waldökosysteme weiter verstärken. Auf Grund dessen wurde eine umfassende Studie durchgeführt, um die technischen Möglichkeiten einer modernisierten Entrindung direkt im Bestand auf die genannten Spannungsfelder abschätzen zu können.

In diesem Projekt wurden daher drei unterschiedliche konventionelle Harvesterfällköpfe mit Anbauteilen modifiziert, welche ursprünglich für die Eukalyptusernte konzipiert worden sind. Die so entstandenen Prototypen wurden in sieben Feldversuchen in Ernteeinsätzen von Fichte (*Picea abies*) und Kiefer (*Pinus sylvestris*) in Bayern sowie Niedersachsen (Deutschland) getestet und untersucht. Die Versuchseinsätze wurden sowohl im Sommer als auch im Winter durchgeführt, um den Einfluss der Vegetationszeit und des damit verbundenen Saftflusses im Stamm auf das Entrindungsergebnis zu erfassen. Aufgrund der verheerenden Befalls-Situation durch Borkenkäfer in Bayern wurden die entsprechenden Sommersversuche in befallenen Beständen durchgeführt, und das System erstmals

für die Käferbekämpfung getestet. Die Bewertung der im Versuch erreichten Entrindungsergebnisse wurde mit einer eigens hierfür im Projekt entwickelten Software durchgeführt. Für diese Bewertung benötigte die Software (Stemsurf) ausschließlich eine photo-optische Abbildung der Stammoberfläche. Anschließend wurden die aufgenommenen Bilder innerhalb der Software in entsprechende Polygone (Rinde (Bast/Borke), Holz, verdeckt/nicht messbar) untergliedert, und die Oberflächenanteile berechnet. Insgesamt wurden 1720 Stammabschnitte erfasst, und das Entrindungsprozent, resultierend aus den durchgeführten Modifikationen, ermittelt. Des Weiteren wurde die Stemsurf-Software einer Testreihe unter Laborbedingungen unterzogen, um die Präzision und damit mögliche Abweichungen innerhalb der Versuchsanwendungen bewerten zu können. Da innerhalb des Projektes wiederkehrend Sicherheitsbedenken bezüglich des Transportes von entrindeten Sortimenten geäußert wurden, bedurfte der Einfluss der Entrindung auf Ladungssicherheit, mit der Überprüfung relevanter Parameter ebenfalls der Untersuchung.

Die Stemsurf-Software erwies sich während der Laborversuche als zuverlässig und lieferte robuste Ergebnisse mit einer Standardabweichung unterhalb der erwarteten 5% und einer durchschnittlichen positiven Verzerrung von 6,7% auf das Entrindungsergebnis. Innerhalb der Sommer-Feldversuche wurden mittels Stemsurf durchschnittliche Entrindungsprozente von 73–91% gemessen. Mit einem durchschnittlichen Entrindungsprozent von 35–57%, zeigten Versuche innerhalb der Wintermonate ein um 46% geringeres Entrindungsergebnis. Einflussfaktoren wie der Stammdurchmesser und die Position einer Fixlänge innerhalb des Stammes wirkten sich ebenfalls durch ein bis zu 15% geringeres Entrindungsergebnis negativ aus. Innerhalb der Reibwertversuche zur Ladungssicherheit entrindeter Sortimente zeigten entrindete Stammabschnitte signifikant geringere Haft- und Gleitreibwerte



im Vergleich zu unentrindeten Sortimenten. Dieser Effekt war jedoch nach einer Trocknungszeit von sieben Tagen unter den vorherrschenden Wetterbedingungen innerhalb des Prüfzeitraumes nicht mehr nachweisbar. Darüber hinaus konnte für entrindete Stämme eine um 45% schnellere Trocknungsrate nachgewiesen werden, was sich positiv auf Berechnungen von Gesamtladevolumen und Gesamtladungsmasse auswirkte. Zusammenfassend lässt sich sagen, dass Modifikationen von konventionellen Harvesterfällköpfen zu Entrindungszwecken schon mit geringem Aufwand durchführbar sind und sich die Entrindung direkt im Bestand nachweislich positiv auf die Nährstoffversorgung, die Aufarbeitung von befallenem Käferholz und die Holz-Logistikkette auswirken kann.

Schlagworte: voll mechanisierte Holzernte, entrindende Harvesterfällköpfe, photo-optische Messsysteme, Haftreibung, Gleitreibung, entrindetes Rundholz, Entrindung im Bestand

## Table of Contents

Acknowledgements.....	II
Abstract.....	III
Zusammenfassung .....	VI
Table of Contents.....	IX
List of Figures.....	XIII
List of Tables .....	XVI
Abbreviations.....	XVIII
<b>I. Cumulative Thesis .....</b>	<b>XIX</b>
1. Publications.....	XX
1.1. Peer-reviewed publications within the PhD project .....	XX
1.2. Further peer-reviewed publications and conference contributions ...	XX
2. Papers at a glance.....	XXI
3. Summary and author contributions.....	XXII
3.1. Heppelmann et al. 2019a .....	XXII
3.2. Heppelmann et al. 2019b.....	XXIII
3.3. Heppelmann et al. 2019c .....	XXIV

<b>II. Thesis</b> .....	1
1. Introduction.....	2
1.1. History of in-stand debarking and debarking harvesting heads .....	3
1.2. Benefits of in-stand debarking.....	5
1.3. Knowledge gap and research objectives.....	7
1.4. Study approach .....	8
1.5. Content and structure of the thesis .....	10
2. Materials and Methods.....	11
2.1. Selection, modification and testing of conventional harvesting heads .....	11
2.2. Stand selection and characteristics .....	19
2.3. Stemsurf.....	22
2.3.1. Stemsurf - general functions.....	22
2.3.2. Stemsurf - accuracy validation .....	23
2.3.3. Stemsurf - field applications.....	24
2.4. Load safety test setup and measurements.....	26
3. Main Results .....	29
3.1. Precision and bias evaluated under laboratory conditions .....	29
3.1.1. Precision evaluation.....	29
3.1.2. Bias evaluation .....	30
3.2. Effect of machine type and season on debarking efficiency .....	32
3.3. Effect of log diameter, species and season on debarking efficiency ...	35

3.4.	Effect of log positioning in tree, species and season on debarking efficiency.....	36
3.5.	Development of static and sliding frictions single test wise comparison.....	38
3.5.1.	Static friction .....	39
3.5.2.	Sliding friction.....	40
3.6.	Influence of debarking treatment on load volume and mass .....	41
4.	Discussion.....	44
4.1.	Debarking head modifications.....	44
4.1.1.	General modifications .....	44
4.1.2.	Feed rollers .....	45
4.1.3.	Delimiting knives.....	47
4.1.4.	Measuring wheel .....	48
4.1.5.	Productivity .....	49
4.2.	Stemsurf.....	50
4.3.	Positive effects of in-stand debarking .....	53
4.3.1.	Effects on the nutrient supply of forest ecosystems originating from in-stand debarking harvesting operations .....	53
4.3.2.	Influences on the spruce bark beetle population through debarking of infested trees .....	54
4.3.3.	Effects on cargo load and load safety of debarked logs .....	56
5.	Study limitations and areas of improvements.....	59

6. Conclusions.....	62
7. Additional experiences gained through the PhD project .....	64
7.1. Project management and field test organization.....	64
7.2. Measurements and digitalization .....	66
7.3. Dissemination of knowledge .....	72
7.4. Supervision experiences .....	73
References.....	75
<b>III. Appendices .....</b>	<b>80</b>
Appendix I .....	81
Appendix II.....	82
Appendix III.....	99
Appendix IV .....	115

## List of Figures

Figure 1: Debarking of Eucalyptus spec. trees in South Africa.....	3
Figure 2: Timeline of major developments in the field of log debarking, completed with the main techniques utilized within the German forestry sector.....	4
Figure 3: Content and structure of the thesis including the source of information.....	10
Figure 4: Debarking and modifiable harvesting heads available on the market, with the maximum and optimum operation spectrum.....	12
Figure 5: Technical specifications of the three modified harvesting heads .....	15
Figure 6: Different traction types of feed rollers .....	16
Figure 7: Modified harvesting head prototypes .....	17
Figure 8: Modifications performed on the three different harvesting head prototypes .....	18
Figure 9: The S3 Setup in the Summer trial (Bavaria) on the third pass, cutting the stem into assortments after delimiting and debarking.....	19
Figure 10: Test sites located within Germany .....	20
Figure 11: Schematic chart of the operating principle and working steps for the Stemsurf software.....	23

Figure 12: A) Forwarding and arranging the debarked spruce logs on the forest road for debarking result measurements; B) Setup of debarked pine logs for the evaluation of the debarking percentage, picture Nr. 1 .....	25
Figure 13: Top view of the test setup containing 100 test logs (1.0 m in length) lying on a row of support logs (1.5 m in length), divided into four different treatments .....	26
Figure 14: Schematic display of the static and sliding friction measuring unit setup .....	27
Figure 15: Overview of all measured debarking percentages and significant differences within the different field tests.....	33
Figure 16: Overview of the measured debarking percentages and significant differences by 5-cm log diameter categories and species/season .....	36
Figure 17: Overview of the measured debarking percentages and significant differences by vertical position of the log within the tree and species/season .....	37
Figure 18: Schematic display of (A) self-loading combined truck with short wood trailer providing a lorry length of 2.0 × 5.1 m and lorry width of 2.27 m and (B) self-loading truck with long trailer and a lorry length of 13.0 m and lorry width of 2.4 m .....	41
Figure 19: Schematic of a 2D projection of a log via equal pixels and the expected described log surface .....	52
Figure 20: Recorded predator-pray relationship of feeding wasps on spruce bark beetle larvae after debarking during the S2 summer tests.....	56

Figure 21: Relations of the involved parties within each field-test of debarking harvesting modifications ..... 65

Figure 22: Measurement setup of a Trimble V10, connected to total station during the S1 Summer trials ..... 67

Figure 23: Measurement setup of the Faro Focus3D terrestrial laser scanner during the S2 summer trials ..... 68

Figure 24: 3D laser scans of logs within the PhD project ..... 69

Figure 25: In field test applications of a Faro Freestyle3D laser scanner to record debarked Scots pine logs ..... 70

Figure 26: Footage recorded by a drone during the S1 summer field trials ..... 71

Figure 27: Thermal images of debarked Norway spruce logs directly after processing ..... 72



## List of Tables

Table 1: Overview of the 31 available debarking and modifiable harvesting heads, presented with the hardware characteristics.....	13
Table 2: Harvesters and harvesting heads studied .....	14
Table 3: Basic stand characteristics presented by operation.....	21
Table 4: Descriptive statistics presenting the main results comparing the calculated average debarking percentages .....	30
Table 5: Descriptive statistics of the calculated average debarking percentages.....	31
Table 6: Measured average debarking percentages obtained from field applications and corrected based on findings of the laboratory accuracy validation .....	34
Table 7: Mass reduction of the test logs within the friction test setup after 7 and 21 days .....	38
Table 8: Average static frictions of test sessions 1, 12, and 13 as well as minimum, maximum, and overall average .....	39
Table 9: Average sliding frictions of test sessions 1, 12 and 13 as well as minimum, maximum, and overall average .....	40
Table 10: Machine-related characteristics and dimensions considered within the loading and mass capacity calculations .....	42

Table 11: Calculated differences between debarked and bark assortments concerning additional load and total mass of the loaded truck and trailer combination, after certain drying periods .....	43
Table 12: List of further presentations and knowledge transfer activities .....	73
Table 13: List of bachelor level theses co-supervised by the PhD Candidate .....	74

## Abbreviations

CO <sub>2</sub>	- Carbon Dioxide
KWF	- Kuratorium für Waldarbeit und Forsttechnik e.V.
S1	- Setup 1
S2	- Setup 2
S3	- Setup3
DWD	- German Meteorological Service
DBH	- Diameter at breast height
n	- Sample size
VDI	- Verein Deutscher Ingenieure
N	- Newton
Hz	- Hertz
E(Θ)	- estimates of parameters
θ	- true parameter
B	- Butt log
M <sub>x</sub>	- Mid log
t	- Top log
LiDAR	- Light detection and ranging
RGB	- Red, Green and Blue values

# I. Cumulative Thesis

This dissertation is based on investigations contained in the following three original peer-reviewed articles.

## 1. Publications

### *1.1. Peer-reviewed publications within the PhD project*

**Heppelmann, J.B.**, Labelle, E.R., Seifert, T., Seifert, S. and Wittkopf, S., 2019. Development and Validation of a Photo-Based Measurement System to Calculate the Debarking Percentages of Processed Logs. *Remote Sensing*, 11(9), p.1133.

**Heppelmann, J.B.**, Labelle, E.R., Wittkopf, S. and Seeling, U., 2019. In-stand Debarking with the Use of Modified Harvesting Heads: a potential Solution for Key Challenges in European Forestry. *European Journal of Forest Research*. 15 pp. doi.org/10.1007/s10342-019-01225-y

**Heppelmann, J.B.**, Labelle, E.R. and Wittkopf, S., 2019. Static and Sliding Frictions of Roundwood Exposed to Different Levels of Processing and Their Impact on Transportation Logistics. *Forests*, 10(7), p.568.

### *1.2. Further peer-reviewed publications and conference contributions*

Labelle, E., **Heppelmann, J.** and Borchert, H., 2018. Application of Terrestrial Laser Scanner to Evaluate the Influence of Root Collar Geometry on Stump Height after Mechanized Forest Operations. *Forests*, 9(11), p.709.

**Heppelmann, J.B.**; Labelle, E.R.; Seeling, U.; Wittkopf, S., 2018. Debarking Heads, a potential solution to modern forestry challenges in Europe? 51<sup>st</sup> International Symposium on Forestry Mechanization (FORMEC), Spain.

**Heppelmann, J.B.**; Labelle, E.R.; Seeling, U.; Wittkopf, S., 2016. Evaluating the debarking efficiency of modified harvesting heads on European tree species. 49<sup>th</sup> International Symposium on Forestry Mechanization (FORMEC), Poland.

**Heppelmann, J.B.**; Labelle, E.R.; Windisch, J.; Gloning, P.; Borchert, H.; Schulmeyer, F., 2015. Evaluating the influence of root collar on stump height following mechanized forest operations. 48<sup>th</sup> International Symposium on Forestry Mechanization (FORMEC), Austria.

## 2. Papers at a glance

Paper	Reference	Research objectives	Material and Methods	Main findings
I	<b>Heppelmann, J. B.</b> , Labelle, E. R., Seifert, T., Seifert, S., Wittkopf, S. (2019). Development and validation of a photo-based measurement system to calculate the debarking percentages of processed logs. <i>Remote Sensing</i> , 11(9), 1133.	Develop and assess the performance of a photo-optical measurement system designed to quantify the debarking percentage of processed logs.	A computer-based photo-optical measurement system (Stemsurf) was developed to assess the debarking percentage recorded in the field. The software was tested under laboratory conditions and applied in live field operations. To assess the precision and bias of the developed measurement system, 480 images were recorded under laboratory conditions using an artificial log with defined surface polygons. In total, 1720 logs of coniferous species were debarked by modified harvesting heads and analyzed within Stemsurf.	Results of the laboratory precision evaluation showed that the standard deviation of average debarking percentages remained within a 4% variation. A positive bias of 6.7% was caused by distortion and perspective effects. This resulted in an average underestimation of 1.1% for the summer debarking percentages gathered from field operations.
II	<b>Heppelmann, J. B.</b> , Labelle, E. R., Wittkopf, S., Seeling, U. (2019). In-stand debarking with the use of modified harvesting heads: a potential solution for key challenges in European forestry. <i>European Journal of Forest Research</i> , 15pp.	Determine required types of technical modifications and operational procedures needed, to adapt conventional harvesting heads and provide them with debarking ability. Perform field tests to evaluate and quantify the debarking percentage achieved and obtain a general overview of harvesting productivity between conventional and modified harvesting heads.	Debarking rollers and parts designed for Eucalyptus harvesting heads were tested on conventional harvesting heads for the first time to assess the possibility of adding debarking to mechanized harvesting operations under central European conditions. Seven field tests with varying tree species, diameters and age classes, were established in both summer and winter seasons to evaluate the influence of associated tree sap flows on the debarking quality. To assess the different mechanical characteristics and setups, three different harvesting heads were modified.	Results demonstrate that, especially for summertime operations, simple harvesting head modifications provided an average debarking efficiency up to 90%. Another key finding is that a negatively affected sap flow, experienced during wintertime operations, resulted in a 46% lower debarking efficiency. Additionally, the vertical position of the log within the tree proved to have an influence on debarking efficiency, resulting in 15% lower average debarking for butt logs and 9% for top logs as compared to middle logs.
III	<b>Heppelmann, J. B.</b> , Labelle, E. R., Wittkopf, S. (2019). Static and sliding frictions of roundwood exposed to different levels of processing and their impact on transportation logistics. <i>Forests</i> , 10(7), 568.	Quantify differences in static and sliding frictions within four treatments to understand how the frictions fluctuated over time and if this results in significant influence on the differences between treatments and how to debarked roundwood should be transported safely.	To assess the influence of debarking logs onto the static and sliding frictions of Norway spruce, pulling tests were performed and compared to barked assortments. The frictions were further linked to the mass reduction and drying rate caused by the debarking process and the associated transport capacities of debarked logs with common truck and trailer configurations.	Results showed that a significant difference in both static and sliding frictions existed between barked and debarked assortments within the first seven days after harvesting. The significant difference decreased after the logs continued to dry out. Furthermore, the debarked assortments presented a 40 to 45% faster drying rate as compared to barked assortments. This resulted in a calculated 11 to 28% additional transportable net load [m <sup>3</sup> ] of debarked roundwood assortments for long trailer systems.

### 3. Summary and author contributions

#### 3.1. Heppelmann et al. 2019a

Heppelmann, J. B., Labelle, E. R., Seifert, T., Seifert, S., Wittkopf, S. (2019a). Development and validation of a photo-based measurement system to calculate the debarking percentages of processed logs. *Remote Sensing*, 11(9), 1133.

**Journal Impact Factor: 4.118**

#### **Summary**

To assess debarking percentages originating from modifications made to conventional harvesting heads, a suitable measurement system was required to record the debarking percentages. Because data acquisition needed to be performed directly during live forest operations, a computer-based photo-optical measurement system (Stemsurf) was developed. The software was tested under laboratory conditions and also applied within live field operations. To further assess the precision and bias of the developed measurement system, 480 images were recorded under laboratory conditions using an artificial log with defined surface polygons. In total, 1720 logs of coniferous species were debarked by modified harvesting heads and analyzed within Stemsurf. Results of the laboratory precision evaluation showed that the standard deviation of average debarking percentages remained within a 4% variation. A positive bias of 6.7% was caused by distortion and perspective effects. This resulted in an average underestimation of 1.1% for the summer debarking percentages gathered from field operations.

#### **Author contributions**

Joachim B. Heppelmann conceived and designed the methodology and carried out both laboratory and field sampling under the supervision of Prof. Labelle. Joachim B. Heppelmann conducted all statistical calculations and assessed both precision and bias. Stemsurf was programmed by Prof. Thomas Seifert and Dr. Stefan Seifert and the part regarding the programming algorithm was provided to the manuscript accordingly. The manuscript was written by Joachim B. Heppelmann and Prof. Labelle. Other listed authors contributed to the manuscript with insightful comments and revisions.

### *3.2. Heppelmann et al. 2019b*

Heppelmann, J. B., Labelle, E. R., Wittkopf, S., Seeling, U. (2019b). In-stand debarking with the use of modified harvesting heads: a potential solution for Key challenges in European forestry. *European Journal of Forest Research*, 15 pp.

**Journal Impact Factor: 2.354**

#### **Summary**

Within the basic research project of debarking harvesting heads, the required technical modifications and operational procedures to adapt conventional harvesting heads and provide them with debarking ability were determined. Therefore, field tests were performed to evaluate and quantify the achieved debarking percentage and to obtain a general overview of harvesting productivity between conventional and modified harvesting heads. Debarking rollers and parts designed for Eucalyptus harvesting heads were hence tested on conventional harvesting heads for the first time to assess the possibility of adding debarking to mechanized harvesting operations under central European conditions. Seven field tests with varying tree species, diameters and age classes, were established in both summer and winter seasons to evaluate the influence of associated tree sap flows on the debarking quality. To assess the different mechanical characteristics and setups, three different harvesting heads were modified. The results demonstrated that especially for summertime operations, simple harvesting head modifications provided an average debarking efficiency up to 90%. Another key finding was that a negatively affected sap flow, experienced during wintertime operations, resulted in a 46% lower debarking efficiency. Additionally, the vertical position of the log within the tree had an influence on debarking efficiency, resulting in 15% lower average debarking for butt logs and 9% for top logs as compared to middle logs.

#### **Author contributions**

The methodology was conceived, designed and carried out by Joachim B. Heppelmann under the supervision of Prof. Labelle. Further, all calculations and evaluations were conducted by Joachim B. Heppelmann in coordination with Prof. Labelle. The resulting manuscript was written by Joachim B. Heppelmann and Prof. Labelle. Prof. Ute Seeling provided information on the harvester productivity gathered by the KWF. Prof. Stefan Wittkopf was project leader. Both Profs. Seeling and Wittkopf also contributed to the manuscript by providing comments and revisions.



### 3.3. Heppelmann et al. 2019c

Heppelmann, J. B., Labelle, E. R., Wittkopf, S. (2019c). Static and sliding frictions of roundwood exposed to different levels of processing and their impact on transportation logistics. *Forests*, 10(7), 568.

**Journal Impact Factor: 2.116**

#### **Summary**

To quantify the influence of the debarking process on the cargo security of debarked logs, differences in static and sliding frictions within four treatments were carried out, to understand i) how the frictions fluctuated over time, ii) if this resulted in significant influence on the differences between treatments and iii) how debarked roundwood should be transported safely. Multiple pulling tests were performed and compared to barked assortments, to assess the influence of debarking logs onto the static and sliding frictions of Norway spruce. The frictions were further linked to the mass reduction and drying rate caused by the debarking process and the associated transport capacities of debarked logs with common truck and trailer configurations. Results showed that a significant difference in both static and sliding frictions existed between barked and debarked assortments within the first seven days after harvesting. The significant difference decreased after the logs continued to dry out. Furthermore, the debarked assortments presented a 40 to 45% faster drying rate as compared to barked assortments. This resulted in a calculated 11 to 28% additional transportable net load [m<sup>3</sup>] of debarked roundwood assortments for long trailer systems.

#### **Author contributions**

Friction tests published in the manuscript were conceived, designed, carried out and evaluated by Joachim B. Heppelmann under the supervision of Prof. Labelle. The manuscript was written by Joachim B. Heppelmann in cooperation with Prof. Labelle. Prof. Stefan Wittkopf contributed to the manuscript with thoughtful advice and revisions.

## II. Thesis

Modifying conventional harvesting heads: a  
technical approach to in-stand debarking  
under central European conditions

## 1. Introduction

Forest are one of the most important resource for the survival and well-being of humankind. The latter is particularly true for rural and less developed countryside all over the world. A growing population density will further result in an increasing demand for wood und wood-based products. This demand is currently supplied by 30.9% (39.9 million km<sup>2</sup>) of the earths land area that is covered with forestland (Payn et al. 2015) and hence more and more threatened by over exploitation.

Due to the strain applied to forests ecosystems, plantation forests became an important supplier to fulfil the growing need for wood as a source of material and energy (Quartucci 2015; Sedjo 2019). Nowadays, plantation forests throughout the world (Australia; Brazil; China; New Zealand; South Africa; etc.) are highly mechanized production units often targeting fast growing tree species such as Eucalyptus (Pohjonen and Pukkala 1990; Turnbull 1999). However, due to the high growth rates and associated short rotation cycles of the planted trees, nutrient depletion resulting from frequent harvests are leading to visible and measurable growth impediments. According to Rocha et al. (2016), the removal of all forest residues resulted in a 40% decreased productivity within the following two short rotations of a Eucalyptus plantation. This highlights the necessity of leaving harvesting residues, such as bark, within the forest stand to maintain the soil fertility and associated productivity.

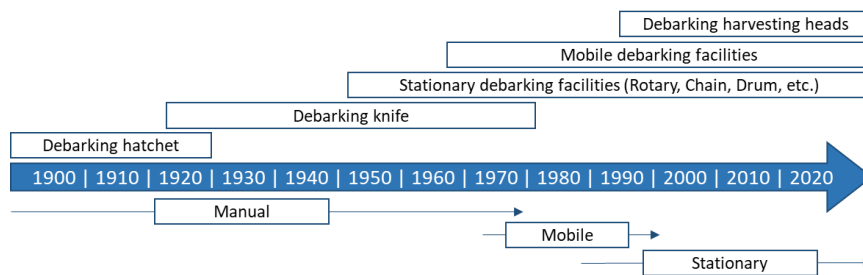
### *1.1. History of in-stand debarking and debarking harvesting heads*

In South Africa, debarking in plantation forests was performed for a long time with rather primitive tools such as axes and debarking knives. Within the last decades, debarking procedures improved from manual to mobile debarking machines and finally to fully mechanized harvesters equipped with debarking heads (Eggers 2010). Harvester-based debarking is currently an important segment of the wood procurement process and is performed directly in the forest stand during fully mechanized harvesting operations (Figure 1). Purposely-designed harvesting heads were developed to shear off the bark through a combination of special knives and feed rollers. Moreover, modifications to the chassis of the harvesting head were targeted to strengthen the overall structure and absorb the occurring shear forces. This in-stand debarking is mandatory for tree species such as Eucalyptus, because the bark has to be removed shortly after felling, otherwise the inner bark will dry out and stick tightly onto the wooden body. Debarking at a later stage will entail high mechanical effort (Labelle et al. 2019). To achieve an optimal debarking result, the trunk of a felled tree is fed in its complete length multiple times through the debarking harvesting head, thus reducing the productivity of the harvesting operations (Magagnotti et al. 2011; van der Merwe et al. 2016).



**Figure 1:** Debarking of Eucalyptus spec. trees in South Africa (© Wittkopf 2013)

In comparison to the developments within tropical and subtropical Eucalyptus plantations, debarking of harvested logs also used to be an important part of central European wood procurement. However, starting in the late 1970s, a shift also occurred from manual in-stand debarking to stationary facilities (Figure 2). In contradiction to South Africa, the debarking process developed out of the forest and into wood processing facilities. Instead of leaving the bark along with its inherent high nutrient content in the forest, it is being transported to industrial facilities. The bark is then substituted in other channels such as fuel for heating plants / cogenerated facilities or bark mulch for gardening in order to create additional value instead of raising costs for waste disposal (Kupferschmid 2001; Baroth 2005; Gerasimov and Karjalainen 2006).



**Figure 2:** Timeline of major developments in the field of log debarking, completed with the main techniques (manual, mobile and stationary) utilized within the German forestry sector

### *1.2. Benefits of in-stand debarking*

In 2014, a basic research project was initiated to test in-stand debarking within central European mechanized harvesting operations. Therefore, debarking was planned to be added to conventional cut-to-length (CTL) single-tree treatments of typical European tree species such as Norway spruce and Scots pine. Mechanized harvesting was targeted since more than 60% of the current wood procurement on Bavarian public forests is carried out through fully mechanized harvesting operations (BaySF 2017). Therefore, a modification of the current CTL process, inspired from South African fully mechanized harvesting operations, seemed feasible.

Harvester-based in-stand debarking was further expected to provide several benefits in accordance with the experiences of plantation applications that could also address current European forestry challenges, such as nutrient depletion of forest soils through intensified utilization of forest biomass. By debarking processed logs directly in the forest stands, stored nutrients of the bark are remaining in close proximity to the felled tree and can therefore be absorbed by the surrounding vegetation and regeneration (Hopmans et al. 1993; Weis and Göttlein 2012; Nieminen et al. 2016; Yan et al. 2017). The removal of bark-bound nutrients through in-stand debarking, can also have a beneficial effect on the thermal use of wood, as bark and associated nutrients can be directly linked to the quantity of ash remnants in firing plants and fine dust outtake (Lehtikangas 2001; Werkelin et al. 2005; Kaltschmitt et al. 2009; Filbakk 2011).

During the testing phase of the debarking project, an urgent challenge of modern forestry appeared into the focus of the study - the current spreading infestations of spruce bark beetles (*Ips typographus*) throughout central Europe

(Carrol et al. 2017; Hinze et al. 2017; De Groot et al. 2019). The potential of modified harvesting heads with debarking ability to exterminate the early development stages of the spruce bark beetles by drying out the larvae and eliminating the threat of harvested logs as subsequent breeding habitat, became the main driving factor of late stage research and early stage market implementation. Currently, over 30 modified harvesting heads, based on the investigated prototypes of the presented study, are operating within spruce bark beetle infested stands in Germany, Austria, Czech Republic and Switzerland (Hauck and Prüm 2019). The utilization of debarking harvesting head modifications is hereby expected to not only lower the risk of spreading spruce bark beetle infestations, but also lower the frequency at which insecticides are required to control spreading infestations, while expanding the appropriate time schedule of the logistic chain. The latter is caused by a direct link to the elimination effect of debarking on the threat of developing and emerging beetles out of the infested logs following a harvest. This occurs because debarked wood is no longer suitable as a breeding habitat for beetles and thus cannot be populated by a second generation of spruce bark beetles. Ultimately, this means that debarked material from spruce bark beetle infestations can remain in the forest for a longer period (Thorn et al. 2016).

Through the removal of the bark and subsequent higher drying rate of debarked logs, further important potential economic and ecological benefits linked to mass reductions were expected with in-stand debarking (Korten and Eberhardinger 2008a; Sohns 2012). Lowered mass of logs could result in either a reduced total load mass during road transportation or in an increased volume. Regardless of the approach chosen, a decrease in wear off and fuel consumption of timber transporting equipment as well as a reduction in CO<sub>2</sub> emissions per cubic meter of transported wood is to be anticipated.

### *1.3. Knowledge gap and research objectives*

Due to a lack of availability of fully mechanized in-stand debarking techniques for European harvesting operations (large diameters, complex tree architecture, larger diameter branches, etc.) the possibility of transferring the debarking technique of the tree farms into central European forests was sought. To make the system easily adaptable to conventional mechanized operations, modifications and field trials of conventional harvesting heads and harvesting procedures were investigated. Furthermore, very limited research on the application of debarking harvesting heads and the influence on above-listed benefits had been published so far. Therefore, the main research objectives can be listed as:

- Determine which type of technical modifications and operational procedures are required to adapt conventional harvesting heads and provide them with debarking ability
- Perform field tests to evaluate and quantify the debarking percentage achieved with different modification setups being operated on spruce and pine trees during both summer and winter seasons
- Develop a photo-optical measurement system designed to quantify the debarking percentage of processed logs and to assess its performance under laboratory and field conditions



- Quantify differences in static and sliding frictions within four treatments (bark roundwood, debarked roundwood, mixed assortments, and debarked roundwood exposed to simulated consecutive heavy rainfall (watered) to gain a better understanding of load security
- Understand how the frictions fluctuated over time and if this had a significant influence on the differences between treatments. Particular attention was therefore given to drying rate, mass of logs, and whether the presence of water on the debarked log surface had a significant influence

Overall, comprehensive data should be gathered and presented to offer arguments for a potential market implementation of debarking harvesting head modification kits for the central European forestry sector.

#### *1.4. Study approach*

Harvesting head modifications were tested on 1720 logs of Norway spruce (*Picea abies* L. H. Karst) and Scots pine (*Pinus sylvestris* L.). To limit potential future investment costs, but also to add debarking as part of the European wood procurement, conventionally used harvesting heads were modified with existing mechanical parts of harvesting heads, originally designed to debark Eucalyptus in plantation operations. Modifications of the harvesting heads were carried out in close cooperation with well-established manufacturing and retail companies for fully mechanized harvesting equipment on the German market: John Deere, LogMax and Ponsse.

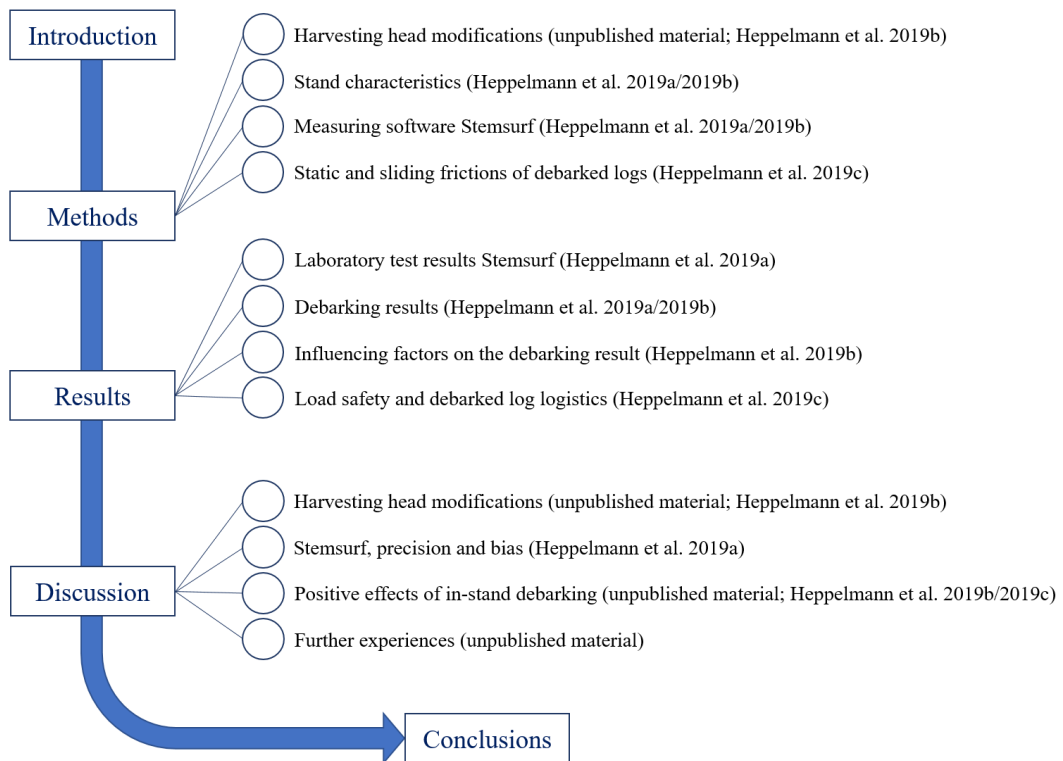
The resulting debarking percentages were evaluated directly in the field, with a measurement software that was therefore newly developed within the project. The measurement software called Stemsurf was further tested under laboratory conditions to assess the precision and bias.

In a third step, it was investigated if debarking had a positive influence on cargo load, through an increased transportable load volume, while decreasing total load mass. Furthermore, due to the rather soapy surface of freshly debarked logs, involved parties in the wood logistic chain communicated their concerns about the load safety on multiple occasions within the project. Therefore, a study was carried out to assess the influence of debarking on load safety of debarked logs by measuring the static and sliding frictions via standardized pulling tests.

All investigations pertaining to the debarking percentage were performed to evaluate the performance of harvesting head prototypes and thus potentially allow the reintroduction of in-stand debarking as part of the central European forestry portfolio.

### 1.5. Content and structure of the thesis

For clarity and to illustrate the flow of the thesis, a schematic structure is provided in Figure 3. Within the thesis, sections that contain published information are conceptualized as a comprehensive summary of the published facts, findings and discussion. Further information on those sections are provided within the scientific articles presented in the appendices. Sections of the thesis that contain unpublished material are elaborated to provide additional information relevant for a broader understanding of the project.

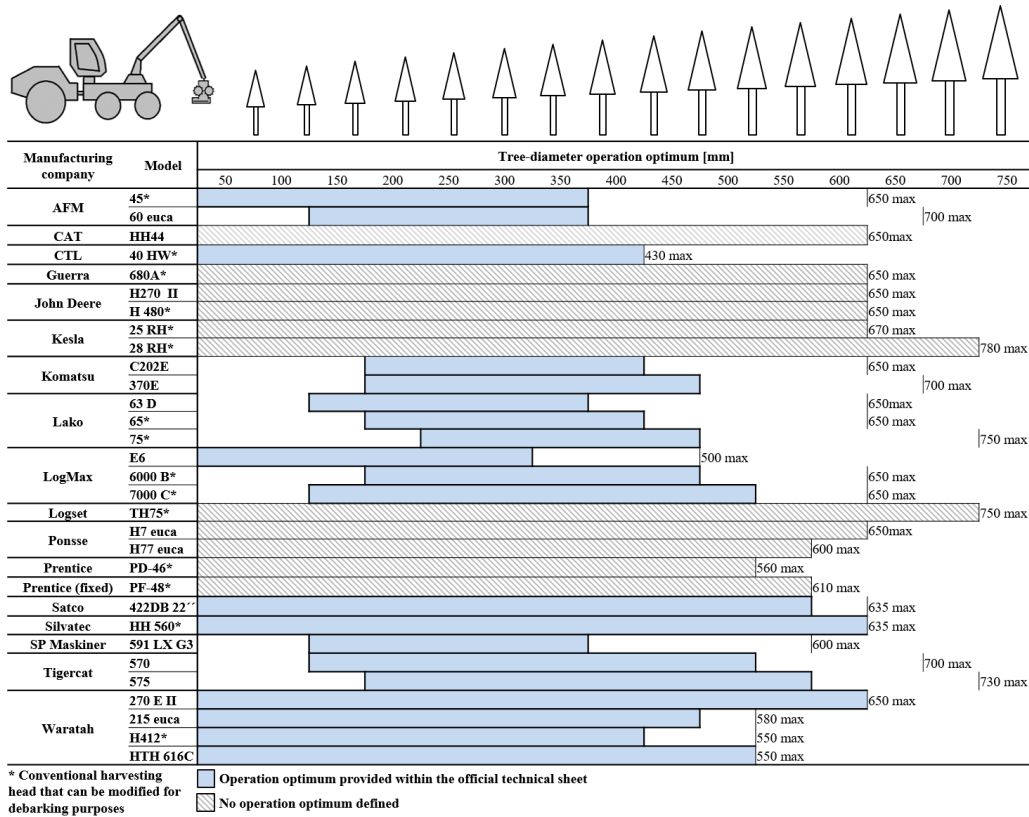


**Figure 3:** Content and structure of the thesis including the source of information

## 2. Materials and Methods

### *2.1. Selection, modification and testing of conventional harvesting heads*

Prior to testing, a market survey was accomplished in cooperation with the Kuratorium für Waldarbeit und Forsttechnik e.V. (KWF), to identify all available purpose-built debarking harvesting heads and harvesting heads that are listed as modifiable by the manufacturers. As a result of the survey, a potential pool of 31 harvesting heads was identified (Figure 4, Table 1). The optimum tree diameter was hereby an important factor as purposely-built harvesting heads are adapted for a certain diameter of grown Eucalyptus trees. However, under central European close-to-nature forests, a broad range of log diameters is present. This wide stem diameter distribution triggered the need to monitor harvesting heads with a broader optimum range of tree diameters. In a second step, some of the most commonly used harvesting heads in the German market were identified and compared based on their availability and current operability within German forests.



**Figure 4:** Debarking and modifiable harvesting heads available on the market, with the maximum and optimum operation spectrum (updated 2018)

The different hardware characteristics with varying feed rollers and knife count were also investigated during the decision process. Stem feeding systems ranged from two-wheeled feeding systems with only two outer feed rollers, to four-wheeled systems with two outer and two inner feed rollers (Table 1). Delimiting knives were differentiated between fixed and movable knives. Knife systems were composed of two to seven knives per head with usually 1–2 fixed knives and 2–4 movable knives (Table 1). The influences of feeding and knife systems on debarking ability were not known beforehand, but it was expected that harvesting

heads with different knife and feed roller systems would hence perform differently depending on the complexity and level of modifications.

**Table 1:** Overview of the 31 available debarking and modifiable harvesting heads, presented with the hardware characteristics (updated 2018)

Manufacturing company	Model	Number of feed rollers	Maximum opening of feed rollers [mm]	Number of knives	Movable knives	Fixed knives
AFM	45	3	550	6	4	2
	60 euca	3	600-660	3/4	2/3	1
CAT	HH44	2	620	4+2	4	2
CTL	40HW	2	-	3	2	1
Guerra	680A	3	600	5	4	1
John Deere	H270 II	3	620	6	4	2
	H480c	4	480	6	4	2
Kesla	25RH	2	580	4+1	4	1
	28RH	2	700	4+1	4	1
Komatsu	C202E	2	650	4	2	2
	370E	2	600	6	4	2
Lako	63D	3	-	4	3	1
	65	3	-	4	3	1
	75	3	-	4	3	1
LogMax	E6	2	630	5	3	1
	6000B	2	538	4	4	-
Logset	7000C	2	713	4	3	1
	Th75	3	740	6	4	2
Ponsse	H7 euca	3	630	6	4	2
	H77 euca	2	600	6	4	2
Prentice	PD-46	2	482	3	2	1
Prentice (fixed)	Pf-48	4	482	2	2	-
Satco	422DB	3	-	2+1	2	1
Silvatec	HH 560	2	-	6	5	1
SP Maskiner	591 LX G3	3	640	4	2	2
Tigercat	570	2	-	5	3	2
	575	3	725	5	3	2
Waratah	270 E II	3	620	6	4	2
	215 euca	2	550	7	4	3
	H412	4	530	5	3	2
	HTH 616C	3	660	4	3	1

In consideration of potential future applications of the investigated system, modifying conventionally used harvesting heads instead of testing purpose-built Eucalyptus debarking heads seemed reasonable. With this rationale, entrepreneurial costs for future applications could be lowered by up to a factor of 10 by avoiding the necessity to purchase a Eucalyptus harvesting head in favor of a more simple modification kit. To further expand the applicability of the modifications within central European harvesting operations, harvesting heads from three of the most common manufacturers of fully mechanized harvesting equipment were targeted.

This resulted in a cooperation with the manufacturers John Deere, LogMax and Ponsse. Following this initial selection, secondary search of harvesting heads for potential modifications were focused on products from these three companies. The availability of pre-existing parts and applicability of those parts onto common harvesting heads was hereby paramount. Apart from the technical compatibility of the chosen harvesting heads and modification parts, the harvester and the appropriate on-board computer operating software (Timbermatic, MaxiXplorer, Opti4G, Dasa, etc.) were also important decision factors. Therefore, in cooperation with the companies, modifications were performed on a John Deere H480C, LogMax 7000C and Ponsse H7 (Table 2). For succinctness, the combination of harvesting head and harvester will be referred to as Setup 1 (S1), Setup 2 (S2) and Setup 3 (S3).

**Table 2:** Harvesters and harvesting heads studied (Heppelmann et al. 2019a)

	Setup 1	Setup 2	Setup 3
Harvester	John Deere 1270E	Timberpro 620E	Ponsse ScorpionKing
Harvesting head	John Deere H480C	Log Max 7000C	Ponsse H7
Operator experience	8 years	4 years	13 years

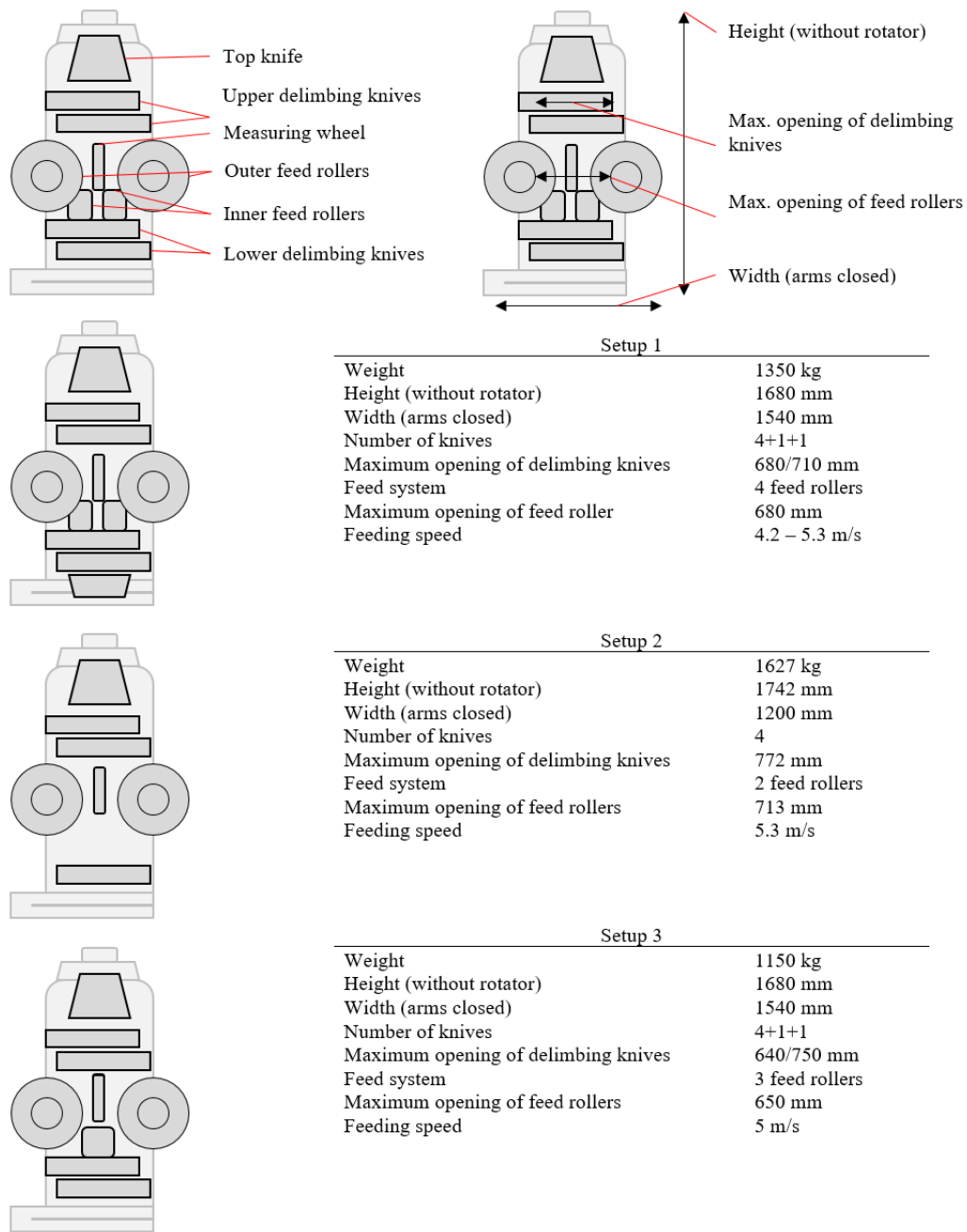
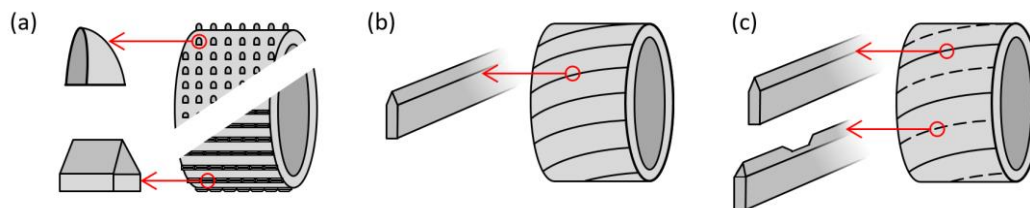


Figure 5: Technical specifications of the three modified harvesting heads



The three tested setups were modified with hardware parts from Eucalyptus heads, in order to add a debarking effect to the harvesting process. Therefore, the complexity of the modifications was minimized to limit the conversion costs, and thus primarily focused on feed rollers. By replacing the conventional feed rollers (Figures 6 and 7) with Eucalyptus debarking rollers, the harvested tree was forced to rotate along its longitudinal axis during the harvesting process. This allowed the delimiting knives to remove bark over the entire log surface. The blade-like edges on the debarking feed rollers cut the bark layer and additionally lifted small areas of the bark up from the wooden body, thus enabling the delimiting knives to slip in-between the bark and the wooden body.

The most common debarking feed rollers can be divided into two traction type sub-categories: single-edge and diamond-shape. Within the tests of S1 and S2 debarking harvesting head modifications, single-edge rollers were applied on the harvesting head (Figure 6b). The hybrid diamond-shape system was utilized during the S3 test operations (Figure 6c), which were based on a normal series of full-length splines that were alternating with a series of splines with edges. This alternating setup increased traction but lowered the rotational frequency of logs being processed.



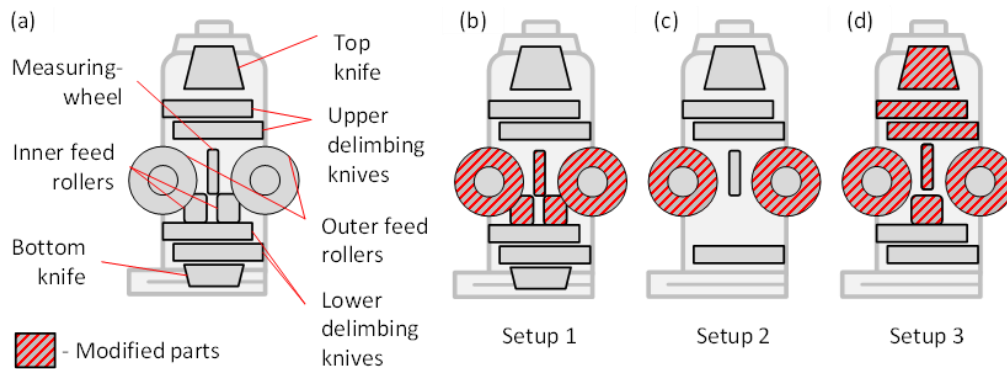
**Figure 6:** Different traction types of feed rollers with (a) Conventional spike-rollers without debarking effects or abilities, (b) Single-edge debarking roller, used within

the S1 and S2 tests, (c) Diamond-edge debarking rollers, used within the S3 tests (Heppelmann et al. 2019b)



**Figure 7:** Modified harvesting head prototypes from left to right: Setup 2, Setup 1 and Setup 3 (Debarking Head I 2018)

Due to the occurring lateral force caused by the longitudinal spin of the processed logs, the measuring wheel was also replaced with a less aggressive wheel on the S1 and S3 prototypes. This modification was done to prevent damage on the measuring unit, while also maintaining measurement accuracy. Within the S3 prototype setup, the harvesting head was further modified with newly developed top and upper delimiting knives designed in accordance with Eucalyptus delimiting knives but adapted to a larger range of harvested stem diameters (Figure 8). In addition to the technical modifications listed above, the harvesting head software settings such as feed pressure, knife pressure, feed speed, pressure curves, pitch angle of the delimiting knives, and the calibration of the measurement unit were also modified. These settings depended on various influencing factors such as tree species, tree dimensions and machine type, and thus needed to be adjusted individually for each machine setup and tested forest stand.



**Figure 8:** Modifications performed on the three different harvesting head prototypes with (a) General overview of modifiable parts of conventional harvesting heads; (b) Tested S1-Modifications; (c) Tested S2-Modifications; (d) Tested S3-Modifications (Heppelmann et al. 2019a)

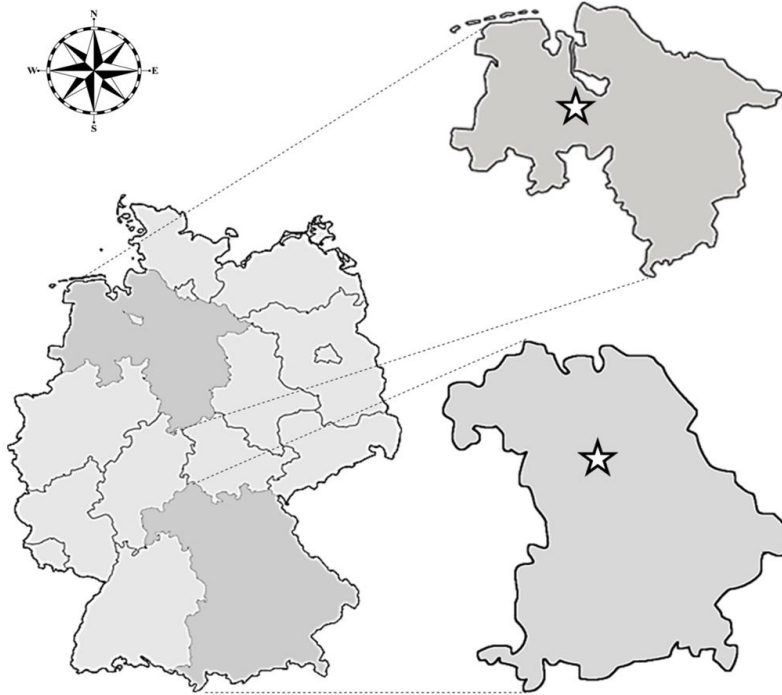
In addition to hardware and software modifications, the wood harvesting process was further altered with an additional step as compared to conventional mechanized CTL operations: the tree was fed one time over its complete length forward (step 1) and backward (step 2) through the debarking harvesting head prototype. Hereby, the trunk was spinning on its own longitudinal axis and the bark and branches were simultaneously removed during the first pass. The bark was removed on both forward and backward passes. The cross cutting of the stem into assortments (step 3) occurred during a third pass (Figure 9). Within all field trials, the operators were instructed to adhere to the above-mentioned process (steps 1 to 3), to obtain comparable measuring conditions for all investigated harvesting operations.



**Figure 9:** The S3 Setup in the Summer trial (Bavaria) on the third pass, cutting the stem into assortments after delimiting and debarking

## *2.2. Stand selection and characteristics*

As further described within Heppelmann et al. 2019b, three field tests were established in Lower Saxony and four field tests in Bavaria, Germany, to test the modifications performed on the three debarking head prototypes (Figure 10). To evaluate the influence of associated tree sap flow on debarking quality, tests were repeated in both summer and winter seasons. Summer and winter seasons were defined according to the German Meteorological Service (DWD), Winter: from Dec 01 - Feb 28/29; Summer: from Jun 01 - Aug 31 (Deutscher Wetterdienst 2019a).



**Figure 10:** Test sites located within Germany: Harpstedt  $52^{\circ}57'32.3''\text{N}$ ,  $8^{\circ}38'46.7''\text{E}$  - northern Germany (Lower Saxony); Kipfenberg  $48^{\circ}52'43.1''\text{N}$ ,  $11^{\circ}17'08.7''\text{E}$  - southern Germany (Bavaria) (Heppelmann et al. 2019b)

The test sites provided diverse stand characteristics and conditions as presented in Table 3. Within the initial test runs, ideal harvesting conditions (species, stem diameter, and tree form) for the debarking head prototypes were chosen to assess the performance of the carried out modifications under optimum conditions. The focus of the harvesting operations was set on Norway spruce (*Picea abies* L. H. Karst) and Scots pine (*Pinus sylvestris* L.).

**Table 3:** Basic stand characteristics presented by operation (Heppelmann et al. 2019b)

Operation	Location	Tree species composition	DBH	Age
Setup1 Summer I	Lower Saxony	Mixed coniferous stand – mainly Scots pine mixed with Norway spruce and Silver birch ( <i>Betula pendula</i> Roth)	15–20 cm	35
Setup1 Winter	Lower Saxony	Mixed coniferous stand – mainly Scots pine mixed with Norway spruce	15–25 cm	50
Setup1 Summer II	Lower Saxony	Pure coniferous stand of Scots pine	25–30 cm	70
Setup2 Winter	Bavaria	Mixed coniferous stand – mainly Norway spruce mixed with Scots pine and larch ( <i>Larix decidua</i> Mill.)	30–35 cm	65 (50–105)
Setup3 Winter <sup>a</sup>	Bavaria	Mixed coniferous stand – mainly Norway spruce mixed with Scots pine and larch	30–35 cm	65 (50–105)
Setup2 Summer <sup>b</sup>	Bavaria	Pure coniferous stand of Norway spruce	25–40 cm	30–100
Setup3 Summer <sup>b</sup>	Bavaria	Pure coniferous stand of Norway spruce	25–40 cm	30–100

<sup>a</sup> Intermediary trial performed in April, <sup>b</sup> Norway spruce bark beetle treatments

The S2 and S3 summer field tests were performed in spruce bark beetle infested stands. This was necessary since according to harvesting guidelines for the summer 2017, no fresh harvests were permitted within the Bavarian State Forests. Because of this, Scots pine was not present within those field trials.

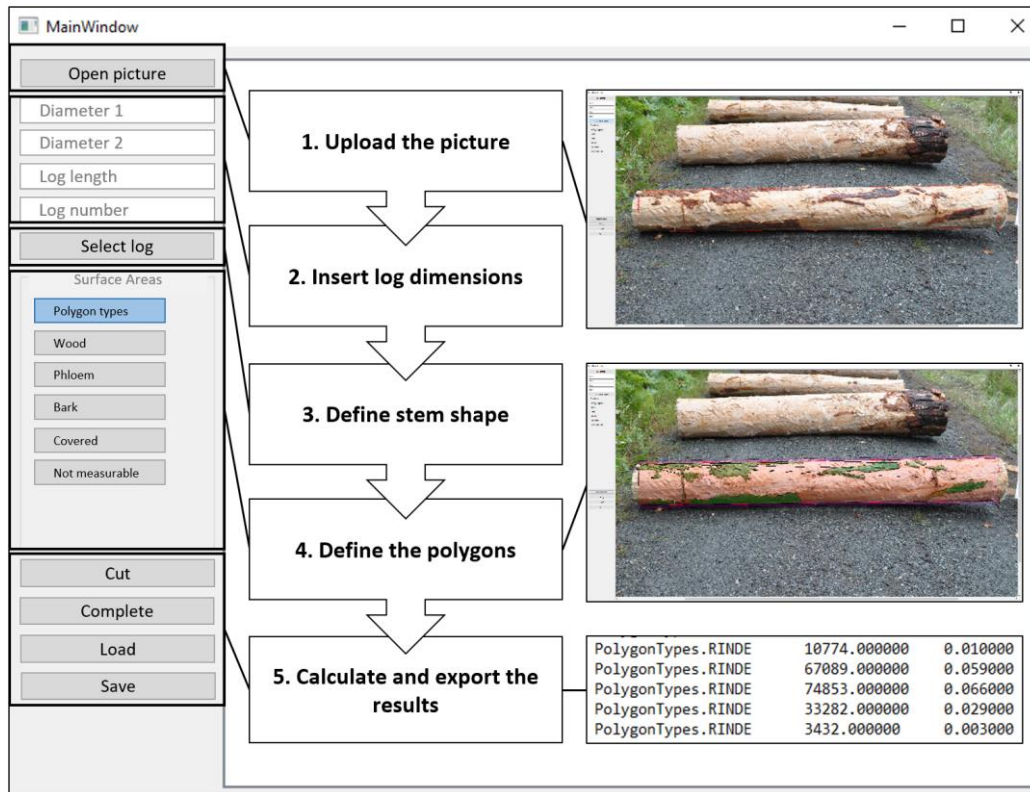
Due to delays of machine and stand availability, the S3 Winter test was implemented at the end of April and the sap flow was partly established. Therefore, S3 Winter is further listed as winter trial, but was considered as an intermediate or spring test and therefore not considered in further debarking percentages to season investigations.

### 2.3. *Stemsurf*

#### 2.3.1. *Stemsurf - general functions*

The evaluation of debarking results played a major role in the understanding of the effectiveness of the prototypes. Therefore, a measurement system with the ability to evaluate the debarking percentage directly in the field during live harvesting operations was required. For this purpose, as published in Heppelmann et al. 2019a, a software solution called *Stemsurf* was developed in cooperation with the company *Scientes Mondium UG*. The software was based on photogrammetric data of test logs and allowed the measurement of residual bark (phellem) and phloem areas.

*Stemsurf* is operating on a single broad-side photograph per log, recorded by a digital single-lens reflex camera and the physical properties of the log length and diameter on the small and large ends. Based on the gathered pictures, *Stemsurf* allows the user to mark different shares of areas characterized as bark, phloem, covered, not measurable and wood, thus taking advantage of the human ability of pattern recognition (Figure 11). According to the defined areas (manually drawn polygons), the log is divided in a series of frustums, defined by further gathered physical values of the log (length and diameter). In a final step, the absolute and relative shares of the defined polygons are calculated and extrapolated onto the complete log surface. More detailed information on the operating principle is available in Heppelmann et al. 2019a.



**Figure 11:** Schematic chart of the operating principle and working steps for the Stemsurf software (Heppelmann et al. 2019a)

### 2.3.2. *Stemsurf* - accuracy validation

To validate the accuracy of the developed software, tests were performed under laboratory conditions and presented within Heppelmann et al. 2019a. Therefore, a debarking percentage of 75% was simulated by attaching defined paper geometries emulating areas with bark remnants on a standardized log dummy without any taper or surface disturbances. To simulate the debarking percentage, exactly 25% of the log surface was covered with paper geometries that were randomly distributed over the entire log surface. In total, 480 pictures with unique debarking patterns were



recorded, measured and compared to the simulated and therefore known debarking condition. The laboratory tests were further divided into two test series (n=240 each), simulating the debarking percentage with either rectangle or round paper geometries, to assess a potential influence of bark remnant geometry on curvature and rounding effects within the software. The measured debarking percentages were averaged based on five varying sample sizes (n=12; 24; 48; 96; 240) and compared to the presented debarking condition, in order to assess the precision and bias of the tested Stemsurf software.

### 2.3.3. *Stemsurf - field applications*

In the field, debarked logs of the harvested trees were tagged with a unique number prior to being transported (Heppelmann et al. 2019a/2019b). This permitted individual logs to be retraced to a specific tree and even linked to their respective position within a tree (e.g. butt log, mid log, top log) later in the database. Following the identification, logs were transported by a forwarder to a nearby forest road or open-clearing and randomly placed in a parallel fashion perpendicular to the long axis of the road (Figure 12). To prevent overlays in the pictures, a spacing of approximately 2 m was maintained between adjacent logs. After the setup, log length and diameter at both ends were manually recorded using a caliper and measuring tape.

This was followed by recording a single broad-side picture of each log that was later evaluated within the Stemsurf software. Every picture was recorded with a picture number that was required to associate the images to the number tags attached to the log-end, as the logs were randomly placed on the exhibition site (Figure 12B). Overall, an average of 55 trees per test, resulting in a total of 1,720

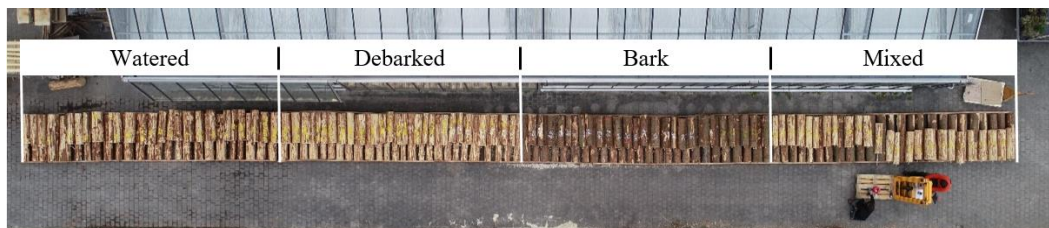
Norway spruce and Scots pine logs (976 logs within summer trials and 744 within winter trials), with varying lengths between 2.4 to 5.4 m and an average mid diameter of 8.0 to 54.7 cm, were recorded during the field applications.



**Figure 12:** A) Forwarding and arranging the debarked spruce logs on the forest road for debarking result measurements (summer tests, Bavaria); B) Setup of debarked pine logs for the evaluation of the debarking percentage, picture Nr. 1 (summer test, Lower Saxonia)

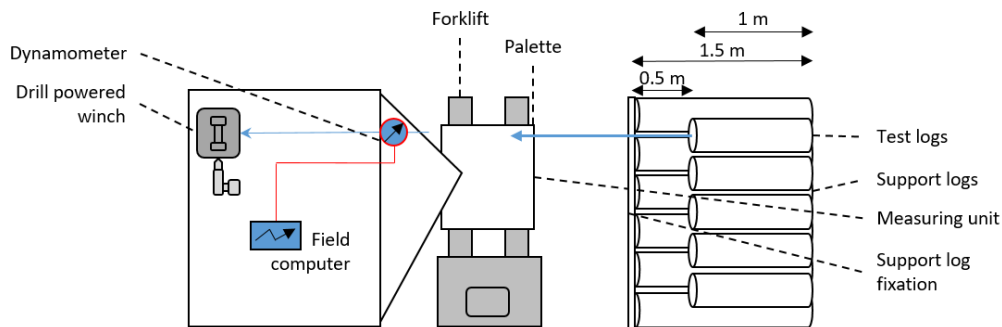
#### 2.4. Load safety test setup and measurements

A study was performed to assess the influence of debarked logs on load safety within ground-based transportation. As published in Heppelmann et al. 2019c, the static and sliding frictions of debarked logs were investigated and compared to bark logs and two further treatments (mixed stacks of debarked and bark logs; debarked logs exposed to simulated heavy rain events). Therefore, a fixed base layer of 104 Norway spruce logs of 1.5 m in length was created. In addition, 100 movable Norway spruce logs, measuring 1.0 m in length, were placed on top of the base layer and divided into four treatments: i) bark roundwood (bark); ii) debarked roundwood (debarked); iii) mixed (bark logs as base layer and debarked movable logs); iv) watered (debarked roundwood exposed to simulated consecutive heavy rainfall; Figure 13).



**Figure 13:** Top view of the test setup containing 100 test logs (1.0 m in length) lying on a row of support logs (1.5 m in length), divided into four different treatments (Heppelmann et al. 2019c)

Logs that required debarking were debarked manually before being placed in the test setup. In accordance with the VDI (Verein Deutscher Ingenieure) guideline VDI 2700 Part 14 of 2014, a portable measuring unit was constructed consisting of: i) a drill-powered winch (max. 2650 N pulling force); ii) a pushing/pulling force dynamometer (max. 1000 N, 0.5 N accuracy, 6 to 1600 Hz sampling rate,  $\pm 0.5\%$  accuracy); iii) a field computer for recording and direct data storage (Figure 14). The measuring unit was supported by an electric forklift that had moving and leveling capabilities to ensure a proper orientation of the unit with the measured test logs.



**Figure 14:** Schematic display of the static and sliding friction measuring unit setup (Heppelmann et al. 2019c)

The development of the static and sliding frictions was monitored during twelve test sessions occurring over seven days. Potential longer-term effects were also monitored through a thirteenth test session, carried out after 21 days. The measuring method was also based on the measuring procedure for friction determination described within the VDI guideline 2700. Due to particulars of the test requirements, the applied test procedure had to be slightly modified to ensure a high comparability between the four tested treatments. Within each test session, all test logs were pulled horizontally three consecutive times for a 10 seconds duration at

a speed of 100 cm per minute. The tension on the dynamometer was zeroed between each consecutive pull. A measurement frequency of 200 Hz was chosen to record all occurring friction changes during the pulling tests with a high resolution. This frequency resulted in 2000 single friction detections during the 10-second pulling period, all of which were directly recorded on the field computer. Average static and sliding frictions were then calculated based on the three consecutive pulls for every test session.

To monitor the mass and drying rate of the test logs, each log mass was determined before the first test session (Day 1), after test session 12 (Day 7) and after test session 13 (Day 21). To simulate the heavy rainfall on the watered assortment, debarked logs were watered before every trial with 25 l/m<sup>2</sup> in accordance with the definition for heavy rain of the German Meteorological Service (Deutscher Wetterdienst 2019b).

### 3. Main Results

#### *3.1. Precision and bias evaluated under laboratory conditions*

##### *3.1.1. Precision evaluation*

To test and evaluate the newly developed measurement system Stemsurf, laboratory tests were performed under controlled conditions and published in Heppelmann et al. 2019a. Based on these tests, the standard deviation of average debarking results was determined for varying sample sizes. Therefore, single polygon measurements were clustered and average wood and bark surface values were calculated and compared to the simulated debarking condition of 75% wood and 25% bark surfaces.

Within the tests, the measurements of single debarking percentages showed a wide deviation from the simulated debarking percentage of 26.5%–66.8%. The range decreased significantly after the single values were clustered in average debarking percentages to a deviation range for wood polygons of 0.3 % to 17.4 % (n=12) and 1.3% to 7.4% (n=96), (Table 4). This range further decreased for the investigated bark polygons from 0.8% to 4.2% (n=12) and 0.2% to 2.8% (n=96).

Overall, the results presented multiple standard deviations that remained within the desired range of 5%. Standard deviations for measured wood polygons ranged from 2.0% (n=96, round geometry) to 4.0% (n=12, round geometry). For the tested bark geometries, the standard deviations of calculated average debarking percentages ranged from 1.5% (n=12 rectangular geometry) to 0.7% (n=96, round

geometry) and were therefore considerably lower than for the calculated wood polygons (Table 4).

**Table 4:** Descriptive statistics presenting the main results comparing the calculated average debarking percentages (Heppelmann et al. 2019a)

Polygon	Test Series	Sample Size (%)	Standard Deviation (%)	Range (%)	Minimum (%)	Maximum (%)	Deviation Range*
Wood	Rectangular	12	3.95	17.4	74.7	92.1	-0.3-17.1
	Round	12	3.98	14.5	75.3	89.9	0.3-14.9
	Rectangular	24	3.19	9.9	76.2	86.0	1.2-11.0
	Round	24	3.35	10.0	75.8	85.8	0.8-10.8
	Rectangular	48	3.00	8.0	76.3	84.2	1.3-9.2
	Round	48	2.94	6.1	77.3	83.4	2.3-8.4
	Rectangular	96	3.44	6.2	76.3	82.4	1.3-7.4
	Round	96	1.97	3.9	77.4	81.3	2.4-6.1
Bark	Rectangular	12	1.54	5.5	23.7	29.2	-1.3-4.2
	Round	12	1.05	3.5	25.8	29.2	0.8-4.2
	Rectangular	24	1.25	3.8	24.3	28.1	-0.7-3.1
	Round	24	0.91	3.2	25.8	29.0	0.8-4.0
	Rectangular	48	1.14	2.8	25.0	27.8	0-2.8
	Round	48	0.87	2.1	26.1	28.3	1.1-3.3
	Rectangular	96	1.50	2.6	25.2	27.8	0.2-2.8
	Round	96	0.69	1.2	26.1	27.3	1.1-2.3

\*Deviation of average debarking percentages from 75% for wood and 25% for bark polygon measurements under controlled conditions

### 3.1.2. Bias evaluation

To further evaluate the accuracy and performance of Stemsurf, a more detailed analysis of bias was performed (Heppelmann et al. 2019a). Therefore, the following assumptions were presumed: i) the estimates of parameters  $E(\Theta)$  equals the true parameter  $\theta$  if a measurement system delivers unbiased results. ii) the difference is  $E(\Theta) - \theta = 0$ . iii) if the results are biased,  $E(\Theta)$  is either greater or smaller than  $\theta$ . The parameter is then systematically overestimated if  $E(\Theta) > \theta$  (positive bias) or systematically underestimated if  $E(\Theta) < \theta$  (negative bias).

For the laboratory tests, the bias was positive for the tested estimates of parameters of  $n = 240$ , in favor of the bark polygon measurements with a lower difference (0.8% for rectangular geometries, 1.7% for round geometries) in comparison to the difference of wood polygon measurements (5.5% for rectangular geometries, 4.6% for round geometries). This tested positive bias therefore described a systematic overestimation of the measured bark polygon shares. After a relative area correction was calculated to consider the different surface shares of the polygons, the corrected difference between estimates of parameters ( $\text{CorrE}(\Theta)$ ) and the true parameter ( $\theta$ ) accounted for 7.3% and 6.1% for wood polygons and 3.2% and 6.8% for bark polygons of square and round geometries (Table 5). When considering the 3.2% (rectangular bark geometries) as an outlier, the average positive bias equaled to 6.7%. Considering the overestimation of bark proportions that lead to a systematically lower debarking percentage, results of the summer tests should be considered as rather conservative.

**Table 5:** Descriptive statistics of the calculated average debarking percentages ( $n = 240$ ) compared to the true simulated debarking percentages of the laboratory surveys (Heppelmann et al. 2019a)

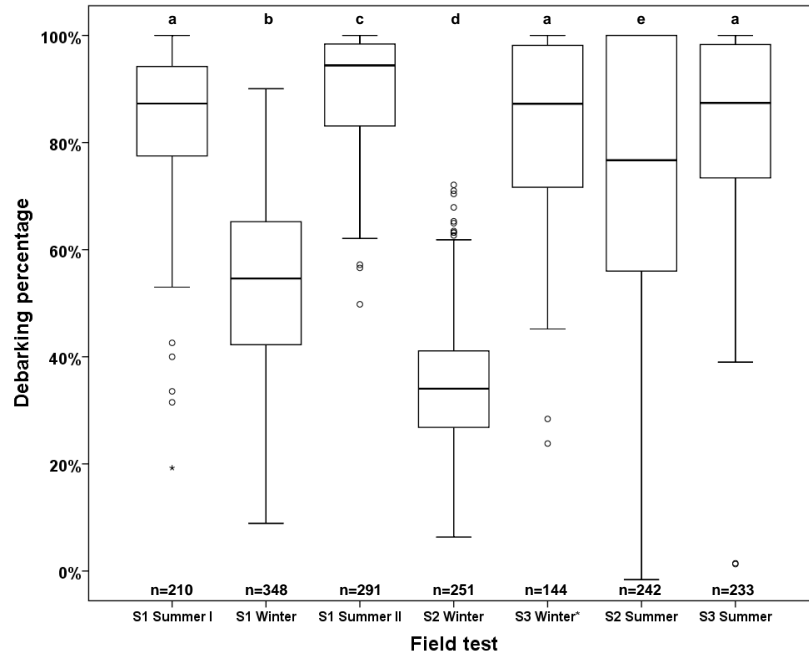
Polygon	Test Series	$E(\Theta)$ (%)	$\theta$ (%)	$E(\Theta) - \theta$ (%)	$\text{CorrE}(\Theta) - \theta$ (%)
Wood	Rectangular	80.5	75	5.5	7.3
	Round	79.6	75	4.6	6.1
Bark	Rectangular	25.8	25	0.8	3.2
	Round	26.7	25	1.7	6.8

$E(\Theta)$  - Estimates of parameters;  $\theta$  - True parameter;  $\text{CorrE}(\Theta)$  - Area-corrected estimates of parameters.



### *3.2. Effect of machine type and season on debarking efficiency*

A general overview of the full dataset within Heppelmann et al. 2019b presented the achieved average debarking percentages, and uncovered multiple significant differences between the single field trials. The influence of season and associated sap flow resulted in the most prominent difference, with findings being more favorable for summer trials. In comparison to the summer trials, the average winter debarking percentage was reduced by 46%. The S3 winter trial was hereby not included within the calculations, due to delays within the preparation of the trial and the classification as an intermediate trial (performed in April). Statistical investigations (ANOVA followed by Tamhane and Dunnet-T3 post hoc) revealed significant differences not only between the harvesting seasons but also between the tested setups. Within the summer trials, S1 Summer I, S3 Summer and S3 Winter performed similarly, while the S1 Summer II test delivered the highest average debarking percentage with 90% (Figure 15). In contrast, the S2 Summer test produced logs with an average debarking percentage of 73% overall. The S1 and S2 setups also showed significant differences within the average debarking percentages during winter harvesting/debarking operations (35% and 54%), favoring the S1 setup with 54%.



**Figure 15:** Overview of all measured debarking percentages and significant differences (a to e) within the different field tests (pine and spruce species combined): S1 - Setup 1, S2 - Setup 2, S3 - Setup 3 (Heppelmann et al. 2019b)

When considering the results of the bias evaluation within the laboratory tests, debarking percentages from field operations were slightly underestimated (bark remnants were slightly overestimated) and were hence considered as conservative (Table 5). Therefore, a bias correction was calculated based on equation 1, to test the deviation caused by the bias on the gathered results and displayed in Table 6.

$$\text{CorrD}\% = 100\% - \left[ (\text{Bark}\% + (\text{Phloem}\% * 0.5)) - (\text{Bark}\% + (\text{Phloem}\% * 0.5)) * 0.067 \right] \quad (1)$$

*CorrD%* denotes the corrected debarking percentage, *Bark%* indicates the percentage of bark residues and *Phloem%* indicates the percentage of phloem residues

The results showed that the systematic error was increased within the winter tests by 3.1 and 4.4 percentage points when compared to the summer tests with an average deviation of 1.1 percentage points (Table 6). The systematic error did however remain within the anticipated deviation range of 5%.

**Table 6:** Measured average debarking percentages obtained from field applications and corrected based on findings of the laboratory accuracy validation (Heppelmann et al. 2019a)

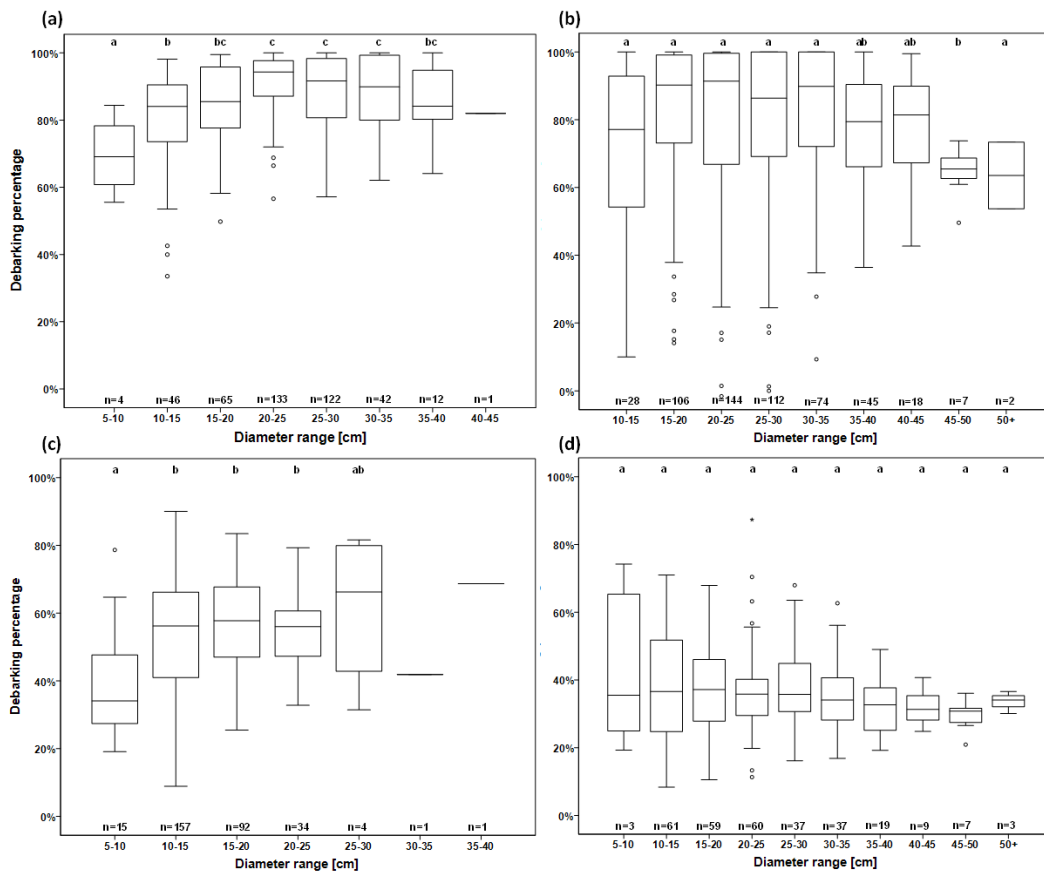
Field Tests	S1 Summer I (%)	S1 Winter (%)	S1 Summer II (%)	S2 Winter (%)	S3 Winter (%)	S2 Summer (%)	S3 Summer (%)
Debarking percentage	84.1	53.8	89.9	34.8	83.4	73.1	83.8
Corrected debarking percentage*	85.1	56.9	90.6	39.2	84.5	74.9	84.9

\* Recorded average debarking percentages of summer and winter field applications, corrected considering a bias factor.

### *3.3. Effect of log diameter, species and season on debarking efficiency*

To assess the influence of log diameter on debarking efficiency, log diameters were clustered and differentiated into categories of 5-cm increments (Heppelmann et al. 2019b). The differentiation was expanded by further dividing the debarking results depending on harvesting season and tree species (Figure 16). Overall, it can be stated that for the summer trials the average debarking percentages described an inverse parabola with the maximum average debarking result of 91% at 20 to 25 cm log diameter for pine summer and 82% at 30 to 35 cm for spruce summer (Figures 16a and b). For both smaller and larger diameters, the average debarking percentages tended to be lower.

This effect appeared to increase for harvested and debarked Scots pine logs compared to harvested logs of Norway spruce. This trend continued for the pine winter operations with a maximum average debarking percentage of 57% at a diameter range of 15–20 cm and in comparison, lower debarking percentages to both extremes of the diameter scale. Average debarking percentages for log diameters greater than 25 cm were not considered due to the small sample size of  $n \leq 4$  (Figure 16c). However, no significant differences between the average debarking percentages of varying log diameter classes was detected but a decreasing variance towards larger diameters for the spruce winter harvesting operations were noticeable (Figure 16d).

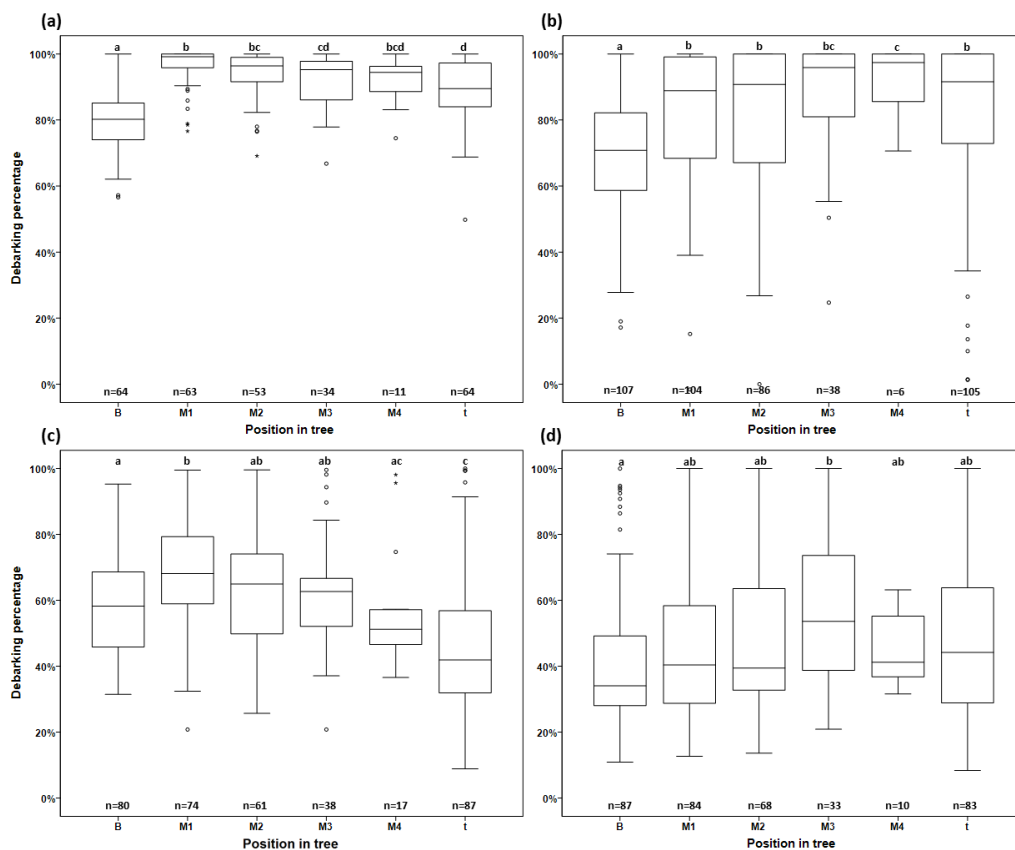


**Figure 16:** Overview of the measured debarking percentages and significant differences (a to c) by 5-cm log diameter categories and species/season according to: (a) pine summer, (b) spruce summer, (c) pine winter and (d) spruce winter trials (Heppelmann et al. 2019b)

### 3.4. Effect of log positioning in tree, species and season on debarking efficiency

To determine if the vertical position of a log within the tree had an influence on the debarking result, the database was filtered according to position within the tree such as butt log (B), middle log ( $M_x$ ) and top log (t). Statistical analyses

presented in Heppelmann et al. 2019b, revealed significant differences between the average debarking results (62%) of butt logs compared to middle logs favoring the middle logs with a 15% higher average debarking percentage (73%). A similar effect was detected for top logs (66%), resulting in a 9% lower average debarking percentage compared to mid logs (Figure 17).



**Figure 17:** Overview of the measured debarking percentages and significant differences (a to d) by vertical position of the log within the tree (B- Butt log; M1–M4- Mid positioned logs, t- Top log) and species/season according to: (a) pine summer, (b) spruce summer, (c) pine winter and (d) spruce winter trials (Heppelmann et al. 2019)

### 3.5. Development of static and sliding frictions single test wise comparison

To test the influence of the debarking procedure onto load security, the static and sliding frictions were tested within a study published in Heppelmann et al. 2019c. During the test setup, the mass of all test logs was determined and recorded at three different time intervals, revealing significant differences regarding the drying rate within the four tested treatments bark, debarked, mixed and watered (Table 7). While the watered treatment showed almost no drying effect within the first seven days, the treatments including debarking presented a 40 to 45% faster drying rate compared to the bark treatment.

**Table 7:** Mass reduction of the test logs within the friction test setup after 7 and 21 days (Heppelmann et al. 2019c)

<b>Treatments</b>	<b>Bark</b>	<b>Debarked</b>	<b>Mixed</b>	<b>Watered</b>
Mass reduction after 7 days	4.0%	7.2%	9.0%	2.7%
Mass reduction after 21 days	16.7%	27.8%	29.3%	23.5%

### 3.5.1. Static friction

As the log mass proved to have a strong influence on both static and sliding frictions (Heppelmann et al. 2019c), this influence was eliminated by referencing the applied pulling force to the log mass ( $N_{\text{Pull}}/\text{kg}_{\text{Log}}$ ). Concerning the static friction (Table 8), no significant differences were detected between the treatments debarking (7.61 N/kg), mixed (8.31 N/kg) and watered (7.83 N/kg). However, static friction (9.94 N/kg) of the bark treatment was significantly higher throughout the first six days, while this significant difference tended to decline over the test period.

Within the twelfth test on day seven this significant difference between bark and debarked/mixed was no longer present (Table 8). However, water still showed a significant influence on surface friction interactions and hence a significant difference between the static friction of the treatments bark and watered was detected. This difference disappeared within the control test after 21 days as well.

**Table 8:** Average static frictions in  $N_{\text{Pull}}/\text{kg}_{\text{Log}}$  of test sessions 1, 12, and 13 as well as minimum, maximum, and overall average (Heppelmann et al. 2019c)

Treatment	Static friction					
	Average test session 1	Average test session 12	Average test session 13	Min.	Max.	Overall average
Bark	9.94	9.94	9.20	9.20	11.45	10.52
Debarked	7.61	9.24	8.92	7.61	9.24	8.31
Mixed	8.31	9.24	8.76	8.44	9.24	8.44
Watered	7.83	8.62	8.41	7.44	8.62	8.09



### 3.5.2. *Sliding friction*

Differences within the sliding friction of the four tested treatments showed a higher variance compared to static friction. As presented in Heppelmann et al. 2019c, significant differences were detected throughout the bark and watered treatments within the test period favoring the bark treatment. In six out of 13 test sessions, significant differences were detected between all four treatments. The significant differences between the bark and debarked treatment were also present after seven days favoring the bark treatment with a 19.6% higher sliding friction (Table 9).

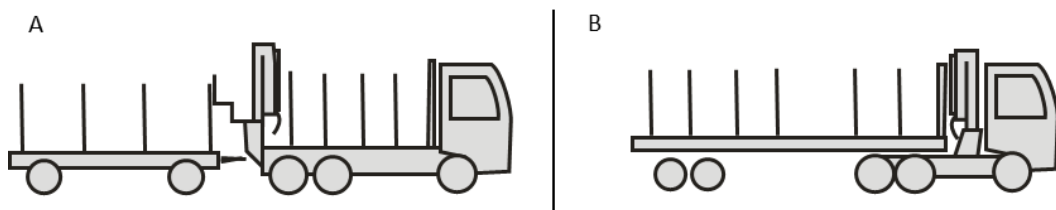
Similar to the static friction development presented above, the difference between the sliding friction of the bark and debarked treatments was not detectable after a drying period of 21 days. However, water continued to significantly reduce the sliding friction, even after 21 days.

**Table 9:** Average sliding frictions in  $N_{\text{pull}}/kg_{\text{Log}}$  of test sessions 1, 12 and 13 as well as minimum, maximum, and overall average (Heppelmann et al. 2019c)

Treatment	Sliding friction					
	Average test session 1	Average test session 12	Average test session 13	Min.	Max.	Overall average
Bark	7.54	7.93	6.89	6.89	8.42	7.99
Debarked	4.77	6.63	6.92	4.42	6.92	5.60
Mixed	5.51	7.29	7.03	5.01	7.29	6.20
Watered	4.16	4.59	4.63	4.08	4.63	4.32

### 3.6. Influence of debarking treatment on load volume and mass

Besides the influence on the static and sliding frictions and therefore on load security, debarking was also expected to have an influence on load volume and load mass of different truck and trailer combinations. Therefore, the development of the load mass and volume was calculated in Heppelmann et al. 2019c for the two most common transport setups for short-wood transportation on German roads (Korten and Eberhardinger, 2008a): a combined truck with loading space and short trailer (Figure 18A) and a truck with a single long trailer (Figure 18B).



**Figure 18:** Schematic display of (A) self-loading combined truck with short wood trailer providing a lorry length of  $2.0 \times 5.1$  m and lorry width of 2.27 m and (B) self-loading truck with long trailer and a lorry length of 13.0 m and lorry width of 2.4 m (modified after Jörn Erler, Heppelmann et al. 2019c)

According to Heppelmann et al. 2019c, the calculations were based on: i) the technical information of the truck suppliers (Table 10); ii) the German legal maximum total mass of 44 tons for (A) combined truck and trailer system and 40 tons for (B) conventional truck and trailer system (German Schedule of Fines and Penalties 2019); iii) a correction factor of 0.6 to consider the air voids between the logs (Reisinger et al. 2009). Furthermore, the wood density ( $\text{kg/m}^3$ ) for bark and debarked wood was calculated from log masses obtained during the friction tests.

**Table 10:** Machine-related characteristics and dimensions considered within the loading and mass capacity calculations (Heppelmann et al. 2019c)

Machine	Tare mass [t]	Loading capacity [t]	Loaded mass [t]	Lorry width [m]	Loading height [m]	Lorry length [m]	Load volume capacity [m <sup>3</sup> ]	Correction factor
(A) Truck	11.9	6.1	18.0	2.27	2.4	5.1	16.7	0.6
Trailer	4.9	19.1	24.0	2.27	2.4	5.1	16.7	0.6
(B) Truck	7.5		7.5					
Trailer	5.3	27.2	36.0	2.4	2.4	13	44.9	0.6

For the combined truck and trailer system (A) both limiting factors (mass and volume) were present and resulted in a 1.1% additional volume ( $\text{m}^3$ ) of transported debarked wood and cargo mass reduction of 2.3% per load on day 1, when compared to a full load of bark roundwood. After a longer drying period of seven days, this effect added up to a 2.2% increased load volume of debarked roundwood transported and 4.4% lower cargo mass. This incline further increased after 21 days resulting in 6.8% potential addition of transported debarked roundwood and a 10.5% reduction in cargo mass (Table 11).

Within the second truck and long trailer transport system (B) calculations, load capacity acted as the limiting factor within the first seven days, making an overloading by mass improbable (>40 tons) of the truck/trailer system. Caused by an approximately 40% faster drying rate, a potential additional net load of 3.4%, 7.0%, and 11.0% were calculated for the days 1, 7, and 21 (Table 11), respectively. After 21 days, the volume started to act as a limiting factor too. This resulted in the above-mentioned additional net load of 11%, while reducing the total cargo mass by 6.9% compared to a full load of bark roundwood after 21 days.

**Table 11:** Calculated differences between debarked and bark assortments concerning additional load and total mass of the loaded truck and trailer combination, after certain drying periods (Heppelmann et al. 2019c)

<b>Machine</b>	<b>Day</b>	<b>Additional loaded m<sup>3</sup> [%]</b>	<b>Cargo mass difference for full loaded lorry bark/debarked [%]</b>
A) Truck/Trailer 2.4 m max. load height	1	1.1%	-2.3%
	7	2.2%	-4.4%
	21	6.8%	-10.5%
B) Truck/Trailer 2.4 m max. load height	1	3.4%	0%
	7	7%	0%
	21	11%	-6.9%

## 4. Discussion

### *4.1. Debarking head modifications*

#### *4.1.1. General modifications*

A major benefit proved to be the simplicity of the modifications. First, by modifying existing harvesting heads instead of developing a new harvesting head, future investment costs for entrepreneurs were decreased by approx. 90% (head: ~90,000 €; modification set: 5,000 €–10,000 €). Second, as no new parts had to be developed, all used parts were already available and were easily distributed by the manufacturing companies. Therefore, modification kits are already available and introduced into the market. In 2017, only the three harvesting prototypes developed within the study were operated within German forests. In 2019, this number increased to over 30 during spruce bark beetle harvests (Hauck and Prüm 2019).

Based on the stage of the modifications (Figure 8) and the parts that were mandatory to be modified, the demands on modifying time and the location at which those modifications could be performed varied. Modification of the S1 and S2 setups was performed directly in the forest stand and took approx. half a day for the S1 setup and 1 to 2 hours for the S2 setup. The increased modification time of the S1 setup was caused by the modification of the inner feed rollers that had to be disassembled together with the attached engines. The disassembling and reassembling were therefore more complex than just changing the outer feed rollers of the S2 setup but were in both instances performed by the harvester operators (Figure 8). However, the complexity of the modification including the upper

delimiting knives of the S3 setup required a professional surrounding of a workshop and a professional mechanic. Time requirement for the modification was therefore increased to a full day. Modifications of the S3 setup provided high flexibility for the entrepreneur.

If the debarking process is required within short-term harvesting operations, the modifications can be carried out within a condensed time. After the completion of the harvest, the harvesting head could be returned to a conventional setup. This benefit could also change for future setups as the modifications might become more complex and adapted to special areas of application.

#### 4.1.2. *Feed rollers*

Modifications of the S1 setup during the S1 Summer I field test exceeded all expectations. With the first application of a debarking procedure on Norway spruce and Scots pine, the system delivered outstanding results with an overall average debarking percentage of 84.1% (Figure 15). However, it is important to mention that these results were obtained after some extensive fine-tuning of machine settings within the first 100 m<sup>3</sup> of harvested wood. During this test period, damages on the wooden body were a major issue because of the increased feeding pressure being applied to the less aggressive debarking rollers. Increased pressure was necessary for the feed rollers to have better traction on the stem but resulted in significant damage on the log surface and segments with loose fiber structure. Several trials on the applied feeding pressure curve configurations resulted in an optimal feeding pressure that was 20% lower than the conventional feeding pressure used for harvesting operations with spiked rollers. The applied lower feeding pressure seemed to be a suitable compromise between sufficient feed roller traction and

reduced surface damage on the wooden body and was hence utilized with all field operations. Through an associated study, Labelle et al. (2019) actually reported significantly shallower (2 mm) damage on the wooden body caused by debarking feed rollers (Figure 6) compared to conventional spiked rollers performed within the same harvesting operation. Furthermore, no bark material was dislocated into the wooden body by the debarking rollers, due to the extended contact area provided by the bars.

Besides these beneficial effects concerning the severity of wood damage, modified feed rollers presented three major effects. First, rotating the log during the feeding process allowed the feed rollers and debranching knives to process on an approximately 360-degree surface, thus almost evenly debarking the entire log surface. Second, the knife shaped edges on the feed rollers were able to cut the bark into segments, creating ridges that could be grabbed by the delimiting knives, while loosening the bark on large areas through the applied shear forces. Third, the rotating effect also reduced the frequency of bark residues clogging the harvesting head and hindering the free rotation of the measuring wheel. Those effects were similar within the three-tested setups. However, the rotating frequency of a stem within the harvesting head remained highly variable, with the lowest frequency for the S3 setup due to the hybrid diamond shaped feed rollers and the highest rotating frequency for the S2 setup. Nevertheless, no correlation between the rotating frequency per stem and the debarking results could be observed during field operations nor detected in the dataset.

#### 4.1.3. *Delimiting knives*

In addition to the modification of the feed rollers (Figure 8), the settings of the delimiting knives had to be altered to achieve a satisfying debarking result. Therefore, on-board computer settings relating to knife pressure and knife vibration had to be adjusted. These site-dependent modifications were based on the operator experiences (Table 2). For future applications of the system, guidelines should be provided by the manufacturing companies to support harvester operators in the decision making of the on-board computer settings. Furthermore, the knives themselves were adjusted towards a more aggressive cutting edge by manually reducing the counter grind with an angle grinder. This particular modification should not be repeated too frequently as it decreases the lifespan of the delimiting knives.

In particular, the S3 setup tests revealed a high potential for future improvements of knife modifications. Initial tests utilizing original knives of an H7euca head failed due to the fragile designed shape for small diameters that caused high damages on the wooden body and broke during the debarking process of logs with a diameter exceeding 30 cm. To address this problem, new knives were designed and fabricated based on the original H7euca knives, while considering a stronger material, larger opening angle and a cutting edge on both sides of the delimiting knife. This development was performed by the local distributor (Wahlers Forsttechnik) of the S3 setup and was clearly beneficial by providing debarking percentages with over 90% (Figure 15) despite the irritations within the field applications through intermediate season with no fully established sap flow (S3 Winter) and spruce bark beetle infestations (S3 Summer).



Hardware and software modifications of the knives of all three tested setups revealed two further effects. First, the delimiting of larger diameter branches was eased by the more aggressive knife settings and the rotating effect caused by the debarking rollers, thus resulting more in a cutting rather than a chopping effect. Second, due to the modified settings, the damages onto the wooden body were significantly increased as the knives tended to cut deeper into the wooden body on contact (Labelle et al. 2019).

#### *4.1.4. Measuring wheel*

Due to the modification of the measuring wheel, length measurement from the modified harvesting head operated within an acceptable range. Overall, 86.2% of the manually controlled log lengths were within the given saw window of 5 cm (accepted deviation range), whereas 7.0% were too short and 6.8% too long. Shorter logs were hereby seen as more problematic than longer logs when compared to manual measurements, as they did not meet the requirements for the target assortment. However, 66% of the outliers were detected on short industrial wood that was destined to be chipped for animal litter and hence accurate length measurement was rendered trivial. Nevertheless, an accurate length measurement highly depends on a responsible calibration of the debarking harvesting system during the first harvested trees within a new harvest, as stand characteristics such as tree and crown architecture are suspected to have a major influence on length measurement accuracy.

#### 4.1.5. *Productivity*

Through the modifications and especially the adaption of the harvesting procedure, a decreased harvesting productivity of approximately 10% when compared to conventional harvesting operations was measured by the associated project partners of the Kuratorium für Waldarbeit und Forsttechnik e.V. (KWF). The intensified handling of the entire tree within the debarking process also triggered a 20% increase in fuel consumption. This resulted in additional costs of approximately 2.5 to 5.5 €/m<sup>3</sup> (Debarking Head I 2018). Within this calculation, no entrepreneurial profits and potential increased wear off were included. Furthermore, this calculation is based on approx. 600 m<sup>3</sup> of harvested wood with and without debarking. Therefore, the results should be considered as general observations. However, a study carried out by Magagnotti et al. (2011) reported a range of 11 to 17% for savings of Eucalyptus harvestings without debarking, thus supporting the plausibility of the calculated additional cost range based on the field operations performed in this study.

Overall, it can be stated that the modification proved to be financially feasible and able to produce good debarking results with a minimum amount of modification effort within summer harvesting operations. However, further development potential exists for winter harvesting operations if debarking outside of the vegetation season becomes a desirable option.

#### 4.2. *Stemsurf*

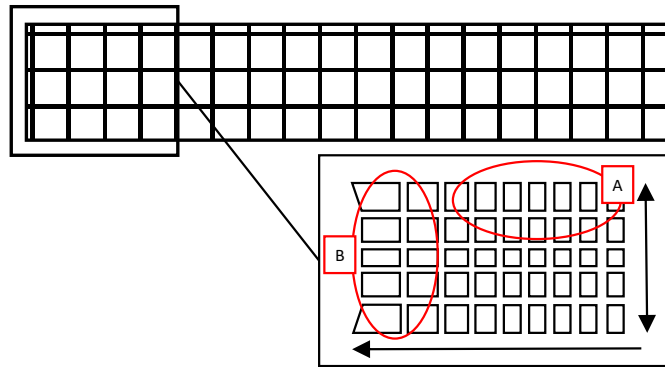
To evaluate the debarking results, a software solution was developed to record the debarking percentage directly in the field without affecting ongoing harvesting operations. The software solution, presented in Heppelmann et al. 2019a, was based on a mathematical model of the recorded log and manual delineation of the different surface areas defining the log surface. Similar to modifications performed on the harvesting heads, a major benefit of the developed measurement system lied in its inherent simplicity and user-friendliness. The fact that the system operated fast and delivered very robust measurement results of debarking percentages recorded directly in the forest stand, permitted users to record large amount of data within a rather short period of time. The measurement of the debarking percentage was done in a subsequent step in the office, reducing the weather dependency of the whole system.

Within the laboratory tests, *Stemsurf* showed a high variance within the single debarking percentages. This was a consequence of measuring a single perspective of the log that displayed a maximum of 50% of the log surface. The remainder of the log surface was estimated proportionally. The single debarking percentage was therefore highly dependent on the position of the log and the display of the surface in relation to the positioning of the reflex camera. However, it was expected that within the field studies, the debarking effect occurred rather equally over the log surface as the tree rotates through the harvesting head while the log is being processed.

The position of the bark remnants was determined by a randomizer and might therefore not be distributed as equally as in live operations, thus possibly leading to higher variances. Additionally, the system was not developed to measure an exact

debarking percentage on one single log, but rather to provide an average debarking percentage over a larger database within a short measuring period. Therefore, the variance within the single debarking percentages was less relevant considering the use for infield application via averages. This was supported by the fact that within the laboratory tests, Stemsurf provided precise average debarking percentages with both small and larger sample sizes remaining within the anticipated deviation range of 5% for all control tests.

A potential influencing factor on the measuring result and precision was determined to be the distortion within a picture. This distortion was caused by the 3D measuring attempt within a 2D projected environment. Within the display of the log, all pixels in the photo-shot had the same dimension and covered the same area. However, due to distortion effects and the angle of view, pixels represented a different surface area when calculated onto a 3D log. The defined area on the log increased for polygons, consisting of pixels that were located far to the longitudinal edges and outside areas of the log (Figure 19). At these respective areas, the vision of the camera had to be considered on a steep tangential angle. The calculation of the distortion was hence the main challenge within the development of the Stemsurf software and most likely the main cause for deviation and false measurements.



**Figure 19:** Schematic of a 2D projection of a log via equal pixels and the expected described log surface with (A) longer areas towards the outside and (B) wider areas towards the extremities of the pictured log. The arrows indicate the direction of exceeding surface areas defined by a single pixel (Heppelmann et al. 2019a)

After solving the issue with the distortion effects in the software, the measurement system functioned precisely and provided low standard deviations (Table 4) with a considerably lower bias (Table 5). Stemsurf met the expectations and delivered robust results within the area of application. Besides the experiences with Stemsurf, very limited research has been published regarding methods of measuring debarking percentages that could have been compared to the gathered results, as this was the very first attempt to test and evaluate harvester-based debarking of Norway spruce and Scots pine stands. Baumgartner et al. (2007) performed a study in which rectangular geometries were debarked by hand on Norway spruce logs and were then scanned with industrial scanning technology (Microtec Tomolog®) to determine the difference in accuracy on bark thickness between manual and scanner-based measurements. Such existing scanning technology was also considered within the research project but was rejected due to the logistic effort and costs of transporting the logs to a measuring facility and then additionally to the intended end-user.

Moreover, light detection and ranging (LiDAR) solutions rely on contour-based detection. In this instance, defects such as depressions and knobs present on a stem can limit the accuracy of the debarking result measurements as they impede a clear characterization as wood or bark surface (Thomas et al. 2007). The human pattern recognition of Stemsurf was not effected by such limitations.

#### *4.3. Positive effects of in-stand debarking*

##### *4.3.1. Effects on the nutrient supply of forest ecosystems originating from in-stand debarking harvesting operations*

During harvester-based in-stand debarking operations, a large share of bark remained within the forest ecosystem. The bark left on site could help to maintain soil fertility of forest stands. As reported by Weis and Göttlein (2012), stored nutrient shares of Norway spruce bark affected by spruce bark beetles showed a share of 14% nitrogen, 17% phosphorus and 31% calcium of the total tree nutrient content. This means in effect that within the bark, an amount of calcium is stored that is comparable to the entire wooden body with 36% of the total share. Leaving the bark within the forest ecosystem, could therefore be beneficial especially for soils with a low base saturation. Likewise, leaving bark on site can help to treat the deposition of organic acids that are released within the decomposition of softwood litter without the application of cost intensive treatments such as fertilizer or lime applications (Reif et al. 2014).

Nevertheless, according to Heppelmann et al. (2019b) the debarking efficiency was 46% higher for summer harvesting operations as compared to winter operations. In summer operations, up to 90% of the nutrients stored within the bark

were hence left within the forest whereas only 35% to 56% remained in the forest during winter operations. Considering the nutrient supply, debarking efficiency should be improved for winter harvesting operations in order to increase the influence on the nutrient supply of the remaining forest stand.

To support the resorption of the stored nutrients by the forest stand, it could be beneficial if the bark was distributed over a larger area. Within the field tests of the debarking head prototypes discussed in Heppelmann et al. (2019b), the bark was accumulated in small-dimension piles, located wherever the operator processed the tree. By default, those bark piles were mostly located beside the machine operating trails, but in some instances also on the trail itself. To distribute the bark over a larger area and especially further into the forest stand (within the leave strip), bark piles could be collected by the forwarder during the last machine pass on a respective trail and coarsely spread within the stand, while considering the reach of the boom and grapple. This technique would need further evaluation to determine an equilibrium between the benefits of leaving nutrients on site versus the reduction in forwarding productivity. However, perhaps bark redistribution is not necessary since Borchert et al. (2015) reported that the nutrients concentrated within the machine operating trail are naturally redistributed beyond the trail.

#### *4.3.2. Influences on the spruce bark beetle population through debarking of infested trees*

The spread of the spruce bark beetle (*Ips typographus* L.) is an expanding threat for central European forests and poses new challenges towards harvesting procedures (Carrol et al. 2017; De Groot et al. 2019; Hinze et al. 2019). Debarking or bark scratching is known to be a suitable method to reduce the threat of an

expanding bark beetle infestation and to lower the risk originating from freshly harvested logs or wind-throws (Forster et al. 2003; Wermelinger 2004; Thorn et al. 2016). According to Wermelinger (2004), mechanical debarking can cause a mortality rate of 93% and debarked logs can no longer serve as breeding habitat when stored for long times within the forest.

Harvester-based debarking is expected to provide similar mortality rates. This assumption is supported by an associated study that was done by Rosnau investigating the mortality rate of spruce bark beetle caused by conventional (spiked) feed rollers (Debarking Head I 2018). Rosnau reported that the mortality rate of spruce bark beetles was at 47% within the track of the feeding rollers. Considering the higher surface contact of the bars attached on the debarking rollers (Figure 6) and a larger compressed area due to the multiple feed runs (pass-overs) and the rotation of the stem, a high mortality rate seems plausible.

Spruce bark beetles within a juvenile stage will further die from the lack of humidity necessary for their development and are frequently used as prey for various species including wasps. This predator-prey relationship between wasps (*Vespinae*) and spruce bark beetles was recorded during the S2 summer test performed in a severely infested Norway spruce stand (Figure 20). The relationship is largely based on the fact that debarking negates the natural safe zone of the bark by exposing the beetles and larvae to predators. Presumably, this effect hinges on the presence of wasp-populations and should not be relied upon for generalization.





**Figure 20:** Recorded predator-pray relationship of feeding wasps on spruce bark beetle larvae after debarking during the S2 summer tests

#### 4.3.3. *Effects on cargo load and load safety of debarked logs*

As presented in Heppelmann et al. (2019c), both static and sliding frictions of the debarked treatments were lower compared to the bark treatment during the first six days after debarking. After a longer drying period, significant differences in static and sliding frictions were no longer present. On average, the sliding frictions of the bark and debarked treatments were 24% and 33% lower than the static frictions. This resulted in an average 8.3 N/kg for the static and 5.6 N/kg for the sliding frictions for debarked roundwood, results that are supported by Baas et al. (2004). This New Zealand study investigated load and friction characteristics of debarked roundwood loads, testing different loading variables such as restrain type or tension method and the influence of break tests and tilt angles on load safety. In addition, comparable static and sliding friction pulling tests were completed and illustrated similar results and findings supporting the conclusions drawn by

Heppelmann et al. (2019c) regarding load safety issues for German logistic operations. However, when considering load safety, the sliding friction becomes the important value as safety calculations always considers the lowest safety factor.

A high static friction might be negated by vibrations or load disturbances and therefore has to be disqualified as safety calculation factor. This indicates that based on the circumstances within this study of single log storage, cold and windy weather and a drying period greater than seven days, appeared to be sufficient to assure comparable safety values of debarked logs to those of bark logs. A note of caution remains necessary as the performance of static and sliding frictions is highly dependent on climatic conditions present at the storing site. Therefore, based on the carried out investigations, a defined drying period prior to transportation cannot be given and additional load security actions should always be considered.

Besides the differences between the static and sliding frictions of the bark and debarked treatments, differences within the drying rate were also detected. Based on the measured 45% faster drying rate of debarked roundwood, further impacts on load volume and mass were calculated for two different truck and trailer combinations (Figure 18). As presented within Heppelmann et al. (2019c), this higher drying rate resulted within a 2.2% and 6.8% additional load of debarked logs after seven and 21 days and a 4.4% and 10.5% lower total load mass for Truck/Trailer combination A (Table 11). Due to the greater loading capacity of the Truck/Trailer combination B, the higher drying rate resulted in a 7% additional load at equal load mass for day 7 and an 11% additional load with 6.9% lower total load mass for day 21. All calculations referred to a full load of bark logs exposed to equal drying times.

However, barked logs, that are infested with spruce bark beetles, have to be transported out of the forest within the first seven days, while debarked logs can be stored longer without posing a threat to the remaining forest stand. For this reason, if a load of debarked logs transported after a drying period of 21 days is considered comparable to a load of barked logs after seven days, the higher drying rate results in an additional 28% of load volume for the long truck and trailer combination when loading the debarked assortment. This assumption is supported by Sohns (2012) who reported a mass reduction through debarking and faster drying rate of about 30%.

Through mass reduction for a respective volume of wood, debarking of roundwood could also have a considerable positive influence on the wear-off (brakes, tires, bearings, transmission, compressed air system, chassis, etc.), fuel consumption and handling, uphill/downhill drive, and cumulative ground pressure per load. Besides the wear off, fuel consumption can represent up to 30% of transportation costs (Korten and Eberhardinger 2008b). Fuel consumption reported on a liter per cubic meter basis could therefore benefit greatly from in-stand debarking, thus further decreasing the CO<sub>2</sub> footprint of roundwood logs as compared to logs with bark. Debarking could also help to lessen the strain on the current transport capacity of roundwood logs within the German forests (Korten and Eberhardinger 2008b). This situation is further stressed by the massive amount of wood that is currently harvested due to spruce bark beetle infestations and has to be removed out of the forest under very rigid and fast periods. Thanks to harvester-based in-stand debarking, wood can be stored longer in the forest without the threat of a spreading infestation and due to a higher load capacity per load, the flow of roundwood out of the German forest could be increased, while reducing the threat of crucial overloading (Koirala et al. 2017).

## 5. Study limitations and areas of improvements

The most prominent limitation and area of improvement is linked with debarking performance assessed during winter operations. The low debarking ability was likely caused by the absence of the natural dividing layer based on the sap flow within the tree. However, within tests of the S3 setup, modifications of the delimiting knives offered good results on trees that were infested with the spruce bark beetle. Spruce bark beetles have a similar effect on the sap flow than the vegetation season. In a late state of infestation, the bark beetle larvae could completely interrupt sap flow. In these instances, the dividing layer was not present, but the S3 setup was able to provide good debarking results with a very low variance (Figure 15). Based on these experiences, the most promising attempt would be to further modify the knives if a higher debarking percentage is to be achieved during future winter operations.

Due to the novelty and early stage of the measurement system, limitations and areas of improvements were discovered during the laboratory tests and in-field application. The first improvement is linked with precision and bias. For setting a benchmark of debarking results originating from harvesting head modifications the system proved to be sufficient. However, if more detailed investigations of debarking effects and especially influencing factors of single modifications are to be assessed, a higher resolution and precision could be beneficial to provide more detailed results.

Certain improvements with the debarking measurement system could also be warranted. With a single image per log captured by a reflex camera, a maximum share of 50% of the surface was recorded. The assumption of the blind-side, with the same debarking percentage according to the recorded part of the stem is likely causing the most failures and is responsible for the limited use of single log debarking percentage on the assessment of single physical influences factors such as branchiness, curvature, or taper.

Two methods of solving the issue are plausible. First, by taking a second picture from the backside of the log the recorded area can be expanded accordingly. However, due to the angle of view, overlapping areas from the two pictures originating from the same log can be problematic. Second, by replacing the photo-optical recording device by a terrestrial LiDAR, up to a 100 percent of the surface could be recorded without any overlapping as multiple scans can be merged within the software producing one 3D model of the recorded log. The recorded 3D surface could be unrolled from a cylindrical into a flat projection and displayed as a 2D pattern, solving also the distortion issues previously mentioned (3D measurement within a 2D display). Both of these options would require the log to be turned between measurement acquisitions.

The recognition and application of the polygons could also be improved during future upgrades of the Stemsurf software. This would decrease the processing time, which would allow for larger sample sizes to be evaluated. In this context, a semi-automized pattern recognition based on the shape and color (RGB) seems feasible, especially in combination with a LiDAR recording device. Similar attempts for automated pattern recognition based on the RGB color data have been investigated by Weidenhiller and Denzler (2014) but showed certain limitations. Within the study performed by Weidenhiller and Denzler (2014), the accuracy never exceeded

60% due to high shares of unknown areas within the software algorithm when defining bark and wood patterns only based on the color. Weidenhiller and Denzler (2014) are also certain that a pattern recognition only based on color will never perform to a satisfying level, due to countless atypical bark colors that can appear within the natural color scheme. Impurities in the form of dirt or litter residuals can further impede the automated recognition. A combined automated pattern recognition based on the RGB color value and roughness of the surface (3D information) seems therefore most promising for future improvements.

## 6. Conclusions

Within the presented research, the possibility of adding debarking as part of the mechanized harvesting process was tested and analyzed by modifying harvesting heads with existing parts of related Eucalyptus debarking heads. The main findings were:

- Modifications of the three tested harvesting heads resulted in high debarking percentages of 73% to 91% in summertime.
- The absence of the sap flow and therefore of the important dividing layer between wood and bark, decreased the effectiveness of the tested systems by 35% and 54% during winter operations.
- The measurement system used to quantify debarking percentage proved its applicability and delivered very robust results with standard deviations lower than the expected 5%.
- By adding further recording devices that are based on LiDAR, the accuracy of the measurement system could be improved for future applications and larger scaled test setups.
- Debarked logs proved to provide lower static sliding frictions compared to bark logs.
- Debarking proved to have a significant influence on the drying rate and therefore increasing the maximum load capacity on existing truck and trailer systems, while decreasing the total load mass. Specifically, debarked roundwood could allow additional load capacities of up to 28% when compared to truck loads of conventional assortments.

Based on the main findings it can be concluded that within the tested parameters the strongest influencing factor on the debarking percentage was harvesting season with decreased debarking efficiency within winter harvesting operations. This effect becomes neutralized when applied in spruce bark beetle treatments, as these operations are usually executed within the summer harvesting season and the prototypes tested had strong debarking performance even with infested logs. However, if in-stand debarking is to be applied with a goal of maintaining bark nutrients in the stand then further modifications and testing during winter operations is warranted to increase the performance.

Overall, it must be stated that harvester-based in-stand debarking offers a high potential for improving economic and ecological factors of the future roundwood procurement, while addressing challenges threatening current sustainable forest management processes and techniques within a central European context.



## 7. Additional experiences gained through the PhD project

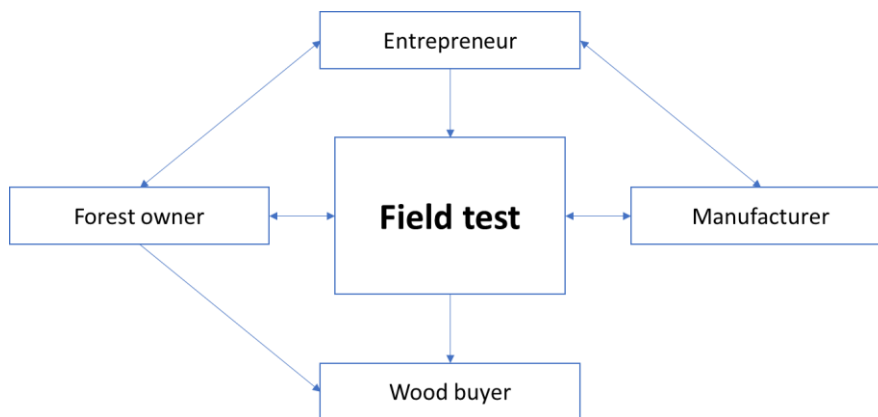
### *7.1. Project management and field test organization*

A major part of the PhD project was focused on the organization and management of associated field tests. This task was complicated since it involved multiple stakeholders requiring simultaneous coordination. The involved parties included:

- Forest owners (State forests)
  - Foresters
  - Forest workers
- Manufacturers of harvesting equipment (John Deere, LogMax, Ponsse)
  - Engineers and mechanics
- Forest entrepreneurs (Raker; Harrer&Mayer)
  - Harvester/Forwarder operators
- Wood purchasers

For the tests, suitable forest stands that met the test requirements had to be identified and the permission of the forest owners to allow debarking within the harvesting process needed to be obtained. At times, this posed some issues as forest owners were not able to include debarked assortments into pre-existing contracts with the current wood purchasers. Therefore, a close cooperation with the lower Saxonian and Bavarian State forests developed, and all field trials were performed within the state ownership. Forest entrepreneurs owning the targeted harvesters and willing to test the new modifications on their machines had to be found.

Furthermore, the entrepreneur had to be accepted by the forest owner or already have existing contracts with the forest owners, which further limited the pool of potential candidates. Lastly, the harvesting head had to be modifiable with the parts sent by the respective manufacturing companies. Due to the lack of project funds, modification kits were generously provided at no cost by the manufacturers. The entire logistics of harvester, operator, manufacturer was complicated and required hands-on management. These relations are illustrated within Figure 21.



**Figure 21:** Relations of the involved parties within each field-test of debarking harvesting modifications

A detailed organization and direct communication path via telephone and personal presence with the involved parties proved to be vital for the success of the project. Despite strong communications, additional decisions had to be made on-the-fly during live harvesting operations. Being responsible for those decisions and associated consequences implied strong organizational skills.

A major factor on short-term changes was the starting infestation wave of spruce bark beetles at the same time the S2 and S3 summer tests were planned. The presence of spruce bark beetle infestations complicated both stand and machine availability. Therefore, the tests had to be done within infested stands adding further potential influencing factors on the debarking percentage that had to be recorded during the harvesting operations. However, all planned and implemented tests delivered satisfying results.

## *7.2. Measurements and digitalization*

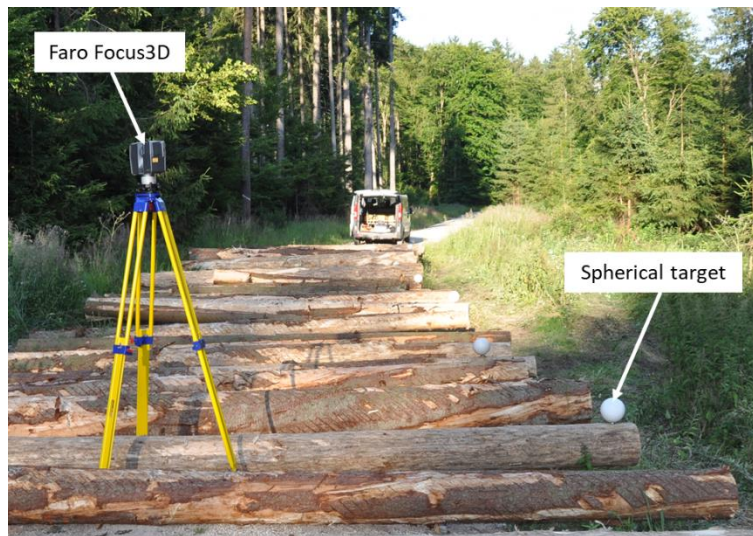
As mentioned within the limitations and area of improvements section, different recording systems could be used as input in the Stemsurf software. This knowledge was also based on experiences gained during field tests, while testing different recording devices via a Trimble V10 and a Faro (Focus3D/ TX5) terrestrial laser scanner. The Trimble V10 is a multi-camera head that carries twelve individual high-resolution cameras, enabling the V10 to take panorama shots at each position (Figure 22). In combination with the use of a total station that records each measurement position of the V10, single panorama shots were merged together to capture multi facets of logs. Therefore, both front and backside of the logs were recorded and potentially measurable. Furthermore, the system was able to calculate 3D surfaces of the logs using different pictures with different views.

The picture merging process however, turnout out to be very intricate and the created pictures could not be directly inserted within Stemsurf, without reprogramming the used algorithm. The extended use of the system was therefore abandoned, even though recording time within the field was decreased and the measured surface per logs increased.



**Figure 22:** Measurement setup of a Trimble V10, connected to total station during the S1 Summer trials

In addition to the V10, a Faro Focus3D scanner with the Trimble TX5 application was also tested during field trials (Figure 23). The Faro scanner was able to record also 360° information covering multiple logs from a single scanning position. By repositioning the scanner and using spherical targets, subsequent scans were merged together within Trimble RealWorks to large point clouds of all measured logs within a single field trial (Figure 24A).

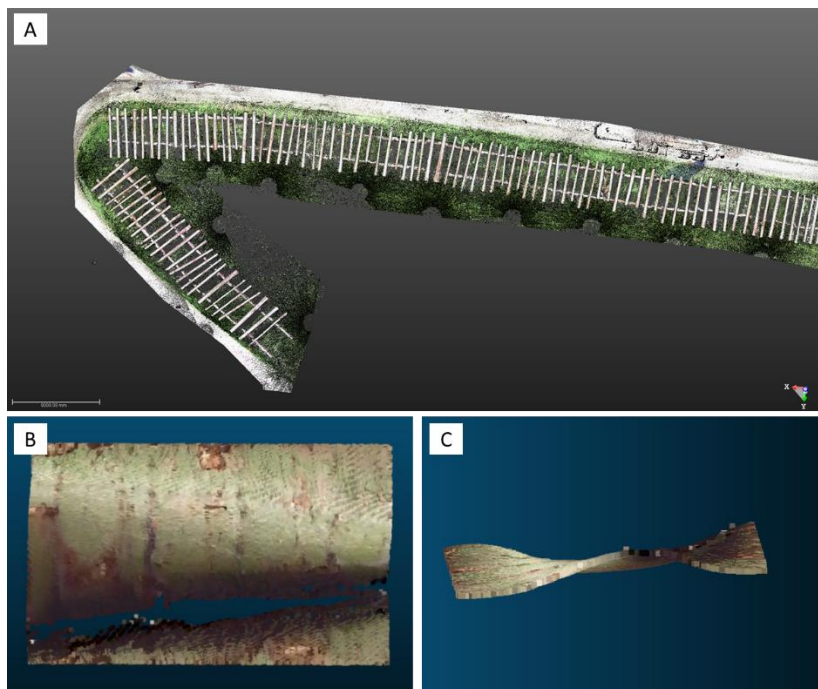


**Figure 23:** Measurement setup of the Faro Focus3D terrestrial laser scanner during the S2 summer trials

The scanning of the logs required more time than the photo-optical options (reflex camera, V10), but offered the opportunity to record more information. Using the 3D laser scans, manual measurements of the logs became obsolete as such measurements could be performed directly within the corresponding software Trimble RealWorks. Because all information was preserved and stored within the scans, users could revisit the scans at any time to recalculate different parameters, if necessary. In addition, surface information such as roughness were recorded

together with the RGB values, providing sufficient information on a future semi-automated pattern recognition for Stemsurf applications as described in the previous section (limitations and areas of improvements).

By exporting the scan information from Trimble RealWorks and importing the values into CloudCompare, an unrolling of the log surface was possible and performed for test purposes (Figure 24B). The unrolling of the logs could help solve the distortion issues of the current Stemsurf application. However, as natural logs are subjected to natural stem taper, a perfect plane projection of the surface might not be achievable without forcing the scan points into such plane while changing the defined distances between scan points and therefore potentially falsifying the information (Figure 24C).



**Figure 24:** 3D laser scans of logs within the PhD project A) Top-view of the test logs within the S3 summer test; B) Top-view of an unrolled log surface without debarking; C) Side-view of an unrolled log surface without debarking

As an addition to the Faro Focus3D, the hand-held scanner Faro Freestyle3D was also tested during live field tests (Figure 25). This scanner uses both laser and photo-optical information to create a 3D point cloud. First indoor test applications delivered very promising results. However, during the outdoor tests, uneven light conditions within a forest stand or at a forest road caused steady interferences, which were sufficiently cumbersome for the researchers to abandon the use of the device. Furthermore, the battery capacity was too low to scan greater amounts of logs in one session and the system had to be connected to an external electrical generator.



**Figure 25:** In field test applications of a Faro Freestyle3D laser scanner to record debarked Scots pine logs

Another recording method that showed promise was the employment of unmanned aerial vehicles (drones). Within the S2 Summer tests, a drone was deployed to record the debarking process from a birds-eye view providing new insights into the position of the machine within the stand during the debarking harvesting operations and recording the distribution of the remaining bark. The drone was also able to provide close-up video or still footages of the debarking head

in action without any person entering the harvester-danger radius (Figure 26A). These footages were very helpful to understand the debarking process and the interaction of the different harvesting head modifications as well as ease the explanation of the system within presentations and lectures. The birds-eye view of the aligned test logs was further considered to be tested within the Stemsurf application as a single overflight could provide the entire photo-optical information needed, but was not completed within the PhD project (Figure 26B).

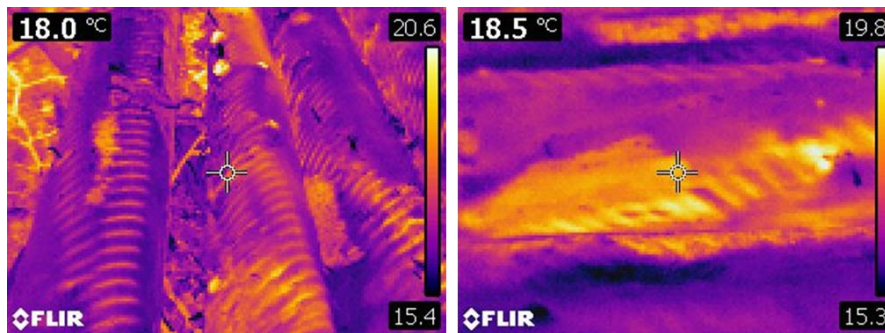


**Figure 26:** Footage recorded by a drone during the S1 summer field trials A) Debarking process of Scots pine, top and bottom view; B) Birdseye view of a debarked Scots pine log

During the S3 summer trials, a sixth recording method was tested with using a FLIR thermal camera. It was expected that bark remnants might show a different



heat signature as compared to a wet wood surface. Therefore, multiple pictures were recorded and investigated in the office (Figure 27). After analysis, no clear trend could be observed to help differentiate between bark and wood surfaces. This recording technique was not further investigated but could be part of an extended project because of its fast acquisition time.



**Figure 27:** Thermal images of debarked Norway spruce logs directly after processing

### *7.3. Dissemination of knowledge*

Beyond the peer-reviewed publications and presentations, a vital part of the PhD project rested on knowledge transfer of the latest results and findings. These interactions with stakeholders from the wood supply chain turned out to be crucial for the successful implementation of the developed modifications onto the market. Therefore, the project was presented on the KWF-trade fair in Roding (2016) and the Interforst-trade fair in Munich (2018). During these events, clear and concise explanations of the modifications and overall performance of the system were key. In addition to the exhibitions, the system was also presented on multiple occasions to potential customers and to state and national government agencies. The most prominent presentations are listed below:

**Table 12:** List of further presentations and knowledge transfer activities

Year	Title	Venue
2018	How efficient is debarking with harvesting heads? - Findings from the project "Debarking Heads I"	Presentation Day of the Department of Forestry 2018, Freising (Germany)
2018	Exhibition stand	INTERFORST, Munich (Germany)
2018	How efficient is debarking with harvesting heads? - Findings from the project "Debarking Heads I"	Forstlicher Unternehmertag, Freising (Germany)
2018	Minimizing nutrient extraction during harvesting operations - by the use of debarking harvesting heads	Spruce Bark-Beetle Seminar, Gmunden (Austria)
2017	Minimizing nutrient extraction during harvesting operations - by the use of debarking harvesting heads	Spruce Bark-Beetle Workshop, Schloss Waldreichs (Austria)
2017	Minimizing nutrient extraction during harvesting operations - by the use of debarking harvesting heads	Fachagentur für Nachhaltende Rohstoffe (FNR)-Statusseminar, Berlin (Germany)
2016	Exhibition stand and live demonstration	KWF-Tagung, Roding (Germany)
2016	Assessing the efficiency of debarking harvesting heads	2 <sup>nd</sup> HEZagrar PhD Symposium 2016, Hans Eisenmann-Zentrum, Freising (Germany)
2016	Evaluating the debarking efficiency of modified harvester heads on Central European tree species	1 <sup>st</sup> "ZWFH-Forum" 2016, Freising (Germany)

The knowledge transfer culminated in 2018 with a five-minute documentary on the local state television station BR (Bayerischer Rundfunk), which presented the debarking system to an even broader audience outside of the forest sector (Unser Land, 2018).

#### 7.4. Supervision experiences

Besides the self-conducted research, multiple bachelor level theses were conducted within the PhD project and co-supervised by the PhD Candidate. Experiences gained through student supervision helped to understand the impact of

debarking on further fields of interest that were not included within the PhD scope. A total of twelve bachelor theses were co-supervised and listed in Table 13.

**Table 13:** List of bachelor level theses co-supervised by the PhD Candidate

<b>Year</b>	<b>Author</b>	<b>Title</b>	<b>Status</b>
2019	Wei, L.	Spruce bark beetle emigration rates of bark piles following fully mechanized debarking operations	In progress
2019	Gerthofer, M.	Investigations on the mineralization rate on Norway spruce bark originating from summer debarking operations	In progress
2019	Haftner, L.	The debarking head technology: a mechanical alternative for chemical treatments within the state forest Freising	Completed
2019	Reichenberger, A.	Determination of surface frictions of debarked logs	Completed
2019	Steinacker, M.	Investigations on the mineralization rate on Norway spruce bark originating from winter debarking operations.	Completed
2018	Huber, C.	Processes within the wood industry regarding the logistic supply chain and further processing of the resulting bark leftovers	Completed
2017	Weber, S.	Determination of the debarking rate in fully mechanized conventional harvesting operations	Completed
2017	Vater, S.	Comparison of existing methods for recording stand damage caused by fully mechanized operations - Development of a recording procedure for comparing the existing damage of two harvesting methods in one stand	Completed
2017	Rosnau, F.	Influence of mechanized timber harvesting on death rate of spruce bark beetle ( <i>Ips typographus</i> ) and pine bark beetle ( <i>Pityogenes chalcographus</i> )	Completed
2017	Fangauer, J.	Remaining rate of bark-bound nutrients in the stand of fully mechanized operations with and without debarking	Completed
2016	Braun, S.	Debarking percentage of the Ponsse H8 harvesting head at normal and increased feeding pressure	Completed
2015	Leidner, W.P.	Industrial plant vs. forest - Development of round wood debarking in Germany	Completed

## References

- Baas, P.H.; Mueller, T.H.; Milliken, P., 2004. Load Security Testing of Logs A Summary Report for the Log Transport Safety Council; Transport Engineering Research New Zealand Limited: Manukau City, New Zealand.
- Baroth, R., 2005. Literature review of the latest development of wood debarking (Report A, 27).
- Baumgartner, R.; Brüchert, F.; Staudenmaier, J.; Sauter, U.-H., 2007. Bark measurements with x-ray technology. In Proceedings of the COST E 53 Conference - Quality Control for Wood and Wood Products, Warsaw, Poland, 15 - 17 October 2007.
- BaySF, 2017. Statistikband; Bayerische Staatsforsten: Regensburg, Germany; p. 30.
- Borchert, H., Huber, C., Göttlein, A., Kremer, J., 2015. Nutrient concentration on skid trails under brush mats – is a redistribution of nutrients possible. *Croatian Journal of Forest Engineering*. 32(2): 243-252 pp.
- Carroll, A.; Forster, B.; Hurling, R.; Nageleisen, L.M.; Ravn, H.P.; Weed, A.; Schroeder, M.; Grégoire, J.; Marini, L.; Økland, B.; et al., 2017. Climate drivers of bark beetle outbreak dynamics in Norway spruce forests. *Ecography*, 40, 1426-1435.
- De Groot, M.; Diaci, J.; Ogris, N., 2019. Forest management history is an important factor in bark beetle outbreaks: Lessons for the future. *Forest Ecology and Management*, 433, 467-474.
- Debarking Head I 2018. Abschlussbericht - Nährstoffentzüge bei Holzernte minimieren durch die Nutzung von entrindenden Harvesterfällköpfen (Debarking Head). Bundesministerium für Ernährung und Landwirtschaft. p. 100.

- Deutscher Wetterdienst, 2019a. Wetterlexikon, Jahreszeiten. Available online: <https://www.dwd.de/DE/service/lexikon/Functions/glossar.html?lv2=101304&lv3=101324> (last checked Sept. 2019)
- Deutscher Wetterdienst, 2019b. Wetterlexikon, Starkregen. Available online: <https://www.dwd.de/DE/service/lexikon/begriffe/S/Starkregen.html> (last checked Sept. 2019)
- Eggers, J.R., 2010. *Acacia mearnsii* debarking: comparing different debarking technologies in the KwaZulu-Natal and Mpumalanga forestry regions of South Africa. Nelson Mandela Metropolitan University, 175 pp.
- Filbakk, T., Jirjis, R., Nurmi, J., Høibø, O., 2011. The effect of bark content on quality parameters of Scots pine (*Pinus sylvestris* L.) pellets. *Biomass and Bioenergy*, 35(8), 3342-3349.
- Forster, B., Meier, F. and Gall, R., 2003. Bark beetle management after a mass attack - some Swiss experiences. In: McManus, Michael L.; Liebhold, Andrew M., eds. *Proceedings: Ecology, Survey and Management of Forest Insects; 2002 September 1-5; Krakow, Poland*. Gen. Tech. Rep. NE-311. Newtown Square, PA: US Dept. of Agriculture, Forest Service, Northeastern Research Station. 10-15 pp.
- Gerasimov, Y., Karjalainen, T., 2006. Development of wood procurement in Northwest Russia: round wood balance and unreported flows. *European Journal of Forest Research* 125 (2): 189-199 pp.
- German Federal Ministry of Transport and Digital Infrastructure 2019. Schedule of Fines and Penalties. Available online: <https://www.bussgeldkatalog.org/zuladung-lkw> (accessed on 8 July 2019).
- Hauck, A.; Prüm, H.J., 2019. Debarking Head im Hunsrück - Vollmechanisierte Holzernte mit gleichzeitiger Entrindung. *FTI Forsttechnische Informationen* 71 (4): 14-15 pp.
- Hinze, J.; John, R.; Delb, H., 2017. Spreading Dynamics of the European Spruce Bark Beetle in the Black Forest National Park; FVA Annual Report; Forest Research Institute: Freiburg, Germany; 28-29 pp.

- Hopmans, P.; Stewart, H.T.L.; Flinn, D.W., 1993. Impacts of harvesting on nutrients in a eucalypt ecosystem in southeastern Australia. *Forest Ecology and Management* 59 (1–2): 29-51 pp.
- Kaltschmitt, M.; Hartmann, H.; Hofbauer, H., 2009: *Energie aus Biomasse - Grundlagen, Techniken und Verfahren*. 2. Auflage. Heidelberg, Dordrecht, London New York: Springer Verlag.
- Koirala, A.; Kizha, A.R.; Roth, B.E., 2017. Perceiving Major Problems in Forest Products Transportation by Trucks and Trailers: A Cross-sectional Survey. *European Journal of Forest Engineering*, 3, 23-34 pp.
- Korten, S.; Eberhardinger, A., 2008a. Entwicklungen für den Rundholztransport. *Logistik - Holz kommt in Fahrt*, LWF Aktuell 2008; Bavarian State Institute of Forestry: Freising, Germany, 2008; Volume 65, pp. 16-18 pp.
- Korten, S.; Eberhardinger, A., 2008b. Mehr Effizienz im Rundholztransport. *LWF aktuell 2008*; Bavarian State Institute of Forestry: Freising, Germany, 2008; Volume 65, pp. 12 - 13. ISSN 1435-4098.
- Kupferschmid, A., 2001. *Holzkunde II Teil 4, Rindenkunde und Rindenverwertung*, Research Collection ETH Zürich. Permanent Link: <https://doi.org/10.3929/ethz-a-004536640>
- Labelle, E.R., Breinig, L.; Spinelli, R., 2019. Extent and severity of damages caused to spruce roundwood by harvesting heads in standard versus debarking configurations. *European Journal of Forest Research*, 138(1), 151-163 pp.
- Lehtikangas, P., 2001. Quality properties of pelletised sawdust, logging residues and bark. *Biomass and bioenergy*, 2001, 20. Jg., Nr. 5, 351-360 pp.
- Magagnotti, N., Nati, C., Pari, L., Spinelli, R., Visser, R., 2011. Assessing the cost of stump-site debarking in eucalypt plantations. *Biosystems Engineering*, 110 (4), 443-449 pp.
- Nieminen, M., Laiho, R., Sarkkola, S., Penttilä, T., 2016. Whole-tree, stem-only, and stump harvesting impacts on site nutrient capital of a Norway spruce-dominated peatland forest. *Eur J Forest Res* 135 (3): 531-538 pp. DOI: 10.1007/s10342-016-0951-1.

- Payn, T., Carnus, J.M., Freer-Smith, P., Kimberley, M., Kollert, W., Liu, S., Orazio, C., Rodriguez, L., Silva, L.N. and Wingfield, M.J., 2015. Changes in planted forests and future global implications. *Forest Ecology and Management*, 352, 57-67 pp.
- Pohjonen, V.; Pukkala, T., 1990. Eucalyptus globulus in Ethiopian forestry. *Forest Ecology and Management*, 36(1), 19-31 pp.
- Quartucci, F., Schweier, J.; Jaeger, D., 2015. Environmental analysis of Eucalyptus timber production from short rotation forestry in Brazil. *International journal of forest engineering*, 26(3), 225-239 pp.
- Reif, A., Schulze, E-D., Ewald, J., Rothe, A., 2014. Forest liming – soil protection versus nature conservation? *Forest Ecology, Landscape Research and Nature Conservation*. 14: 5-29 pp.
- Reisinger, K.; Höldrich, A.; Kuptz, D.; Hartmann, H. Poster: Umrechnungsfaktoren verschiedener Raummaße für Scheitholz. Technologie- und Förderzentrum im Kompetenzzentrum für Nachwachsende Rohstoffe. Available online: [www.tfz.bayern.de](http://www.tfz.bayern.de) (accessed on 8 July 2019).
- Rocha, J. H. T., de Moraes Gonçalves, J. L., Gava, J. L., de Oliveira Godinho, T., Melo, E. A., Bazani, J. H.; Wichert, M. P., 2016. Forest residue maintenance increased the wood productivity of a Eucalyptus plantation over two short rotations. *Forest ecology and management*, 379, 1-10 pp.
- Sedjo, R.A., 1999. The potential of high-yield plantation forestry for meeting timber needs. In: Boyle J.R., Winjum J.K., Kavanagh K., Jensen E.C. (eds) *Planted Forests: Contributions to the Quest for Sustainable Societies*. Forestry Sciences, vol 56. Springer, Dordrecht
- Sohns, H., 2012. *Moderne Holzernte*, Stuttgart: Ulmer
- Thomas, L.; Shaffer, C.A.; Mili, L.; Thomas, E., 2007. Automated detection of severe surface defects on barked hardwood logs. *Forest Products Journal*, 57, 50-56 pp.
- Thorn, S., Bässler, C., Bußler, H., Lindenmayer, D.B., Schmidt, S., Seibold, S., Wende, B. and Müller, J., 2016. Bark-scratching of storm-felled trees preserves

- 
- biodiversity at lower economic costs compared to debarking. *Forest Ecology and Management*, 364, 10-16 pp.
- Turnbull J.W., 1999. Eucalypt plantations. In: Boyle J.R., Winjum J.K., Kavanagh K., Jensen E.C. (eds) *Planted Forests: Contributions to the Quest for Sustainable Societies*. *Forestry Sciences*, vol 56. Springer, Dordrecht
- Unser Land, 2018. *Holzernte mit Harvester: Hilft Entrinden gegen den Borkenkäfer?* Filmbeitrag, Bayerischer Rundfunk, München.
- van der Merwe, J.P., Ackerman, P., Pulkki, R.; Längin, D., 2016. The impact of mechanical log surface damage on chip size uniformity during debranching and debarking Eucalyptus pulpwood logs using a single-grip harvester. *Southern Forests: a Journal of Forest Science*, 78(2), 159-167 pp.
- Verein Deutscher Ingenieure e.V., 2011. *Securing of loads on road vehicles - Determination of coefficients of friction*. VDI 2700, Part 14; Beuth Verlag: Berlin, Germany; 20p.
- Weidenhiller, A.; Denzler, J.K., 2014. On the suitability of colour and texture analysis for detecting the presence of bark on a log. *Computers and Electronics in Agriculture*, 106, 42-48 pp.
- Weis, W., Göttlein, A., 2012. *Nährstoffnachhaltige Biomassennutzung*. *LWF aktuell* (90): 44-47 pp.
- Werkelin, J., Skrifvars, B-J., Hupa, M., 2005. Ash-forming elements in four Scandinavian wood species. Part 1: Summer harvest. *Biomass and Bioenergy*. 29 (6): 451-466 pp.
- Wermelinger, B., 2004. Ecology and management of the spruce bark beetle *Ips typographus* - a review of recent research. *Forest ecology and management*, 202(1-3), 67-82 pp.



## III. Appendices

# Appendix I

## Eidesstattliche Erklärung

Ich erkläre an Eides statt, dass ich die bei der promotionsführenden Einrichtung  
TUM School of Life Science

der TUM zur Promotionsprüfung vorgelegte Arbeit mit dem Titel:

Modifying conventional harvesting heads: a technical approach to in-stand debarking under central European conditions

in der Studienfakultät Forstwissenschaft und Ressourcenmanagement

Fakultät, Institut, Lehrstuhl, Klinik, Krankenhaus, Abteilung

unter der Anleitung und Betreuung durch: Prof. Dr. Eric R. Labelle ohne sonstige Hilfe erstellt und bei der Abfassung nur die gemäß § 6 Ab. 6 und 7 Satz 2 angebotenen Hilfsmittel benutzt habe.

Ich habe keine Organisation eingeschaltet, die gegen Entgelt Betreuerinnen und Betreuer für die Anfertigung von Dissertationen sucht, oder die mir obliegenden Pflichten hinsichtlich der Prüfungsleistungen für mich ganz oder teilweise erledigt.

Ich habe die Dissertation in dieser oder ähnlicher Form in keinem anderen Prüfungsverfahren als Prüfungsleistung vorgelegt.

Die vollständige Dissertation wurde in \_\_\_\_\_  
veröffentlicht. Die promotionsführende Einrichtung

\_\_\_\_\_ hat der Veröffentlichung zugestimmt.

Ich habe den angestrebten Doktorgrad noch nicht erworben und bin nicht in einem früheren Promotionsverfahren für den angestrebten Doktorgrad endgültig gescheitert.

Ich habe bereits am \_\_\_\_\_ bei der Fakultät für \_\_\_\_\_

\_\_\_\_\_ der Hochschule \_\_\_\_\_

unter Vorlage einer Dissertation mit dem Thema \_\_\_\_\_

\_\_\_\_\_ die Zulassung zur Promotion beantragt mit dem Ergebnis: \_\_\_\_\_

Die öffentlich zugängliche Promotionsordnung der TUM ist mir bekannt, insbesondere habe ich die Bedeutung von § 28 (Nichtigkeit der Promotion) und § 29 (Entzug des Doktorgrades) zur Kenntnis genommen. Ich bin mir der Konsequenzen einer falschen Eidesstattlichen Erklärung bewusst.

Mit der Aufnahme meiner personenbezogenen Daten in die Alumni-Datei bei der TUM bin ich

einverstanden,  nicht einverstanden.

Steinkjer, 20.05.2020,

Ort, Datum, Unterschrift



## Appendix II

Development and validation of a photo-based measurement system to calculate the debarking percentages of processed logs

Heppelmann et al. 2019a

Article

# Development and Validation of a Photo-Based Measurement System to Calculate the Debarking Percentages of Processed Logs

Joachim B. Heppelmann <sup>1,2,\*</sup>, Eric R. Labelle <sup>2,\*</sup> , Thomas Seifert <sup>3,4</sup> , Stefan Seifert <sup>3</sup> and Stefan Wittkopf <sup>1</sup>

<sup>1</sup> University of Applied Science Weihenstephan-Triesdorf, Hans-Carl-von-Carlowitz-Platz 3, D-85354 Freising, Germany; stefan.wittkopf@hswt.de

<sup>2</sup> Assistant Professorship of Forest Operations, Department of Ecology and Ecosystem Management, Technical University of Munich, Hans-Carl-von-Carlowitz-Platz 2, D-85354 Freising, Germany

<sup>3</sup> Scientes Mondium UG, Ruppertskirchen 5, D-85250 Altomünster, Germany; seifert@sun.ac.za (T.S.); s.seifert@scimond.de (S.S.)

<sup>4</sup> Department of Forest and Wood Science, Stellenbosch University, Private Bag X1, 7602 Matieland, South Africa

\* Correspondence: joachim.heppelmann@hswt.de (J.B.H.); eric.labelle@tum.de (E.R.L.); Tel.: +49-8161-71-5898 (J.B.H.); +49-8161-71-4760 (E.R.L.)

Received: 29 March 2019; Accepted: 10 May 2019; Published: 12 May 2019



**Abstract:** Within a research project investigating the applicability and performance of modified harvesting heads used during the debarking of coniferous tree species, the actual debarking percentage of processed logs needed to be evaluated. Therefore, a computer-based photo-optical measurement system (Stemsurf) designed to assess the debarking percentage recorded in the field was developed, tested under laboratory conditions, and applied in live field operations. In total, 1720 processed logs of coniferous species from modified harvesting heads were recorded and analyzed within Stemsurf. With a single log image as the input, the overall debarking percentage was calculated by further estimating the un-displayed part of the log surface by defining polygons representing the differently debarked areas of the log surface. To assess the precision and bias of the developed measurement system, 480 images were captured under laboratory conditions on an artificial log with defined surface polygons. Within the laboratory test, the standard deviation of average debarking percentages remained within a 4% variation. A positive bias of 6.7% was caused by distortion and perspective effects. This resulted in an average underestimation of 1.1% for the summer debarking percentages gathered from field operations. The software generally performed as anticipated through field and lab testing and offered a suitable alternative of assessing stem debarking percentage, a task that should increase in importance as more operations are targeting debarked products.

**Keywords:** debarking harvesting heads; biomass; photo-optical measurements; forest operations; software; remote sensing

## 1. Introduction

Remote sensing technologies play an important role as nondestructive tools used to evaluate numerous scientific questions and approaches. Within a forestry context, much development has occurred in the last two decades where airborne or even spaceborne data are utilized to evaluate canopy structures [1], crown characteristics [2–4], and above-ground biomass itself [5,6]. However, due to the nondestructive nature, terrestrial optical remote sensing technologies are also increasingly

used to measure forest characteristics such as sub-canopy architecture [7], leaf area index [8–10], tree height, diameter at breast height [11–18] or even above-ground stump geometry [19].

In addition to tree morphology and stand structure, optical measurement systems are increasingly used for detailed investigations of the resulting forest products. Such radioscopic and nondestructive measurement systems (flat X-ray, CT scanners, laser, or photo-optical systems) are normally positioned at the in-feed of debarking facilities or the first manufacturing line within an industrial plant to search for beneficial or undesirable log characteristics such as resin pockets, branches, cracks, impurities, and foreign bodies [20–22]. For example, the images can be used to increase the yield and marginable profit by pre-calculating the cutting sequence within sawmills [21,23,24]. Concerning bark measurements, the systems are able to provide additional bark information, such as the debarking percentage and absolute and relative bark volumes in comparison to the total stem volume [25,26]. The systems mentioned above have all been tested and generally perform very well. However, because of their location at an industrial plant, they do not allow for measurements to be recorded directly in the forest. This precondition was a requirement for our project, since the aim was to assess the debarking efficiency of modified harvesting heads during live forest operations. Such harvesting heads are used in mechanized forest operations to fell, delimb, and process trees into assortments of varying lengths.

More specifically, technologies developed for harvesting operations in *Eucalyptus* sp. plantations in South Africa, South America, Australia, and so forth were transferred and tested under central European conditions. Therefore, conventionally used harvesting heads were modified with parts originally designed for Eucalyptus operations. Conventional debarking measurement procedures for in-field use, such as the trans-line intersect measurement procedure [27,28], were considered but were determined to be too inaccurate to assess a high volume of wood. The net measurement method, where nets with defined square areas are used and then knots are counted that lie on bark or wooden areas of a log to calculate the debarking percentage, was also tested in a pilot study. However, the method proved to be too time consuming and was therefore not further pursued. For a higher accuracy and precision, the utilization of complex but precise facility-based measurement systems (CT, X-ray, laser) was also under review. However, a research approach relying on industry-based radioscopic systems was not feasible, as the measurements had to be embedded into the ongoing harvesting operations with a minimum of interference. Furthermore, the diverse wood assortments in Germany are usually sold to different industrial customers and are therefore sorted directly after harvesting and could not be measured at a single processing facility with radioscopic systems. It was of primary interest to evaluate the whole tree and all resulting assortments after mechanized processing to evaluate the influence of log diameter and tree structure on the debarking efficiency.

Based on the specific test requirements—(i) high accuracy over a medium to high sample size, (ii) easy and fast execution of in-field measurements, (iii) operability within ongoing harvesting operations between the harvesting and the stacking of the logs—no suitable measurement system was available on the market. Therefore, the objective of this study was to develop a photo-optical measurement system designed to quantify the debarking percentage of processed logs and to assess its performance under laboratory and field conditions.

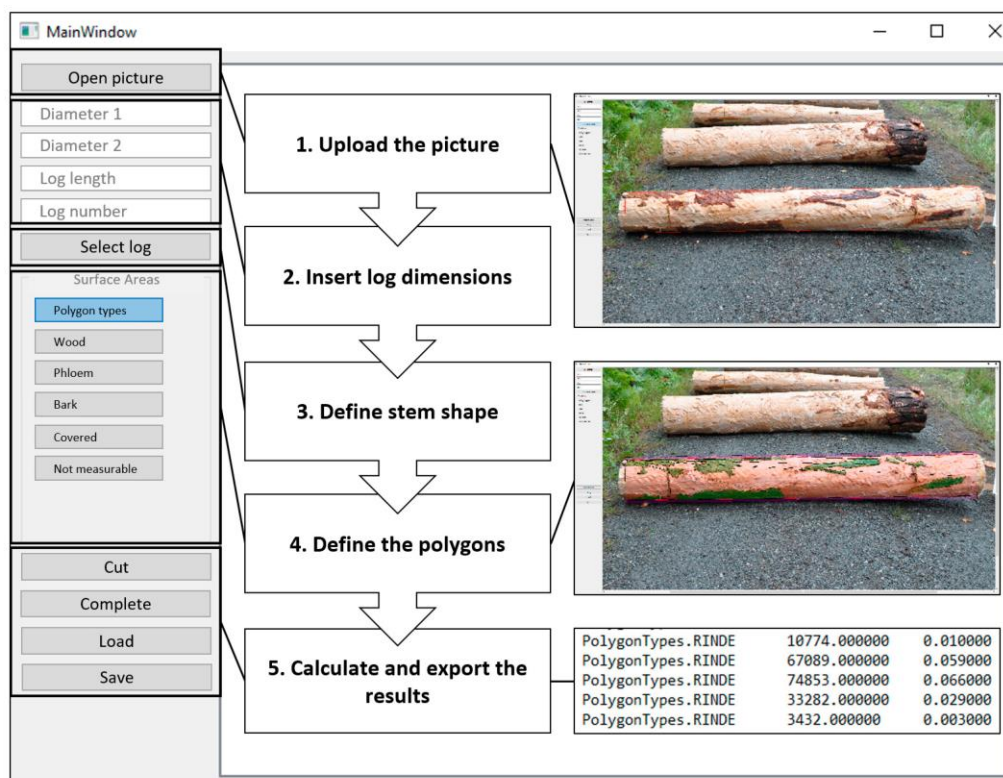
## 2. Materials and Methods

### 2.1. Development and Programming of the Measurement System Stemsurf

Measuring the remaining bark on the stems is tedious in the field. Thus, the photogrammetric software solution "Stemsurf" was developed by the company Scientes Mondium UG, to facilitate an efficient and objective measurement of residual bark (phellem) and phloem. Stemsurf allows to mark and measure the remaining bark in an image. For this, images were taken of the stems with a standard digital single-lens reflex (DSLR) camera. Additionally, log diameters at the small and large ends as well as the length were measured to provide a reasonable base for the ensuing image transformation. This process is a re-projection of manually drawn polygons on a series of frustums, which represent the

log. It is done under the assumption that a log has a circular cross-section and that the camera distance compared to the log diameter is far away, so a nearly parallel projection of the log can be assumed. The process makes use of the human ability of pattern recognition.

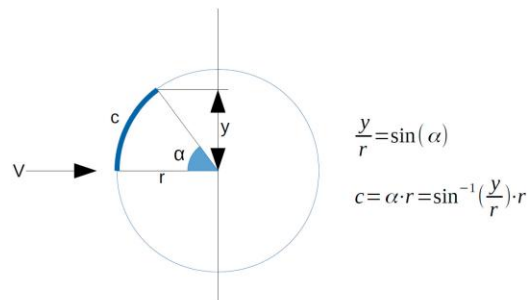
The first task of the user is to mark the stem in the image by defining the stem ends and providing the diameter variation in the stem from the empirically determined stem end diameters (Figure 1). It is possible to subdivide the stem further in a set of stem axis-aligned cone frustums to describe the stem form in a more detailed way. With this procedure, the position and form of the log are located in the image. Afterwards, the user draws polygons manually around all remaining bark and phloem patches in the original image. Areas, which are occluded or otherwise not clearly visible in the image can be highlighted and then excluded in the following process. Through this method, the entire stem image is divided into different categories. The areas of the visible part of the total log and the areas of the bark or phloem patches are then calculated by the Stemsurf software. Possible overlaps of the polygons are removed automatically. In addition, a small area consisting of two adjacent pixels located around the perimeter of the stem is automatically marked as “not measurable” to prevent high projection errors due to the tangential view.



**Figure 1.** Schematic chart of the operating principle and working steps for the Stemsurf software.

All polygon vertices were projected to a flat plane applying an approximate cone unwrapping algorithm that maps the log surface to a flat plane (Figure 2). This unwrapping procedure makes use of the user-defined stem shape. First, the stem section (cone frustum) in which the vertex of interest is located is determined. Second, the stem radius ( $r$ ) in pixels is calculated based on the rule of proportions. Third, the perpendicular pixel distance from the stem axis in the image ( $y$ ) at this point is calculated using a point-line distance formula [29]. In a fourth step the vertex coordinates are unwrapped from the image space to a flat plane. In this step, the length of the circular arc  $c$  has to

be determined by the equation  $c = \arcsin\left(\frac{y}{r}\right) * r$ , where  $r$  denotes the radius at the y-stem axis cross-section in meters and  $y$  denotes the perpendicular distance from the stem axis in the image. The position along the stem axis as  $x$  coordinate together with  $c$  as the  $y$  coordinate results in the new coordinate in a flat plane.

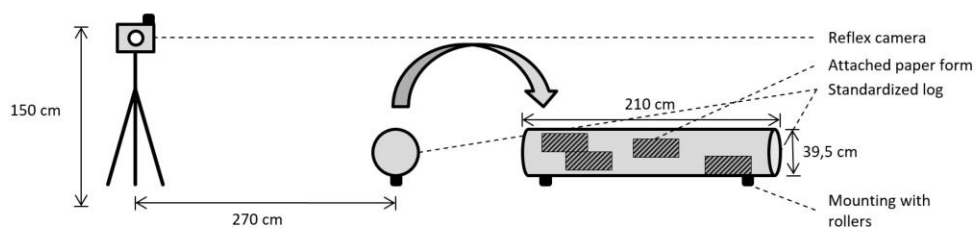


**Figure 2.** Cross-sectional view of the stem for the calculation of the bark surface area units with  $V$  being the camera view direction,  $r$  the radius at the y-stem axis cross section,  $c$  the length of the stem surface,  $\alpha$  the angle in radiant, and  $y$  the perpendicular distance from the stem axis in the image.

The pixel coordinates are then rescaled to meters based on the stem lengths and diameters measured in the field and marked in the image. The wrapped polygon area is converted to square meters accordingly. The proportions of the individual bark category to the entire visible stem area are then calculated. The proportions determined for the visible stem part are assumed to represent the entire stem accordingly.

## 2.2. Precision Validation through Lab Experience

To validate the precision of the measurements taken with the developed software, tests were performed under laboratory conditions. Within those tests, defined paper geometries simulating areas with bark residues were positioned on an artificial log. The test log was a standardized wood-log (debranching simulator for chainsaw-based debranching) without any taper or deviation on the log surface, measuring 210 cm in length with a diameter of 39.5 cm (surface area of 26,060 cm<sup>2</sup>). The covered (simulated bark) area accounted for exactly 25% (6515 cm<sup>2</sup>) of the total stem surface (Figure 3). The laboratory experiment was divided into two test series to assess the influence of the geometry of bark remnants on the curvature and rounding effects within the software and the accuracy on the debarking measurements. The first test series employed rectangular paper geometries and the second test series used perfectly round paper geometries. The gathered datasets of rectangular and round geometries were treated separately to monitor differences between both geometry types. In addition, the time required by Stemsurf to delineate the polygons with the two types of geometry was recorded to determine if the geometry type influenced the processing time.



**Figure 3.** Schematic illustration showing the laboratory setup for a test series performed on square geometry. The standardized log is turned 90 degrees to show an example of square geometry.

To identify the exact positions to place the paper forms, a grid ( $7 \times 12$ ) was applied to the log, thus subdividing it into defined segments of equal area. The position of the paper forms on the stem was then chosen with a randomizing algorithm and the paper forms were attached with pins at the correct locations on the log surface. To record the photo shots, a DSLR camera (lens: 18–105 mm focal length;  $f/3.5$ – $5.6$  maximum aperture;  $76^\circ$ – $15^\circ 20'$  angle of view; 0.45 m minimum focus distance) was installed 270 cm away from the log and mounted on a tripod at a height of 1.5 m above the ground. The horizontal distance between the camera and the log was chosen to ensure the ends of the log were not too close to the image border when considering the distortion, but close enough to have a high resolution of the log on the image. For improved imaging, the auto focus function was activated, and the highest possible resolution was used ( $4288 \times 2848$ ; 12.2 Mpixel).

The log was turned  $30^\circ$  clockwise after every image to gain 12 repetitions per setup. To define the  $30^\circ$  angle, the end-surface of the standardized log was marked similar to a watch dial defining the positions 1 to 12. To ease the turning process and to fix the log on the exact same position (depending on the angle chosen), the standardized log was mounted on four rollers (Figure 3). For each test series, 12 consecutive images were captured, while rotating the log  $30^\circ$  after each image. After completing a full  $360^\circ$  rotation, the paper forms were detached and rearranged according to the new positioning provided by the randomizer. This test design resulted in 240 images taken with the rectangular geometry and 240 images with round geometry, thus totaling 480 single images.

The 480 images were imported and evaluated within the Stemsurf software and compared to the defined 75% wood and 25% bark areas. Within Stemsurf, the debarking percentage was calculated by evaluating the single image and estimating the backside of the log proportionally. The calculations and determinations of standard deviations were performed using SPSS version 24. Multiple average debarking percentages were calculated based on varying sample sizes ( $n = 240$ ; 96; 48; 24; 12). The average with the lowest samples was calculated from 12 single images, corresponding to a full rotation of a log in a single test run.

### 2.3. Field Application

The study was imbedded within a research project that assessed the debarking efficiency of modified harvesting heads under Central European conditions. Therefore, the following three different machine setups listed in Table 1 were modified and tested:

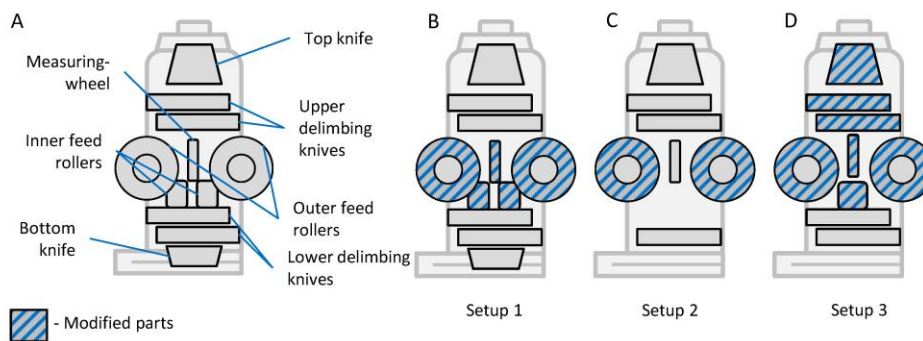
**Table 1.** Harvesters and harvesting heads studied.

	Setup 1	Setup 2	Setup 3
Harvester	John Deere 1270 E	Timberpro 620E	Ponsse ScorpionKing
Harvesting head	John Deere H480C	LogMax 7000c	Ponsse H7

Since the goal of this article is not to assess the performance of each setup but rather to verify how the software performed with logs of varying dimensions, only a concise description of the individual setups will be provided. For succinctness, the combination of harvester and harvesting head will be referred to as Setup 1 (S1), Setup 2 (S2), and Setup 3 (S3).

The focus of the research project was directed at modifying conventional harvesting heads on harvesters currently used by German forest entrepreneurs. The three harvesting heads (Table 1) tested were technically modified in order to achieve a debarking effect within the harvesting process. Modifications were performed with the support of the machine manufacturers and were limited to the use of pre-existing parts. In this regard, attempts were made to minimize the complexity of modifications in order to limit the conversion costs and were therefore mostly focused on the replacement of feed rollers. The replacement of conventional feed rollers (Figure 4) with debarking rollers (Eucalyptus rollers) forces the felled tree to rotate along its longitudinal axis within the harvesting head during the processing phase, thus allowing the delimiting knives to remove bark from the entire stem surface.

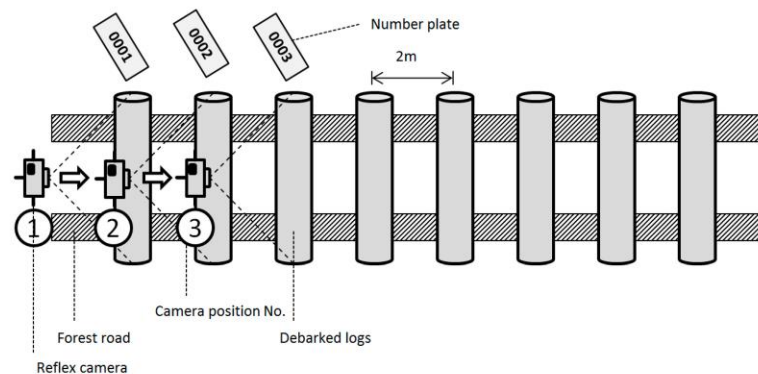




**Figure 4.** Modifications performed on three different harvesting head prototypes. (A) General overview of modifiable parts of conventional harvesting heads. (B) Tested S1 modifications (inner and outer feed rollers, measuring wheel). (C) Tested S2 modifications (feed rollers). (D) Tested S3 modifications (inner and outer feed rollers, measuring wheel, upper delimiting knives, top knife).

In the field application, a total of 1720 Norway spruce (*Picea abies* [L.] Karst) and Scots pine (*Pinus sylvestris* L.) logs, with lengths varying between 2.4 m and 5.4 m and mid-diameters ranging from 8.0 cm to 54.7 cm were measured, from stands in northern and southern Germany. To assess the influence of the associated cambial activity on debarking efficiency, 976 logs were harvested and evaluated within the vegetation season (summer) and 744 logs outside of the vegetation season (winter) according to the German Meteorological Service (DWD) (winter: from Dec 1 to Feb 28/29; summer: from June 1 to August 31).

After the trees were harvested and processed with one of the debarking head prototypes, each single log was registered and tagged with a unique number plate that was inserted into the wood at one extremity of the log. The logs were then transported to a nearby forest road or yard with a forwarder where they were then unloaded and placed in a parallel fashion perpendicular to the forest road (Figure 5). To avoid overlaps of the logs within the image, the spacing between logs was set to approximately two meters. In line with the laboratory tests, a single image was taken for each log with the same reflex camera described earlier, which was again mounted on a tripod at a height of 1.5 m. The auto focus function and the highest possible resolution were again used. To prevent shadows or blurring effects, a remote control was used to trigger the image acquisition. The images were taken only from one side (broadside) of the log, not capturing the side ends of the log. The assigned log number was recorded together with the picture number. This information was compiled and assigned in a code for every log within the database, including image number, log number, tree number, tree species, season, and harvesting head prototype. As a last working step, the small and large end diameters (0.5 cm accuracy) and the length (cm accuracy) of each log were measured manually with a caliper and measuring tape, respectively.



**Figure 5.** Schematic illustration showing the parallel positioning of processed logs placed on a forest road ready for image acquisition.

#### 2.4. Time Effort

To determine how the shape of bark remnants influenced the time required to evaluate a single log with the Stemsurf software, the average time effort was recorded for both test series. The average processing time for test logs with simple rectangular geometry was 75 seconds and thereby 143 seconds faster than for logs with a more complex round geometry (218 seconds). However, the manual evaluation of the logs in the Stemsurf software was the most time-consuming element, compared to the preparation and recording of the logs. In total, 76% of the time was allocated to evaluating the logs within the software.

### 3. Results

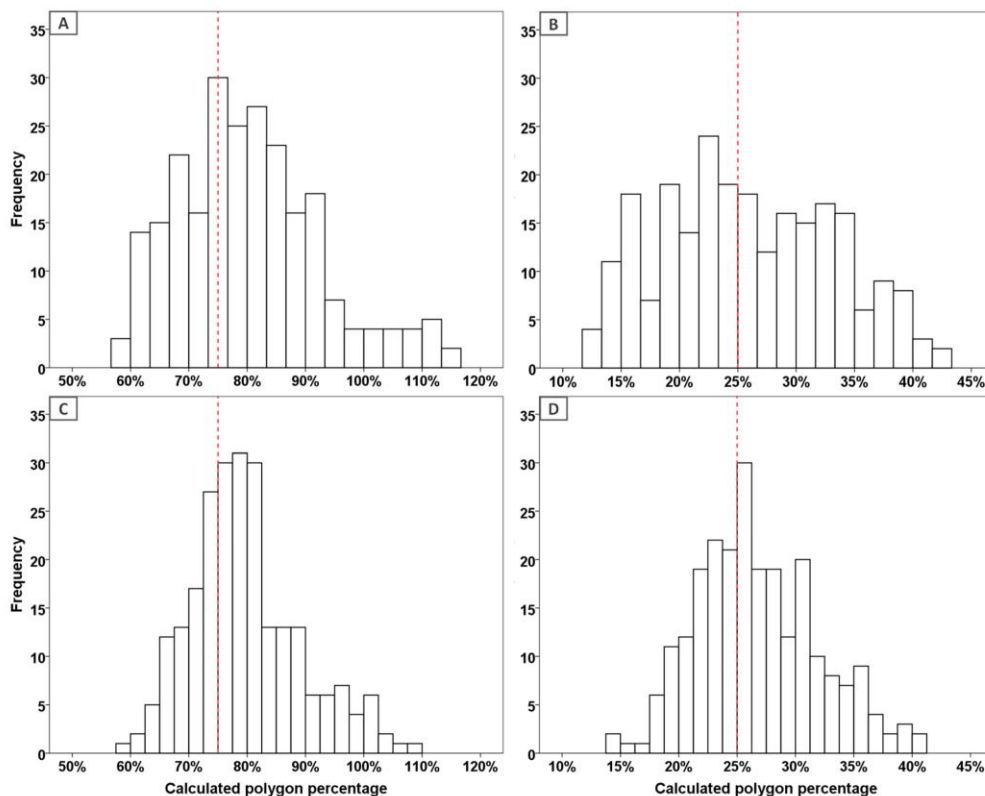
#### 3.1. Performance in Laboratory Settings

##### 3.1.1. Laboratory Precision Validation—Single Values

The 480 laboratory recordings of the simulated debarked logs revealed a broad range with the single calculated debarking percentages differing widely from the fixed 75% wood and 25% bark shares (Figure 6; Table 2). Debarking percentages did not follow a normal distribution as tested with the Kolmogorov-Smirnov and Shapiro Wilk tests. In the test series performed with rectangular geometry, a higher frequency of over- and under-calculated debarking percentages were detected compared to test series with round geometry (Figure 6). In some instances, the calculated wood surface even exceeded the total surface of the standardized log. This occurred with higher frequency for test series of rectangular geometry, causing the highest variation between the smallest and largest calculated wood surface, which was equal to a 66% difference (Figure 6A). Calculating the mean wood and bark surfaces divided into rectangular and round geometries ( $n = 240$ ), the deviation from the simulated surface exceeded the prescribed 5% for the wood surface with a 5.5% deviation for shapes with a rectangular geometry (Table 2). With a 4.8% deviation for the calculated wood surface, the test series with round geometry remained within the prescribed precision of a maximum of 5% deviation. In comparison, the calculation of the average bark surface was rather precise with deviations of 0.8% and 1.7% from the simulated 25% bark surface, for rectangular and round geometry simulations, respectively (Table 2).

**Table 2.** Descriptive statistics of the main results comparing the single debarking percentage measurement values.

Polygon	Test Series	Sample Size	Mean (%)	Standard Deviation (%)	Range (%)	Minimum (%)	Maximum (%)
Wood	Rectangular	240	80.5	12.8	66.8	56.8	123.6
	Round	240	79.6	9.4	47.8	59.9	107.7
Bark	Rectangular	240	25.8	7.6	34.8	8.4	43.2
	Round	240	26.7	5.2	26.5	14.3	40.8

**Figure 6.** Histograms of measured polygon shares of (A) wood surface of the rectangular geometry test series, (B) bark surface of the rectangular geometry test series, (C) wood surface of the round geometry test series, and (D) bark surface of the round geometry test series. The red line identifies the actual share of 75% wood and 25% bark surface.

### 3.1.2. Laboratory Precision Validation—Average Values

In a second analysis, the single polygon measurements were clustered and average wood and bark surface values were calculated to determine the deviation of average values consisting of increasing sample sizes ( $N = 12, 24, 48, 96$ ) to the actual debarking condition of 75% wood surface and 25% bark remnants. While the single measurements presented a rather wide range of minima and maxima (26.5%–66.8%; Table 2), the calculated averages only varied between 1.2% and 17.4% (Table 3). Furthermore, when combining both rectangular and round geometries, the standard deviation was accordingly lower and varied between 4.0% and 12.0% for calculated wood surfaces and 1.5% and 0.7% for calculated bark surfaces, respectively. As expected, the results showed a clear trend towards lower standard deviations of averages as the reported sample size increased. Surprisingly, the standard

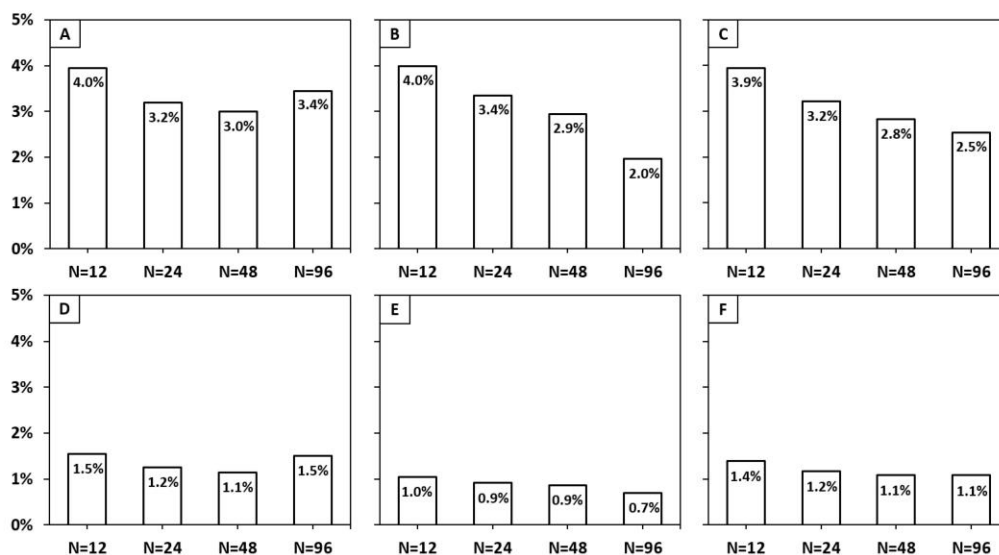
deviation calculated for the rectangular geometry test series was again higher for the larger sample size of n = 96 as compared to the round geometry test series. In most cases, the standard deviation of the more complex round geometry test series was lower compared to the simple rectangular shape test series.

However, throughout all average values of different sample sizes measured under laboratory test conditions, the standard deviation remained within the desired 5%, favoring the bark measurements with an even higher precision (Figure 7).

**Table 3.** Descriptive statistics presenting the main results comparing the calculated average debarking percentages.

Polygon	Test Series	Sample Size (%)	Standard Deviation (%)	Range (%)	Minimum (%)	Maximum (%)	Deviation Range * (%)
Wood	Rectangular	12	3.95	17.4	74.7	92.1	−0.3–17.1
	Round	12	3.98	14.5	75.3	89.9	0.3–14.9
	Rectangular	24	3.19	9.9	76.2	86.0	1.2–11.0
	Round	24	3.35	10.0	75.8	85.8	0.8–10.8
	Rectangular	48	3.00	8.0	76.3	84.2	1.3–9.2
	Round	48	2.94	6.1	77.3	83.4	2.3–8.4
	Rectangular	96	3.44	6.2	76.3	82.4	1.3–7.4
	Round	96	1.97	3.9	77.4	81.3	2.4–6.1
Bark	Rectangular	12	1.54	5.5	23.7	29.2	−1.3–4.2
	Round	12	1.05	3.5	25.8	29.2	0.8–4.2
	Rectangular	24	1.25	3.8	24.3	28.1	−0.7–3.1
	Round	24	0.91	3.2	25.8	29.0	0.8–4.0
	Rectangular	48	1.14	2.8	25.0	27.8	0–2.8
	Round	48	0.87	2.1	26.1	28.3	1.1–3.3
	Rectangular	96	1.50	2.6	25.2	27.8	0.2–2.8
	Round	96	0.69	1.2	26.1	27.3	1.1–2.3

\* Deviation of average debarking percentages from 75% for wood and 25% for bark polygon measurements under controlled conditions.



**Figure 7.** Calculated standard deviations for different sample sizes: (A) wood surface of rectangular geometry test series, (B) wood surface of round geometry test series, (C) wood surface total, (D) bark surface of rectangular geometry test series, (E) bark surface of round geometry test series, (F) bark surface total.

### 3.1.3. Laboratory Accuracy Validation—Bias

If a measurement system delivers unbiased results, the estimates of parameters  $E(\Theta)$  equals the true parameter  $\theta$ . Therefore, the difference is  $E(\Theta) - \theta = 0$ . However, if the results are biased,  $E(\Theta)$  is either greater or smaller than  $\theta$ . The parameter is then systematically overestimated if  $E(\Theta) > \theta$  (positive bias) or systematically underestimated if  $E(\Theta) < \theta$  (negative bias).

As presented in Table 4, the bias appeared to be positive for the tested estimates of parameters of  $n = 240$ , thus favoring the bark polygon measurements with a lower difference (0.8% for rectangular geometries, 1.7% for round geometries) in comparison to the difference of wood polygon measurements (5.5% for rectangular geometries, 4.6% for round geometries). Therefore, the positive bias resulted in a systematic overestimation of the measured polygon shares. However, it has to be taken into consideration that the measurements of wood polygons were based on an area that is three times larger than the bark polygon measurements. This implies also a three times higher systematic error potential for wood polygon measurements. Therefore, a relative area correction calculation was used to display the bias in a better comparability. The corrected difference between estimates of parameters ( $_{\text{Corr}}E(\Theta)$ ) and the true parameter ( $\theta$ ) accounted for 7.3% and 6.1% for wood polygons and 3.2% and 6.8% for bark polygons for square and round geometries, respectively (Table 4). When considering the 3.2% (round bark geometries) as an outlier, the average positive bias equaled 6.7% (5.9% complete dataset). Considering the applied formula for the debarking percentage where  $D$  denotes the debarking percentage,  $\text{Bark}\%$  denotes the percentage of bark residues and  $\text{Phloem}\%$  denotes the percentage of phloem residues:

$$D\% = 100\% - (\text{Bark}\% + (\text{Phloem}\% * 0.5)) \quad (1)$$

the overestimation of bark proportions lead to a systematically lower debarking percentage and the results of the summer tests should therefore be considered as rather conservative.

**Table 4.** Descriptive statistics of the calculated average debarking percentages compared to the true simulated debarking percentages of the laboratory surveys (sample size = 240).

Polygon	Test Series	$E(\Theta)$ (%)	$\theta$ (%)	$E(\Theta) - \theta$ (%)	$_{\text{Corr}}E(\Theta) - \theta$ (%)
Wood	Rectangular	80.5	75	5.5	7.3
	Round	79.6	75	4.6	6.1
Bark	Rectangular	25.8	25	0.8	3.2
	Round	26.7	25	1.7	6.8

$E(\Theta)$  - Estimates of parameters;  $\theta$  - True parameter;  $_{\text{Corr}}E(\Theta)$  - Area-corrected estimates of parameters.

### 3.2. Performance in Field Settings

Finally, based on the encouraging results of the laboratory validation tests, the method was applied in the field on 1720 logs originating from live debarking harvesting operations. As presented in Figure 7, the highest average debarking percentage (90%) was recorded during the S1 Summer II ( $n = 291$ ) test, whereas the lowest average debarking percentage (73%) of summer field trials was recorded during the S2 Summer ( $n = 242$ ) tests. Both further summer tests, S1 Summer I ( $n = 210$ ) and S3 Summer ( $n = 233$ ), performed similarly with an average debarking percentage of 84%. Considering the winter trials, the average debarking percentage varied between 35% for S2 Winter ( $n = 251$ ) and 54% for S1 Winter ( $n = 348$ ), thus equaling a 56% increase in debarking efficiency in favor of S1 Winter. S3 Winter ( $n = 144$ ) has to be considered as an intermediate test, as the sap flow was already established and performed on par with the S1 Summer II and S3 Summer tests, with a recorded average debarking percentage of 83%. Both summer and winter calculations were based on the measured bark polygon shares (Equation (1)). According to the laboratory test results of precision and bias, the debarking percentage from summer tests seemed to be systematically underestimated. Based on the debarking

percentage calculations (Equation (1)) and the bias evaluation, a corrected debarking percentage was calculated based on the equation:

$$\text{CorrD}\% = 100\% - [(Bark\% + (Phloem\% * 0.05)) - (Bark\% + (Phloem\% * 0.5)) * 0.067] \quad (2)$$

where CorrD% denotes the corrected debarking percentage, Bark% indicates the percentage of bark residues and Phloem% indicates the percentage of phloem residues.

The corrected debarking percentages are further presented in Table 5. The influence of the systematic error was considerably higher for the S1 Winter (3.1 percentage points) and S2 Winter (4.4 percentage points) test compared to the summer test series with an average difference of 1.1 percentage points. This difference is likely attributed to a greater influence of the systematic error with increasing shares of the polygon type used for the debarking percentage calculation.

**Table 5.** Measured average debarking percentages of the field application of the system corrected based on findings of the laboratory accuracy validation.

Field Tests	S1 Summer I (%)	S1 Winter (%)	S1 Summer II (%)	S2 Winter (%)	S3 Winter (%)	S2 Summer (%)	S3 Summer (%)
Debarking percentage	84.1	53.8	89.9	34.8	83.4	73.1	83.8
Corrected debarking percentage *	85.1	56.9	90.6	39.2	84.5	74.9	84.9

\* Recorded average debarking percentages of summer and winter field applications, corrected considering a bias factor.

#### 4. Discussion

In this project, a solution was presented that replaced tedious manual field measurements with a photogrammetric software that enabled the user to perform most of the work in the office based on a mathematical model of the stem and manual delineation of the different areas on the stem surface.

##### 4.1. Field and Laboratory Test Performance

The most prominent advantage of the developed measurement system lies within its simplicity. It facilitates fast and reliable measurements of debarking percentages within the forest. The measurement process can be easily fitted into the ongoing forest operations as the logs do not have to be transported to a facility to be tested by conventional measurement systems (sawmills, pulp and paper mills, etc.). Furthermore, the software allows users to record large amounts of data within a rather short time period, which can then be evaluated in a subsequent step. This reduces the time needed in the field and lowers the risk of weather influences on the test run. The use of a high-resolution reflex camera with the option for remote control is highly recommended to eliminate user errors within Stemsurf caused by a lack of contrast and sharpness of the recorded images.

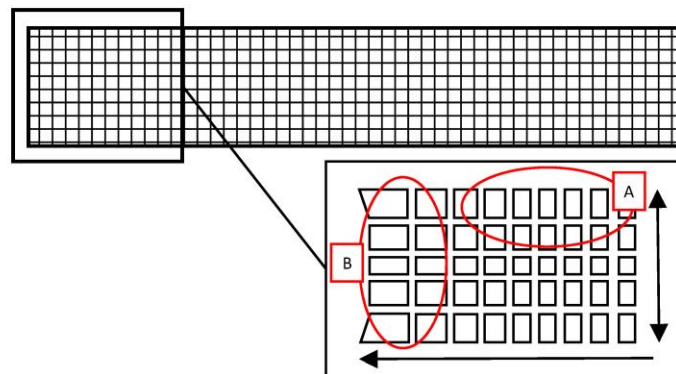
##### 4.2. Precision and Bias

The laboratory measurements presented a high variance of single debarking percentages as shown in Figure 6, mainly as a consequence of the fact that only one perspective of the log was displayed in the image and the backside of the log was estimated proportionally. However, within the debarking procedure of the harvester, the stems were rotated in a spiral direction multiple times while being fed through the harvester head. Through this rotation, the debarking was usually comparable on the entire surface of the log and caused a rather random distribution of bark residues, if the debarking percentage was not 100%. This field observation supports accurate estimations of the backside of the log on many occasions. Furthermore, taking into account that the system relied on averages over many logs rather than single log values, extreme deviations within single value measurements were less

relevant. The calculated average debarking percentages proved to be precise with both small and larger sample sizes staying within the anticipated deviation range of 5%.

Nevertheless, the occasional overestimations of summed wood surface proportions exceeded the theoretical 100% (within a margin of about 2%) and indicated areas for further improvement. Those extremes were mainly caused by rounding errors between the defined boundaries of the stem and user shortcomings within the marking of the polygons. Therefore, it is recommended that the measurements in Stemsurf are consecutively performed by the same person, to limit the variation of the user-related errors.

Another source of error was linked to polygons that extended far to the longitudinal edges and outside areas of the log, where the camera vision happened to be on a steep (tangential) angle. In such instances, the influence of different log diameters and lengths on the outside effects caused by the curvature of the log and the perspective of the camera appeared to be a potential distortion factor. Every single image was comprised of a fixed number of pixels and therefore identical pixel size. Considering the 3D reality pictured within the 2D projection of the image, a single pixel located on the stem did not represent the exact same log surface area compared to other pixels (Figure 8). Pixels located closer to the periphery of the defined log represented a larger log surface area than the pixels located in the middle (Figure 8A). This effect was caused by the curvature of the log. The effect further increased for pixels near both side-ends of the log (Figure 8B). With a distance of the camera to the log that equaled almost the length of the logs being studied in combination with the lens used (opening angle approximately 53 degrees) in the tests, a per pixel resolution of 0.0124 degrees was used. A single pixel in the middle of the log was therefore 0.6 mm wide and on the extremity 0.65 mm. This resulted in a surface deviation of  $0.65 \times \frac{0.60}{0.60^2} = 8.3\%$ . This effect can be reduced for future applications by applying a telephoto lens (90 mm), which simulates the doubling of the distance between the camera and the recorded log, thus resulting in a surface deviation at the extremities of  $0.64 \times \frac{0.62}{0.62^2} = 3.2\%$ . The deviation effects on the extremities of the log should decrease even further by locating more information to the center of the image.



**Figure 8.** Schematic of a 2D projection of a log via equal pixels and the expected described log surface with (A) longer areas towards the outside and (B) wider areas towards the extremities of the pictured log. The arrows indicate the direction of exceeding surface areas defined by a single pixel.

To limit the effect of edge distortions on the measured debarking percentage, it is also recommended to calculate the debarking percentage by relying on the smallest measured surface polygon type, since a smaller area has a potentially lower frequency of measurement failures. For measurements of logs with a high debarking percentage, a calculation based on the detected bark residues is recommended (Equation (1)). Conversely, calculations of debarked logs with a low debarking percentage should be based on wood surface polygons. The log diameter and length were equal for all test series performed in the laboratory to ensure a high comparability within the accuracy measurements and thus a potential

varying influence on distortion effects was avoided by the test setup itself. The correction calculations of the gathered field data could therefore only consider the systematic error of optical effects. Hence, the corrected debarking percentages presented in Table 5 were closer to the true parameter than prior to corrections but not exact, as some influencing factors on the bias were still unknown. These factors could not have been evaluated using the gathered field data, as the true debarking percentages were not known and therefore a true parameter  $\theta$  was not present.

Directly comparing debarking percentages measured with Stemsurf to those obtained from x-ray or laser-based technology installed at wood processing facilities was not feasible since our logs were measured in the field soon after forwarding operations had been completed. Loading the logs onto a truck and transporting them over dozens of kilometers to the closest wood processing facility, equipped with laser scanning technology, would have caused variations in debarking percentages, thus rendering the comparison irrelevant. The most relevant study we could find was performed by Baumgartner et al. [30], who manually debarked areas of rectangular geometry on logs of Norway spruce. Afterwards, the logs were scanned with an industrial scanner (Microtec Tomolog®) equipped with two x-ray sensors to determine the difference in accuracy in bark thickness between manual and scanner measurements. Baumgartner et al. [30] determined that with the x-ray scanner on average, less than half a millimeter of difference in thickness was measured from the manual reference value.

Unlike Stemsurf, light detection and ranging (LiDAR) solutions rely on contour-based detection. This causes a limitation to the identification of defects characterized by significant surface changes in height, often the case between areas of bark and wood. Defects such as knobs and depressions can therefore limit an accurate measurement of the debarking percentage [31]. Comparable limitations are not present with Stemsurf, as the detection of residues is based on a visual evaluation.

#### 4.3. Limitations and Areas of Improvements

For benchmark measurements, the precision and associated standard deviation seemed to be sufficient. However, for further investigations and if the debarking percentage needs to be improved to maximum debarking ability for live operations, the precision might need to be enhanced to monitor small changes within the debarking result with a high reliability and accuracy. Another reason to increase the accuracy and resolution will be to further investigate the influencing factors of the debarking percentage. Those research questions were not included in the main scope of the research project but could arise in the future as more operations are being performed with the debarking setups.

The simplicity of the system can also result in certain inherent limitations. By capturing and evaluating a single image per log, a maximum share of 50% of the existing surface can be recorded and measured. The remaining 50% of the surface is assumed to have the same proportions of bark areas as the measured stem part. Therefore, the individual debarking percentages should not be used to answer further questions about physical influencing factors on the debarking percentages of individual logs. Three possible solutions are conceivable to circumvent this disadvantage.

First: a larger database. If sufficient data is available, average debarking percentages of equally influenced logs can be calculated and investigated. However, the more specific an influencing factor becomes, the larger the database would need to be to provide a sufficient sample size of debarking percentages per factor for robust average debarking percentages of that particular factor. The limitation of this solution might be the presence of multiple influencing factors present on a single log. Therefore, logs can only be categorized in sample groups if one outstanding influencing factor is present.

Second: recording an additional image from the blind-side of the log. By collecting two opposing images of a single log, the recorded surface can be substantially increased. Thereby, inaccuracies within the calculation of the debarking percentages can be lowered and single debarking percentages might become comparable to targeted influencing factors. However, a certain area still has to be estimated and potential overlapping of the two images might have a negative influence on the precision of the debarking percentage evaluation.



Third: recording up to 100% of the log surface. Within the research project, an attempt to record a higher share of the actual surface has already been tested. The recording method was changed from a photo-optical based recording system towards a terrestrial LiDAR based system. Hereby, multiple scans can be merged, and a higher share of the log surface can be recorded without moving the log. By placing optical markers on the log, and turning the log, a complete measurement of the log surface can also be achieved. The laser-based recording system would also solve the above-mentioned issues of log curvature and perspective of 2D measurements. The 3D projection of the log enables the possibility of unrolling the stem surface from a cylindrical into a flat projection. In turn, this would provide a future improvement potential of Stemsurf, where the currently applied projection is replaced by a triangulation based on the LiDAR data.

As applying the polygons to the different surface geometries in Stemsurf requires three quarters of the processing time, this could also become a major area of improvement. To shorten the processing time per image, an automated recognition function, based on the shape and color (RGB) information gathered in the study seems feasible. This could help to expand the limitation of processed data per test run in the future and make the measurement system more productive, especially when combined with LiDAR recording. However, according to findings from Weidenhiller and Denzler [26], automated pattern recognition on the base of RGB color data might be impacted by certain limitations. Within the described study, the algorithm based on color never exceeded an accuracy of 60% since a high share of surface areas was labelled as “unknown” due to occurring color similarities within bark and wood patterns. Weidenhiller and Denzler [26] also stated that an algorithm which is based solely on color values of single pixels will always perform unsatisfactorily, due to atypical bark colors or impurities such as dirt present on a log [26].

To clarify the influences of log characteristics (sweeps, taper, forks) on the accuracy of the photo-optical system, it is recommended to perform additional laboratory tests presenting different log diameters and lengths with defined and known reference debarking percentages and compare those to the results obtained in Stemsurf. A checkerboard test presenting defined square areas could further help understanding the distortion effects within Stemsurf. Furthermore, by presenting identical images with known surface polygon shares to a group of test users, the user-related error could also be determined.

## 5. Conclusions

The focus of this study was to design a computer software “Stemsurf” to quantify the debarking percentage of processed logs and evaluate its performance under laboratory and field conditions. In the laboratory, results revealed that the standard deviation of the single debarking percentages varied greatly, which was mostly caused by only measuring 50% of the log surface through a single image and estimating the remaining surface proportionally. However, when grouping single debarking percentages together through calculation of average debarking percentages, Stemsurf provided precise and robust results. Throughout all tested sample sizes ( $n = 12$  to  $n = 96$ ) the standard deviation remained within the anticipated 5% range. Distortion, perspective, and user-related errors resulted in a positive bias of 6.7%.

In general, the designed measurement system proved to be a promising tool to evaluate field-based debarking percentages as it was capable of recording and processing large amounts of data within an acceptable period while producing robust and reliable results of debarking percentages. Potential areas of improvement are an automatic detection of the polygons to reduce the image processing time and the image recording system to cover a higher share of the log surface to make the single debarking percentages more accurate and comparable to single influencing factors of the debarking percentage.

**Author Contributions:** Conceptualization, all authors; methodology, all authors; software, T.S. and S.S.; writing-original draft preparation, J.B.H. and E.R.L.; writing-review and editing, all authors; supervision, E.R.L.; funding acquisition, S.W.

**Funding:** This research was funded by the German Federal Ministry of Food and Agriculture (FKZ 22013213, 22012214).

**Acknowledgments:** We would like to thank Grünberger, Rosnau, Mayer, and Vater for their support and assistance within the field data gathering and Peters for the assistance throughout the laboratory tests. For their support on Stemsurf measurements, we would like to thank Rosnau, Mayer, Müller, and Huber. We also acknowledge the Bavarian and Lower Saxonian State forests for providing forest stands and the entrepreneurs Harrer & Mayer and Raker for their contribution. Finally, we thank our project partner the Kuratorium für Waldarbeit und Forsttechnik e.V. for their support and great cooperation.

**Conflicts of Interest:** The authors declare no conflict of interest.

## References

1. Simard, M.; Pinto, N.; Fisher, J.B.; Baccini, A. Mapping forest canopy height globally with spaceborne lidar. *J. Geophys. Res.* **2011**, *116*, G04021. [\[CrossRef\]](#)
2. Lim, K.; Treitz, P.; Wulder, M.; St-Onge, B.; Flood, M. LiDAR remote sensing of forest structure. *Prog. Phys. Geogr.* **2003**, *27*, 88–106. [\[CrossRef\]](#)
3. Müller, J.; Brandl, R.; Buchner, J.; Pretzsch, H.; Seifert, S.; Strätz, C.; Veith, M.; Fenton, B. From ground to above canopy—Bat activity in mature forests is driven by vegetation density and height. *For. Ecol. Manag.* **2013**, *306*, 179–184.
4. Bayer, D.; Seifert, S.; Pretzsch, H. Structural crown properties of Norway spruce (*Picea abies* [L.] Karst.) and European beech (*Fagus sylvatica* [L.]) in mixed versus pure stands revealed by terrestrial laser scanning. *Trees* **2013**, *27*, 1035–1047. [\[CrossRef\]](#)
5. Boudreau, J.; Nelson, R.F.; Margolis, H.A.; Beaudoin, A.; Guindon, L.; Kimes, D.S. Regional aboveground forest biomass using airborne and spaceborne LiDAR in Québec. *Remote Sens. Environ.* **2008**, *112*, 3876–3890. [\[CrossRef\]](#)
6. Kunneke, A.; van Aardt, J.; Roberts, W.; Seifert, T. Localisation of Biomass Potentials. In *Bioenergy from Wood: Sustainable Production in the Tropics*; Seifert, T., Ed.; Springer: Dordrecht, the Netherlands, 2014; pp. 11–41.
7. Hilker, T.; van Leeuwen, M.; Coops, N.C.; Wulder, M.A.; Newnham, G.J.; Jupp, D.L.B.; Culvenor, D.S. Comparing canopy metrics derived from terrestrial and airborne laser scanning in a Douglas-fir dominated forest stand. *Trees* **2010**, *24*, 819–832. [\[CrossRef\]](#)
8. Moorthy, I.; Miller, J.R.; Hu, B.; Chen, J.; Li, Q. Retrieving crown leaf area index from an individual tree using ground based lidar data. *Can. J. For. Res.* **2008**, *34*, 320–332.
9. Strahler, A.H.; Jupp, D.L.B.; Woodcock, C.E.; Schaaf, C.B. Retrieval of forest structural parameters using a ground based lidar instrument. *Can. J. For. Res.* **2008**, *34*, 426–440. [\[CrossRef\]](#)
10. Bao, Y.; Ni, W.; Wang, D.; Yue, C.; He, H.; Verbeeck, H. Effects of tree trunks on estimation of clumping index and LAI from HemiView and Terrestrial LiDAR. *Forests* **2018**, *9*, 144. [\[CrossRef\]](#)
11. Hopkinson, C.; Chasmer, L.; Young-Pow, C.; Treitz, P. Assessing forest metrics with a ground-based scanning lidar. *Can. J. For. Res.* **2004**, *34*, 573–583. [\[CrossRef\]](#)
12. Henning, J.; Radtke, P. Detailed stem measurements of standing trees from ground-based scanning Lidar. *For. Sci.* **2006**, *52*, 67–80.
13. Watt, P.J.; Donoghue, D.N.M. Measuring forest structure with terrestrial laser scanning. *Int. J. Remote Sens.* **2005**, *26*, 1437–1446. [\[CrossRef\]](#)
14. Maas, H.G.; Bienert, A.; Scheller, S.; Keane, E. Automatic forest inventory parameter determination from terrestrial laser scanner data. *Int. J. Remote Sens.* **2008**, *29*, 1579–1593. [\[CrossRef\]](#)
15. Yu, X.; Liang, X.; Hyypä, J.; Kankare, V.; Vastaranta, M.; Holopainen, M. Stem biomass estimation based on stem reconstruction from terrestrial laser scanning point clouds. *Remote Sens. Lett.* **2013**, *4*, 344–353. [\[CrossRef\]](#)
16. Spriggs, R.; Coomes, D.; Jones, T.; Caspersen, J.; Vanderwel, M. (2017): An Alternative Approach to Using LiDAR Remote Sensing Data to Predict Stem Diameter Distributions across a Temperate Forest Landscape. *Remote Sens.* **2017**, *9*, 944. [\[CrossRef\]](#)
17. Fang, R.; Strimbu, B.M. Stem Measurements and Taper Modeling Using Photogrammetric Point Clouds. *Remote Sens.* **2017**, *9*, 716. [\[CrossRef\]](#)
18. Yan, Y.; Xia, M.; Fan, S.; Zhan, M.; Guan, F. Detecting the competition between Moso bamboos and broad-leaved trees in mixed forests using a terrestrial laser scanner. *Forests* **2018**, *9*, 520. [\[CrossRef\]](#)

19. Labelle, E.R.; Heppelmann, J.B.; Borchert, H. Application of Terrestrial Laser Scanner to Evaluate the Influence of Root Collar Geometry on Stump Height after Mechanized Forest Operations. *Forests* **2018**, *9*, 709. [[CrossRef](#)]
20. Schad, K.C.; Schmoldt, D.L.; Ross, R.J. *Nondestructive Methods for Detecting Defects in Softwood Logs*; USDA Forest Service Research Paper FPL-RP-546; USDA: Washington, DC, USA, 1996; 13p.
21. Fonseca, M.A. *The Measurement of Roundwood: Methodologies and Conversion Ratios*; CABI Publishing: Wallingford, Oxfordshire, UK, 2005; 269p.
22. Colin, F.; Laborie, M.P.; Fortin, M. Wood properties: Future needs, measurement and modelling. *Ann. For. Sci.* **2015**, *72*, 665–670. [[CrossRef](#)]
23. Hodges, D.G.; Anderson, W.C.; McMillin, C.W. The economic potential of CT scanners for hardwood sawmills. *For. Prod. J.* **1990**, *40*, 65–69.
24. Rais, A.; Ursella, E.; Vicario, E.; Giudiceandrea, F. The use of the first industrial X-ray CT scanner increases the lumber recovery value: Case study on visually strength-graded Douglas-fir timber. *Ann. For. Sci.* **2017**, *74*, 9.
25. Gjerdrum, P. Sawlog scaling accuracy before and after barking, and the importance for sawn timber recovery – A case study. *Wood Mater. Sci. Eng.* **2012**, *7*, 120–125. [[CrossRef](#)]
26. Weidenhiller, A.; Denzler, J.K. On the suitability of colour and texture analysis for detecting the presence of bark on a log. *Comput. Electr. Agric.* **2014**, *106*, 42–48. [[CrossRef](#)]
27. Roth, A.; Kennel, E.; Knoke, T.; Matthes, U. Line intercept sampling: An efficient method for sampling of coarse woody debris? *Eur. J. For. Res.* **2003**, *122*, 318–336.
28. Murphy, G.E.; Pilkerton, S.J. Seasonal Impacts of Bark Loss on Simulated Payloads, Bark Delivery, and Transport Costs for Freshly Harvested Logs. *For. Prod. J.* **2011**, *61*, 71–76. [[CrossRef](#)]
29. Weisstein, E.W. Point-Line Distance–2-Dimensional. Available online: <http://mathworld.wolfram.com/Point-LineDistance2-Dimensional.html> (accessed on 29 April 2019).
30. Baumgartner, R.; Brüchert, F.; Staudenmaier, J.; Sauter, U.-H. Bark measurements with x-ray technology. In Proceedings of the COST E 53 Conference – Quality Control for Wood and Wood Products, Warsaw, Poland, 15–17 October 2007.
31. Thomas, L.; Shaffer, C.A.; Mili, L.; Thomas, E. Automated detection of severe surface defects on barked hardwood logs. *For. Prod. J.* **2007**, *57*, 50–56.



© 2019 by the authors. Licensee MDPI, Basel, Switzerland. This article is an open access article distributed under the terms and conditions of the Creative Commons Attribution (CC BY) license (<http://creativecommons.org/licenses/by/4.0/>).

## Appendix III

In-stand debarking with the use of modified harvesting heads:  
a potential solution for key challenges in European forestry

Heppelmann et al. 2019b



## In-stand debarking with the use of modified harvesting heads: a potential solution for key challenges in European forestry

Joachim B. Heppelmann<sup>1,2</sup> · Eric R. Labelle<sup>2</sup> · Stefan Wittkopf<sup>1</sup> · Ute Seeling<sup>3</sup>

Received: 22 January 2019 / Revised: 7 August 2019 / Accepted: 28 August 2019  
© The Author(s) 2019

### Abstract

Modern forestry is increasingly confronted with challenges that appear with intensive forest management and the progression of the effects of climate change. The forestry sector is able to react to the changing conditions by adapting management plans, forest structure or planting tree species with a higher stress resistance. However, during stand management activities, silvicultural treatments and harvesting operations can have an impact on the further development of the remaining forest ecosystem. In Germany, the most widely used harvesting system for thinning operations is a single-grip harvester used for felling and processing trees followed by a forwarder for timber extraction from the machine operating trails to roadside. In this research project, debarking rollers and other modifications designed for Eucalyptus harvesting heads were tested on conventional harvesting heads for the first time to assess the possibility of adding debarking to mechanized forest operations under Central European conditions. Seven field tests with varying tree species, diameters and age classes, were established within German state forests in Lower Saxony and in Bavaria. These tests were repeated in both summer and winter seasons to evaluate the influence of associated tree sap flows on debarking quality. Three different harvesting heads were modified to assess the altered mechanical characteristics and setups. To assess debarking ability originating from head modifications, a photo-optical measurement system developed within the scope of the project was used. The results demonstrate that especially for summertime operations, simple modifications to currently used harvesting heads are able to provide an average debarking efficiency up to 90% depending on the modifications. Another key finding is that a negatively affected sap flow, experienced during wintertime operations, resulted in 46% lower debarking efficiency, while spruce bark beetle infestations only resulted in a wider spread of the variation. Additionally, the vertical position of the log within the tree proved to have an influence on debarking efficiency, resulting in 15% lower average debarking for butt logs and 9% for top logs as compared to middle logs. Since a debarking process requires the stem to be fed through the harvesting head on multiple occasions to remove bark, average harvesting productivity might be reduced by approx. 10% compared to productivity measured with conventional harvesting heads. Considering the results and the extent of the modifications, the system proved to be a potential addition to existing harvesting methods facing changing challenges in future forestry.

**Keywords** Debarking · Single-grip harvester · Forest operations · Norway spruce · Scots pine · Bark beetle · Sustainability · Nutrients · European forestry

---

Communicated by Martin Moog.

✉ Joachim B. Heppelmann  
Joachim.heppelmann@hswt.de

✉ Eric R. Labelle  
eric.labelle@tum.de

<sup>1</sup> University of Applied Science Weihenstephan-Triesdorf,  
Hans-Carl-von-Carlowitz-Platz 3, 85354 Freising, Germany

<sup>2</sup> Department of Ecology and Ecosystem  
Management, Technical University of Munich,  
Hans-Carl-von-Carlowitz-Platz 2, 85354 Freising, Germany

<sup>3</sup> Kuratorium für Waldarbeit und Forsttechnik e.V.,  
Spremlinger Straße 1, 64823 Groß-Umstadt, Germany

Published online: 05 September 2019

Springer

## Introduction

In times of climate change and uprising biotic (insects, fungi, pathogens) and abiotic (fire, drought, storms, snow, nutrient/soil exploitation) threats to the European forests (Holuša et al. 2017; Irauschek et al. 2017; Seidl et al. 2017) and the intensified utilization of forest resources (Weis and Göttlein 2012), modern forestry needs to be flexible and proactive in finding new solutions. A promising approach to address several of the above-listed challenges might be the return to a once broadly established practice—in-stand debarking.

Debarking of logs remains an essential work task within the value chain of timber processing industries. All sectors of the wood industry share the same commonality as the wood needs to be debarked before it can be processed into further products (Baroth 2005; Gerasimov and Karjalainen 2006). This particular stem-debarking process went through a major development from manual debarking within the stands to fully mechanized debarking facilities located directly at wood processing industries. Furthermore, distribution channels for the remaining bark were established to create additional value instead of raising costs for waste disposal (Kupferschmid 2001). Despite the technical achievements of debarking logs at the processing facilities, debarking harvested wood directly in the forest stand offers multiple benefits as well, if the bark remains within the forest ecosystem.

The main benefits of in-stand debarking are:

- In context with an intensified utilization of forest biomass, nutrients located in the bark are remaining within the ecosystem and become available to the residual forest stand (Hopmans et al. 1993; Weis and Göttlein 2012; Nieminen et al. 2016; Yan et al. 2017)
- Log mass and volume are reduced through the removal of the bark, and the subsequent exposure of the wood surface entails a higher drying rate as compared to barked logs (Heppelmann et al. 2019a). These changes in mass and volume result in a lower wood humidity and therefore again less mass that needs to be transported. Depending on the species, a threefold increase in drying rate was measured when comparing 0% debarked and 100% debarked wood (Defo and Brunette 2005; Röser et al. 2011)
- In-stand debarking can play a major role when considering forest health and spruce bark beetle (*Ips typographus*) prevention. This is especially the case for wind-throw operations, as the layer between the bark and wooden body is the breeding habitat, which can be removed or destroyed by debarking the logs (Schroeder and Lindelow 2002; Thorn et al. 2016; Irauschek et al.

2017). The urgency for new spruce bark beetle preventative treatments is highlighted by the fact that within the Bavarian state forests, over 710,000 m<sup>3</sup> had to be harvested in 2017 as a result of spruce bark beetle infestations. This affected volume accounted for 15% of the total annual harvest (BaySF 2018)

- Burning debarked wood produces less ash remains and fine dust emissions compared to barked wood, reducing problems within the thermal utilization of wood. (Werkelin et al. 2005)

Occurring negative effects of in-stand debarking can be summarized as:

- Increased complexity of material handling due to the rather slippery wood surface of stems immediately after harvesting and debarking
- Removal of the protective bark layer, thus exposing the surface of stems to contaminants such as soil or fungi
- The utilization of bark as a source of secondary products (e.g., chemical products (Kofujita et al. 1999), gardening products, fuel for drying chambers, fuel for heating and power plants (Päivinen et al. 2012) is limited.

To reintroduce debarking as part of the harvesting process, a method of combining debarking with modern and highly mechanized operations was sought. Similarities with the harvesting systems in Eucalyptus plantations all over the world (Brazil, South Africa, Australia, New Zealand, etc.) showed a potential solution. In Eucalyptus plantations, most of the harvesting is performed with single-grip debarking harvesting heads that are mounted on excavator-based or wheeled-based harvesters. As the harvested wood is destined to be distributed into the pulp and paper industry, the bark needs to be completely removed. Since the bark of Eucalyptus trees sticks tightly onto the wooden body as the felled trunks begin to dry out, debarking during the processing phase is the preferred method.

Since over 60% of the German wood harvest is performed with fully mechanized systems and the most common harvesting system focuses on single-grip harvesters and forwarders, the question was raised if harvester-based debarking might also be practicable for central European forests based on the model of Eucalyptus plantations (BaySF 2018). Therefore, a research project was initiated to investigate the potential and general feasibility of this system. To maintain operational flexibility and lower costs, the project focused on modifying conventional harvesting heads (with modification costs limited to 10,000 €) to provide them with debarking ability instead of utilizing purpose-built Eucalyptus harvesting heads (costs up to 90,000 €). Within this approach, it was essential to establish a benchmark of the achievable debarking results with the most reasonable effort.

Within the scope of the project, the following research questions were under review:

- (1) Determine which type of technical modifications and operational procedures are required to adapt conventional harvesting heads and provide them with debarking ability.
- (2) Perform field tests to evaluate and quantify the debarking percentage achieved with different modification setups being operated on spruce and pine trees during both summer and winter seasons.
- (3) Obtain a general overview of harvesting productivity between conventional and modified harvesting heads.

## Materials and methods

### Machinery, harvesting heads and modifications

The focus of the project was directed at modifying conventional harvesting heads on harvesters currently used by German forest entrepreneurs. Prior to modifications and field tests, a market study was performed to identify suitable harvesting heads. Apart from the technical compatibility of assuring a match between the harvesting head and the harvester and the use of the appropriate on-board computer operating software (Timbermatic, MaxiXplorer, Opti4G, Dasa, etc.), three of the largest manufacturers of cut-to-length wood harvesting technology on the German market were selected (Table 1). The combination of harvesting head and harvester will be referred to as Setup 1 (S1), Setup 2 (S2) and Setup 3 (S3).

The three harvesting heads tested were technically modified in order to achieve a debarking effect within the harvesting process. Modifications were performed with the

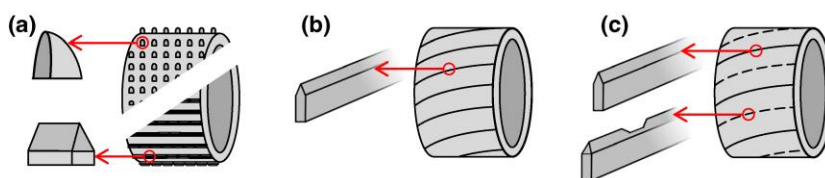
support of machine manufacturers and were limited to the use of existing parts. In this regard, attempts were made to minimize the complexity of modifications in order to limit the conversion costs and were therefore mostly focused on the replacement of feed rollers.

The replacement of conventional feed rollers (Fig. 1a) with debarking rollers (Eucalyptus rollers) forces the felled tree to rotate along its longitudinal axis within the harvesting head during the processing phase, thus allowing the delimiting knives and the feed rollers themselves to remove bark on the entire stem surface. In addition, the blade-like edges on the feed rollers ensure a cutting of the bark layer into sections and a slight lift from the wooden body, thus enabling the delimiting knives to slip below the bark layer. Most common debarking rollers can be divided into two traction-type sub-categories: single-edge and diamond-shape. The S1 and S2 harvesting heads were modified with single-edge rollers (Fig. 1b), while S3 used the hybrid diamond-shape system (Fig. 1c). Hereby, a normal series of full-length splines are alternating with a series of splines with edges, which can increase traction in the forward and backward thrust, but lowers the rotational frequency of the logs (Fig. 1c).

To prevent damage of the measuring wheel through the occurring lateral force and to improve the measurement accuracy, measuring wheels were also replaced on the S1 and S3 prototypes with wider and less aggressive wheels. The S3 prototype was further modified with the addition of improved top and upper delimiting knives. All modifications are illustrated in Fig. 2. Besides these technical modifications, harvesting head software settings referring to feed pressure, knife pressure, feed speed, pressure curves, pitch angle of the delimiting knives and length measurement calibration had to be addressed. Those settings depended on tree species and dimensions as well as

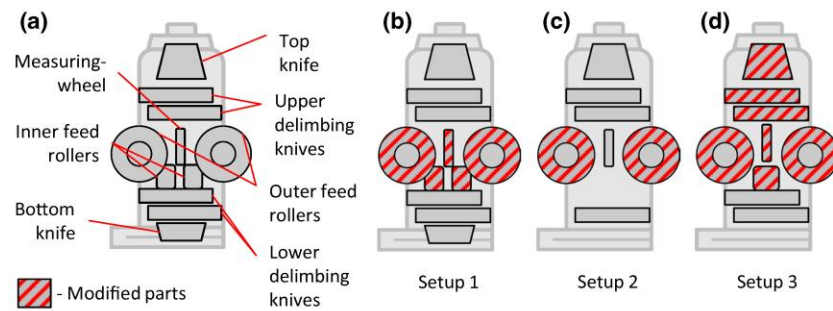
**Table 1** Harvesters and harvesting heads studied

	Setup 1	Setup 2	Setup 3
Harvester	John Deere 1270E	TimberPro 620E	Ponsse ScorpionKing
Harvesting head	John Deere H480C	Log Max 7000C	Ponsse H7



**Fig. 1** Different traction types of feed rollers with **a** conventional spike rollers without debarking effects or abilities, **b** single-edge debarking roller, used within the S1 and S2 tests, **c** diamond-edge debarking rollers, used within the S3 tests

**Fig. 2** Modifications performed on the three different harvesting head prototypes with **a** general overview of modifiable parts of conventional harvesting heads, **b** tested S1 modifications (inner and outer feed rollers, measuring wheel), **c** tested S2 modifications (feed rollers), **d** tested S3 modifications (inner and outer feed rollers, measuring wheel, upper delimiting knives, top knife)



machine type and were therefore adjusted individually for each machine and at every harvest site.

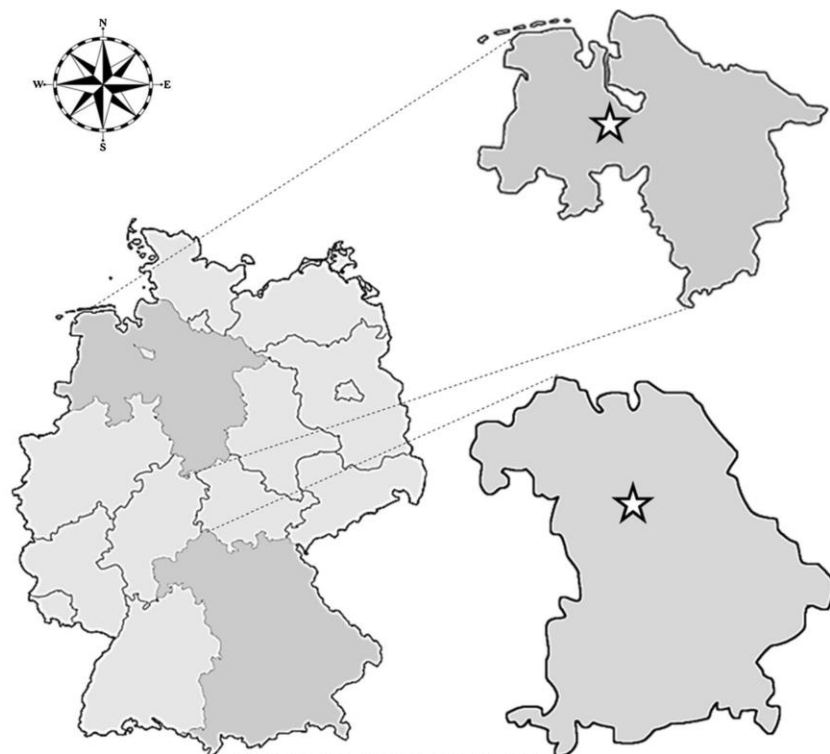
Following hardware and software modifications, the actual process of wood harvesting needed to be altered with an additional step: after the tree was felled, it was fed in its complete length forward and back (steps 1 and 2) through the harvesting head. At the same time, the trunk was spinning on its own longitudinal axis and the bark and branches were being removed during the first pass and only bark during the second pass. Crosscutting the delimiting stem into assortments (step 3) occurred at the end of the harvesting process during a third pass. Within

the field trials, operators were instructed to consistently apply the above-mentioned process (steps 1–3), in order to obtain comparable results for all harvesting operations within the seven field trials.

### Study design and stand characteristics

Seven field tests were established in Lower Saxony and Bavaria within Germany (Fig. 3). Tests were repeated in both summer and winter seasons to evaluate the influence of associated tree sap flows on debarking quality. In total, 1720 debarked Norway spruce and Scots pine logs (976

**Fig. 3** Test sites located within Germany: Harpstedt 52°57'32.3"N, 8°38'46.7"E, northern Germany (Lower Saxony); Kipfenberg 48°52'43.1"N, 11°17'08.7"E, southern Germany (Bavaria)





logs in summer operations and 744 in winter operations) originating from about 400 trees were investigated. Summer and winter seasons were defined according to the German Meteorological Service (DWD)—winter: from December 01 to February 28/29; summer: from June 01 to August 31.

The test sites provided different stand characteristics and conditions (Table 2). For the first test runs, optimal tests sites and conditions (species, stem diameter and tree form) for the investigated harvesting heads were chosen to determine whether modifications performed on commonly used harvesting heads could provide debarking ability. Due to its strong apical dominance and associated straight growth structure in combination with its high importance for the German forestry sector (annual softwood harvest accounts for 76% of the total harvested wood in Germany in 2017 (Statistisches Bundesamt 2018), the focus was set on the Norway spruce (*Picea abies* L. H. Karst) and Scots Pine (*Pinus sylvestris* L.).

Due to the harvesting guideline of the Bavarian State Forests in summer 2017 (only harvesting of bark beetle-infested

wood), the S2 and S3 summer field tests had to be performed in spruce bark beetle-infested stands. Therefore, pine was not present within those particular field trials.

The S3 winter is listed as a winter test, but due to delays of machine and stand availability, the test run was carried out at the end of April and the sap flow was partly established. Therefore, S3 winter needed to be considered as an intermediate/spring test and was thereby excluded from further investigations relating debarking percentages to season.

### Field sampling and equipment

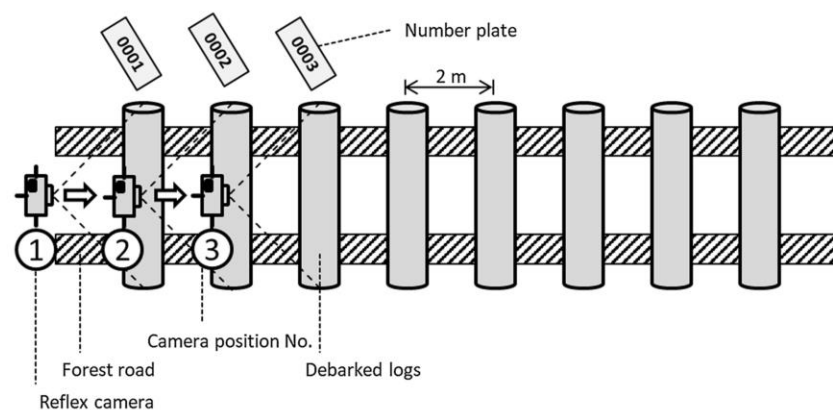
After the trees were harvested and processed with the respective head configurations, each single log was registered and tagged with a number plate that was inserted into the wood at the end surface of the log. Individual logs could therefore be linked to a specific tree and position (e.g., butt log, mid log, top log). Overall, an average of 245 logs per field test (originating from 55 trees) were assessed. After processing and tagging, logs were forwarded to a nearby forest road or landing area with a forwarder where they were unloaded and randomly

**Table 2** Basic stand characteristics presented by operation

Operation	Location	Tree species composition	DBH	Age
Setup 1 summer I	Lower Saxony	Mixed coniferous stand—mainly Scots pine mixed with Norway spruce and silver birch ( <i>Betula pendula</i> Roth)	15–20 cm	35
Setup 1 winter	Lower Saxony	Mixed coniferous stand—mainly Scots pine mixed with Norway spruce	15–25 cm	50
Setup 1 summer II	Lower Saxony	Pure coniferous stand of Scots pine	25–30 cm	70
Setup 2 winter	Bavaria	Mixed coniferous stand—mainly Norway spruce mixed with Scots pine and larch ( <i>Larix decidua</i> Mill.)	30–35 cm	65 (50–105)
Setup 3 winter <sup>a</sup>	Bavaria	Mixed coniferous stand—mainly Norway spruce mixed with Scots pine and larch	30–35 cm	65 (50–105)
Setup 2 summer <sup>b</sup>	Bavaria	Pure coniferous stand of Norway spruce	25–40 cm	30–100
Setup 3 summer <sup>b</sup>	Bavaria	Pure coniferous stand of Norway spruce	25–40 cm	30–100

<sup>a</sup>Intermediary test performed in April, <sup>b</sup>Norway spruce bark beetle treatments

**Fig. 4** Schematic showing the positioning of logs placed on a forest road ready for picture acquisition



**Table 3** Infestation index with associated average surface moisture content (wet basis)

Index value	Value 1	Value 2	Value 3	Value 4	Value 5	Value 6	Value 7	Value 8
Average surface moisture content	100%	99–90%	89–80%	79–70%	69–60%	59–50%	49–40%	39–30%

placed in a parallel fashion perpendicular to the forest road with an approximate spacing of 2 m between logs (Fig. 4). At the forest road, the diameter at both ends (mm accuracy) and the length of each log (cm accuracy) were recorded with a caliper and measuring tape. Logs varied between 2.4 and 5.4 m in length, and diameters ranged from 8.0 to 54.7 cm. Following these measurements, a single picture per log (broadside) was taken with a reflex camera mounted on a tripod set at a height of 1.50 m above ground (Heppelmann et al. 2019b). The camera was moved after every picture and relocated to the next log.

Bark beetles and associated pathogens often have a direct influence on the sap flow of the infested tree (Kirisits and Offenthaler 2002; Wullschlegel et al. 2004). To evaluate the intensity of spruce bark beetle infestations in the S2 and S3 summer field tests, the sap flow was examined by measuring the moisture content of the log surface directly after the debarking process with a contact moisture meter, using the invasive-electrical resistance method to determine the proportional water content (wet basis). Therefore, the surface moisture content was measured on three logs per tree originating from different heights (butt log, mid log, top log). Those three measurements were taken to calculate an infestation index ranging from 1 to 8, where an unaffected sap flow equaled 1 (control group with 100% moisture content) and a completely interrupted sap flow (almost dead tree) equaled 8 with an average surface moisture content of 39–30% (fiber saturation point) (Table 3).

To obtain a general overview of the technical performance, harvester data from the on-board computer (OBC) were gathered and analyzed. Due to time and logistics constraints and because of the secondary importance of productivity in this particular article, harvesting productivity for the debarking configuration was performed by an associated project partner and focused on the S1 summer test where most trees harvested were Scots pine (avg. dbh of 15–20 cm, age of 35). As a benchmark, harvesting productivity of the same machine, operator and harvesting head under conventional settings was obtained from a stand of very similar dimensions and species composition. In addition to OBC reports, two video cameras were mounted inside the harvester cabin and on the boom and were both aimed at the harvesting head to acquire video footage of the entire operation of the S1 summer test. The footage could be viewed in the office whenever questions arose concerning specific trees. The required time for debarking was calculated by subtracting the average processing time with debarking minus the average processing time without debarking (Eq. 1):

$$T_{\text{deb}} = T_{\text{Operation+Debarking}} - T_{\text{Operation}} \quad (1)$$

## Debarking percentage

Once in the office, debarking percentage was evaluated with a computer software solution that was developed within the scope of the project (Stemsurf). With the digital pictures of logs as input, the software used polygons to define debarked areas and calculated the total debarking percentage for the log using the additional measured physical values (diameter and length) (Heppelmann et al. 2019b). The polygons were delineated manually and defined either as wood, bark, inner bark, covered, or not measurable. The inner bark was multiplied by a factor of 0.5 as it indicated partial debarking. Due to distortion, pixels located toward both extremities and the upper and lower sides of the stem were also subjected to a factor as the pixel described more surface than a pixel located in the middle of the log. Therefore, the curvature and distortion were also taken into account by considering this effect within the Stemsurf algorithm (Heppelmann et al. 2019b). The debarking percentage was calculated as (Eq. 2):

$$\text{Percent debarking} = 100\% - (X\%_{\text{Bark}} + (Y\%_{\text{Inner-bark}} \times 0.5)) \quad (2)$$

## Statistical analyses

IBM SPSS Statistics version 24 (SPSS) was used to perform the statistical tests and evaluations. Kolmogorov–Smirnov (KS) tests were performed to verify the data for normal distribution, besides the optical evaluation via Q–Q plots and histograms. KS tests showed that for most of the datasets, a normal distribution was not present. Particularly for the summer tests, this is due to the limitation at a 100% debarking percentage. Therefore, Levene’s test was carried out to test the homogeneity of variances and to check for the possibility of using *T* test to investigate the significant differences. As those tests appeared to be negative as well, it was decided that for all evaluations, parametric tests (ANOVA with Tamhane and Dunnett T3 post hoc) were performed. Both the Tamhane and Dunnett T3 post hoc tests were chosen as they are particularly tailored for datasets without the homogeneity of variances. The decision to perform parametric tests was based on the information from latest publications that parametric tests can deliver robust results even when the assumption of normal distribution is violated (Norman 2010) as long as the database is large enough to calculate with the asymptotic significance. According to Norman (2010), a sample size of 5 up to 10 per group is sufficient to calculate robust results even for non-normal and asymmetric distributions. The present sample sizes

for statistical calculations exceeded this requirement often to a high extent, depending on the calculation. The sample size is therefore presented throughout the investigated results. However, to crosscheck the results on significant differences between the investigated data groups, additional nonparametric Kruskal–Wallis tests followed by a pairwise comparison were performed to ensure that the parametric test results were robust and plausible.

## Results

### Effect of machine type and season on debarking efficiency

An overview of the full dataset, subdivided sequentially according to the field tests, showed many significant differences between single field tests (Fig. 5). The most prevalent difference in debarking percentage appeared between the summer and winter tests resulting in a statistically lower average debarking efficiency (46%) in wintertime as compared to summer operations. In this overall result, S3 winter test was not included in the winter data because it was considered an intermediary trial.

Based on a one-way ANOVA followed by Tamhane and Dunnett T3 post hoc tests, significant differences between the single machine setups during the summer season were detected. When considering summer operations, the highest

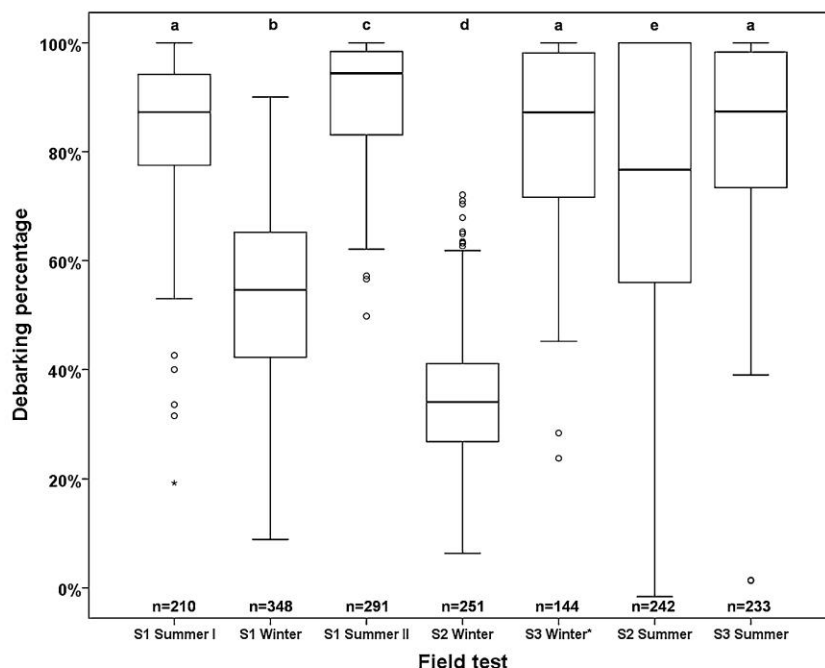
debarking percentage (90%) was achieved within the S1 summer II test, whereas the lowest debarking percentage (73%) and the highest amount of variation were experienced during the S2 summer tests. Both further summer tests, S1 summer I and S3 summer, performed similarly with an average debarking percentage of 84%.

Significant differences were also present within the winter tests. Average debarking percentage varied between 35% for S2 winter and 54% for S1 winter, thus equaling a 56% increase in debarking efficiency in favor for S1 winter. With an average debarking percentage of 83%, the intermediary test S3 winter performed on par with the S1 summer II and S3 summer tests.

### Effect of species and season on debarking efficiency

To determine whether tree species influenced debarking efficiency, debarking results within the S1 tests were investigated separately (Fig. 6). The S1 field tests were chosen, as sufficient trees of both species were harvested under comparable conditions during summer and winter seasons. A one-way ANOVA showed no statistical difference between the debarking efficiency of spruce and pine for summer operations. With 87%, the achieved average debarking percentage was similar for both species. Conversely, a significant difference was detected between the average debarking percentages of pine and spruce during winter operations. Average debarking percentage varied between 43% for spruce and

**Fig. 5** Overview of all measured debarking percentages within the different field tests (pine and spruce species combined). S1—Setup 1; S2—Setup 2; S3—Setup 3. S3 Winter\* represents the Setup 3 intermediate/spring test (April)



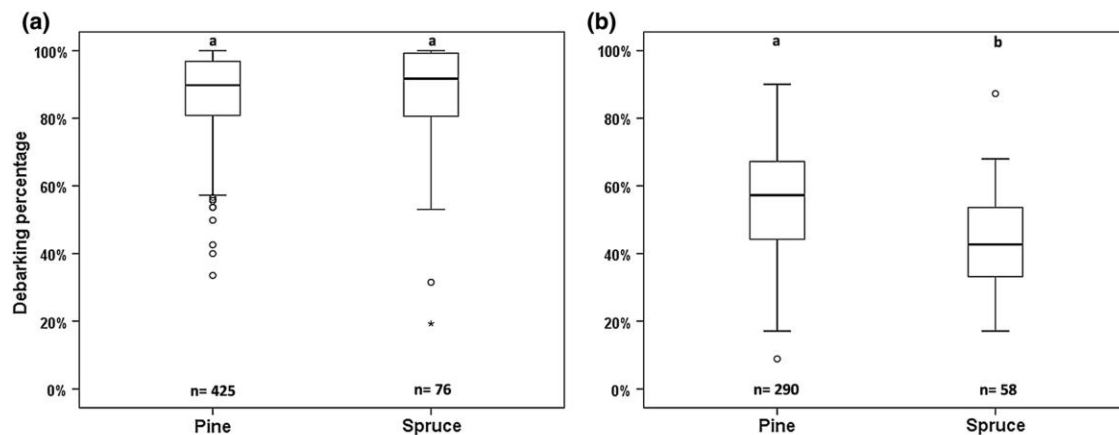


Fig. 6 Measured debarking percentages for spruce and pine subdivided in **a** summer and **b** winter test for the S1 debarking database

55% for pine, thus equaling a 24% higher average debarking efficiency favoring pine in winter operations.

#### Effect of log diameter, species and season on debarking efficiency

To examine whether log diameter had an influence on debarking efficiency, diameter categories were established in 5 cm increments and the associated debarking percentages clustered. A one-way ANOVA showed significant differences between the mean debarking percentages for pine in summer (Fig. 7a). The average debarking percentages illustrate an inverse parabola with the maximum debarking efficiency of 91% occurring at diameter 20–25 cm and significantly lower debarking results of 79% observed at 10–15 cm. The average debarking percentage tended to be lower when large stem diameters were encountered, particularly during summer operations (Fig. 7a, b).

Debarking spruce during summer operations resulted in the highest debarking percentage (82%) occurring for 30–35 cm log diameter, but also lower debarking percentages for both small and large diameters with 70% for 10–15 cm and 78% for 40–45 cm (Fig. 7b). The differences within the debarking percentages were not statistically significant.

For winter operations, pine showed a comparable trend with lower average debarking percentages to both extremities of the diameter range and the maximum for medium diameters (Fig. 7c). At both extremes, lower average debarking percentages were measured at 39% for 5–10 cm and 56% for 20–25 cm compared to the maximum of 57% for log diameters of 15–20 cm. However, according to a one-way ANOVA, only

the difference between the smallest diameters compared to the rest of the dataset can be considered as significant.

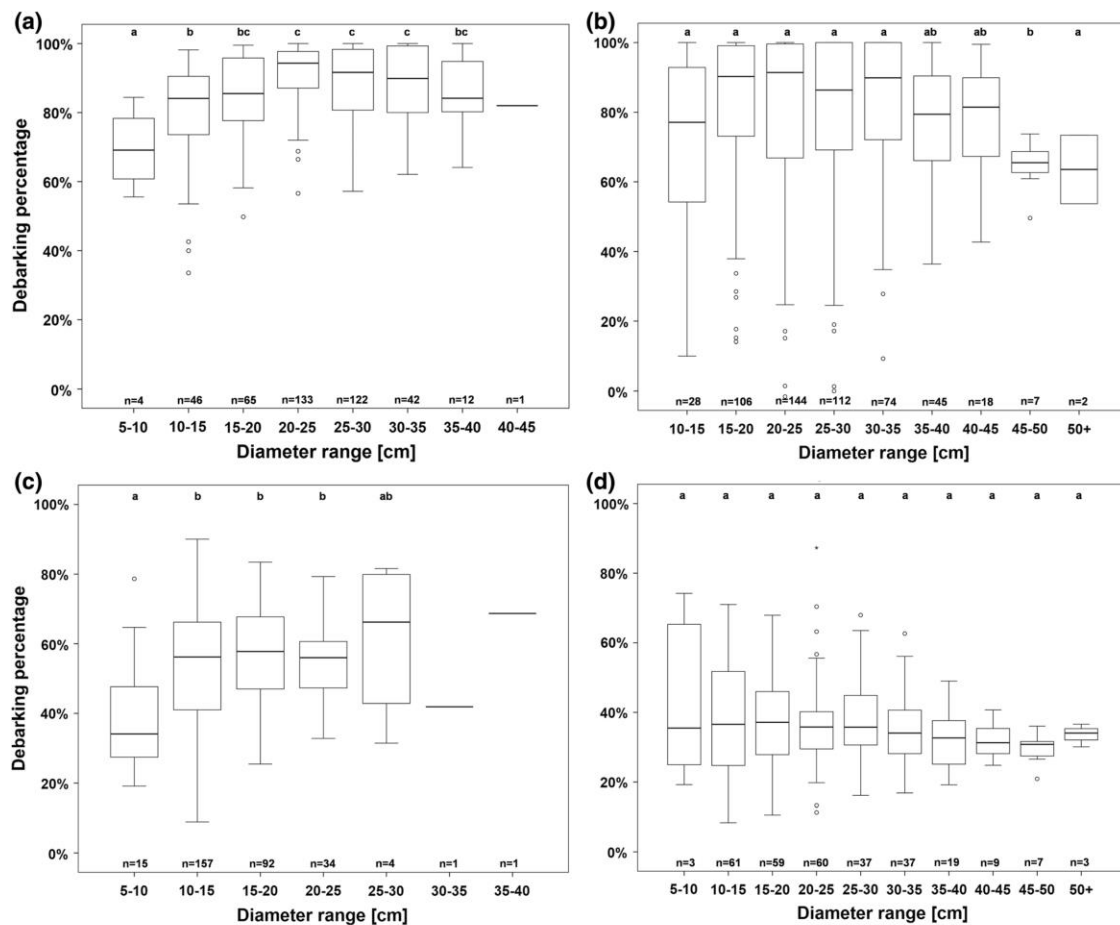
Within winter spruce operation, log diameter had no significant influence on the debarking efficiency (Fig. 7d). The average debarking percentages ranged between 38 and 32%. Nevertheless, it was noticeable that for summer operations and pine winter operations, the debarking percentages tended to decrease for smaller and larger diameters resulting in a considerably lower average debarking percentage for those diameter classes compared to the measured maximum.

#### Effect of log positioning in tree, species and season on debarking efficiency

Visual observations during the field tests hinted that for butt logs and top logs the debarking efficiency tended to be lower. To investigate this assumption, logs were clustered according to their vertical position in the tree (Fig. 8) where B refers to a butt log,  $M_x$  to a middle log and t to a top log. A one-way ANOVA followed by post hoc tests revealed significant differences between the average debarking percentages of butt logs (62%) compared to the middle logs (73%) of the same trees, thus resulting in a 15% lower average debarking percentage for butt logs (Fig. 8a–d). This effect was stronger in summer than in winter operations and more prevalent for pine than for spruce. Similar to the butt logs, the top logs also showed lower average debarking efficiency (66%) when compared to middle logs, resulting in a 9% lower average debarking percentage.

#### Influence of spruce bark beetle infestation on debarking efficiency

Statistical calculations showed no clear trend toward lower debarking percentages for spruce with rising sap flow for

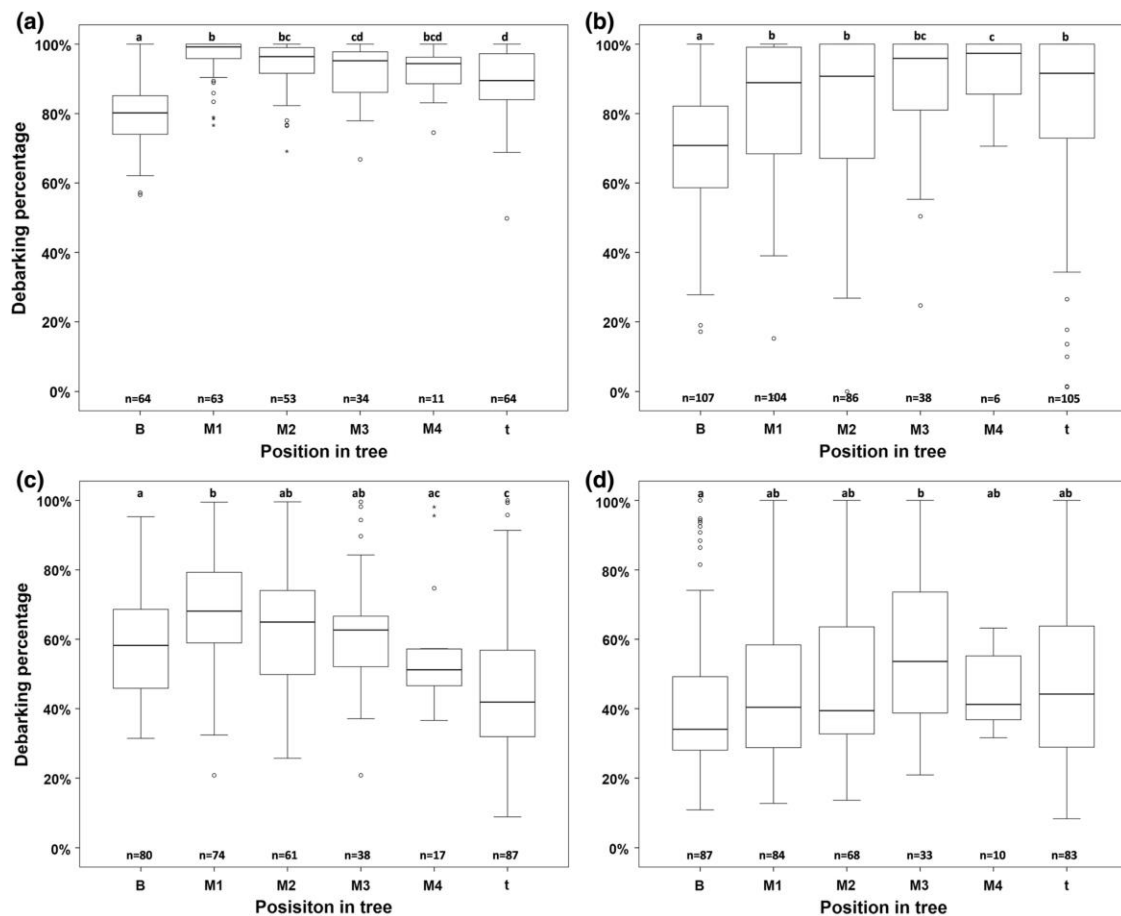


**Fig. 7** Overview of the measured debarking percentages by 5-cm log diameter categories and species/season according to: **a** pine summer, **b** spruce summer, **c** pine winter and **d** spruce winter tests

both investigated setups (S2 and S3) linked to bark beetle infestations (Fig. 9). Debarking results improved as infection level increased, reaching the maximum debarking efficiency at category 6 showing a higher average debarking percentage compared to the control group (category 1). The trend seemed similar for both tested setups, with one exception: the variance of measured debarking percentages was similar for both control groups. However, the spread of variance was higher for the S2 prototype resulting in a lower overall debarking percentage (Fig. 9a). The lowest average debarking percentage was detected for trees of category 8 as also the variance of debarking percentages increased for both tested setups.

### Harvesting productivity

To estimate harvesting productivity loss and the associated additional costs, OBC data were collected for (1) harvester and conventional harvesting head; (2) harvester with modified harvesting head applying debarking as part of the hardware and harvesting process. Average harvesting productivity was calculated for pine trees in summertime over a quantity of 227 m<sup>3</sup> with the conventional head and with 461 m<sup>3</sup> for the debarking configuration. Comparing the main work cycle elements, processing time was higher for harvesting operations with debarking, while a higher share of other activities (manipulation, operational delays, non-operational



**Fig. 8** Overview of the measured debarking percentages by vertical position of the log within the tree (B—butt log; M1–M4—mid-positioned logs, t—top log) and species/season according to: **a** pine summer, **b** spruce summer, **c** pine winter and **d** spruce winter tests

delays) was recorded during conventional harvesting operations (Fig. 10).

Considering the absolute values, average processing time (delimiting, cutting stem into assortments) was increased by 48% compared to conventional (single pass-over) operations (Table 4). Under the tested conditions, harvesting productivity was on average 10% lower with the debarking configuration compared to conventional operations performed in similar sized stems (Abschlussbericht 2018).

## Discussion

### Study design and modifications

The study design was chosen to determine whether conventional harvesting heads could be modified to allow

debarking within the harvesting process. In general, the modifications performed well, especially during summer operations. With three passes of the stem within the harvesting head, debarking percentages over 90% were regularly achieved. In a second step, the demands and debarking expectations of the wood processing industry on the debarked roundwood needs to be clarified. If those requirements for the different treatments (e.g., spruce bark beetle), operations (summer, intermediate or winter time) or assortments are known, further tests might be necessary to optimize certain modifications in order to meet the given demands. A strategic approach could be developments specifically tailored for European tree characteristics (larger diameter often exhibiting complex crown structure), as most of the tested modification parts were originally designed to debark Eucalyptus trees. By installing additional top and/or bottom delimiting knives,

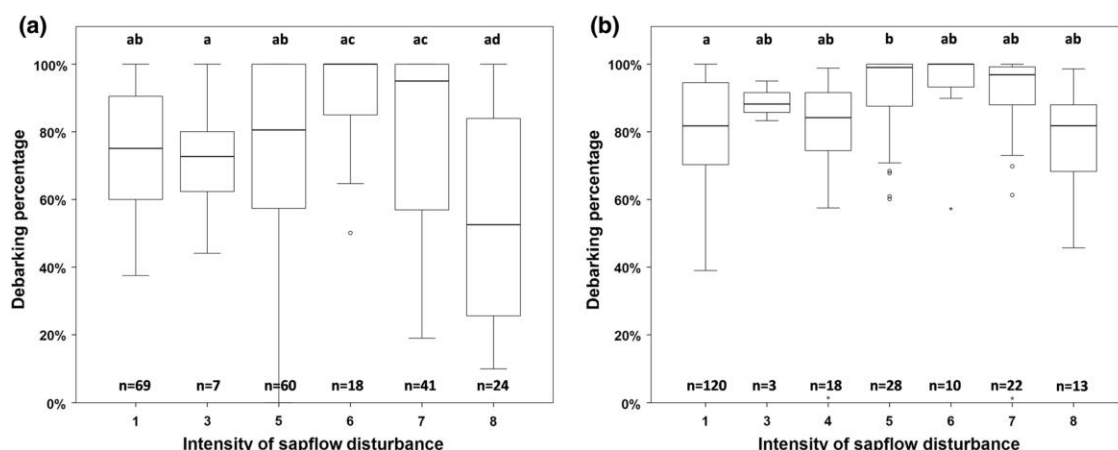


Fig. 9 Overview of the measured debarking percentages of spruce categorized by intensity of sap flow disturbance (1—no disturbance, 8—very high disturbance) for: **a** Setup 2 summer test and **b** S3 summer test carried out in bark beetle-infested stands

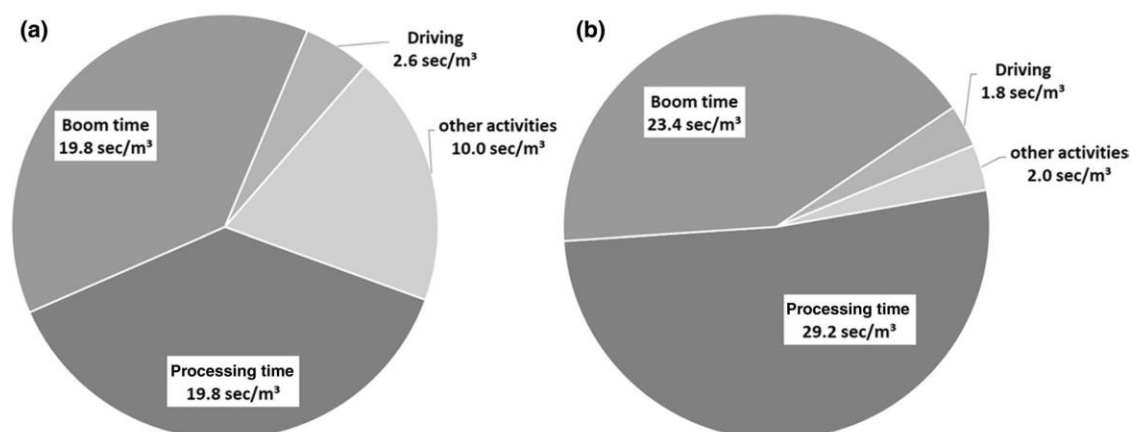


Fig. 10 Total share of the main working elements for harvesting operations **a** conventional without debarking, **b** with debarking

**Table 4** Productivity data of on-board harvesting computer of conventional and debarking operations

	Average log volume (m <sup>3</sup> u.b. <sup>1</sup> )	Average processing time/stem (s)	Average boom and driving time/stem (s)	Productivity (m <sup>3</sup> /h)
Conventional	0.18	20.0	22.7	12.3
Debarking	0.18	29.5	26.6	11.1

<sup>1</sup>Under bark

increased debarking efficiency could potentially be obtained. Besides the delimiting knives, the presence of a top saw on the harvesting head could improve overall

processing performance by limiting the frequency of re-gripping of the trunk. Such top saws are already available but were not standard on any of the tested harvesting heads within the scope of the project.

Beyond hardware modifications, it would also be possible to increase the number of passes to achieve a higher debarking percentage. However, as reported by van der Merwe et al. (2015), more severe damages on the log surface and loss of biomass can occur. When the number of passes is limited to three (as in our study), Labelle et al. (2019) reported that the frequency and severity of penetrations into the wood caused by the feed rollers were actually deeper under standard configuration (8.7 mm) than with the debarking configuration (6.7 mm).

The fact that two of the summer tests had to be performed within spruce bark beetle stands added important information about the performance of the setups within this field of application, but basic information on the performance of S2 and S3 modifications under undisturbed summer conditions is lacking.

### Field sampling and equipment

To assess the debarking result and debarking percentage, two possible approaches were under consideration: (1) measuring within the sawmill and (2) measuring within the forest stand. In modern sawmills, measurement devices are usually installed that are not only capable of measuring the physical characteristics of a log but also measure the debarking percentage. The difficulty with the first approach is that it required transportation of all logs from the felling site to a processing facility, a working step that could have triggered complications in retracing individual logs in addition to further increasing the debarking percentage because of wood handling during transport. Instead, it was decided to design a measurement system that easily delivers a sufficient amount of data and could be performed with a manageable effort directly in the forest. The measurement system was based on a photo-optical evaluation system that used one picture of every stem and estimated the rest of the stem surface. Tests showed that the average debarking percentage is very precise over a larger sample size ( $n > 20$ ) (Heppelmann et al. 2019b). However, the downside was that the individual values have only limited significance, since in the photo-optical analysis only a maximum of 50% of the total surface was displayed and actually measured. A second approach using a T-LiDAR was also pilot-tested for a subset of logs within the project. This measurement system showed promise to provide a higher area of log surface to be measured and also obtain detailed information on the taper and curviness of the logs. Further studies should consider T-LiDAR as the main instrument to collect log information.

### Effect of machine type, season and beetle infestation on debarking efficiency

The most remarkable difference in the debarking efficiency was detected between the winter and summer field tests. We believe this was linked to the sap flow of the tree, which worked as a natural separation layer between the bark and the wooden body (Kupferschmid 2001). When sap flow was fully established, it facilitated stripping of the bark in up to 16-meter-long strips at once. Within the winter season and therefore without this separating layer, the average debarking percentage decreased to 35–54%, while only very short segments of bark were stripped from the wooden body. With these findings, it was expected that operations within spruce

bark beetle infected stands would show similar results as the infection also impairs sap flow. However, the effect was not as strong as expected, but especially for the S2 prototype, an unusual large variation of measured debarking percentages was detected. On the other hand, the S3 prototype did not present this effect at all, delivering results comparable to the S1 summer trials. We anticipate this result is related to two main reasons. First, the tested S2 harvesting head was mounted on a harvester with limited setting options (only manual, no computer-based adjustment possible) and the delimiting knives were quit worn. This could have increased the effect of the beetle-related sap flow disturbance as brand new manufactured S3 prototype performed similar to the S1 prototypes. This hypothesis is strengthened with the latest experiences of entrepreneurs using modern S2 heads with fresh pairs of delimiting knives for debarking, reporting similar results as for the S3 harvesting head outside the project. Second, the S3 harvesting head performed a considerable share of the debarking process with the purposefully designed delimiting knives. In the S3 setup, the feed rollers actually played a minor role in the debarking process, and the rotation of the tree on its longitudinal axis served mostly as a cleaning mechanism to remove bark stripes wedged between the stem and the measuring wheel. Compared to the worn conventional delimiting knives and the fact that S2 uses mainly the feed rollers to debark the trees, this also might explain the much higher variation of measured debarking percentages in Fig. 9. Overall, this leads to the assumption that debarking percentages, especially in operations with impeded sap flow (beetle-infested stand, droughts, intermediate season, wintertime, etc.), could be further improved by modifications and optimizations of the delimiting knives.

### Effect of log diameter and its vertical position on debarking efficiency

The diameter of the processed logs was also expected to influence debarking efficiency. This effect could partly be proven for pine, but not for spruce (see Fig. 7). For pine, the average debarking percentage was decreasing as the processed diameters were decreasing. However, the sample sizes that are carrying this assumption must be considered as they were getting rather limited at both ends of the investigated range, describing a trend rather than a robust calculation. This effect could have originated from a different circumstance investigated in Fig. 8. Within the field tests, it was observed that for the butt logs, a segment of un-debarked area remained for every tree. This occurred because neither the feed rollers nor the delimiting knives can process this part of the log since they are located further away from the cutting plane. Potential software solutions for this problem already exist within the harvester operating



systems, originally developed for Eucalyptus operations, but were not utilized for the field tests within the studies. Those settings might help to mitigate this effect in the future.

Another observed impact factor was the rather complex crown architecture (forks, crooks, severe curviness), especially for Scots pine stands in Lower Saxony. The poorly shaped upper parts of the trees, combined with their high branchiness and smaller stem diameters, resulted in a lack of forward thrust and grip of the harvesting head, which negatively impacted the debarking efficiency. Taken together, lower debarking percentages for both larger and smaller stem diameters could be influenced by the diameter itself or originate from the combination of diameter and vertical position within a tree (butt log and top/crown logs).

### Nutrients

According to Weis and Göttlein (2012), 14% of the nitrogen, 17% of the phosphorus and 31% of the calcium found in Norway spruce trees are located in the bark under average conditions in Bavaria (Germany). This represents a considerable share of the total bound nutrient content that is stored in a rather small volume compared to the wooden body. With 36% of the calcium located in the solid wood, the share is almost equal to bark. Therefore, the debarking system has the potential to keep those nutrients within the forest ecosystem. At this stage, the debarking efficiency is 46% higher for summer than for winter operations. Considering the nutrient supply, the debarking percentage should therefore be improved for winter operations, as for example an average of 35–56% of the bark and its associated nutrients were left in the forest for the S1 and S2 winter trials. This could also help to treat the deposition of organic acids originating from softwood litter directly within the stand without the need of costly fertilizer or lime application (Reif et al. 2014). A broad distribution of the bark is expected to turn out beneficial as the contained nutrients are not accumulated on a rather small area. In the study, the operator was instructed to work as usual, also with debarking, to achieve a better comparability between the two modifications. Therefore, the bark was mostly accumulated in small piles in a close range beside the machine operating trail and in rather few cases also with the brush material on the operating trail. As supported by Borchert et al. (2015), nutrient concentration within machine operating trails can be redistributed beyond the trail and therefore be accessible to residual trees.

### Harvesting productivity

The productivity calculations provided in this study should only be used as general orientation since the amount of information gathered is only able to provide a coarse overview. Furthermore, productivity data were collected in a

rather poor quality stand of Scots pine without any previous silvicultural treatment. Factors such as increased wear, additional fuel consumption and entrepreneurial profits were not considered as the database was not sufficient to provide robust information, yet. Furthermore, actual productivity impacts for the different stages of modification are not known as those modification kits are not readily available on the market. The prices for conversions will also vary if further optimization and developments will be carried out for European markets. These factors will clarify as large amounts of wood will be harvested and processed with this system over a longer period. At the present stage, only a conservative estimation of a 10% lower productivity when using modified debarking heads as compared to conventional heads can be given as orientation (not considering the above-mentioned factors). The conservative estimation is supported by a study by Magagnotti et al. (2011) that assessed the costs of stump-site debarking in Eucalyptus plantations and reported potential monetary savings of 11–17% when avoiding stump-site debarking. When calculating the additional costs based on the collected data and further considering a higher fuel consumption during the debarking process, the 10% productivity reduction results in a comparable cost range to the one presented in the study by Magagnotti et al. (2011). However, it is necessary to reiterate that these assumptions are not based on a representative amount of data. Further impacting factors on harvesting productivity could be: stand characteristics, tree species, tree architecture, terrain and slope, operator experience, stand density and regrowth, size of harvest blocks, and fast and flexible availability of modified machines.

### Conclusions

The debarking of common European tree species (Norway spruce and Scots pine) through modifications of conventionally used harvesting heads proved to be possible, financially feasible and promising for future operations. Within the summer season, the prototypes of John Deere H480C (S1), Log Max 7000C (S2) and Ponsse H7 (S3) achieved average debarking percentages of 73%, up to 90%, respectively, when keeping the number of passes through the harvesting head constant at three.

Throughout the seven field tests, the season and associated tree sap flow proved to be the main influencing factors on the debarking efficiency. This led to a 46% lower average debarking percentage for winter operations as compared to summer operations. Therefore, the tested systems are currently recommended for summer operations if spruce bark beetle stands need to be treated or the general export of nutrients lowered within the harvesting operations. For comparable performances in winter operations, further

modifications would be required, or the working procedure would need to be customized.

Harvesting productivity for the S1 summer test was on average 10% lower with the debarking modifications as compared to harvesting with the conventional head operating in similar sized trees. This decreased productivity was mostly attributed to the increased number of pass-overs of the stem in the head required to achieve the debarking effect.

Overall, the tested debarking systems proved to be a very promising solution for upcoming modern forestry challenges within European forest ecosystems. Additional research focusing on a more comprehensive analysis of harvesting productivity and associated harvesting costs should be performed to gain a more holistic understanding of the proposed systems.

**Acknowledgements** The project was funded by the German Federal Ministry of Food and Agriculture through the Fachagentur für Nachwachsende Rohstoffe e.V. FKZ 22013213, 22012214. Fees for open access were generously provided by the Technical University of Munich. We want to thank Jochen Grünberger and the Kuratorium für Waldarbeit und Forsttechnik e.V. for providing harvesting productivity data. Furthermore, we want to thank Bernd Heinrich, Eberhard Guba, Wendelin Weis and Dr. Johannes Windisch for their support and help toward a successful research project. We also want to acknowledge the Bavarian and Lower Saxonian State forests for providing forest stands and the entrepreneurs Harrer&Mayer and Raker for their contribution. For providing information on the development of debarking systems in Bavaria and ash remains after thermal use, we want to thank Mr. Leidner and Mr. Windl for their contributions within the research project. Special thanks are also due to Wahlers Forsttechnik/Ponsse, John Deere and LogMax for providing parts and expertise. Finally, the lead author wants to extend gratitude to Dr. Bernd Heppelmann for mentoring the research and providing help and advice throughout the entire project.

**Open Access** This article is distributed under the terms of the Creative Commons Attribution 4.0 International License (<http://creativecommons.org/licenses/by/4.0/>), which permits unrestricted use, distribution, and reproduction in any medium, provided you give appropriate credit to the original author(s) and the source, provide a link to the Creative Commons license, and indicate if changes were made.

## References

- Abschlussbericht A (2018) Nährstoffentzüge bei Holzernte minimieren durch die Nutzung von entrindenden Harvesterfällköpfen (Debarking Head). Bundesministerium für Ernährung und Landwirtschaft, Bonn, p 100
- Baroth R (2005). Literature review of the latest development of wood debarking (Report A, 27)
- BaySF (2018) Statistikband. Bayerische Staatsforsten, Regensburg, p 30
- Borchert H, Huber C, Göttlein A, Kremer J (2015) Nutrient concentration on skid trails under brush mats—is a redistribution of nutrients possible. *Croat J For Eng* 32(2):243–252
- Defo M, Brunette G (2005) A log drying model and its application to the simulation of the impact of bark loss. *For Prod J* 56(5):71–77
- Gerashimov Y, Karjalainen T (2006) Development of wood procurement in Northwest Russia: round wood balance and unreported flows. *Eur J For Res* 125(2):189–199
- Heppelmann JB, Labelle ER, Wittkopf S (2019a) Static and sliding frictions of roundwood exposed to different levels of processing and their impact on transportation logistics. *Forests* 10:7
- Heppelmann JB, Labelle ER, Seifert T, Seifert S, Wittkopf S (2019b) Development and validation of a photo-based measurements system to calculate the debarking percentages of processed logs. *Remote Sens* 11(9):16
- Holuša J, Hlásny T, Modlinger R, Lukášová K, Kula E (2017) Felled trap trees as the traditional method for bark beetle control: Can the trapping performance be increased? *For Ecol Manag* 404:165–173
- Hopmans P, Stewart HTL, Flinn DW (1993) Impacts of harvesting on nutrients in a eucalypt ecosystem in southeastern Australia. *For Ecol Manag* 59(1–2):29–51
- Irauschek F, Rammer W, Lexer MJ (2017) Evaluating multifunctionality and adaptive capacity of mountain forest management alternatives under climate change in the Eastern Alps. *Eur J For Res* 136(5–6):1051–1069. <https://doi.org/10.1007/s10342-017-1051-6>
- Kirisits T, Offenthaler I (2002) Xylem sap flow of Norway spruce after inoculation with the blue-stain fungus *Ceratocystis polonica*. *Plant Pathol* 51:359–364
- Kofujita H, ETTYU K, Ota M (1999) Characterization of the major components in bark from five Japanese tree species for chemical utilization. *Wood Sci Technol* 33(3):223–228. <https://doi.org/10.1007/s002260050111>
- Kupferschmid A (2001) *Holzkunde II Teil 4, Rindenkunde und Rindenverwertung*. Research Collection ETH Zürich Permanent Link: <https://doi.org/10.3929/ethz-a-004536640>
- Labelle ER, Breinig L, Spinelli R (2019) Extent and severity of damages caused to spruce roundwood by harvesting heads in standard versus debarking configurations. *Eur J For Res* 138:13. <https://doi.org/10.1007/s10342-018-01161-3>
- Magagnotti N, Nati C, Pari L, Spinelli R, Visser R (2011) Assessing the cost of stump-site debarking in eucalypt plantations. *Biosyst Eng* 110(4):443–449
- Nieminen M, Laiho R, Sarkkola S, Penttilä T (2016) Whole-tree, stem-only, and stump harvesting impacts on site nutrient capital of a Norway spruce-dominated peatland forest. *Eur J For Res* 135(3):531–538. <https://doi.org/10.1007/s10342-016-0951-1>
- Norman G (2010) Likert scales, levels of measurement and the "laws" of statistics. *Adv Health Sci Educ Theory Pract* 15(5):625–632. <https://doi.org/10.1007/s10459-010-9222-y>
- Päivinen R, Lindner M, Rosén K, Lexer MJ (2012) A concept for assessing sustainability impacts of forestry-wood chains. *Eur J For Res* 131(1):7–19. <https://doi.org/10.1007/s10342-010-0446-4>
- Reif A, Schulze E-D, Ewald J, Rothe A (2014) Forest liming-soil protection versus nature conservation? *For Ecol Landsc Res Nat Conserv* 14:5–29
- Röser D, Mola-Yudego B, Sikanen L, Prinz R, Gritten D, Emer B (2011) Natural drying treatments during seasonal storage of wood for bioenergy in different European locations. *Biomass Bioenergy* 35(10):4238–4247. <https://doi.org/10.1016/j.biombioe.2011.07.011>
- Schroeder LM, Lindelow A. (2002) Attacks on living spruce trees by the bark beetle *Ips typographus* (Col. Scolytidae) following a storm-felling: a comparison between stands with and without removal of wind-felled trees. *Agric For Ent* 4(1): 47–56. <https://doi.org/10.1046/j.1461-9563.2002.00122.x>
- Seidl R, Thom D, Kautz M, Martin-Benito D, Peltoniemi M, Vacchiano G (2017) Forest disturbances under climate change. *Nat Clim Change* 7:395. <https://doi.org/10.1038/nclimate3303>
- Statistisches Bundesamt (2018) Land- und Forstwirtschaft, Fischerei. Forstwirtschaftliche Bodennutzung-Holzeinschlagsstatistik. Fachserie 3, Reihe 3.3.1, Holzeinschlag 2017

- Thorn S, Bässler C, Bußler H, Lindenmayer DB, Schmidt S, Seibold S (2016) Bark-scratching of storm-felled trees preserves biodiversity at lower economic costs compared to debarking. *For Ecol Manag* 364:10–16. <https://doi.org/10.1016/j.foreco.2015.12.044>
- van der Merwe J-P, Pulkki R, Ackerman P (2015) Fibre losses during debranching and debarking of Eucalyptus pulp logs using a single-grip harvester. *South For J For Sci* 77(4):309–313. <https://doi.org/10.2989/20702620.2015.1077416>
- Weis W, Göttlein A (2012) Nährstoffnachhaltige Biomassennutzung. *LWF aktuell* 90:44–47
- Werkelin J, Skrifvars B-J, Hupa M (2005) Ash-forming elements in four Scandinavian wood species. Part 1: summer harvest. *Biomass and Bioenergy*. 29(6):451–466
- Wullschleger SD, McLaughlin SB, Ayres MP (2004) High-resolution analysis of stem increment and sap flow for loblolly pine trees attacked by southern pine beetle. *Can J For Res* 34(11):2387–2393. <https://doi.org/10.1139/x04-118>
- Yan T, Zhu J, Yang K, Yu L, Zhang J (2017) Nutrient removal on the different harvesting scenarios for larch plantations in northeast China: implications for nutrient conservation and management. *For Ecol Manag* 400:150–158

**Publisher's Note** Springer Nature remains neutral with regard to jurisdictional claims in published maps and institutional affiliations.


## Appendix IV

Static and sliding frictions of roundwood exposed to different  
levels of processing and their impact on transportation  
logistics

Heppelmann et al. 2019c

Article

# Static and Sliding Frictions of Roundwood Exposed to Different Levels of Processing and Their Impact on Transportation Logistics

Joachim B. Heppelmann <sup>1,2,\*</sup>, Eric R. Labelle <sup>2</sup>  and Stefan Wittkopf <sup>1</sup>

<sup>1</sup> University of Applied Science Weihenstephan-Triesdorf, Hans-Carl-von-Carlowitz-Platz 3, D-85354 Freising, Germany

<sup>2</sup> Department of Ecology and Ecosystem Management, Technical University of Munich, Hans-Carl-von-Carlowitz-Platz 2, D-85354 Freising, Germany

\* Correspondence: Joachim.heppelmann@hswt.de; Tel.: +49-8161-7158-98

Received: 15 June 2019; Accepted: 8 July 2019; Published: 9 July 2019



**Abstract:** Load safety is a critical component of successful logistic operations. Different influencing factors can affect the necessity of intensive load securing methods. The most dominant factor is the friction characteristics of the intended cargo. A cargo with special requirements on load safety is debarked roundwood. Due to modern forestry challenges, larger amounts of debarked roundwood assortments are now being produced within German forest operations. To assess the influence of debarking onto the static and sliding frictions of Norway spruce, pulling tests were performed and compared to barked assortments. Results showed that a significant difference in both static and sliding frictions exists between barked and debarked assortments within the first seven days after harvesting. However, this significant difference became less prominent after the logs continued to dry out and no difference was detected after 21 days. Over the monitored period, debarked assortments presented a 40%–45% faster drying rate than barked assortments. This resulted in a calculated 11%–28% additional transportable net load (m<sup>3</sup>) of debarked roundwood assortments for long trailer systems. Hence, debarked roundwood can be treated similarly to barked roundwood if stored long enough prior to road transportation, while having the potential of increased savings within the wood logistic chain.

**Keywords:** debarking; debarked roundwood assortments; Norway spruce; load security; roundwood transport

## 1. Introduction

Over the past 25 years, the transport capacity in Germany has increased by ~90%, while the amount of accidents caused by freight traffic with fatal or severe injuries decreased simultaneously by 58% (fatal) and 45% severe injuries [1]. However, the latest official statistics state that 179 accidents with personal damage and 360 accidents with serious material damage, caused by insufficient cargo safety and loose parts, occurred on German roads in 2016. The frequency of unreported cases is suspected to be even higher [2]. Those accidents and the fact that 3.6 billion tons of cargo was transported on German roads in 2016, highlight the importance of conscientious cargo security [2]. This applies especially for cargo that is not usually transported in closed container units or trailers, which is the case for roundwood assortments.

During 2016, over 52 million m<sup>3</sup> of wood were harvested in German forests and were subsequently transported on public roads towards the intended processing facility or to loading sites for bi-modal transportation via ships or trains [3,4]. Transporting this significant volume of wood with open-type

truck and trailer combinations poses potential threats to all road users if the cargo is not safely secured. No official statistics of accidents concerning timber trucks are published for Germany, but occasional accident reports are appearing in the news. In February 2017, local media reported an incident of a timber truck that lost its complete load of roundwood assortments over a 200 m road length near Arendsee (Saxony-Anhalt) and was fleeing the scene afterwards [5]. In another accident in October 2017 near Munich (Bavaria), a timber truck lost parts of the load and damaged six cars in succession, while injuring four persons [6].

The topic of general load safety for frequently transported goods has been investigated in depth and remains a critical component in reducing injuries and accidents [7–9]. This development is propelled by the fact that legal maximum loading mass on trucks are further increasing [10]. In combination with a highly competitive surrounding, regulations and controls of overloads are therefore being adapted to address load safety [4,11].

A prominent factor to describe cargo characteristics on load safety is friction, more specifically the static and sliding frictions of objects. While friction factors between wood and other materials such as metal and stone have been investigated [12,13], limited research has been published concerning timber truck load safety, and in particular when considering cargo security when transporting debarked roundwood assortments. Furthermore, different standards concerning the best practice on load security exist throughout Europe. The highest standards for load security are found in Germany and the Nordic countries and are being effectively controlled by law systems [4]. This high safety threshold triggered some concerns and reservations towards transporting the increasing assortment “debarked roundwood” in Germany.

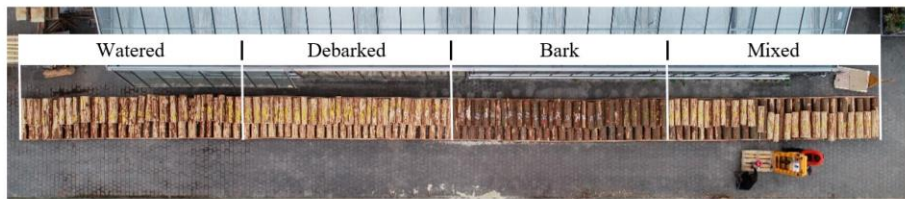
The current increase of debarked assortments is caused by the expanding threat of spruce bark beetle (*Ips typographus* L.) infestations throughout central European forests and a newly tested harvesting system that includes debarking ability as part of the harvester-based wood procurement [14–17]. Within the “Debarking Heads” research project, conventionally used harvester heads were modified to add debarking capability as part of the harvesting operations. Therefore, concerns regarding load security of debarked roundwood were communicated on multiple occasions and a comprehensive investigation was carried out to clarify differences in load security between debarked and bark roundwood assortments.

More specifically, the study aimed to quantify differences in static and sliding frictions within four treatments: (i) bark roundwood, (ii) debarked roundwood, (iii) mixed assortments, and (iv) debarked roundwood exposed to simulated consecutive heavy rainfall (watered). It was also of special interest to understand how the frictions fluctuated over time and if this had a significant influence on the differences between treatments. Particular attention was therefore given to drying rate, mass of logs, and whether the presence of water on the debarked log surface had a significant influence. Finally, suggestions on how to handle debarked roundwood compared to barked roundwood were developed to increase load safety within future transport operations.

## 2. Materials and Methods

### 2.1. Test Setup

To evaluate differences in friction characteristics, 63 freshly harvested logs (lengths of 4.1 m and 5.1 m) of Norway Spruce (*Picea abies* L. H. Karst) were cut in the Talhauser Forst located in Freising, Germany and transported to a test site less than 3 km away. At the test site, logs were unloaded on a paved surface and then cross-cut into 1.5 m sections for the support layer and into 1.0 m sections for the actual test logs. This resulted in 104 logs of 1.5 m and 100 logs of 1.0 m. Support logs were bucked into 1.5 m lengths to ensure a continuous contact with the 1.0 m test log throughout the 0.5 m pulling distance. The 100 test logs were then subdivided into the four treatments: (i) bark roundwood (bark), (ii) debarked roundwood (debarked), (iii) mixed assortments (mixture of debarked and bark sections within a single log), and (iv) debarked roundwood exposed to simulated consecutive heavy rainfall (Figure 1).



**Figure 1.** Top view of the test setup containing 100 test logs (1.0 m in length) lying on a row of support logs (1.5 m in length), divided into four treatments.

Based on the intended treatment, test logs and associated support logs were debarked with the use of hand-tools. Debarking was performed just prior to the first test run to maintain the surface moisture and sap layer as fresh as possible. Afterwards, consecutive support logs were spaced by 10 cm and fixed in position using planks and screws to ensure that no logs in the support layer would move during the pulling tests and also to avoid side friction from two adjacent test logs. During the test sessions, every test log had surface contact with only the two support logs forming the support layer. If side friction through neighboring logs was noticed prior to the pulling phase, those interfering logs were removed for the duration of the pulling cycle. In the end, a two-layered test setup was created, in which a loose test log of 1.0 m laid upon two support logs of 1.5 m length. Between the debarked and watered treatments, extra spacing was permitted to minimize the influence of the watering process on the debarked treatment. An open-eye hook was fastened on the front face of each test log to ease the attachment of the cable to the log (Figure 2).



**Figure 2.** (A) Front display of the test setup and (B) open-eye hooks used for coupling to the measuring unit.

The measuring unit consisted of a drill-powered winch (max. 2650 N pulling force), a pushing/pulling force dynamometer (max. 1000 N, 0.5 N accuracy, 6–1600 Hz sampling rate,  $\pm 0.5\%$  accuracy) and a field computer for recording and direct data storage. The winch was attached to a pallet using a 5 mm diameter steel bolt and was supported by an electric forklift (Figure 3). The moving and leveling abilities of the forklift were used to ensure the pulling and measuring unit was in proper orientation with the test log, both on the vertical and horizontal profiles, thus providing a straight vector. The mass of the forklift (840 kg including battery) further ensured that the measuring unit remained static during the pulling phase.

To simulate heavy rainfall of the watered assortment, debarked logs were watered before every trial with  $25 \text{ l/m}^2$  in accordance with the definition for heavy rain of the German Meteorological Service (DWD). This was done by using a hose, nozzle, and water supply of known volume from the nearby green house. Data recorded by a weather station located within 100 m from the test site was used to monitor weather conditions. The data was provided by the Bavarian State Institute of Forestry (LWF).

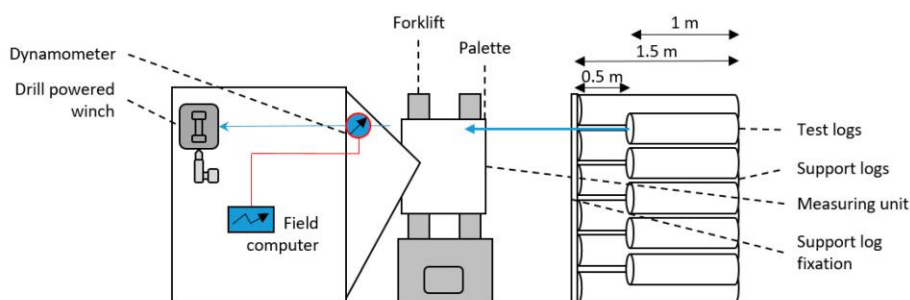


Figure 3. Schematic display of the test setup.

## 2.2. Test Measurements

Friction development was monitored in twelve tests performed over seven days with one test run occurring in the morning and the other at noontime. An additional control test was carried out after 21 days, to monitor longer-term effects on the static and sliding frictions, thus providing a total of 13 test sessions. Moreover, drying rate of logs through mass reduction was monitored as well as solar radiation intensity, air humidity and air temperature. Tests were performed at the start of the vegetation season at the end of April as it is expected that most of the debarked roundwood is supposed to be harvested and debarked within the start of the spruce bark beetle season.

The measuring methods were based on the VDI (Verein Deutscher Ingenieure) guideline VDI 2700 Part 14 of 2014, in accordance with the guideline VDI 1000 [18]. The VDI 2700 Part 14 describes a test procedure for determining the coefficients of friction (and coefficients of sliding friction in particular), which are required for the calculation of frictional forces and for the selection of load-securing measures in accordance with the series of guidelines VDI 2700 [18]. However, due to particulars of the test requirements, the measurement procedure had to be modified to ensure a high comparability between the four tested treatments (bark, debarked, mixed, and watered). Within a test session, each log was pulled horizontally three consecutive times (according to the VDI guideline) for a 10 s duration. A pulling speed of 100 cm per minute was used, thus equaling a 10-fold increase in pulling speed as compared to the speed described in the VDI guideline (10 cm per minute). This decision was made to increase the number of repetitions and provide a longer pulling length under observation. Therefore, the influence of appearing distortion factors (branch knobs and contamination by gravel and soil particles) on the sliding friction was considerably lowered. After each ten-second pull, the measurement acquisition stopped, the tension was zeroed, and a new measurement started. The chosen 50 cm pulling space (length difference between support and test logs) was sufficient to perform three consecutive pulls without repositioning the log at the starting position. The gathered static and sliding frictions of the three consecutive pulls were later averaged providing one static and one sliding friction per log and test session. To limit friction variations during the pre-load (tension building process), a threshold of 10 kg was defined in the measuring software and acted as a data acquisition starting point. Prior to every test session, the pulling force dynamometer was calibrated and zeroed.

To adequately capture the effects on the static and sliding frictions, measurements were performed at 200 Hz (50 Hz required according to VDI guideline). At this recording frequency, 2000 discrete pulling forces were detected and recorded within the 10-s pulling period. In total, 7.8 million discrete pulling forces were recorded throughout the 13 test sessions. The pulling force dynamometer recorded the forces with a resolution of 0.5 N to a maximum of 1000 N with a tolerance of 0.1%. The detected pulling forces were directly recorded by the field computer and every pulling cycle (creating 2000 discrete readings) was exported and saved as a CSV file.

The mass of each log was determined before the first test session (day 1), after the twelfth test session (day 7), and after the thirteenth test session (day 21) to correlate the required pulling forces to the mass of each log and to monitor drying effects of the different assortments. This task was done by



suspending each log individually with the forklift and using the pulling force dynamometer to record the mass to the nearest 0.05 kg. Four additional logs (two debarked and two with bark) were placed beside the test logs and used to gather solid wood discs to measure the current moisture content after every test session. To measure the moisture content of the solid wood discs, the mass was determined before and after mass stability was achieved through the drying process in the oven. The moisture content was used to calculate a dynamic drying rate between the total measurements of the log weight.

### 2.3. Data Evaluation

To minimize human related failures within the data importing, merging and calculation processes, all steps towards the final database were realized by Visual Basic macros within Microsoft Excel. After automatically uploading all CSV files into the database, the static friction was determined by taking the highest pulling force within the first two seconds of a test session, by searching the first 400 pulling force recordings. This time window was selected for every test to ensure comparable time frames for the identification of the static friction. The exact time depended on different variables and tension building processes within the pulling setup. The remaining eight seconds (1600 pulling force readings) were utilized to calculate the average sliding (Figure 4). To automatically erase the strongest outliers, a trimmed average sliding friction was calculated with the factor 0.2. This factor was chosen to erase most of the extreme events caused by branches or log shape related influencing factors. The calculated static and sliding frictions of the three consecutive pulling repetitions were then merged by calculating the average static and average sliding friction for every log per test session. IBM SPSS Statistics Version 24 (SPSS) was used to perform the statistical tests and evaluations. Kolmogorov–Smirnov (KS) tests were performed to verify the data for normal distribution. To test for significant differences parametric test (ANOVA with Tamhane/Tukey post hoc  $p = 0.05$ ) were performed.

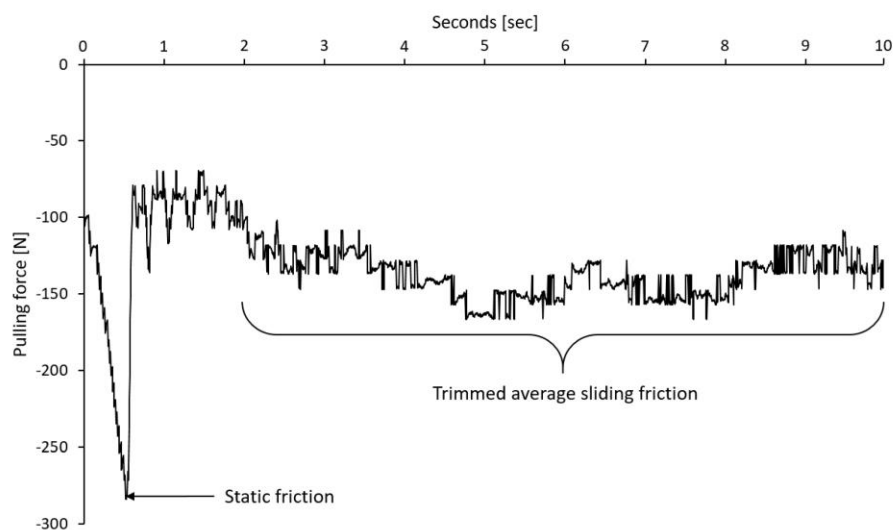


Figure 4. Example of a typical pulling force measurement curve in function of time.

### 2.4. Weather Data

Due to the size of the test setup including 100 individual test logs, the test was performed outdoors. To retrace potential significant deviations of the measured frictions linked to weather factors, such as rain, solar radiation, wind, and humidity, weather data were recorded and provided by the nearby weather station. Air temperature varied between 0 to 16.2 °C with relative air humidity ranging from 40% and 100% (Figure 5). During the recorded test week, two light rain events (night of day 4 and during day 6) were detected and amounts reported did not exceed 0.2 l/m<sup>2</sup>.

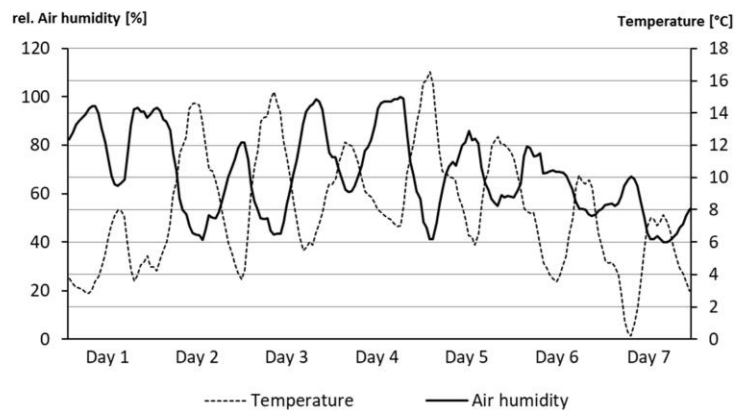


Figure 5. Display of the air temperature (°C) and relative humidity (%) during the test week (LWF).

### 3. Results

#### 3.1. Mass Loss of Test Logs after 7 and 21 Days

The investigation of the mass loss revealed considerable differences between treatments. Within the first seven days, logs of the bark treatment showed a 4% average reduction in mass compared to the initial mass. However, with an average mass loss of 2.7%, the debarked logs of the watered treatment dried noticeably slower compared to the debarked logs of the debarked treatment (7.2% mass loss within seven days) and mixed treatment (9% mass loss within seven days). This difference was less dominant after 21 days, as the logs were not watered throughout the additional two-week period. This resulted in a mass loss of 27.8% for logs within the debarked treatment, 29.3% for logs within the mixed treatment, and 23.5% for logs of the watered treatment (Figure 6). Therefore, all treatments that involved debarking showed a significantly higher drying rate as compared to the bark treatment, which had an average mass loss of 16.7% over the 21-day monitored period. Comparing drying rates between bark and debarked treatments, debarked logs dried 40 to 45% faster compared to logs with bark.

#### 3.2. Correlation between Pulling Force and Log Mass

The potential influence of log mass on both static and sliding frictions was expected to be a predominant factor within the pulling tests. Therefore, the data of the first (day 1) and control (day 21) test sessions was searched for linear correlations between log mass and associated friction measurements (Figure 7). To ease interpretation, pulling force was multiplied by  $-1$  from this point forward to convert the results into the positive display range. The investigations of the data revealed a strong linear correlation between log mass and static and sliding frictions for the bark ( $R^2 = 0.80$  and  $0.85$ ), the debarked ( $R^2 = 0.83$  and  $0.85$ ), and the mixed ( $R^2 = 0.83$  and  $0.92$ ) treatments. However, for the watered treatment, the trend appeared to be considerably weaker with  $R^2$  of  $0.50$  and  $0.42$  on day 1 and  $R^2$  of  $0.71$  and  $0.68$  on day 21. This increase within the calculated  $R^2$  towards day 21 was also observed within the other treatments, with one exception for the static friction of the mixed treatment. Further investigations of the correlation coefficient proved a strong positive correlation between the static/sliding frictions and the log mass for bark, debarked, and mixed treatments that differs between  $0.81$  and  $0.96$  (average  $0.91$ ) over all test sessions. The correlation coefficient of the watered treatment differed between  $0.68$  and  $0.87$  (average  $0.80$ ) indicating the presence of an additional influencing factor.

#### 3.3. Static and Sliding Frictions Overview

After a strong correlation was detected between the required pulling force (N) and log mass (kg) (Figure 7), pulling force was calculated per kilogram log mass, to eliminate log mass-related deviations.

When all test session results were grouped, the data showed significant differences between treatments. For both static (10.52 N) and sliding frictions (7.99 N), logs of the bark treatment showed significantly higher average frictions per kilogram log mass when compared to the other treatments including debarking (see Tables 1 and 2). The average static friction of the debarked (8.31 N), mixed (8.44 N), and watered (8.09 N) treatments performed similarly showing no significant differences between treatments (Figure 8). Surprisingly, the average sliding friction of the bark treatment (7.99 N) showed also no significant difference in the required pulling force per kilogram log mass compared to the average static frictions of treatments with debarking. Considering the overall average sliding friction, the debarked (5.60 N) and mixed (6.20 N) treatments performed on par with no significant difference (see Tables 1 and 2). The lowest overall sliding friction was measured for the watered treatment with a required pulling force of 4.32 N per kilogram wood mass, and is therefore 46% lower compared to the average sliding friction of the bark treatment and 23% lower compared to the debarked treatment.

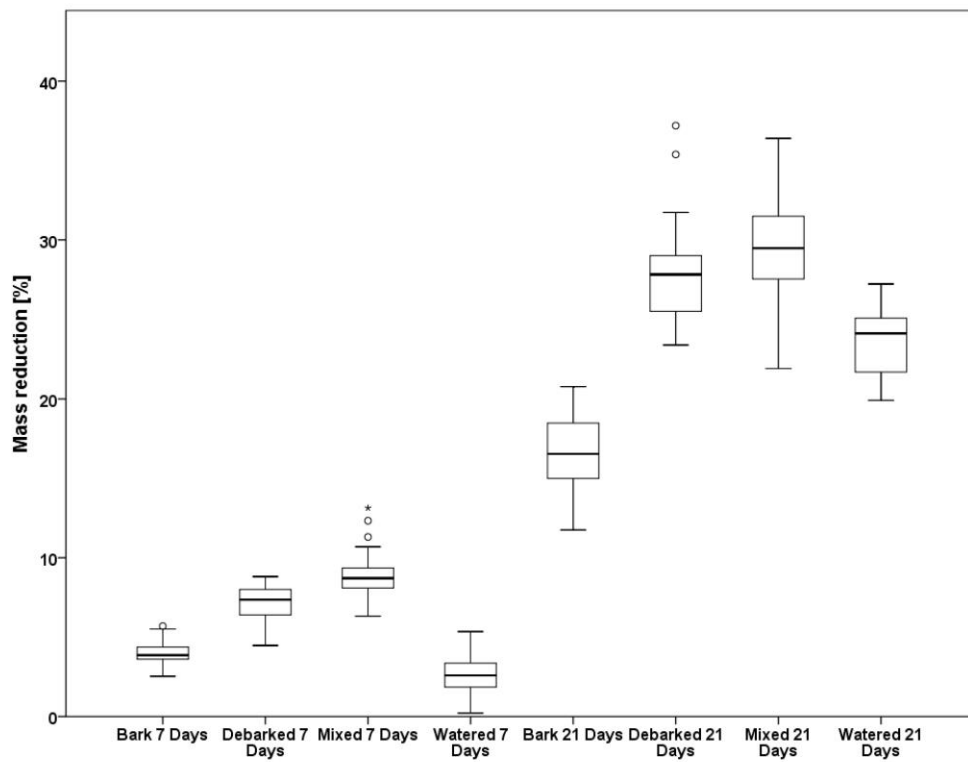
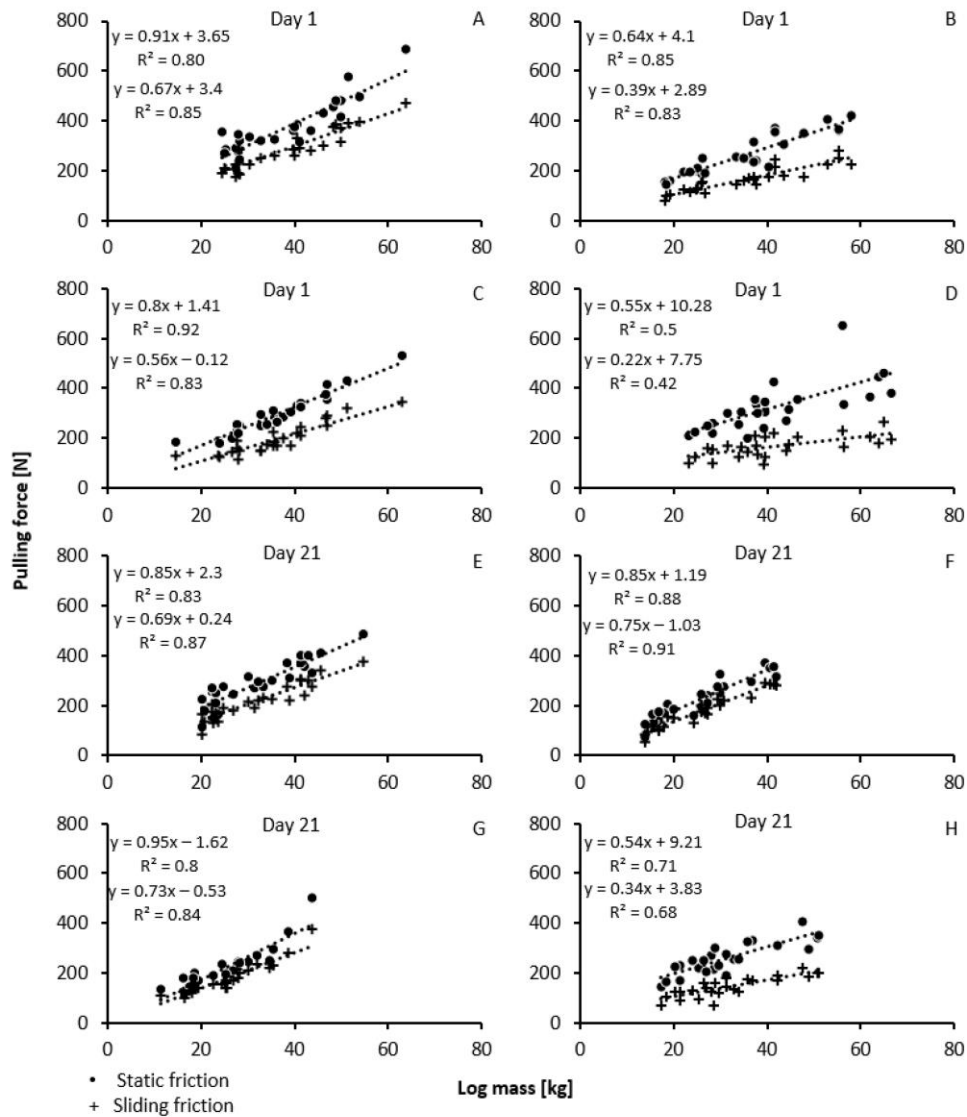


Figure 6. Mass reduction (%) of test logs within the four treatments after 7 and 21 days.

Table 1. Average static frictions in  $N_{Pull}/kg_{Log}$  of test sessions 1, 12, and 13 as well as minimum, maximum, and overall average.

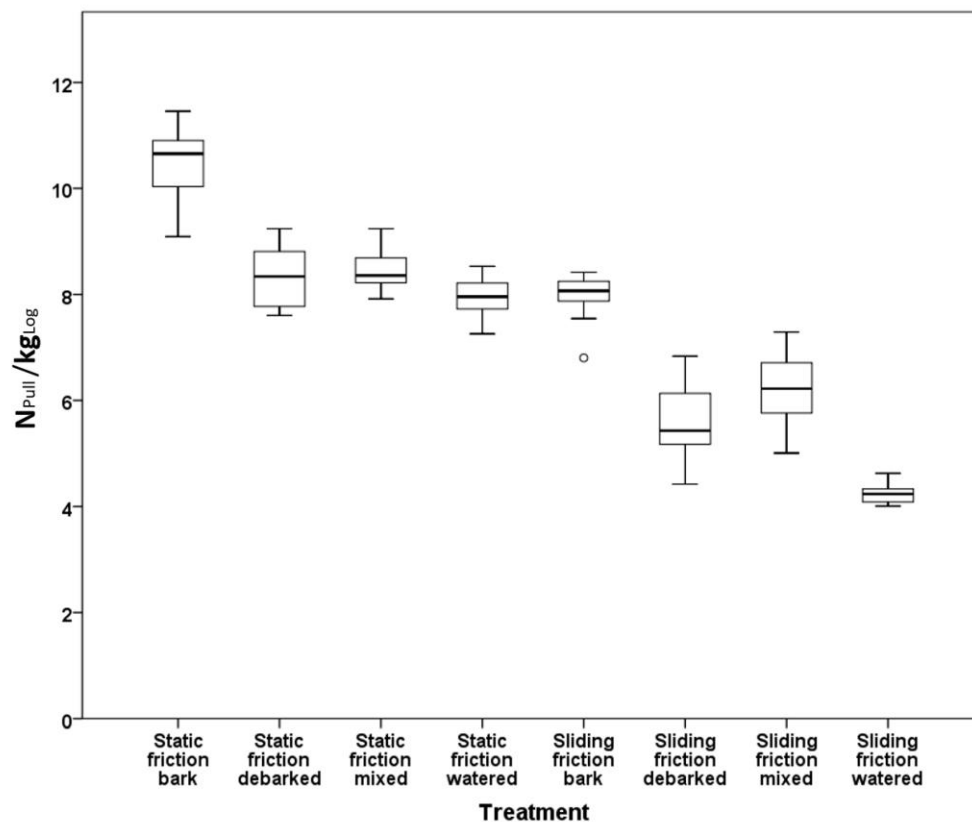
Treatment	Static friction					Overall Average
	Average Test Session 1	Average Test Session 12	Average Test Session 13	Minimum	Maximum	
Bark	9.94	9.94	9.20	9.20	11.45	10.52
Debarked	7.61	9.24	8.92	7.61	9.24	8.31
Mixed	8.31	9.24	8.76	8.44	9.24	8.44
Watered	7.83	8.62	8.41	7.44	8.62	8.09



**Figure 7.** Correlation between pulling force (N) and mass of log (kg) for the first test session (day 1) for: (A) bark treatment, (B) debarked treatment, (C) mixed treatment, and (D) watered treatment. Correlation between pulling force and mass of log for the last test session (day 21) for (E) bark treatment, (F) debarked treatment, (G) mixed treatment, and (H) watered treatment.

**Table 2.** Average sliding frictions in  $N_{Pull}/kg_{Log}$  of test sessions 1, 12, and 13 as well as minimum, maximum, and overall average.

Treatment	Sliding friction					
	Average Test Session 1	Average Test Session 2	Average Test Session 13	Minimum	Maximum	Overall Average
Bark	7.54	7.93	6.89	6.89	8.42	7.99
Debarked	4.77	6.63	6.92	4.42	6.92	5.60
Mixed	5.51	7.29	7.03	5.01	7.29	6.20
Watered	4.16	4.59	4.63	4.08	4.63	4.32



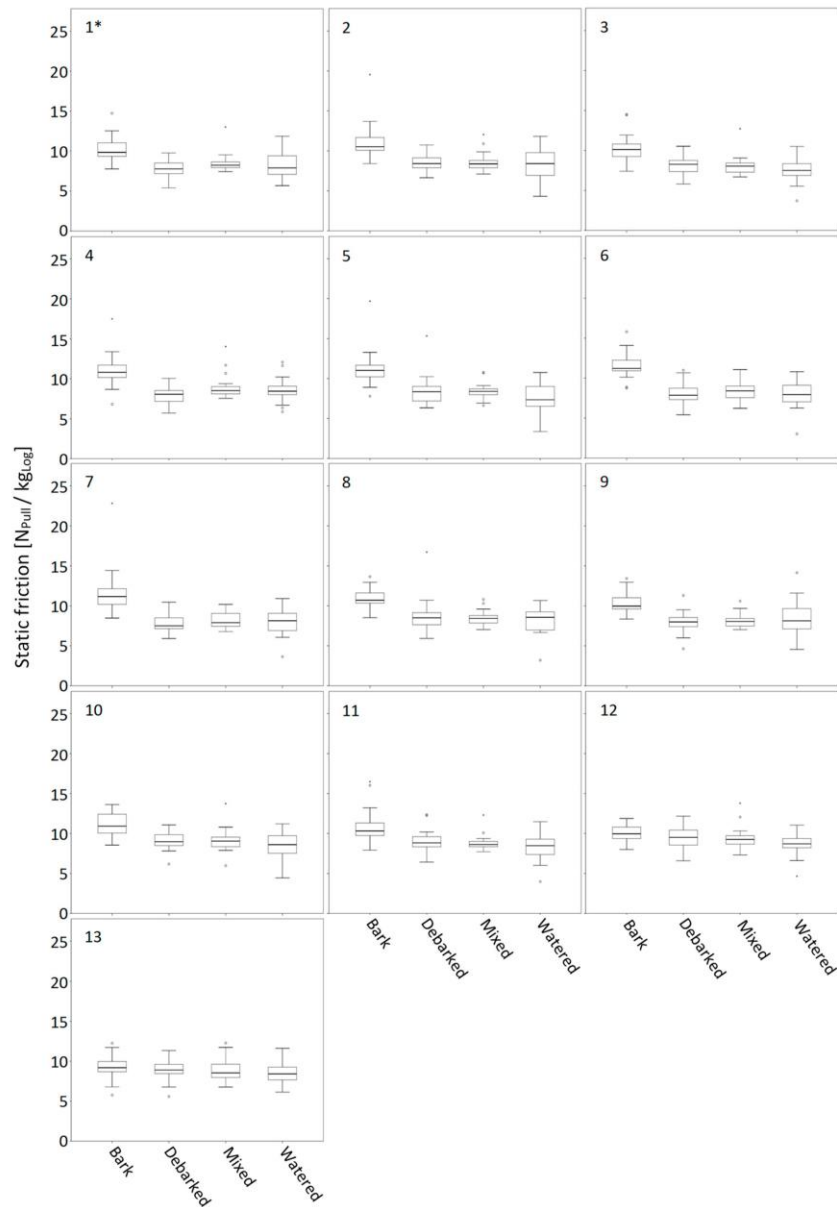
**Figure 8.** Boxplots showing the overview of the average static and sliding frictions in  $N_{Pull}/kg_{Log}$  of the four different treatments based on the 13 carried out test sessions.

### 3.4. Development of Static and Sliding Frictions Single Test Wise Comparison

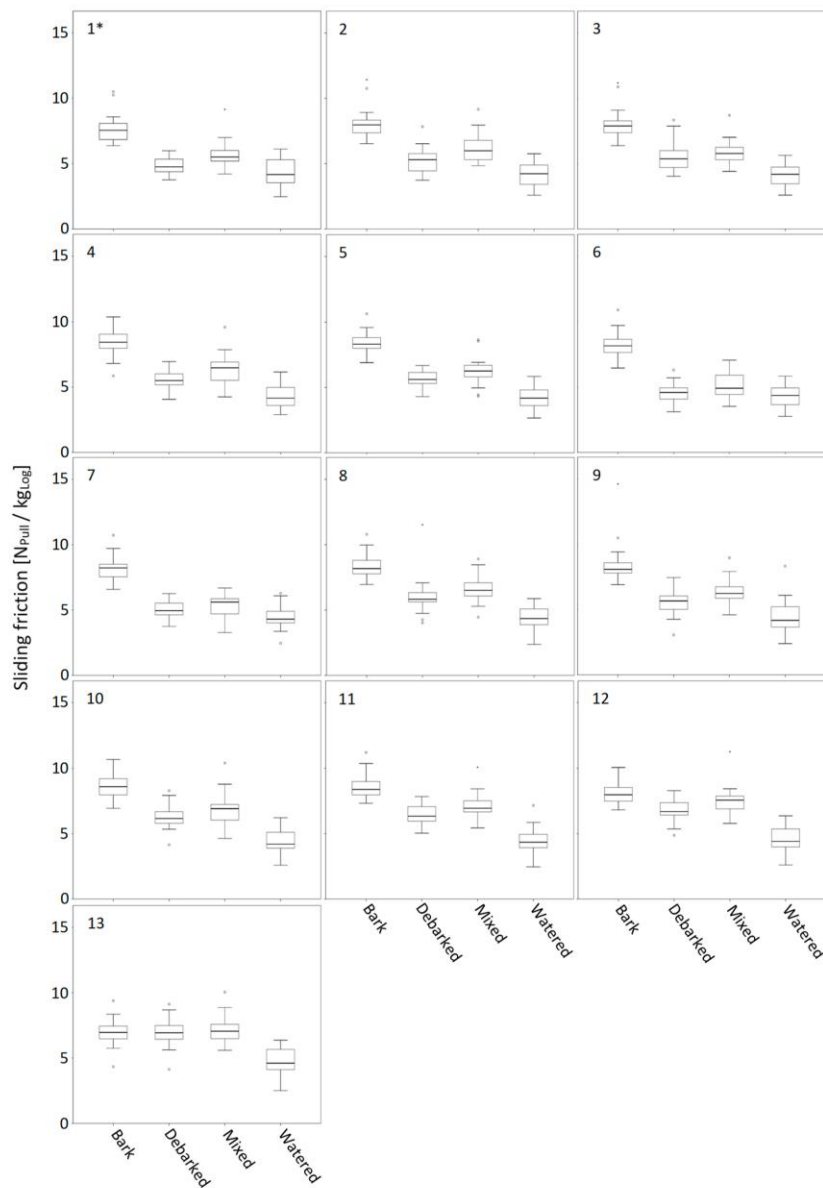
By calculating average static and sliding frictions over the complete test period, variations between the treatments and test sequences might be masked (Figure 8). Therefore, both static and sliding frictions were investigated separately for every test session and then compared among treatments. When focusing on static friction, no major differences developed within the seven-day monitoring period between the investigated treatments. One-way ANOVA and post hoc tests revealed no significant differences for the static friction between treatments that involved debarking (debarked, mixed, and watered). Average static friction of the bark treatment was significant higher throughout the first eleven tests, while the significant difference tended to decline towards test Nr. 12 (Figure 9). Within the twelfth test session occurring on day 7 however, no significant difference between the static friction of the treatments bark, debarked, and mixed was detected. However, a significant difference between the treatment bark and watered remained. This trend continued within the control test (Nr. 13) on day 21 illustrating no significant difference within all four tested treatments concerning the static friction. The tests also revealed that average static friction of all treatments increased within the 12 test sessions and then declined after 21 days (Table 1).

Investigations of significant differences between sliding frictions of the tested treatments, showed a higher variance of differences compared to the static friction (Figure 9). Six out of 13 test sessions showed significant differences between all four tested treatments (test sessions 1, 2, 4, 5, 9, and 11). Within all other test sessions carried out in the first seven days, significant differences were present between the treatments bark and watered (Figure 10). No significant difference was detected between

debarked and mixed, however, compared to bark and watered treatments significant differences were still present. Nevertheless, for the control test session of day 21, no significant difference was present between the treatments bark, debarked and mixed. Only the watered treatment performed on a significantly lower level when compared to the other treatments. In accordance to the static friction investigations, sliding friction increased over the test week but was lower for the measurements on day 21 (Test 13). In exception, the debarked treatment was presenting the highest measured average sliding friction within the test Nr. 13 (Table 2).



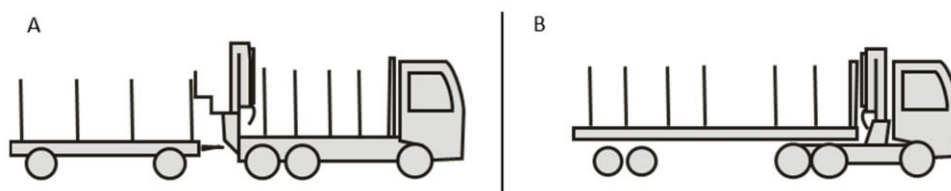
**Figure 9.** Development of static friction ( $N_{Pull}/kg_{Log}$ ) for each treatment throughout the 13 test sessions (\* test number).



**Figure 10.** Development of sliding friction ( $N_{\text{Pull}}/\text{kg}_{\text{Log}}$ ) for each treatment throughout the 13 test sessions (\* test number).

### 3.5. Influence of Debarking Treatment on Load Volume and Mass

To evaluate the influence of debarking on roundwood logistics, a calculation was performed to display the changes within load properties and management. Therefore, differences occurring by changing load volume and mass were calculated in an example considering the most commonly used truck and trailer systems for shortwood transportation within Germany (Figure 11). The transportation systems are either (A) a combined truck with loading space, self-loading crane and in attachment a simple trailer with comparable loading capacity or (B) a truck with self-loading crane and long trailer [19]. The technical machine characteristics and lorry dimensions are further displayed in Table 3.



**Figure 11.** Schematic display of (A) self-loading combined truck with short wood trailer providing a lorry length of  $2 \times 5.1$  m and lorry width of 2.27 m and (B) self-loading truck with long trailer and a lorry length of 13 m and lorry width of 2.4 m (adapted from [20]).

For the calculation of the maximum loading capacity, the maximum loading height of 2.4 m was used (Table 3). To consider the rather poor stacking ability of round logs and to address the free space (air voids) between single logs, a correction factor of 0.6 that is commonly utilized to calculate the stack volume was employed [21]. The legal maximum total mass of 44 tons for (A) combined truck and trailer system and 40 tons for (B) conventional truck and trailer system were considered as overall thresholds, referring to the German Schedule of Fines and Penalties [22]. Wood density ( $\text{kg}/\text{m}^3$ ) for bark and debarked wood was calculated from the log mass measured in the study (Figure 6). An average wood density of  $807 \text{ kg}/\text{m}^3$  (day 1),  $775 \text{ kg}/\text{m}^3$  (day 7), and  $673 \text{ kg}/\text{m}^3$  (day 21) was calculated for spruce roundwood of the bark treatment. For debarked spruce roundwood an average wood density of  $779 \text{ kg}/\text{m}^3$  (day 1),  $724 \text{ kg}/\text{m}^3$  (day 7) and  $564 \text{ kg}/\text{m}^3$  (day 21) was calculated.

**Table 3.** Machine-related characteristics and dimensions considered within the loading and mass capacity calculations.

Machine	Tare Mass [t]	Loading Capacity [t]	Loaded Mass [t]	Lorry Width [m]	Loading Height [m]	Lorry Length [m]	Load Volume Capacity [ $\text{m}^3$ ]	Correction Factor
(A) Truck	11.9	6.1	18.0	2.27	2.4	5.1	16.7	0.6
Trailer	4.9	19.1	24.0	2.27	2.4	5.1	16.7	0.6
(B) Truck	7.5		7.5					
Trailer	5.3	27.2	36.0	2.4	2.4	13	44.9	0.6

Results showed that a crucial overloading ( $>44$  tons) of the first investigated truck and trailer system (A) was impossible when loading Norway spruce shortwood. The highest calculated total mass of the fully loaded combined truck and trailer system accounted to 36.4 tons when loaded with barked roundwood assortments and 35.9 tons for debarked assortments, when considering the legal loading, technical conditions, and density of the logs used in the study. For the truck in system (A), load capacity of 6.1 tons turned out to be the limiting factor. When ignoring the legal load capacity of 6.1 tons and calculating with the maximum load volume capacity of  $16.7 \text{ m}^3$  for the truck lorry, total mass of the fully loaded truck and trailer system never exceeded the 44 tons legal threshold for all calculated scenarios. For the trailer, the load volume capacity of  $16.7 \text{ m}^3$  worked as limiting factor at all time. The presence of both limiting factors (mass and volume) resulted in a 1.1% additional  $\text{m}^3$  of transported debarked wood and cargo mass reduction of 2.3% per load on day 1, when compared to a full load of barked roundwood. This effect increased on day 2, resulting in a 2.2% increase in the volume of debarked roundwood transported and 4.4% lower cargo mass, thus culminating in an increase of 6.8% in transported debarked roundwood and a 10.5% reduction in cargo mass (Table 4).

Within the second calculated truck and trailer transport system (B), load capacity functioned as the limiting factor for days 1 and 7. This implied that overloading ( $>40$  tons) can occur when loading Norway spruce at the wood density measured in this study. The mass reduction through roundwood debarking resulted in a higher additional volume loading capacity of debarked roundwood when compared to a full load of barked roundwood. A potential additional net load of 3.4%, 7%, and 11% was calculated for days 1, 7, and 21 (Table 4), respectively. For the comparison of potential load mass



and volume, both factors limit the additional cargo, resulting in an additional load mass reduction of 6.9% due to the limit of loadable debarking roundwood volume.

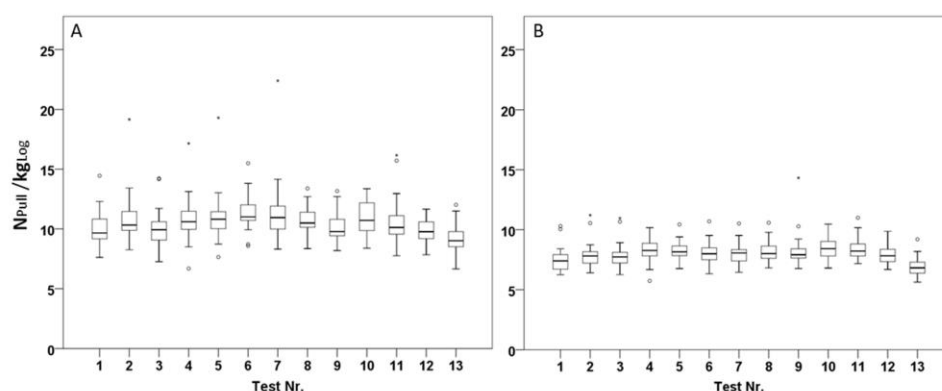
**Table 4.** Calculated differences between debarked and bark assortments concerning additional load and total mass of the loaded truck and trailer combination, after different drying periods.

Machine	Day	Additional Loaded m <sup>3</sup> [%]	Cargo Mass Difference for Full Loaded Lorry Bark/Debarked [%]
A) Truck/Trailer 2.4 m max. load height	1	1.1%	−2.3%
	7	2.2%	−4.4%
	21	6.8%	−10.5%
B) Truck/Trailer 2.4 m max. load height	1	3.4%	0%
	7	7%	0%
	21	11%	−6.9%

## 4. Discussion

### 4.1. Study Design and Measurement System

Overall, the study design operated as expected but some modifications to the VDI guideline were required to ensure good practicability. Specifically, the pulling speed was increased to be able to perform the intended amount of measurements per test session and day. Hence, the pulling length and resolution of the measurements were also increased to accommodate the faster pulling speed and to assure that local distortion factors such as branches or poor shape structure did not influence the full pulling attempt. It was initially planned to pull the logs three times over the full length of 50 cm and reposition the log after each pull. However, after preliminary testing, this method was abandoned because of possible wear-off on the outside surface of the logs over repeated measurements. Instead, it was decided to pull the log for 10 s (equaling to a horizontal distance of 16.7 cm) with 200 Hz producing 2000 single measurements per pulling attempt for three consecutive pulls, before repositioning the logs for the next test session. These settings proved to be beneficial as small disturbances were recorded with a higher resolution and tension problems within the pulling and measurement setup were not problematic within the data evaluation. The wear-off, especially on the bark treatment, did not show any negative influence. As presented in Figure 12, both static and sliding frictions increased over the test sessions instead of decreasing if surface wear-off would be a dominant factor. The decline for the last three test sessions might be explained through mass loss as also the mixed treatments showed no trend of influencing wear-off towards the later tests (Nr. 11, 12, and 13).



**Figure 12.** Development of (A) static and (B) sliding frictions ( $N_{\text{Pull}}/\text{kg}_{\text{Log}}$ ) within the bark treatment displayed over all test sessions.

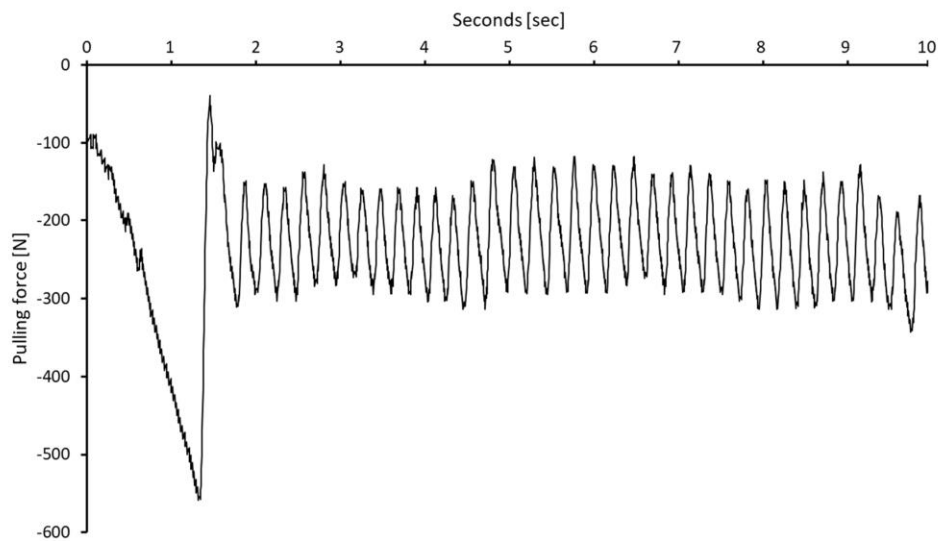
The measuring unit was solid and adequate for the mass of logs used and pulling forces measured. With its 860 kg, the electric forklift did not move laterally even during high pulling forces up to 1177 N. However, the interface between the palette and the winch, secured through a 5 mm diameter bolt, did show minor tension disturbances through bending processes during high pulling forces. Further studies could use a hydraulic cylinder system to apply a smoother pulling force, as used within a study setup in New Zealand in 2004 [23]. However, a hydraulic cylinder system would require a stronger fixation point and because of its weight it is rather complicated to move, and was therefore not ideal for our research.

A further deviation factor besides the tension within the measurement setup was expected to be the weather. Because of the extent of the test setup, logs had to be placed outdoors. This exposed the logs to differing weather conditions, such as temperature, air humidity, wind, and solar radiation. As those factors appeared to be similar for all tested treatments, deviations caused by weather did not show major distortions but also could not be completely eliminated. Therefore, it seems suitable to perform such measurements under controlled conditions within a building or test hall. As water proved to have a considerable influence on the sliding friction by lowering the adhesion (Figure 8), it would have been interesting to investigate the influence of water and rain on the bark treatment as well. For future studies, the mixed treatment could therefore be replaced by a watered bark treatment to improve the comparability and further investigate the influence of water on the static and sliding frictions of bark logs.

The test setup was designed to assure the highest comparability between the four treatments and to answer the question how debarked roundwood needs to be treated for load safety when compared to bark roundwood. This approach makes use of the drivers' experience of load safety for bark roundwood and the ability of transferring this knowledge onto debarked operations. To monitor the basic static and sliding frictions, all influencing factors, e.g., mass, diameter, log length, and surface contact would need to be investigated by testing different logs with varying log characteristics.

#### 4.2. Static and Sliding Frictions

The investigation of the mass development presented a 45% higher drying rate for the debarked treatment as compared to the bark treatment. In comparison, the mixed treatment presented an even higher mass loss over the testing period. This can be explained by the fact that the measured logs were also debarked and placed on bark support logs. Therefore, the drying procedure was identical to the debarked treatment, but were further placed in a less wind protected area and having a lower influence on the surrounding moisture content as the support logs were covered with bark and hence released less moisture into the air. Furthermore, the debarked treatment was located next to the watered treatment and an influence from the water application could not be completely excluded. The watering of the watered treatment also revealed another effect. Due to the sap remnants, the surface of the debarked logs started to become sticky and slippery at the same time resulting in a rather high static friction with a low sliding friction. This effect is called the "stick and slide effect", whereas no smooth pull of the logs was possible (Figure 13). This made a reliable calculation of the sliding friction rather difficult. The influence of the water also resulted within a weaker correlation coefficient between the log mass and the pulling force (Figure 7). After 21 days, the effect of the water was not as dominant as compared to day 7. This can be explained by not watering the logs throughout the additional 14 days between the last two test sessions. Hereby, logs were able to perform on par with the debarked and mixed treatments. However, the negative influence was still detectable within the drying rate compared to the debarked and mixed treatments (Figures 6 and 7).



**Figure 13.** Example of a typical pulling force measuring curve of the watered treatment, with stick and slide effect.

In total, the sliding friction was 24% lower for the bark treatment and 33% lower for the debarked treatment as compared to the static friction. Average values of 8.3 N/kg for the static and 5.6 N/kg for the sliding frictions are comparable to results obtained in New Zealand in 2004 [23]. Within the study [23], the friction and load characteristics of completely debarked loads regarding the restraint type, tension method on different tilt angles, and break tests were investigated. Further comparable pulling tests were carried out to assess the static and sliding frictions. All tests were performed using loaded trailers or stanchions. As no considerable differences within the frictions between both studies appear, results within our study once more indicate a strong suitability to draw direct conclusions for German load safety. However, for load safety, the lower sliding friction needs to be considered. It cannot be assured that a higher static friction is not denied by vibrations or road surface roughness that is distributed into the loaded assortments. Therefore, the sliding friction becomes the important value for load safety. Based on the compared results of the different treatments, it can be stated that for load safety, the debarked logs have to dry for a certain period of time before they should be transported. For this study, a full week with cold and windy weather appeared to be sufficient and after 21 days no significant differences were present compared to bark logs. However, the weather dependency of the drying rate makes it impossible to provide a fix drying time before debarked logs can be handled similarly to bark logs. Due to the stick and slide effect that reduces sliding friction, rain can have a negative influence on load safety as well. Therefore, additional features to secure the load should be considered when transporting wet debarked roundwood. Nevertheless, it needs to be stated that for the utmost of incidents with lost loads on the road as mentioned within the introduction, load security was usually not the cause of the incident unlike overloading, tiredness, mechanical failures or traffic.

#### 4.3. Load Mass and Volume

Investigations on the combined truck and trailer system (Figure 11A) showed that the limiting factor concerning the trailer appeared to be the load capacity (volume) instead of the load mass for both debarked and bark roundwood. Therefore, at day 1 the trailer could have been loaded with 23.7 m<sup>3</sup> (bark) and 24.5 m<sup>3</sup> (debarked) spruce roundwood but was limited to 16.7 m<sup>3</sup> of loading capacity. The additional loaded m<sup>3</sup> roundwood originated from the characteristics of the truck capacity (A). The truck is theoretically also limited to a loading capacity of 16.7 m<sup>3</sup> but the threshold was the 6.1 tons of

legal load mass. Therefore, debarking has an influence on both total load mass and total load volume, as the mass of the wood is reduced by a faster drying rate, a higher share of additional  $\text{m}^3$  of wood can be hauled by the truck itself. At the same time, the mass of the load on the trailer decreases with every drying day. Based on that higher drying rate, the total mass and therefore the wear-off (brakes, tires, bearings, transmission, compressed air system, chassis, etc.), fuel consumption and handling, uphill drive, and ground pressure per load could be improved. In addition, the impact onto the loading crane and hydraulic system is also expected to be lower, therefore contributing to a decreased wear-off. This effect might be even higher, as the correction factor of 0.6 is usually used for calculations without bark. A different correction factor for bark wood loads could hence result in a further decreased net load. However, as those factors are highly influenced by physical factors such as stem diameter and curviness, a fixed value was chosen to assure comparability within the hypothetical load calculation.

The second truck and trailer system (Figure 11B) offered a larger potential loading volume. Therefore, the mass of the logs became significantly important for the calculation of the possible total hauled  $\text{m}^3$  roundwood per single load. The higher drying rate of debarked roundwood was beneficial by allowing up to 11% additional  $\text{m}^3$  loaded wood when compared to a full load of barked wood. For day 21, the log mass decreased to an extent such that for a full load, volume became the limiting factor. However, 11% additional load could be hauled if logs are debarked and stored within the forest for a longer period of time, thus reducing the load mass by an additional 6.9%. When considering the necessity to transport the wood out of the forest within the first seven days to prevent the potential threat of the stored logs as spruce bark beetle breeding habitat within the forest stand and therefore calculating with the log mass of the bark treatment on day 7, this effect would even raise to 28% additional load. The debarking of logs therefore offers a great potential for both forest health and lower transport costs for future operations as up to 30% of the transport costs are related to fuel costs [24]. Therefore, it is assumed that fuel consumption  $\text{l/m}^3$  would benefit greatly of in-stand debarking.

An additional benefit of a potential higher load volume capacity is linked to the fact that overall transport capacity of the logistic sector in Germany cannot fulfill the actual demand. This is particularly the case for the forest sector [24]. A higher load capacity per truck could therefore help distributing the time pressure within the wood logistic chain while reducing the dormant threat of a crucial overloading [25].

## 5. Conclusions

The focus of this study was to assess the difference between bark and debarked roundwood assortments according the static and sliding frictions, and to suggest improvements concerning load safety. In comparison, both static and sliding frictions proved to be higher favoring bark logs. Conversely, the drying rate over the monitoring period was up to 45% higher for debarked assortments. As log mass proved to be the dominating factor influencing the required pulling force, significant differences between bark and debarked logs decreased within 7 days and were not detectable after 21 days. This leads to the assumption that debarked logs could indeed pose a higher threat on load safety if the material is transported directly after harvesting and debarking. However, when considering the drying rate depending on exposition, wind, air humidity, etc., debarked logs monitored in this study could be handled similarly to bark logs, when stored over a sufficient period of time greater than seven days. This time can vary greatly depending on the above-listed predominant surrounding factors.

Simulated rainfall had a negative influence on the sliding friction even after a long drying period. Therefore, additional load safety precautions (lashing straps or chains) should be considered when transporting debarked roundwood in wet weather conditions. It is also important to mention that good practice guidelines on load security (orienting large diameters towards the driving direction, contact with at least two stanchions on both sides, sufficient lashing straps, and no overloading) remain essential to safely transport bark or debarked roundwood.

The increased drying rate and associated mass reduction through debarking resulted in either a lighter total loading mass or a higher net load volume, both potentially reducing the wear-off and fuel consumption per transported m<sup>3</sup> wood. This effect shows the potential of reducing the carbon footprint of wood products even further in future, supporting the efforts towards a sustainable resource supply of forest products.

**Author Contributions:** Conceptualization, all authors; methodology, J.B.H.; writing—original draft preparation, J.B.H. and E.R.L.; writing—review and editing, all authors; supervision, E.R.L.; funding acquisition, S.W.

**Funding:** This research was funded by the German Federal Ministry of Food and Agriculture (FKZ 22012214).

**Acknowledgments:** We would like to thank Alois Reichenberger for his help with the preparation, execution and recording of the test measurements. Further, we want to thank Anton Brumer, Christian Genser, and Tilman Zepf for their assistance with the test setup and wood acquisition. Finally, we want to thank Lothar Zimmermann (LWF) for providing the weather data.

**Conflicts of Interest:** The authors declare no conflicts of interest.

## References

1. Bundesverband Güterkraftverkehr Logistik und Entsorgung (BGL) e.V. (2019). Available online: [https://www.bgl-ev.de/web/mensch\\_umwelt\\_verkehr/verkehrssicherheit/verkehrssicherheit2.htm](https://www.bgl-ev.de/web/mensch_umwelt_verkehr/verkehrssicherheit/verkehrssicherheit2.htm) (accessed on 13 June 2019).
2. DEKRA Automobil GmbH. *Dekra Verkehrssicherheits Report 2018—Güterverkehr*; ETM Corporate Publishing: Stuttgart, Germany, 2018; 76p.
3. Statista Forst- und Holzwirtschaft. 161p. Available online: <https://de.statista.com/statistik/daten/studie/152173/umfrage/entwicklung-des-holzeinschlags-seit-dem-jahr-1998/> (accessed on 8 February 2019).
4. Jagelcak, J.; Gnap, J. Different measures for load securing create barriers in international road freight transport. *Arch. Transp. Syst. Telemat.* **2011**, *4*, 10–17.
5. Strauß, M. Unfall: Holz-Lkw verliert Ladung. *Volksstimme*. Available online: <https://www.volksstimme.de/lokal/salzwedel/unfall-holz-lkw-verliert-ladung> (accessed on 8 July 2019).
6. Abendzeitung. Holz-Lkw kippt auf A92 um—Lange Staus. *Abendzeitung München*. Available online: <https://www.abendzeitung-muenchen.de/inhalt.zwischen-erding-und-freising-lkw-unfall-auf-a92-behinderungen-bis-zum-mittag.88436ae0-9739-4713-8f6f-404916abfc44.html> (accessed on 8 July 2019).
7. Monaco, K.; Williams, E. Assessing the determinants of safety in the trucking industry. *J. Transp. Stat.* **2000**, *3*, 69–80.
8. Quinlan, M. *Report of Inquiry into Safety in the Long Haul Trucking Industry*; Motor Accidents Authority of New South Wales: Sydney, Australia, 2001; ISBN 1876958065.
9. Singh, S.P.; Antle, J.; Singh, J.; Topper, E.; Grewal, G. Load Securement and Packaging Methods to Reduce Risk of Damage and Personal Injury for Cargo Freight in Truck, Container and Intermodal Shipments. *J. Appl. Packag. Res.* **2014**, *6*, 6. [CrossRef]
10. McKinnon, A.C. The economic and environmental benefits of increasing maximum truck weight: The British experience. *Transp. Res. Part D Transp. Environ.* **2005**, *10*, 77–95. [CrossRef]
11. Jacob, B.; Feypell-de La Beaumelle, V. Improving truck safety: Potential of weigh-in-motion technology. *IATSS Res.* **2010**, *34*, 9–15. [CrossRef]
12. Zhang, P.; Nagae, T.; McCormick, J.; Ikenaga, M.; Katsuo, M.; Nakashima, M. Friction-based sliding between steel and steel, steel and concrete, and wood and stone. In *Proceedings of the 14th World Conference on Earthquake Engineering*, Beijing, China, 12–17 October 2008.
13. Koubek, R.; Dedicova, K. Friction of Wood on Steel. Master's Thesis, Linnaeus University, Växjö, Sweden, 2014. Available online: [http://www.diva-portal.org/smash/record.jsf?dswid=6017&pid=diva2%3A729796&c=8&searchType=SIMPLE&language=en&query=Friction+of+Wood+on+Steel&af=%5B%5D&aq=%5B%5B%5D%5D&aq2=%5B%5B%5D%5D&aqe=%5B%5D&noOfRows=50&sortOrder=author\\_sort\\_asc&sortOrder2=title\\_sort\\_asc&onlyFullText=false&sf=all](http://www.diva-portal.org/smash/record.jsf?dswid=6017&pid=diva2%3A729796&c=8&searchType=SIMPLE&language=en&query=Friction+of+Wood+on+Steel&af=%5B%5D&aq=%5B%5B%5D%5D&aq2=%5B%5B%5D%5D&aqe=%5B%5D&noOfRows=50&sortOrder=author_sort_asc&sortOrder2=title_sort_asc&onlyFullText=false&sf=all) (accessed on 26 June 2019).
14. Carroll, A.; Forster, B.; Hurling, R.; Nageleisen, L.M.; Ravn, H.P.; Weed, A.; Schroeder, M.; Grégoire, J.; Marini, L.; Økland, B.; et al. Climate drivers of bark beetle outbreak dynamics in Norway spruce forests. *Ecography* **2017**, *40*, 1426–1435.

15. De Groot, M.; Diaci, J.; Ogris, N. Forest management history is an important factor in bark beetle outbreaks: Lessons for the future. *For. Ecol. Manag.* **2019**, *433*, 467–474. [[CrossRef](#)]
16. Hinze, J.; John, R.; Delb, H. *Spreading Dynamics of the European Spruce Bark Beetle in the Black Forest National Park*; FVA Annual Report; Forest Research Institute: Freiburg, Germany, 2017; pp. 28–29.
17. Abschlussbericht. *Nährstoffentzüge bei Holzernte minimieren durch die Nutzung von entrindenden Harvesterfällköpfen (Debarking Head)*; Bundesministerium für Ernährung und Landwirtschaft: Bonn, German, 2018; 100p.
18. Verein Deutscher Ingenieure e.V. *Securing of loads on road vehicles—Determination of coefficients of friction. VDI 2700, Part 14*; Beuth Verlag: Berlin, Germany, 2011; 20p.
19. Korten, S.; Eberhardinger, A. *Entwicklungen Für den Rundholztransport. Logistik—Holz Kommt in Fahrt, LWF Aktuell 2008*; Bavarian State Institute of Forestry: Freising, Germany, 2008; Volume 65, pp. 16–18.
20. Erler, J.; Dög, M. Funktionsdiagramme für Holzernteverfahren. *Forsttechnische Informationen KWF* **2009**, *61*, 14–17.
21. Reisinger, K.; Höldrich, A.; Kuptz, D.; Hartmann, H. Poster: Umrechnungsfaktoren verschiedener Raummaße für Scheitholz. Technologie- und Förderzentrum im Kompetenzzentrum für Nachwachsende Rohstoffe. Available online: [www.tfz.bayern.de](http://www.tfz.bayern.de) (accessed on 8 July 2019).
22. German Federal Ministry of Transport and Digital Infrastructure. Schedule of Fines and Penalties. Available online: <https://www.bussgeldkatalog.org/zuladung-lkw> (accessed on 8 July 2019).
23. Baas, P.H.; Mueller, T.H.; Milliken, P. *Load Security Testing of Logs A Summary Report for the Log Transport Safety Council*; Transport Engineering Research New Zealand Limited: Manukau City, New Zealand, 2004.
24. Korten, S.; Eberhardinger, A. *Mehr Effizienz im Rundholztransport. LWF Aktuell 2008*; Bavarian State Institute of Forestry: Freising, Germany, 2008; Volume 65, pp. 12–13. ISSN 1435–4098.
25. Koirala, A.; Kizha, A.R.; Roth, B.E. Perceiving Major Problems in Forest Products Transportation by Trucks and Trailers: A Cross-sectional Survey. *Eur. J. For. Eng.* **2017**, *3*, 23–34.



© 2019 by the authors. Licensee MDPI, Basel, Switzerland. This article is an open access article distributed under the terms and conditions of the Creative Commons Attribution (CC BY) license (<http://creativecommons.org/licenses/by/4.0/>).