

Migration Strategies for FTTx Solutions based on Active Optical Networks

Kun Wang, Anders Gavler, Carmen Mas Machuca, Lena Wosinska, Senior Member IEEE, Kjell Brunnström and Jiajia Chen, Senior Member IEEE

Abstract—Active Optical Network (AON), one of the most deployed fiber access solutions in Europe, is facing the need to be upgraded in order to satisfy the ever growing bandwidth demand driven by new applications and services. Meanwhile, network providers want to save both Capital Expenditures (CAPEX) and Operational Expenditures (OPEX) to ensure that there is profit coming from the investments. This paper proposes several migration strategies for AON from data plane, topology, and control plane perspectives, and investigates their impact on the Total Cost of Ownership (TCO).

Index Terms— Active Optical Network (AON), Fiber To The x (FTTx), migration, node consolidation, Next Generation Optical Access (NGOA), Software Defined Networking (SDN), techno-economics

I. INTRODUCTION

OPTICAL fiber communication, as a future proof technology, has its unique advantages of delivering ultra-high capacity. It has been widely deployed in the telecommunication core and aggregation networks for several decades. Fiber To The X (known as FTTx, where x stands for home, building, curb, node, etc.) has also started all over the world. There have been more than 93 million FTTx subscribers in Asia, 12 million in the USA and 20 million in Europe [1]. The most common FTTx solutions deployed today are Active Optical Network (AON) and Time Division Multiplexing (TDM) Passive Optical Network (PON). AON, also known as

This work was supported in part by VINNOVA (The Swedish Governmental Agency for Innovation Systems) through Kista 5G transport lab, and the European Community's Seventh Framework Program (FP7/2007-2013) under grant agreement n° 249025 (ICT OASE).

K. Wang is with KTH Royal Institute of Technology and Acreo Swedish ICT, Stockholm, Sweden (kunw@kth.se).

Prof. L. Wosinska and Prof. J. Chen (corresponding author) are with the Optical Networks Lab (ONLab), KTH Royal Institute of Technology, Sweden.

Dr. C. Mas Machuca is with Chair of Communication Networks in the Institute for Communication Networks (LKN), Technische Universität München (TUM), Germany.

A. Gavler and Prof. K. Brunnström are with Acreo Swedish ICT, Stockholm, Sweden.

active Ethernet has been standardized [2], and it is the most deployed FTTx solution in Europe. At the mid of 2012, it represented 78% of market share [3], giving it a high technology penetration already in Europe.

There are two variants of AONs: Point-to-Point (PtP) and Active Star (AS), both of which are based on active Ethernet switches. The PtP is also referred to as homerun (shown in Fig. 1(a)), where each subscriber has a dedicated fiber connection between the Residential Gateway (RG), namely Optical Network Terminal (ONT) (in case of the Fiber To The Home (FTTH)) and the Ethernet switch with Optical Line Terminal (OLT) located in the Central Office (CO). Unlike the PtP, the AON AS has a point-to-multipoint topology, employing active Remote Node (RN) connecting the CO and multiple households (as illustrated in Fig. 1(b)). The RN can be located either in a cabinet or inside the building, e.g., a basement of a multi-dwelling unit. The Ethernet switch at RN aggregates the traffic from a group of subscribers, and is connected by a feeder fiber to another Ethernet switch at the CO. Two or more feeder

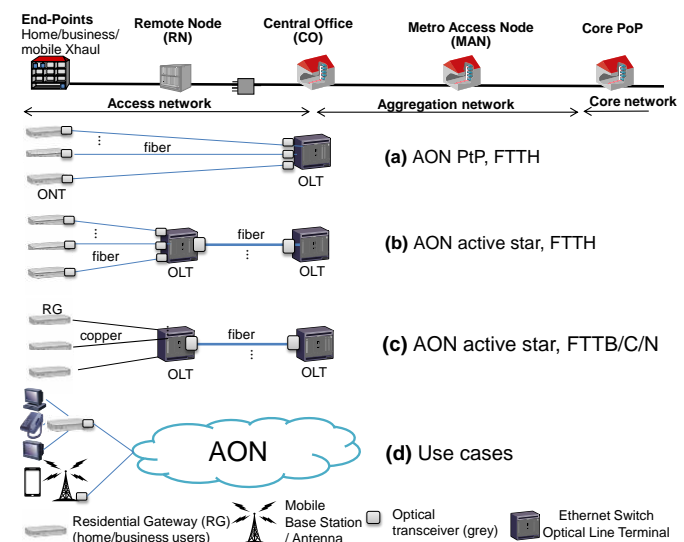

Fig. 1 Current AON solutions for FTTx

fibers can be deployed to provide resiliency, but the amount of fibers used in the AON AS architecture can be significantly reduced compared to the PtP case. Fig. 1(c) shows a FTTB/C (Fiber To The Building/Curb) based on AON AS. The optical signals are terminated at RN, which is connected to the households via legacy copper cables.

AON deployments have already begun to offer 1 Gbps per subscriber [4]. However, the earlier and more common deployments of AON solutions offer lower data rates, e.g., up to 100 Mbps per ONT. Besides serving residential users, AON can support backhaul/fronthaul (Xhaul) for mobile networks, and broadband services for business users, as shown in Fig. 1(d). The emerging services, such as ultra-high definition TV, video conferencing, cloud services, 4G/5G mobile Xhaul, etc., are gradually eating up bandwidth of existing networks and driving capacity demands beyond 100 Mbps. Therefore, proper migration strategies towards solutions capable of delivering the new demanding services are highly required. Furthermore, the incentive of operators/providers for migration is also related to their willingness to achieve Total Cost of Ownership (TCO) savings by reducing Operational Expenditures (OPEX).

Different Next Generation Optical Access (NGOA) network technologies have been extensively investigated during the past years. Wavelength Division Multiplexing (WDM) is widely recognized as a promising technology to increase the bandwidth in FTTx. Paper [5] compared the cost and performance of different types of WDM based PONs, including Time and Wavelength Division Multiplexing (TWDM)-PON, Wavelength-routed WDM-PON and Ultra-Dense WDM-PON. It has been shown that for high bandwidth demands (beyond 500 Mbps per customer) WDM technology becomes most efficient for capacity upgrade. Recently, ITU-T also approved the second Next Generation Passive Optical Network (NG-PON2) standard [6], where the primary technology is TWDM-PON. A complete cost evaluation of network migration starting from GPON to TWDM-PON was carried out in Paper [7], in which the result shows that migrating to TWDM-PON is the best option thanks to its high sharing rate while providing high bandwidth on a per-user basis. Meanwhile, node consolidation has been considered as an important trend for access network migration driven by the operators/providers because of a high potential for the TCO savings. Papers [5] and [7] indicate clear cost advantages of node consolidation due to better utilization of aggregation networks. All aforementioned studies have a strong focus on the evolution of data plane technologies. However, the other important aspects of network architecture, such as topology and control plane, have not been addressed. In recent years, there has been increasing interests in the concept of Software Defined Networking (SDN). It separates control plane from traditional network equipment, and migrates towards logically centralized control plane architecture, according to Open Networking Foundation (ONF) [8]. Many vendors and operators/providers have foreseen great advantages of using SDN to simplify network control and management (C&M). For example, paper [9] investigates the applicability of SDN to a Gigabit-capable PON based FTTH network. AON is fully

based on IP/Ethernet technology, so the applicability of SDN to AON is quite straightforward. However, the impact on TCO and benefits from migration towards SDN enabled by AON are rarely studied.

A comprehensive view of network architecture should include various aspects, such as data plane, control plane and network topology. In contrast to the existing work, we take into account all these three aspects, concentrate on AON and systematically investigate possible migration strategies from current AON deployment to NGOA networks.

The remainder of this paper is organized as follows. In Section II several cost related aspects are listed, which later on are used as key parameters for high-level evaluation of the considered migration strategies. Sections III, IV, and V address migration strategies from three different perspectives, namely data plane, topology and control plane. Finally conclusions are drawn in Section VI.

II. NETWORK MIGRATION COSTS

From network operators'/providers' perspective, besides the demands of upgrading the network capacity to satisfy the bandwidth demand of emerging services and expand the network coverage to accommodate more customers, the other major goal of network migration is to achieve higher profits. Therefore, when planning a network migration, operators need to evaluate both the required new investment (CAPEX) and the potential OPEX saving.

A. CAPEX

Migration from an old platform/technology to a new one inevitably requires new investment. In order to benefit from the migration and achieve maximal return on investment, operators/providers want to minimize the discounted payback period, while keeping CAPEX as low as possible. CAPEX refers to any costs related to the infrastructure and equipment that need to be purchased and installed before the network becomes operable. The major CAPEX for the access network can be divided into three categories:

- Fiber infrastructure
- Network equipment
- Residential gateway

Fiber infrastructure in access network embraces all fiber related costs such as duct, fiber cable, trenching, splicing, installations, power splitters, wavelength filters etc. It is normally the most expensive part in the FTTx deployment especially when trenching is required [5]. Therefore, the key factor to minimize the CAPEX of a network migration is to reuse the existing fiber infrastructure as much as possible.

The investment in next generation network equipment refers to the costs of any active equipment to be placed in the Metro-Access Node (MAN), CO, as well as RN, e.g., Ethernet switches, OLTs. In some cases, WDM filters are integrated together with OLTs and therefore, the cost of these passive components are considered as a part of the OLT cost.

The RG related costs is one of the most important parts of the CAPEX paid for network equipment [10]. Migration to the next generation network may require the replacement of all RGs at

subscribers' premises due to the changes of the data plane technology and capacity. In that case, the replacement of RGs is also one of the key aspects for the network migration.

B. OPEX

Another aspect that should be evaluated when considering the gain of a migration strategy is the OPEX reduction of the new network compared with the legacy platform. OPEX refers to any costs required for the operation of the network. The major OPEX components are:

- Energy consumption
- Service provisioning
- Fault management and maintenance

From a network operator/provider point of view, the OPEX related to energy consumption refers to the electricity bill for powering and cooling network equipment. The energy consumption of RG is excluded here, because it is usually paid by the subscribers

Service Provisioning (SP) is the cost associated to any activities related to adding, changing and cancelling customer services (e.g., network and service configurations, fiber patching at different locations for connecting a new customer or new services, provider change, user move). Many factors have impact on the SP cost, such as, the required fiber and equipment, the possibility of remote configuration, human resources and travelling, etc., needed to connect a new customer or changing the services.

OPEX related to the Fault Management (FM) is the cost associated with the detection and reparation of any failure in the network including both equipment and infrastructure. The FM process includes the failure detection, help desk, opening trouble ticket, reparation of the failure, travelling to the failure locations and required human resource. The maintenance comprises all tasks which are required to keep the network up and running. This includes software and hardware upgrades, personnel inspections, performance monitoring, inventory management, etc.

III. DATA PLANE MIGRATION

In this section, we investigate migration strategies considering node consolidation approach from the data plane perspective, taking into account the characteristics of existing AON deployments.

A. Node consolidation

The motivation for node consolidation is to reduce the number of COs, so that the costs associated to those nodes, e.g., housing, energy and maintenance, can be saved. All network equipment will therefore be moved to the MAN allowing supporting much more end-users and serving larger areas than the current CO.

Fig. 2 shows a proposed migration path from current AON PtP to WDM-PON [5] where WDM technology is recommended to avoid costly additional trenching over a long distance in aggregation network. In the case of node consolidation, a number of COs are supposed to be closed down to save the costs, therefore all active network equipment have to

be moved into a MAN. Wavelength filters (Arrayed Waveguide Gratings, AWGs) are placed in the location of traditional COs to replace the AON PtP switches. The AWGs are passive components and they can be installed either underground or in a cabinet, where electrical power is not needed. The AWG multiplexes the wavelength coming from a number of customers into one feeder fiber, which connects to the WDM-PON OLT (Ethernet switch with another AWG and colored optical interfaces). Every user connected to the AWG is assigned a dedicated wavelength from the OLT.

For the existing AON AS, a proper data plane migration option can be towards a fully passive solution, e.g., TWDM-PON, which is defined by ITU-T (see [6]) as a primary technology for NG-PON2. In this case, the active RNs are replaced by passive power splitters, while the Ethernet switches at the old CO location are replaced by AWGs (see Fig. 3). Therefore, both RNs and COs can be potentially eliminated to support node consolidation.

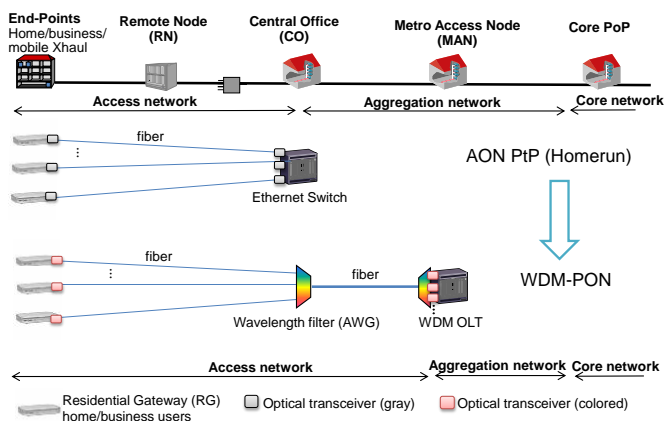

Fig. 2 Migration from AON PtP to WDM-PON with node consolidation approach

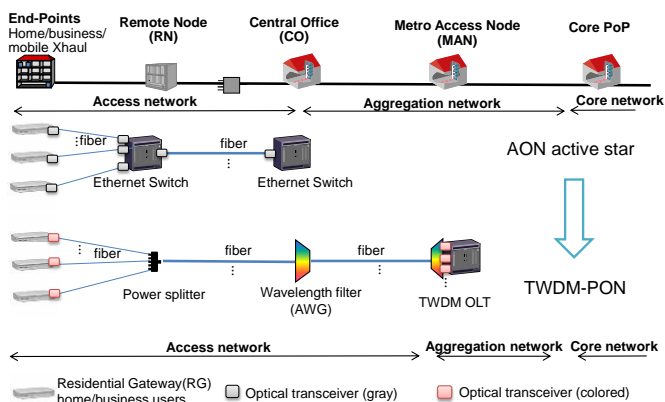

Fig. 3 Migration from AON active star to TWDM-PON with node consolidation approach

B. Costs evaluation

1) CAPEX

From the fiber infrastructure perspective, both WDM-PON and TWDM-PON have the advantage of reusing existing fiber infrastructure from legacy AON, and therefore a large part of CAPEX can be saved. The fiber connection between CO and MAN may also require additional investment if it is not

available from the legacy network. However, thanks to the WDM technology, the additional amount of fibers required for network upgrade can be reduced. They can be installed in the existing ducts, and thus the huge trenching costs can be avoided. There are some fiber splicing and reconnection work involved at COs and RNs. Migration path from AON PtP to WDM-PON can be realized by reconnecting fibers at COs, while migration from AON AS to TWDM-PON requires fiber reconnection at both RNs and COs. AWGs have to be installed at COs and MANs for both migration paths, and active RNs need to be replaced by power splitters.

Both migration paths require the investment in network equipment such as OLTs (including optical transceivers) at MAN. At customers' side, replacement of RGs/ONTs is required in order to adapt to WDM or TWDM technologies. When replacing the active equipment at CO and RN with passive devices, the cost of closing down the sites and moving the active equipment to MAN may be substantial. Regarding the coexistence, passive solutions cannot coexist with legacy AON, and therefore cannot run simultaneously on the same fiber infrastructure in the case of the both presented data plane migration paths (i.e., from P2P to WDM-PON and from AON active star to TWDM-PON).

2) OPEX

The aim of node consolidation approach is to save OPEX by reducing the number of COs.

Reducing the number of COs will probably not significantly change the overall energy consumption [11]. The energy that network and cooling equipment consume is mainly dependent on the number of customers and the amount of traffic carried by the equipment. It is because the node consolidation only reduces the number of access nodes, while the amount of the active network equipment is unchanged, as it is either moved to the MAN or replaced by new equipment at MAN. Therefore, a large portion of CO power consumption is shifted to the MAN.

In the current AON PtP networks adding or changing customers' subscriptions requires technicians to travel to the COs, manually add/remove fibers, and install new switches if needed. In AON AS case, technicians need visit RNs (sometimes both RNs and COs) to perform the tasks. There is a large number of distributed COs and RNs in the network. Therefore SP in current networks may involve a high cost of human resources. When AON PtP and AS are migrated to the consolidated WDM-PON and TWDM-PON respectively, only passive components are at COs and/or RNs. The technicians are normally placed in the MAN locations*, and there is no need for human involved work at COs. Consequently, the costs associated with travelling and human resource can be reduced significantly.

The decommission of traditional COs can reduce the overall effort for the FM, maintenance and administration of the building infrastructure including cost of renting, cleaning, gardening in the outside area if any, heating, renovations,

insurances, etc. The WDM-PON and TWDM-PON do not require any active network equipment in the field, which simplifies maintenance of the network. Consequently, FM and maintenance processes are less time consuming and hence the cost of human resources can be saved. However, under some circumstances, COs cannot be completely closed down because they are still used for the other purposes (e.g. telephone networks, Content Delivery Networks (CDN), or regulatory reasons). In such cases, the maintenance and other operational cost reduction may be limited. Another important issue in node consolidated network is the node failure. Due to a large number of subscribers connected to a single node, any failure (e.g., power supply fault at MAN) can simultaneously affect many customers. Therefore, efficient FM and resiliency mechanisms are required to avoid service interruption for a large amount of customers. This can be potentially addressed through topology migration that is introduced in next section.

IV. TOPOLOGY MIGRATION

In contrast to tree, mesh/ring topology has better connectivity and offers better resiliency and traffic locality (which is defined as the ability to keep traffic locally in order to offload metro/core network [12]), so that the network performance and Quality of Experience (QoE) of end users can be greatly enhanced. Some operators/providers have already started building their fiber access network with the mesh/ring topology, e.g., [13].

A. Mesh/ring topology

Legacy telecommunication network is designed to deliver traditional Internet services that cannot match today and future service requirements (e.g., CDN, 4G/5G Xhaul). Therefore network operators/providers are trying to build or redesign networks in order to address this problem, while minimizing the TCO by sharing network equipment, fiber infrastructure, housing and maintenance.

The increasing bandwidth demand from the end-points (including fixed broadband users and cells for radio access networks) combined with a high customer density, leads to a huge amount of data traffic towards the aggregation and core network. It increases core network load and energy consumption, and consequently, may degrade the network performance. This problem becomes more severe in case of the bandwidth-demanding video content distribution. Local caching of content [12], has been proposed to address this problem. The mesh/ring topology suits better the CDNs, taking advantage of the distributed nodes that are close to the end-users, and making use of high connectivity to share caches among neighboring nodes.

The resilience requirement is driven by the increasing demand on a reliable and high quality broadband infrastructure that are particularly important for business customers, mobile Xhaul, public services, healthcare, etc. From the resiliency point of view, the mesh/ring topology is better than PtP/star/tree. If failures occur, alternative disjoint paths can be easily found in most of the cases, and hence the impact of the failures can be reduced. In contrast, in a star/tree topology, the

* Private communication with Deutsche Telekom within EU-FP7 OASE project, www.ict-oase.eu

failure of centralized node can have very high impact due to a large number of connected subscribers.

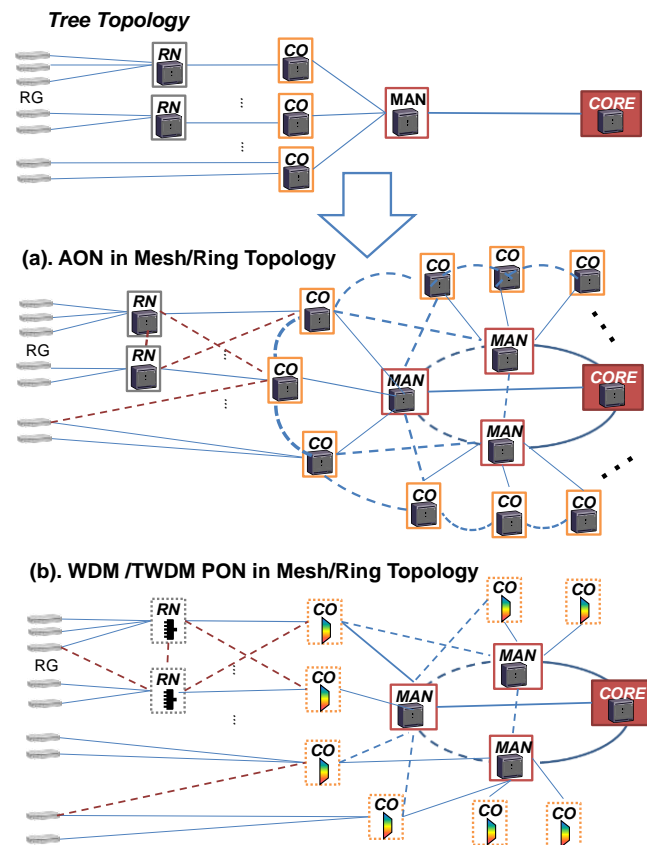

Fig. 4 Migration from tree to the mesh/ring topology (where dashed lines refer to fiber links added for topology evolution)

Fig. 4 (a) illustrates AON migration from tree to mesh/ring topology. The mesh/ring topology migration keeps all existing AON nodes and fiber connections (solid lines in figure), and adds more connections between the nodes, so that the new network topology becomes mesh/ring. The dashed lines in the figure show examples of the potential links that can be added. The migration towards mesh/ring topology not only improves network resilience by adding node and link protection, but also enhances traffic locality. Furthermore, from the end-users' point of view, the QoE can be improved by traffic locality, e.g., shorter downloading time, smooth video play out. Fig. 4 (b) shows an example of combination of data plane and topology migrations, i.e., node consolidated WDM/TWDM-PON with the mesh/ring topology. Besides interconnecting MANs in the mesh/ring, the additional links (e.g., the fibers between the RNs, and between the RGs and COs/RNs) can be added for resiliency purpose. In some of these cases, the housing of RNs and COs does not exist, as only passive components are located.

B. Costs evaluation

1) CAPEX

The CAPEX of the mesh/ring topology migration mainly involves adding new fiber connections between the nodes. It can be costly especially when the additional trenching is required. A good network planning can help to reduce these

costs. For example, the migration plan can be coordinated with CDN deployment, where the new connections between neighboring nodes would be already provided around the caching locations. Enhanced reliability performance can be offered in the first place for the important customers, e.g., business users, healthcare, mobile backhaul, that are willing to pay extra for higher quality of service.

There are no significant changes required for network equipment and RGs in the case of topology migration. However, in order to have very high reliability performance (including protection for the last mile), redundant equipment and optical interfaces are needed. For some end-points requiring ultra-high connection availability (e.g., higher than 4 nines), two optical interfaces are necessary in order to have an end-to-end protection. For WDM/TWDM-PON there are costs of upgrading the passive splitters and filters from 1:M to 2:M in order to provide the feeder fiber protection.

2) OPEX

The potential benefits of mesh/ring topology come from traffic locality which can reduce the capacity required and energy consumed at higher aggregation nodes. In turn, the costs for the network operator/provider can be reduced. However, the power consumption in access network can be higher due to a number of distributed nodes. The links dedicated for resiliency purpose can be switched off if no failure occurs. On the other hand, it is at the expense of a longer recovery time.

In a mesh/ring AON, SP processes still requires technicians to travel to many distributed nodes and to add/remove links manually, while in a mesh/ring WDM -PON/TWDM-PON the need for SP processes exists only at MANs.

Regarding the FM and maintenance aspects, the mesh/ring topology can significantly reduce the impact of failure by the inherent resilience. The network will become less sensitive to the length of the repairation time. The additional equipment that needs to be installed for redundancy increases the maintenance and FM cost because it can also fail and then have to be repaired/replaced. On the other hand, service penalty, which is quite often paid to business customers due to the disconnection, can be dramatically reduced, since the risk of service interruption is much lower.

V. CONTROL PLANE MIGRATION

In this section we investigate the migration strategy in the control plane, which can be carried out together with the network evolutions in the data plane and topology introduced in the previous sections.

A. Migration strategies towards SDN

SDN separates the control plane from the traditional network equipment aiming at simplifying network operations, and managing the network in a cost-effective and flexible way [8].

One of the popular SDN architecture is shown in Fig. 5(a), where multiple SDN controllers are used according to different network domains and network services. A network orchestrator on top of all controllers coordinates their activities [14]. This

solution may fit better in a large network that includes many nodes and devices. The individual controller at each network domain is only responsible for the equipment within its domain. Therefore it has better performance in terms of security, response time, scalability, etc. However it may lose some flexibility and efficiency when it comes to cross domain application, since it needs coordination among different controllers. The use of separated controller is good for a network that involves different technologies (e.g., PON in access, IP/Ethernet in core), different service functionalities (e.g., broadband access for residential/business users, mobile Xhaul) or multiple network providers/operators.

An alternative control plane migration towards SDN-based network is shown in Fig. 5(b), where a logically centralized SDN controller is used crossing multiple network domains. A pool of controllers may be used when there are needs for resiliency and scalability. The controller itself acts also as an orchestrator that coordinates network resources across different domains and services. Since AON is fully based on IP/Ethernet technology which is also main technology today used in the home, enterprise, aggregation and core networks, it makes control plane of AON easier to be integrated with core/aggregation as a unified controller. The integrated controller has a global view of all network devices and the entire network topology, so that it can quickly and efficiently allocate the resources and find optimal path across the whole network. However when the network becomes larger (i.e., the number of network devices is high), it may bring issues on latency, security, etc. Therefore this solution may be suitable for operators that are running small or medium size networks, but covering access, aggregation and/or core segments simultaneously. Actually, many existing AONs, e.g., municipality networks, are run by small operators.

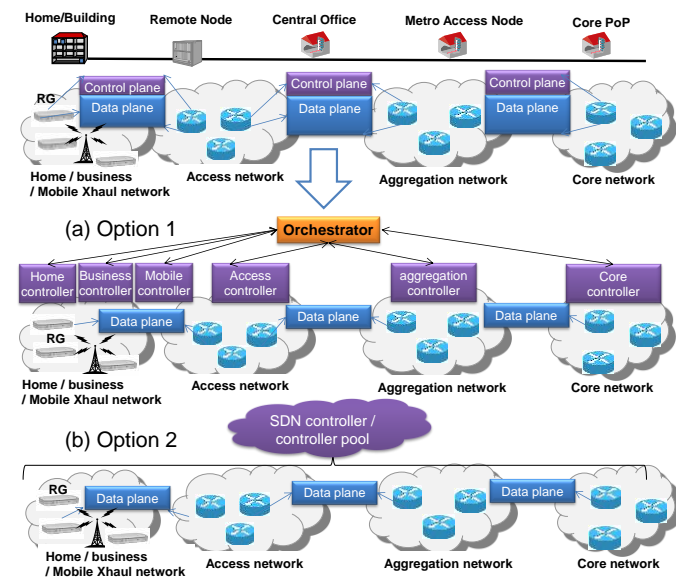

Fig. 5 Control plane migration towards SDN enabled network

B. Cost evaluation

1) CAPEX

From the CAPEX point of view, the major investment of this

migration path is purchasing and installation of SDN enabled network equipment (e.g., OpenFlow switches, controller, orchestrator). However, the cost of SDN enabled network equipment is expected to be lower than the current devices, since the sophisticated control plane and operation system are no longer needed in each individual network device. The controller consist of servers and software, and the cost is relatively low (some open source software [15] is also available). Thanks to the flexibility and programmability of SDN itself, the existing legacy network elements can be reused in the SDN-enabled network. Generally speaking, if migration is only carried out in the control plane towards SDN all legacy AON devices can be kept, including RG/ONT since it is an integration of Ethernet switch/router and optical terminal. However, additional software developments are needed in order to make the legacy device programmable for the SDN controller. For example, legacy switches commonly use certain C&M protocols, e.g., Simple network management protocol (SNMP). In the SDN controller a software plugin has to be implemented, so that the controller can control and reconfigure legacy devices through SNMP. In the OpenDayLight controller community [15], there are many working projects focusing on the development of such plugins. Although the reuse of existing network elements saves the investment in the hardware, replacing legacy equipment with SDN-enabled devices can bring more benefits, such as automatic network topology discovery, specialized and efficient packets forwarding mechanism, fast deployment and configuration.

2) OPEX

AON uses IP/Ethernet as data plane technology, while SDN has good compatibility with IP/Ethernet. Therefore, AON is able to realize simple control plane migration towards SDN-enabled network. With the help of SDN, the AON can optimize network C&M processes, and improves the network operation efficiency.

Thanks to the SDN programmability, the power consumption of the network can be potentially reduced through dynamic network resource allocation. For example, the controller/orchestrator can route and aggregate the traffic flows to a certain path according to the traffic conditions in the network, so that only a lower number of nodes involved, and thus it becomes more energy-efficient compared to the traffic flows distributed over many underutilized nodes. Some of the network elements can be switched off or put in a power saving mode by the controller/orchestrator during the periods when there is no or low traffic. The SDN orchestration among different service domains (mobile Xhaul, home/business broadband access) can improve network utilization and energy efficiency not only in the optical transport network, but also in the other network segments (e.g., radio access network)[14].

From the SP perspective, the cost of control plane migration from conventional AON towards SDN-enabled network mainly involves decommission of old C&M in the legacy network elements, upgrading and reconfiguring new SDN controllers, and provisioning new services. In the current networks, it takes a lot of time and human resources when network

operators/providers deploy new services or upgrade existing ones, e.g., where changes of policies, capacities, and routing rules are needed. The SDN controller provides an interface which allows deployment of applications/services on top of the infrastructure to automatically optimize and quickly instantiate new end-to-end services across heterogeneous domains. Operators/providers can freely and easily change the network configurations, routing rules, and dynamically allocate capacity to match the varying customers' traffic demand [14], and consequently the SP costs can be significantly reduced.

The costs of FM and maintenance can be also reduced by migrating towards SDN. The controllers have complete views of entire network (network elements information, capacities, topologies, traffic load, etc.), which simplifies the network monitoring and fault detection functionality. When a failure happens, the controller/orchestrator can automatically calculate another alternative path and re-route the traffic if available. For repairing faulty devices, the required AON technicians can be shared with the core/aggregation network technicians because both AON and core/aggregation network use the same data plane technology. In addition, because SDN data plane element has no individual C&M, it is vendor-neutral, which simplifies installation and reparation process.

VI. DISCUSSION AND CONCLUSION

The aforementioned migration strategies are proposed from the data plane, topology, and control plane perspective. For a network operator/provider, the selected migration strategy can either consider only one of the aspects or is based on a combination of different aspects. In general, one migration strategy can be integrated with the other strategies, so that the benefits of a single migration method can be added on top of the others. For example, in the migration path focused on the data plane (AON towards WDM-PON or TWDM-PON), SDN controllers can be used for both optical WDM/TWDM-based and electrical packet-based network equipment in order to simplify network C&M.

In a combination of mesh/ring topology and SDN case, the SDN can utilize the advantage of mesh/ring topology to allocate network resource dynamically in a flexible way according to the traffic locality pattern, while the mesh/ring topology can help SDN controller with more options (paths) for FM, traffic engineering, routing, etc.

The migrations towards node consolidation and the mesh/ring topology are quite different in nature. The first one aims at reducing the number of access network nodes, while the second one is making use of the distributed nodes to improve network resiliency and traffic locality feature. However, these two migration trends can still be integrated to a certain extent. Interconnecting MANs and passive components in the field in mesh/ring can improve the network resilience. It is extremely important for the node consolidation scenario, where any single failure may affect a huge number of end-points.

This paper proposes several migration strategies for AON network from data plane, topology, and control plane perspective, respectively, and evaluated these strategies with

respect to the key elements of both CAPEX and OPEX. The proposed migration strategies have both pros and cons depending on their features. They can be adopted either individually or combined. Operators/providers may choose the migration strategies which fit best to both their current network characteristics and future service/network planning.

REFERENCES

- [1] A. Hatt, O. Zetteberg, K. Ahl, D. Bosshart, R. Montagne, V. Chillou, "Press Conference @FTTH Conference", in FTTH Council Europe Conference, Stockholm, Sweden, 2014.
- [2] IEEE Ethernet in the First Mile, IEEE 802.3ah EFM standard, 2005.
- [3] Valerie Chaillou. (2012). Inventory of FTTH/B in Europe. IDATE DigiWorld Institute. Available: http://www.idate.org/en/News/Inventory-of-FTTH-B-in-Europe_765.html
- [4] O. Malik, "In the Netherlands, 1 Gbps Broadband Will Soon Be Everywhere", [online] 2010, Available: <https://gigaom.com/2010/02/19/in-netherlands-1-gbps-broadband-will-soon-be-everywhere/https://gigaom.com/2010/02/19/in-netherlands-1-gbps-broadband-will-soon-be-everywhere/>
- [5] R. Hülsermann, K. Grobe, and D. Breuer, "Cost and Performance Evaluation of WDM-based Access Networks," in Optical Fiber Communication Conference/National Fiber Optic Engineers Conference 2013, OSA Technical Digest (online) (Optical Society of America, 2013), paper NTh3F.4.
- [6] ITU-T G.989 Series Recommendations, "40-Gigabit-Capable Passive Optical Network (NG-PON2)", 2015.
- [7] C. Machuca, S. Krauss, M. Kind, "Migration from GPON to Hybrid PON: Complete Cost Evaluation," in Photonic Networks, 14. 2013 ITG Symposium. Proceedings, May 2013.
- [8] White paper on "Software-Defined Networking: The New Norm for Networks", available: <https://www.opennetworking.org/>
- [9] N. Bitar, "SDN and Potential Applicability to Access Networks," in Optical Fiber Communication Conference, paper Th1G.4, Optical Society of America, 2014.
- [10] C. Bock, C. J. Ferrer, M.C. Parker, S.D. Walker, T. Mendes, V. Marques, V. Jungnickel, K. Habel, D. Levi, "Techno-economics and performance of convergent radio and fibre architectures," in Transparent Optical Networks (ICTON), 2014 16th International Conference on , July 2014.
- [11] B. Skubic and I. Pappa, "Energy Consumption Analysis of Converged Networks: Node Consolidation vs Metro Simplification," in Optical Fiber Communication Conference/National Fiber Optic Engineers Conference 2013, OSA Technical Digest (online) (Optical Society of America, 2013), paper NM2I.5.
- [12] V. Nordell, A. Aurelius, A. Gavler, A. Arvidsson, M. Kihl, "Concurrency and locality of content demand," in Smart Communications in Network Technologies (SaCoNeT), 2013 International Conference on , vol.03, pp.1-5, June 2013.
- [13] FTTH council Europe (16 October 2013), public webinar on: Stokab building, operating and financing the world's largest open passive fibre network. Available: http://www.ftthcouncil.eu/documents/Webinars/2013/Webinar_16October2013.pdf
- [14] A. Rostami, K. Wang, Z. Ghenretensae, P. Ohlen, and B. Skubic, "First Experimental Demonstration of Orchestration of Optical Transport, RAN and Cloud based on SDN," in Optical Fiber Communication Conference Post Deadline Papers, OSA Technical Digest (online) (Optical Society of America, 2015), paper Th5A.7.
- [15] OpenDaylight SDN platform, A Linux Foundation Collaborative Project: <http://www.opendaylight.org>.