

The background of the entire page is a photograph of a modern building's exterior. The facade is composed of vertical, light-colored wood slats. Several windows of various sizes are integrated into the design, some with dark frames. The windows reflect the sky and other buildings, adding depth to the image. The overall aesthetic is clean, natural, and contemporary.

WOOD IN CARBON EFFICIENT CONSTRUCTION

Tools, methods and applications

EDITORS Matti Kuittinen, Alice Ludvig, Gerhard Weiss

WOOD IN CARBON EFFICIENT CONSTRUCTION

Tools, methods and applications



IMPRINT



ClimateCalc CC-000025/FI
HÄMEEN KIRJAPAINO OY



441 209
Printed matter
HÄMEEN KIRJAPAINO OY

EDITORS

Matti Kuittinen, Alice Ludvig, Gerhard Weiss

CHAPTER COORDINATORS

Chapter 1: Matti Kuittinen
Chapter 2: Alice Ludvig
Chapter 3: Leif Gustavsson
Chapter 4: Atsushi Takano
Chapter 5: Tarja Häkkinen
Chapter 6: Annette Hafner
Chapter 7: Tomi Toratti
Chapter 8: Matti Kuittinen
Chapter 9: Alice Ludvig

AUTHORS

Jesper Arfvidsson, Enrico De Angelis, Ambrose Dodoo, Franz Dolezal, Leif Gustavsson, Annette Hafner, Tarja Häkkinen, Matti Kuittinen, Lauri Linkosalmi, Alice Ludvig, Oskar Mair am Tinkhof, Hildegund Mötzl, S. Olof Mundt-Petersen, Stephan Ott, Diego Peñaloza, Francesco Pittau, Roger Sathre, Christina Spitzbart, Atsushi Takano, Tomi Toratti, Tuovi Valtonen, Sirje Vares, Gerhard Weiss, Stefan Winter, Giulia Zanata

LAYOUT AND GRAPHIC DESIGN

Caroline MoineI, Atsushi Takano

FUNDING

This publication was produced with the funding of CEI-Bois.

TRANSLATION

Lingsoft, Finland

PRINTING

Hämeen Kirjapaino Oy, Finland

The carbon emissions from this print job have been offset by purchasing emission reduction credits under WWF Gold Standard certification. ClimateCalc is a tool for calculating the carbon footprint of both the printing company and a specific print job. Hämeen Kirjapaino Oy is the first Finnish printing company to receive the ClimateCalc certificate.

PAPER

Cover: Ensocoat 2S 270g, Stora Enso
Paper: MultiArt Silk 130g, Stora Enso

COPYRIGHT

© 2013 CEI-Bois and the authors. All rights reserved.

ISBN: 978-9-0820-9080-2 (paper)
ISBN: 978-9-0820-9081-9 (e-book)

CONTACT

CEI-Bois
Rue Montoyer 24, BE-1000, Brussels, Belgium
www.cei-bois.org
Email: info@cei-bois.org
Tel. + 32 2 556 2585
Fax: +32 2 287 0875



Wood is probably the most environmentally friendly material that nature has given to man. It is made from carbon, captured from the atmosphere by trees and stored in wood, where the carbon will remain locked for the entire lifespan of the wood. It is not only a magnificent ecological material, it is also a technological material, perhaps even the most innovative and the most extraordinary one at man's disposal.

This book entitled "Wood in Carbon Efficient Construction" provides the analytical tools and examples for calculating the carbon storage and the energy efficiency of whole buildings during their full lifecycles. It also outlines the measurements for inclusion of wooden materials in all relevant production phases as well as in the end-of-life phases. I see this book as a valuable contribution to supporting current efforts in combating climate change by enhancing the use of wood-based products as one of the main construction materials for multi-storey buildings, thereby storing vast amounts of carbon as well as saving CO₂ emissions through substitution of more carbon intensive materials. Furthermore, this book can enable the reaching of European policy initiatives that aim at resource efficiency and a low carbon economy. Tackle climate change: Use more wood!

Gaston Franco

Member of the European Parliament

Chair, Forestry Subgroup of the 'Climate Change, Biodiversity and Sustainable Development' Intergroup of the European Parliament



There is a strong and growing societal and political push to address the environmental performance of the built environment. We appreciate this book for the information it provides on the relevance of transparent life cycle analysis for accounting the advantages of using wooden materials in construction. It gives valuable practical advice to producers, designers, architects and clients alike.

Without actively applying methods and solutions, goals like a zero emission society and the aspirations of Kyoto would remain just another unrealised environmental utopia. It is the construction industry and the public and private building developers who play a major role in all of this because more than one third of the global energy consumption and carbon emissions are attributed to the construction and operation of buildings.

It is my hope that those with the responsibility for CO₂ governance at all levels will find useful information and inspiration in the pages of "Wood in Carbon Efficient Construction".

Matti Mikkola

Chairman, CEI-Bois Board

SVP, Building Solutions, Stora Enso Building and Living



As numerous European Countries are moving towards a "zero carbon" society, the practical means to achieve such a goal are becoming increasingly vital. This initiative also touches the construction sector. Therefore the request for construction materials with no or only low CO₂ emissions during the production and use phases is steadily increasing. In order to meet such demands this book not only develops common evaluation methods, but at the same time manages to show practical solutions that are based on them.

The book is one of the results of the European research project "Wood in Carbon Efficient Construction". Leading experts and researchers from numerous European countries have been collaborating and guarantee its quality and relevance. The project has been initiated by the European initiative BWW Building With Wood under the umbrella of the European Confederation of Woodworking Industries CEI Bois. It is sponsored by the European wood industry in cooperation with national funding organisations within the WoodWisdom-Net framework.

Dr. Erich Wiesner

Chairman of the CEI Bois Building with Wood Steering Group

Chairman of the Association of the Austrian Wood Industries

FOREWORDS



ACKNOWLEDGEMENTS

Financial support for €CO2 research work has been given by several national funding organisations:

- Austria: FFG (Österreichische Forschungsförderungsgesellschaft)
- Finland: TEKES
- Germany: Projektträger Jülich
- Sweden: Vinnova

Private funding has been provided by the following organisations and companies:

- Austrian Chamber of Commerce
- CEI-Bois
- Finnish Wood Research
- Swedish Forest Industries Federation
- FederLegno Arredo
- GreenBuild Ltd.
- Huber & Sohn GmbH & Co.KG

Editing and publishing of this book has been supported by CEI-Bois.

The editors hereby express their thanks for the above mentioned institutions. This book is a result of the collaborative work of many individuals and organisations.

We cannot thank enough all the individual authors for their efforts and their continuing work in making this book a reality. Furthermore we are grateful to all members that took part in our sometimes long and demanding steering committee meetings. In particular, we want to thank Philip Buisseret from CEI-Bois, Tuija Brandt and Matti Mikkola from Stora Enso, Pasi Typpö from GreenBuild, Jan Lagerström, Sara Färlin and Alexander Nyberg from the Swedish Forest Industries Federation, Paolo Lavisci from FederLegno Arredo, Kimmo Järvinen and Jaakko Lehto from Finnish Wood Research and Mikko Viljakainen from Puuinfo for their support. Finally we are deeply indebted to Caroline Moinel for all the intensive work she has invested into the final design and layout of the book.

TABLE OF CONTENTS

1. INTRODUCTION

- 1.1 Scope and goals of this book
- 1.2 The €CO2 research project
- 1.3 Structure of this book

2. BACKGROUND

- 2.1 Introduction: The relevance of carbon footprint assessment for the woodworking and construction sectors
- 2.2 What is life cycle assessment and carbon footprint analysis?
- 2.3 Environmental standards and certification schemes
 - 2.3.1 Standards, norms and organisations for the building sector
 - 2.3.2 Voluntary building certification
- 2.4 Conclusions

3. FUNDAMENTALS

- 3.1 Introduction
- 3.2 Functional units
- 3.3 Substitution
- 3.4 Allocation
- 3.5 Evaluation indicators
- 3.6 System boundary: activities
- 3.7 Production phase
- 3.8 Energy supply
- 3.9 Temporal system boundaries
- 3.10 Spatial system boundaries
- 3.11 Conclusions

4. CARBON FOOTPRINT CALCULATION METHODOLOGY

- 4.1 Introduction
 - 4.1.1 Biogenic carbon emissions
- 4.2 Standards related to carbon footprint
- 4.3 Assessment procedure and assessment tools and their use
- 4.4 Product level
 - 4.4.1 Goal and scope definition
 - 4.4.2 System boundary for wood based products
 - 4.4.3 Data inventory
 - 4.4.4 Allocation of environmental impacts
 - 4.4.5 Interpretation of results
 - 4.4.6 Uncertainties and limitations
- 4.5 Building level
 - 4.5.1 General issues - System boundary condition
 - 4.5.2 Full carbon footprint analysis
 - 4.5.3 Simple system boundary for practical implementation
- 4.6 Conclusions

5. ENVIRONMENTAL ASPECTS FOR RAW MATERIAL SUPPLY AND MANUFACTURING

- 5.1 Introduction
- 5.2 Raw material supply
- 5.3 Sawn timber manufacturing and carbon footprint
- 5.4 Optimisation and development aspects of current manufacturing processes
- 5.5 Conclusions



6. GOOD PRACTICES FOR CARBON EFFICIENT WOOD CONSTRUCTION

6.1 Goal setting and requirements	71
6.2 Designing a low carbon wooden house	72
6.3 Construction	75
6.3.1 Introduction	78
6.3.2 Dominance of construction phase	78
6.3.3 Construction process: Prefabrication	79
6.3.4 Construction: On-site work	79
6.3.5 Transportation	80
6.3.6 Waste management	82
6.3.7 Prefabrication vs. on-site construction	82
6.4 Use and maintenance	85
6.4.1 Introduction	85
6.4.2 Influence of use and maintenance phase	85
6.4.3 Use and operational energy need and related GHG emissions	86
6.4.4 Maintenance and renovations	86
6.4.5 Recommendations	86
6.5 Deconstruction and recycling, end-of-life	89
6.5.1 General	89
6.5.2 Legal framework	91
6.5.3 Building description and life cycle	92
6.5.4 Energy recovery	93
6.5.5 Material recycling	93
6.5.6 Reuse (with low to no modification)	94
6.5.7 Conclusions	94
6.6 Conclusions	95

7. SERVICE LIFE AND MOISTURE SAFETY

7.1 Introduction	100
7.2 Some principles of building physics	100
7.3 A method for including moisture safety in the building process (ByggaF)	102
7.4 Important factors affecting the moisture safety in wooden buildings	104
7.5 Service life considerations for timber structures	105
7.6 Conclusions	106

8. CASE STUDIES

8.1 Introduction	111
8.2 Wälluden as a case study for three new wood building systems, Sweden	112
8.2.1 Consequential approach	116
8.2.2 Attributional approach	121
8.2.3 Final conclusions	123
8.3 4 Holz, Mietchaching, Germany	124
8.4 Austrian buildings	128
8.5 Joensuu Elli, Finland	138
8.6 Tervakukka passive house, Finland	142
8.7 Progetto C.A.S.E, L'Aquila, Italy	146
8.8 Lessons learned	150

9. SUMMARY AND CONCLUSIONS

10. APPENDICES

10.1 Authors	155
10.2 Abbreviations	159
10.3 Picture credits	160
	162
	163



1. Introduction

1 INTRODUCTION

1.1 Scope and goals of this book

The main driver for publishing this book has been to disseminate information about the scientifically proven positive effects on climate of using wood in construction. The findings are the result of a large transnational European research project. The intention has been to document findings that would be of interest to designers, construction companies, LCA professionals, researchers and decision makers.

Since the research work focused on wood construction, other material comparisons are not presented in this book, except for common reference. Because this book has been written by several authors, the text reflects different viewpoints on the same topic.

1.2 The €CO2 research project

Wood in carbon efficient construction ('€CO2') has been a WoodWisdom-Net research project. It started in the end of 2010 and was finished in March 2013.

The original goals of the research project were to:

1. create a holistic understanding of carbon efficiency and primary energy use in the full life-cycle of a building,
2. define the technical potential and obstacles for the use of

- wood in carbon-efficient construction,
3. develop practical solutions for calculating and optimizing the carbon footprint of different wood construction systems, and
4. disseminate the scientific results efficiently to relevant stakeholders, including e.g. authorities, regulation developers and the construction industry.

The project consortium was formed from twenty organisations from five countries: Austria, Finland, Germany, Italy and Sweden. The main supporter of the project was CEI-Bois, and the project was coordinated by Aalto University.

1.3 Structure of this book

In the following chapter, the approaches to Life Cycle Analysis (LCA) measurements and the norms and standards for environmental assessments will be outlined (Chapter 2: "Background"). Subsequently, definitions for the functional indicators and the system boundaries will be discussed (Chapter 3: "Fundamentals"). This will be followed by an introduction of the necessary information and requirements for practical assessments at the building level (Chapter 4: "Carbon footprint calculation methodology"). Later, the life-cycle aspects for the product levels are dealt with (Chapter 5: "Environmental aspects of raw material supply and manufacturing"). Building on those findings, we will demonstrate good practices and their applications for entire buildings (Chapter 6: "Good practices for carbon efficient wood construction") as well as the necessity of moisture safety for carbon efficiency (Chapter 7: "Service life and moisture safety"). The final chapter introduces eight case studies of wood-framed buildings with calculations of both their energy efficiency and carbon efficiency (Chapter 8: "Case Studies"). Finally, the main conclusions from the book will be summarised (Chapter 9: "Summary and conclusions").

THE €CO2 RESEARCH CONSORTIUM

Austria

Austrian Energy Agency
BOKU University of Natural Resources and Applied Sciences
Holzforschung Austria
IBO Austrian Institute for Building and Ecology

Finland

Aalto University
GreenBuild Oy
Micro-Aided Design Oy
Stora Enso
UPM
VTT Technical Research Centre

Germany

Huber & Sohn GmbH
TU München

Italy

Politecnico di Milano

Sweden

Lindbäcks Bygg
Linnaeus University
Lund University
Martinsons
Moelven
SP Technical Research Institute of Sweden





2. Background



14

2.1 Introduction: The relevance of carbon footprint assessment for the woodworking and construction sectors



15

2.2 What is carbon footprint analysis and life cycle assessment?



16

2.3 Environmental standards and certification schemes

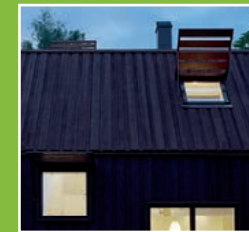

19

2.4 Conclusions

2 BACKGROUND

2.1 Introduction: The relevance of carbon footprint assessment for the woodworking and construction sectors

M. Kuittinen

The Energy Performance of Buildings Directive will become legally binding in the EU in 2020. This is a significant leap for the construction sector. With this in mind, is it relevant to add other criteria to the already heavy burden of environmental requirements? Is carbon footprinting relevant to the construction sector?

A shift in focus to the full lifecycle of buildings

As will be shown in this book, the primary energy use and environmental loads of manufacturing building materials will increase as the operating performance of a building improves. As the environmental requirements for operating buildings are becoming stricter, the next critical step is to increase the carbon efficiency of construction materials and construction methods and to minimize the primary energy use and environmental loads over the entire lifecycle of constructions.

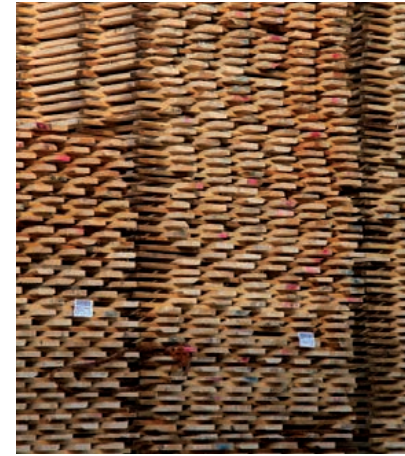

From left to right

F.2.1 Wood harvest, Evo Forest, Finland

F.2.2 Fresh-sawn wood, Honkalahti sawmill, Finland

F.2.3 Mietraching, montage of the facade elements, Germany

Inherent material property

Wood is unique among the major building materials in that it stores significant amounts of carbon from the atmosphere in its biomass. Wood also typically requires less energy for processing, and it can be used for bioenergy at the end of the product's service life. These natural features of wood give environmental advantages to wood-based materials. To achieve this, the carbon and primary energy efficiency should be considered throughout the full production chain of wood-based products, from forestry to end-of-life. To benefit from the inherent properties of wood from sustainable forestry, the use of wood in construction could be increased.

Normative horizon

It is likely that environmental regulations will include the greenhouse gas emissions and primary energy use of construction materials. The EC's Roadmap to a Resource Efficient Europe [1] states that there will be a shift of taxation from labour to environmental impacts. Furthermore, the same roadmap calls for "robust, timely indicators" [2] that would guide decision-makers towards greater resource efficiency. In Finland, for example, national building regulations will include material efficiency parameters beginning in 2016.

Through green public procurement policies are increasing the importance of the environmental performance of products. In the construction sector this has a potentially significant effect, as the built environment is responsible for around 35% of all greenhouse gas emissions and 42% of energy use in Europe. [3]

Actors that are proactively taking steps before the norms are fully implemented, in order to optimize the carbon efficiency of products and services, may have competitive advantages.

Possibilities

By increasing the use of bio-based materials, the carbon storage in the building is usually increased. Total primary energy use during the construction phase decreases when using wood-based materials. From a life cycle perspective, valuable energy resources can be recovered from the wood materials after the service life of the building.

As will be demonstrated through the case studies in Chapter 8, the use of wood seems to be a practical way of decreasing the carbon footprint of buildings. The substitution of other environmentally less beneficial materials, while increasing in the amount of wood

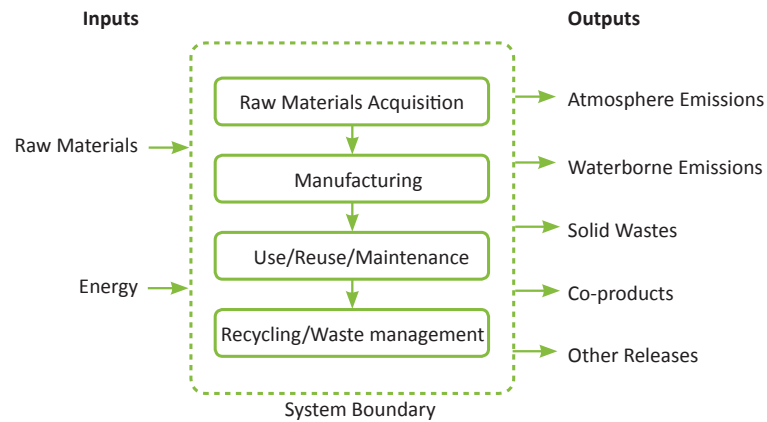

F.2.4

F.2.5



F.2.4 Schematic diagram of life cycle stages, inputs and outputs

F.2.5 Copperhill Mountain Lodge, Sweden

in the building sector, seems to have a significant potential for climate change mitigation.

It seems that the environmental information associated with a product will be one important criterion in its success in public procurement. As Europe has politically expressed its intention to continue leading the climate change mitigation process, the internal markets are likely to be the first test field for environmentally more ambitious products.

This book gives an introduction to utilizing the inherent material properties of wood, preparing for necessary regulatory development, and shifting the focus of environmental building assessment from only the operation energy use towards a life cycle perspective including the embodied energy and greenhouse gas emissions from material production.

2.2 What is life cycle assessment and carbon footprint analysis?

A. Dadoo, L. Gustavsson and R. Sathre

Climate destabilization due to human activity has been identified as one of the greatest challenges facing our society, with major implications for social, biological, and technological systems [1]. In

response, diverse initiatives are being developed and implemented at the local, national, and international levels to limit the amount of greenhouse gases (GHG) in the Earth's atmosphere. These initiatives rely on the assessment, monitoring, reporting and verification of GHG emissions and removals. To ensure that actions are effective at mitigating climate change, the accounting of GHG flows associated with products and materials should be done in a life cycle perspective. In other words, the analysis should consider all inputs (e.g. energy, materials) and outputs (e.g. emissions, waste, co-products) for each stage of processing, from extraction or regeneration through ultimate use, maintenance and disposal.

There are several distinct temporal stages in the life cycle of a building. These include the extraction of raw materials; the processing of raw materials into prepared building materials; the assembly of diverse materials into a ready building; the occupation or use of the building; maintenance of the building; and the demolition of the building and the disposal or re-use of the demolition material. Transport of materials may be involved in all stages.

Life Cycle Assessment (LCA) is an analytical framework for determining the environmental impacts resulting from processes, services and products and may be used to analyse climate impact

of buildings. All life cycle stages (F.2.4) need to be included in a full LCA.

A formal LCA analysis includes four phases [2]. Goal and scope definition describes the purpose of the study, the system boundaries of the analysis, and the functional unit used for assessment and comparison. Inventory assessment quantifies the inputs and outputs of mass and energy attributable to processes occurring within the system boundaries. Impact assessment characterizes the effects of these inputs and outputs considering resource depletion, human health, ecosystem quality, and climate change. Interpretation of the inventory and impact assessment results seeks to identify significant conclusions, recommendations and implications for decision-making.

Carbon footprint analysis is a related discipline focused exclusively on Global Warming Potential (GWP), an LCA impact category measured by the climate change potential of GHG emissions in units of CO₂ equivalent.

Estimation of the life cycle environmental impacts associated with a particular product or process is termed an "attributional" LCA (ALCA), based on measures of all its associated inputs and outputs. An ALCA provides information about the impacts of processes to produce, consume and dispose of an average single unit of product,

but does not include induced effects from changes in outputs such as shifts in production and emissions from other products that are displaced by the product being assessed. Estimation of the change in overall impacts associated with the introduction of a system element is termed a “consequential” LCA (CLCA). CLCAs provide information about the consequences of changes in the level of production and use of a product and aim to include all direct and indirect effects that may be associated with changes in output [3]. The indirect effects are driven by market forces. For example a change in consumption of construction lumber would influence the demand for and production of non-wood building materials. The system boundaries of CLCAs are broadly expanded and may include producers and users of wood plus producers and users of direct wood substitutes such as fossil fuels and concrete.

To produce LCA results that contribute to robust policy decisions, LCA practitioners endeavour to quantify all relevant environmental benefits and impacts of the systems under study. LCA is a meta-analysis that consolidates and evaluates information about a system’s behaviour. Robust uncertainty assessment can assist analysts in identifying when a policy or decision is likely to lead to the desired environmental outcome, as well as the information that is needed to improve LCA quality. Uncertainty in LCA can be evaluated from parameter, model, and scenario considerations [4]. Parameter uncertainty is related to data quality, incorporating knowledge of central tendencies and ranges of key variables. Model uncertainty considers the accuracy of mathematical models in simulating real-world system behaviour. Scenario uncertainty reflects how actual behaviour may differ from the normative assumptions used in the analysis.

LCA is a methodology that not only allows the quantification of existing environmental profiles, but also the identification of improvement alternatives in order to reduce future environmental impacts. A useful LCA will provide a breakdown of the sources and magnitudes of impacts from different flows within the life cycle, allowing identification of “hotspots” or the most significant contributors to the environmental profile of a product. This will allow decision-makers to focus resources on developing process improvements to reduce the impact of hotspots, thus increasing the effectiveness of mitigation efforts.

Improving climate performance in the built environment involves material and energy flows in different economic sectors including forestry, manufacturing, construction, energy, and waste management. Integration of resource flows within and between these sectors can improve the overall life cycle environmental performance of the built environment, though accurate analysis across this broad range of natural and technological processes is complex [5]. Robust LCA can provide a better understanding of the relative impacts caused by different products over their entire life cycles, which is needed to design effective climate change mitigation solutions.

2.3 Environmental standards and certification schemes

2.3.1 Standards, norms and organisations for the building sector

A.Ludvig, G.Weiss

The sustainable development of the building sector is largely governed through standards. They are embedded in a semi-public regulatory framework – which includes a number of standardization processes. We will focus here on the standards that have been developed by committees or boards. Most relevant normative technical standards for European wood construction are authored by the European Committee for Standardization (CEN) and the International Organization for Standardization (ISO).

The Regulation of Construction Products: Within the European Union the issue of construction is currently under coordination of Directorate General Enterprise and Industry (DG ENTR). The objectives of DG ENTR’s work range from strengthening Europe’s industrial base to promoting the transition to a low-carbon economy. Thus, many other policy fields that are actually coordinated by other DGs influence the development of the whole construction sector. These other DGs are responsible for regional policy, energy, environment, climate, competition, research and external relations.

DG ENTR has prepared the Construction Products Regulation (EU) No 305/2011 (European Parliament and European Council) from March 9, 2011, which lays down “harmonised conditions” for

F.2.6 Spruce sapling



the marketing of construction products and shall modernise the former so-called Construction Products Directive (89/106/EEC). By being a regulation, it becomes direct law. Its objective is not to define the safety of construction products, but to ensure that “reliable information is presented in relation to their performance”. This is achieved, mainly, through standards.

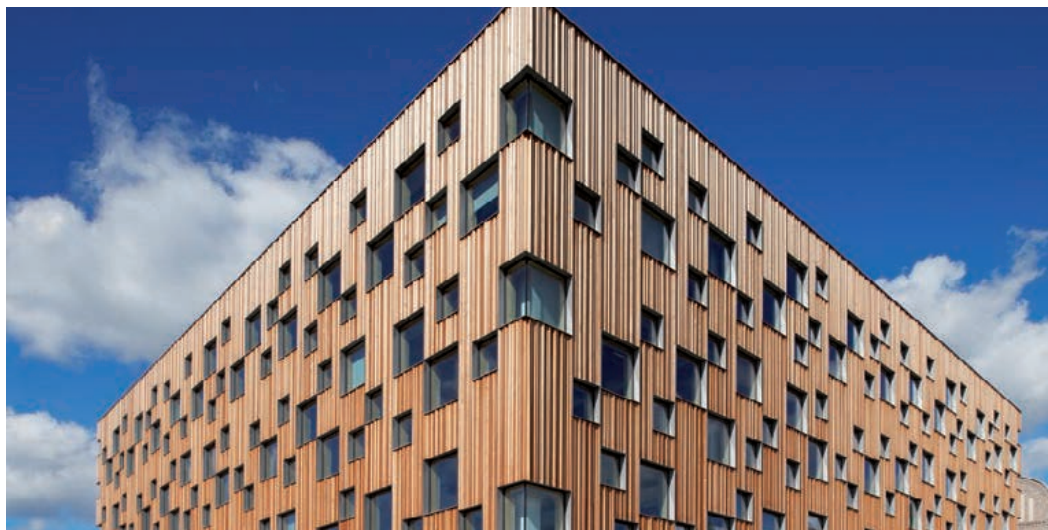

F.2.7
F.2.8

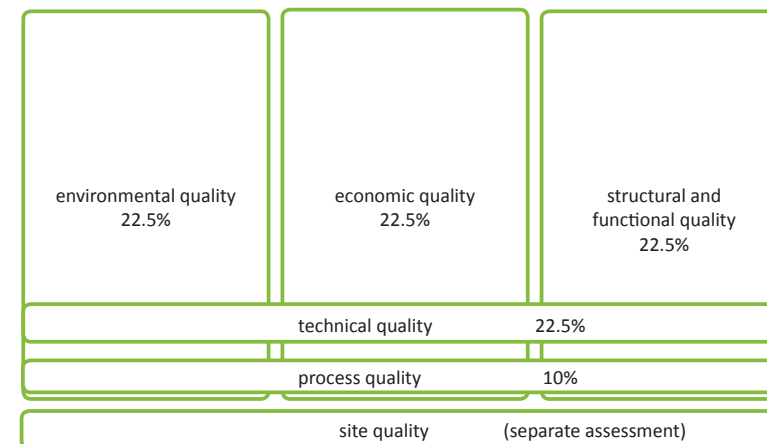

F.2.7 Umeå University School of Architecture

F.2.8 Different qualities included in the sustainability certification system of DGNB/BNB

The Standards Regime

A standard defines guidelines, rules and norms for the performance and judging of products. Within the EU and EFTA countries, the mandate for developing standards has been given to the European Committee for Standardization (CEN), where the secretary hands the task over to the relevant Technical Committee (TC) to carry out the details. CEN is composed of the national standardization institutes from all EFTA countries and currently holds around 400 TCs together with about 100 working groups. TCs are formed of technical experts, very often from the relevant industries and companies who are members in one of the national standardization institutes. CENs TCs dealing with wood in construction are the Technical Committee on the Sustainability of Construction Works (CEN/TC/350), CEN/TC 124 on Timber Structures, and CEN/TC 175 on the Structure of Round and Sawn Timber.

The **Standing Committee on Construction (SCC)** was set up per the Construction Products Directive (see above) to examine any questions posed by the implementation and practical application of the Construction Products Directive. Each Member State appoints two representatives who may be accompanied by experts. The SCC acts foremost in an advisory function vis-à-vis the European Commission. With the new regulation, also technical assessment

bodies (TABs) as well as national country contact points (provided by the national administrations) shall administer the implementation procedures.

Numerous relevant policy fields

Another DG involved is DG ENERGY which has developed the Energy Performance of Buildings Directive 2010/31/EU (EPBD), the EUs main legislative instrument to reduce the energy consumption of buildings. Please note that in contrast to a regulation (see above), a directive is not directly binding but has to be converted into national law by EU member states. EPBD asks all member states to define minimum requirements for the energy performance of new and existing buildings, to ensure the certification of their energy performance and requires the regular inspection of boilers and air conditioning systems in buildings.

Furthermore, DG ENVIRONMENT is promoting **Green Public Procurement (GPP)** targeting the public sector consumption of EU member states to reduce environmental impact. GPP is laid down in the voluntary communication "Public procurement for a better environment" (COM (2008) 400), whereby 50% of all public tendering procedures for goods, services and work should be green

by 2011. It should be noted that construction has the third-largest share in GPP affected national budgets, after transport and office IT.

In 2011, DG CLIMA prepared the "**Roadmap for moving to a competitive low-carbon economy in 2050**", which sets out a plan to meet the long-term target of reducing domestic emissions to 80-95% by 2050. A "roadmap" is a communication to all institutions and bodies within the EU (Council, European Parliament, European Economic and Social Committee, and Committee of the Regions) as well as all national parliaments. It shows how the sectors responsible for Europe's emissions – power generation, industry, transport, buildings and construction, and agriculture – could make the transition to a low-carbon economy over the coming decades. Another goal is to develop specific roadmaps in cooperation with these sectors.

The International Level

At the international level, all member institutions that form part of CEN are also members in the **International Organization for Standardization (ISO)**. Since the "Vienna Agreement" in 1991, technical cooperation by correspondence, mutual representation and coordination at meetings is ensured between CEN and ISO. The Vienna Agreement also declares the adoption of the same



text, as both an ISO standard and a European standard. Like CEN, ISO is composed of the national standards institutions from 162 countries, with a central secretariat in Geneva, Switzerland. ISO has around 300 TCs around the world, whereby ISO/TC/165 deals with Timber structures and ISO/TC/218 with wood building systems.

Environmental standards of relevance for the building sector

The above-mentioned Technical Committees (TCs) have developed a wide range of technical norms (standards) in the field of construction, building, life-cycle assessment and environment. [1] In the following we will explore some of the most relevant standards and divide them across two categories: (A) Building and sustainable construction, (B) LCA and Carbon Efficiency; each for both levels: the international (ISO) and the European (CEN).

A. Sustainable Construction: Most relevant here are two norms: ISO 15391:2008 Sustainability in building construction: General principles together with ISO 21930: 2007 Environmental declaration of building products. In the standards family of “Sustainability in construction works” at the EU-level we find the corresponding standards EN 15643: 2010-11 (1,2,3): assessment of buildings, EN 15978 assessment of environmental performance and EN 15804 comparable environmental information-Environmental Product Declarations.

B. Carbon Efficiency and LCA: At the international level, there currently exists only one draft standard that deals with the carbon footprint of products, in general and regardless of product types: ISO 14067 Carbon footprint of products – requirements and guidelines for quantification and communication. Also very general at the moment within the ISO-140XX family of standards “Environmental labels, declarations and environmental management”, there are ISO 14040 Life Cycle Assessment – principles and framework, and ISO 14044 Life Cycle Assessment – requirements and guidelines. At the EU level, there is currently an ongoing initiative for harmonizing methodologies (ICLD) within the European Commission. These should be based on the above-mentioned ISO-standards.

F.2.9

There are currently two ways of assessing the carbon footprint of buildings: (1) Either using EN 15978 for whole buildings and EN 15804 for products in general (however, these do not declare wood), or (2) use the general approach to carbon footprint assessment (ISO 14067), which equally does not take into account the specific attributes of wooden products in a whole life cycle. All in all, the current normative framework is still under development for reflecting the specific advantages of wood in construction when it comes to environmental performance in general and carbon efficiency in particular.

In addition to the normative framework of CEN and ISO there exist a number of standards and regulations that are voluntary agreements between firms and enterprises. The following subsection will outline those with reference to the building sector.

2.3.2 Voluntary building certification

A. Hafner

Voluntary certification systems measure sustainability with various indicators for ecologic, economic and social criteria. Each criterion is then filled with benchmarks and performance indicators.

In Europe there are various voluntary sustainability certification systems to assess buildings in Europe. These certification systems are seen as an instrument to measure sustainability and at the same time to promote it to the public. Mostly high-ranking buildings and showcases are getting certified. Already during the planning process, the system can mark influential parameters where the building can be optimized for sustainability.

The existing systems, such as LEED, Breeam, and HQE [1], measure sustainability through performance indicators in form of a checklist. The conformity to different stages of requirements results in a certain level of ranks. The assessment systems were enlarged in 2008 by the German system of DGNB/BNB [2]. As a second-generation certification system it included quantified life-cycle assessments and life cycle costing as requirements. All objectives of the criteria are shown transparently. The European project Openhouse [3], which focuses on the realisation of a harmonized

European building assessment system, uses the same systematic: system boundaries and indicators for life cycle analysis calculations as second generation systems like DGNB/BNB. As LCA calculations are included in the second-generation system, the methodology and proceedings will be discussed concerning LCA issues.

With respect to sustainability, the approach in the second-generation tools is based on the three dimensions of sustainability: ecological, economical and sociocultural factors. Crosscutting qualities with regard to the building also take into account the technical quality of building and the process quality.

The scheme is in compliance with the European standard EN 15643-1 – Sustainability of construction works [4]. Each dimension itself is then subdivided into criteria which are evaluated through different indicators with appropriate benchmarks. Therefore each LCA calculation for a building to be certified needs to be assessed against benchmarks. The ecological indicators weigh more than one-fifth of the whole assessment.

For the assessment a set of rules is necessary, as well as a definition of benchmarks for each indicator related to the ecological quality of the building. The framework consists of the following:

- System boundary is the building without outside facilities. For the use phase, energy consumption is considered according to obligatory energy calculations. The functional unit is m² of net gross floor area. This functional unit is not the same as the heated floor area needed for energy calculations, so cautious calculations are necessary.
- Calculations are done for a reference service life (RSL) of 50 years and the whole life cycle from material input until end-of-life stage.
- The complete construction and technical equipment is to be included in the calculations. Modules A4 and A5 are not yet included in the calculations due to a lack of reliable data.
- Calculations of environmental impacts are done for primary energy nonrenewable, primary energy renewable, global warming potential, ozone depletion potential, acidification

potential, photochemical ozone creation potential and eutrophication potential.

- Calculated stages are: erection of building, utilization phase, and end-of-life.
- For maintenance, there is a list on the estimated service life (ESL) of various building materials and components that must be applied. ESL shows the expected service life of the materials and components. As end of life scenario only a small number of defined scenarios are to be used.
- Wood specific issues are: prove of the amount of certified wood (FSC, PEFC); and in connection with the use of hazardous substances, the absence of wood preservatives.

Different parts of the LCA calculations are under constant discussion – such as the list on the estimated service life, the ecological database, the calculation period and the relatively low impact of energy efficiency. But such lists establish the chance to compare building structures, materials and energy standards in a transparent way. The topic of resource efficiency is not yet tackled in depth. The advantages of using wood for certification systems can only be seen indirectly through a lower GHG, the part of PE from renewable sources, and the factor of PE-renewable to PE-non-renewable.

2.4 Conclusions

The aim of this chapter is to comprehensively outline the background for a Life Cycle Analysis of wood in the construction of buildings. It first argues that the potential for using wooden materials must mitigate climate change in one of the largest CO₂-emitting sectors worldwide, namely the construction sector (2.1). Second, it explains the possible approaches towards concretely assessing and measuring the carbon implications of wood throughout the full life cycle of buildings, either by attributional or consequential LCA (2.2). Third, it describes the environmental policies, norms and standards that currently determine environmental assessments and certifications in the construction sector. The respective sections deal with the official national and international policies and norms stemming from committees and boards (2.3.1) as well as the state-of-the-art of voluntary building standards (2.3.2).

We conclude that the advantages and potentials of wood for mitigating climate change are convincing and that scientifically proven methods and measures for assessing it already exist. Nevertheless, the current normative policy framework in these matters is still under development so that it can adequately reflect and promote the specific advantages of wood.



F.2.10

F.2.9 Villa Nuotta, Kerimäki, Finland

F.2.10 Friisilä housing area, Espoo, Finland



MIKKPOLI

M

From left to right

F.2.11 Mikpoli, Mikkeli, Finland

F.2.12 Villa Karlsson, Tidö-Lindö, Sweden



2.1 Introduction: The relevance of carbon footprint assessment for the woodworking and construction sectors

- [1] European Commission, 2011. Roadmap to a resource efficient Europe, p.11. [pdf] Available at: <http://ec.europa.eu/environment/resource_efficiency/pdf/com2011_571.pdf> [Accessed 12 June 2013].
- [2] European Commission, 2011. Roadmap to a resource efficient Europe, p.21. [pdf] Available at: <http://ec.europa.eu/environment/resource_efficiency/pdf/com2011_571.pdf> [Accessed 12 June 2013].
- [3] European Commission, 2007. Action plan for sustainable construction. [pdf] Available at: <http://ec.europa.eu/enterprise/policies/innovation/policy/lead-market-initiative/files/action_plan_construction_en.pdf> [Accessed 12 June 2013].

2.2 What is carbon footprint and life cycle assessment?

- [1] IPCC (Intergovernmental Panel on Climate Change). 2007. Climate Change 2007: Working Group I: The Physical Science Basis. Web-accessed at <http://www.ipcc.ch/>
- [2] ISO (International Organization for Standardization). 2006. ISO 14044: 2006 Environmental Management: Life Cycle Assessment—Requirements and Guidelines. ISO, Geneva.
- [3] Brander M, Tipper R, Hutchison C, Davis G. 2009. Consequential and Attributional Approaches to LCA: A Guide to Policy Makers with Specific Reference to Greenhouse Gas LCA of Biofuels. Technical Paper TP-090403-A; Econometrica.
- [4] Huijbregts MAJ, Gilijamse W, Ragas AMJ, Reijnders L. 2003. Evaluating uncertainty in environmental life-cycle assessment: A case study comparing two insulation options for a Dutch

REFERENCES

one-family dwelling. Environmental Science & Technology 37(11): 2600-8.

- [5] Gustavsson L and Sathre R., 2011. Energy and CO₂ analysis of wood substitution in construction. Climatic Change 105(12): 129-153.

2.3 Environmental standards and certification schemes

2.3.1 Standards, norms and organisations for the building sector

- [1] For the building sector see a small selection in König, H., Kohler, N., Lützkendorf J., Kreißig T., 2009. Lebenszyklusanalyse in der Gebäudeplanung. Munich: Delta, we refer here to page 97.

2.3.2 Voluntary building certification

- [1] Leed: World Green Building Council, Ontario CDN: <<http://www.worldgbc.org/>> [Accessed 22 October 2012] Breeam: Building Research Establishment (BRE), Watford GB: <<http://www.breeam.org>> [Accessed 22 October 2012] HQE: Association HQE, Paris: <<http://assohqe.org/hqe/>> [Accessed 22 October 2012].
- [2] DGNB: Deutsche Gesellschaft für Nachhaltiges Bauen e.V., Stuttgart: <<http://www.dgnb.de/>> [Accessed 22 October 2012] BNB Bewertungssystem Nachhaltiges Bauen für Bundesgebäude: Bundesministerium für Verkehr, Stadt und Landentwicklung (BMVBS). Berlin: <<http://www.nachhaltigesbauen.de/bewertungssystem-nachhaltiges-bauen-fuer-bundesgebäude-bnb.html>> [Accessed 22 October 2012].
- [3] Acciona Infraestructuras S. A. eds. Openhouse. <<http://www.openhouse-fp7.eu/>> [Accessed 22 October 2012].
- [4] EN 15643-1:2010. Sustainability of construction works – Sustainability assessment of buildings – Part 1: General framework.



3. Fundamentals: Greenhouse gas and primary energy balances over a building life cycle

FUNDAMENTALS: GREENHOUSE GAS AND PRIMARY ENERGY BALANCES OVER A BUILDING LIFE CYCLE

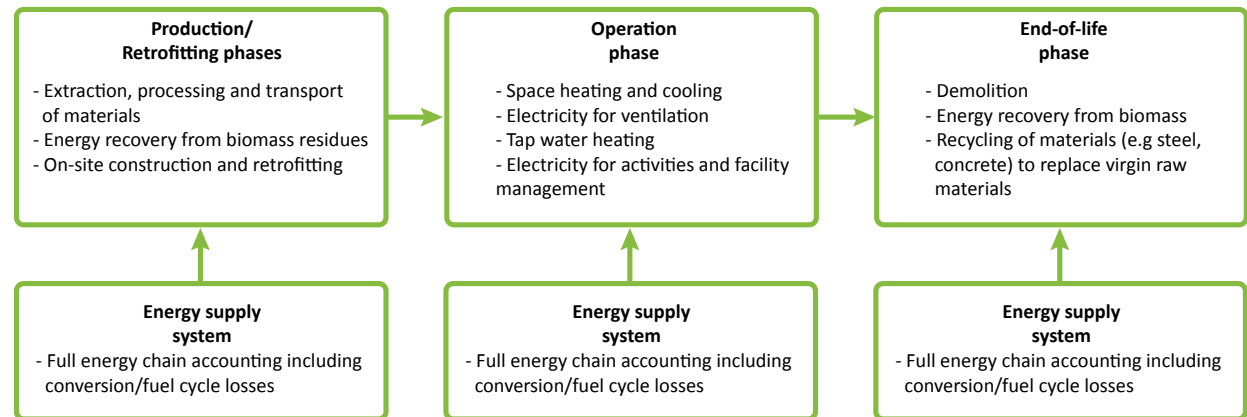

F.3.1 Schematic diagram of a building's primary energy use and GHG emissions from a life cycle perspective

L. Gustavsson, A. Dodoo, H. Mötzl and R. Sathre

3.1 Introduction

A comprehensive analysis of primary energy and greenhouse gas balances (GHG) of buildings should include all life-cycle phases and their interaction with energy supply systems (F.3.1). Major methodological issues regarding the estimation of primary energy and greenhouse gas (GHG) balances over a building life cycle include functional units, allocation procedures, evaluation indicators, and system boundaries in terms of activities, time, and place. The draft technical specification on carbon footprint analysis (ISO 14067-1) states that a scientific approach should be used in quantifying the carbon footprint of products, focusing on relevance, completeness, consistency, accuracy, and transparency for the complete life cycle of the product [1]. In general, existing standards provide broad guidelines regarding analytical approaches, but more specific methods are required for practical application. Therefore, this chapter will present the fundamental definitions of these methodological issues

3.2 Functional units

A functional unit is a measure of the required properties of the studied system, providing a reference to which input and output flows can be related. Defining a functional unit allows the comparative analysis of different buildings or building materials [2]. Energy use or GHG emissions per unit of mass or volume of material is inadequate as a functional unit because equal masses or volumes of different materials do not fulfil the same function [3]. Standard EN 15978 gives rules for the functional equivalent for buildings. According to the standard, the functional equivalent of a building (or an assembled system) shall include the following aspects: building type, relevant functional and technical requirements, pattern of use, and required service life.

Different structural and material options can be compared for different building components such as wall structures and roof structures. Performance can be compared on the basis of the services provided by the building rather than the building itself. For example, if the primary service provided by a building is protection against climatic elements, a comparison can be made on the basis of m^2 or m^3 of climate-controlled floor area or interior space.

3.3 Substitution

Analysis of the primary energy and GHG implications when wood substitutes non-wood products is a complex issue. Wood product substitution raises two important questions: what would happen without the substitution, and how will the substitution system perform. In principle, marginal changes will occur in both the reference system (the non-wood product system) and the substitution system (the wood product system). These changes need to be analysed comprehensively. A consequential LCA approach is suitable to characterize the effect of changes within the life cycle of a product or system. All direct and indirect effects that may be associated with changes in output should be considered.

3.4 Allocation

Issues of allocation of life-cycle impacts or benefits may arise due to co-products and residues from forestry and wood-processing activities. The choice of allocation procedure can have a significant effect on the results of a comparative analysis of wood and non-wood products [4]. Allocation is the process of attributing impacts or benefits to a particular part of a process that results in multiple outputs. This is particularly important for wood materials, because multiple co-products are produced from the same raw

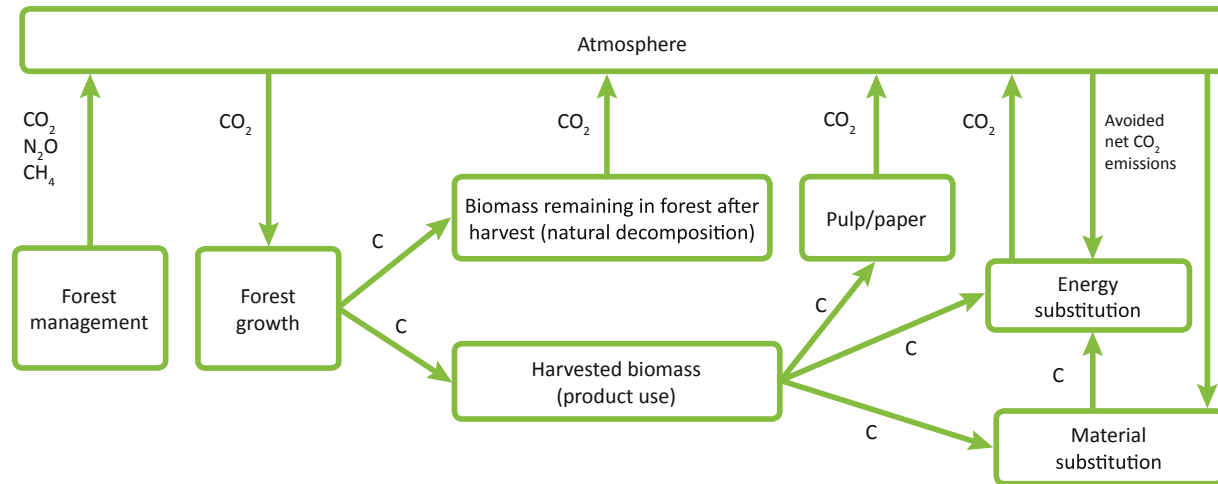

F.3.2 Schematic diagram of GHG flows and carbon stocks tracked on an annual basis for lifecycle forest products substituting non-forest products. (Source: Sathre and Gustavsson [24])

material, and wood products themselves can be used as biofuel at the end of their service life as a material product. Allocation is a subjective procedure and depends in part on the perspectives and values of the analyst. The ISO LCA guidelines state that allocation procedures must be clearly described, and the sums of inputs and outputs must be the same for the systems regardless of allocation method [5]. If possible, the functional unit should be selected to avoid allocation. Allocation can often be avoided, e.g. by system expansion by adding additional functions to the functional unit so the systems compared have identical functions.

3.5 Evaluation indicators

Important evaluation indicators include net GHG emissions, net primary energy use, woody biomass consumption, and land use efficiency. A fundamental objective of the €CO₂ project is carbon-efficient buildings, thus carbon emissions per functional unit is an important indicator to measure. More specifically, all relevant greenhouse gases (e.g. CO₂, CH₄, N₂O) should be included if their climate impact is significant. Because wood construction requires forest activities that removes CO₂ from the atmosphere through photosynthesis, sequestered CO₂ is an important issue in the LCA of wooden products. The current draft for product category rules for wood-based products (prEN 16485) presents

that GHG emissions should be measured on a net basis including all flows to the atmosphere over a given time horizon [6]. All GHG removals from the atmosphere arising from the life cycle of a product should be included. A system with lower net carbon equivalent emissions at the end of the time period is considered to be more climate-friendly than a system with higher net emissions. This approach, however, does not fully take into account the atmospheric dynamics of GHGs or albedo changes.

Forest GHG flows and dynamics

The life cycle of a wood product begins with the germination of the tree seed, and continues through the growth and harvest of the tree and the manufacture and use of the resulting product (F.3.2). The carbon flux is time-dependent, as the trees grow and accumulate carbon in their tissues, and it affects the soil carbon content due to root development of the plants and their falling detritus. This requires an analytical approach that captures the time dynamics of the plant growth, with explicit consideration of the temporal scope of the analysis [7]. The carbon stock is tracked through the life of the tree and through the life cycle of the wood product until the carbon is eventually released again into the atmosphere through combustion or decay.

Forest carbon flows have different dynamics when analysed at the tree or stand level, or at the landscape level. When a tree or stand is harvested, the carbon in a living biomass is transferred to other carbon pools such as wood products, forest floor litter and the atmosphere. The carbon can be tracked over time, while the carbon stock in the living biomass re-accumulates as the forest regrows. Depending on biogeographical factors, the rotation period of forest stands ranges from decades to over a century. Following the harvest of the forest stand (assuming no change in land use), the regeneration of the trees initiates another cycle of carbon accumulation in a living biomass. At the landscape level, the dynamic patterns of the individual trees or stands are averaged over time as carbon flows into and out of various carbon pools associated with trees at different stages of development. Thus, at the landscape level the total carbon stock in the living biomass tends to remain fairly stable over time, as the harvest of some trees during a given time period is compensated by other trees growing during the same period. If forests are managed appropriately, the average carbon stock in forest biomass can increase over time [8]. Biomass production in European forests is expected to increase over time, as in Sweden (F.3.4) [9].

Simultaneously, the flow of harvested biomass out of the forest gives continually increasing carbon benefits due to fuel and



F.3.3 Pine forest, Noormarkku, Finland

material substitution. If instead the trees are not harvested, the forest biomass would eventually reach a dynamic equilibrium, with the amount of carbon taken up by new growth balanced by the carbon released by respiration in living trees and decay of dead trees, but without the biomass flows available for substitution. Carbon storage in forest soils changes at a slower rate, thus moderating the changes in total forest ecosystem carbon stock [10]. Managing forests so as to maintain or increase forest carbon stocks, while simultaneously producing a yield of usable biomass, is increasingly seen as a forest management strategy with a large sustained climate mitigation benefit over the long term.

Conventional carbon balance accounting does not consider albedo, which is a measure of the reflectivity of a surface. Changes in land surface albedo, e.g. between forested and harvested land, can significantly change the balance of solar radiation and hence radiative forcing, particularly in boreal forest regions [11, 12]. Typically, harvested land has a higher albedo than forested land, giving a cooling effect.

The use of a climate impact indicator that takes into consideration the timing of emissions and sinks and the albedo changes would give more accurate results but would increase the complexity of the analyses. A suitable indicator might be cumulative radiative

forcing, which measures the total amount of energy added to the earth system and is a proxy for surface temperature change and hence disruption to physical, ecological and social systems.

Primary energy use

Another important evaluation indicator is net primary energy use per functional unit. Primary energy use, distinct from final energy use, includes all energy inputs along the full chain from raw materials to delivered energy services. Primary energy used for all life cycle processes and activities should be considered. Energy that is made available for external use (for example, from biomass residues generated during the building life cycle) should be included in the analysis. This may be calculated and shown separately. It is useful to distinguish between non-renewable fossil primary energy use and renewable energy use. Fossil primary energy use should be broken down by source, e.g. coal, oil, and fossil gas.

Woody biomass consumption

Because forest biomass is a limited resource, another important indicator is consumption of woody biomass per functional unit. Woody biomass consumption can be measured, e.g., per m³ of wood product or per m³ of roundwood, as appropriate. Land-use

efficiency is also an important indicator to evaluate resource-efficient construction solutions, and can be measured in units of hectares of forest land needed per functional unit. This indicator accounts for differing forest productivity due to different geographic regions or forest management intensity.

Additional indicators

If data availability allows, additional indicators in the form of typical LCA categories may be measured, including indicators of environmental impacts, resource inputs, and waste and output flows. The environmental impact categories include ozone depletion, acidification, eutrophication, photochemical oxidants, and abiotic resource depletion. The resource inputs categories include inputs of renewable primary energy resources, non-renewable primary energy resources, secondary materials and fuels, and fresh water. Waste categories include hazardous waste, non-hazardous waste, and radioactive waste.

3.6 System boundaries: activities

System boundaries related to activities include building production, operation, end-of-life, and all related energy and material processes required during the building life cycle. All these phases should

normally be considered. According to the ISO standards, “the deletion of life cycle stages, processes, inputs or outputs is only permitted if it does not significantly change the overall conclusions of the study. Any decisions to omit lifecycle stages, processes, inputs or outputs shall be clearly stated, and the reasons and implications for their omission shall be explained” [1].

3.7 Production phase

Raw materials for building production are extracted from their natural state (e.g. by mining of minerals) or are cultivated (e.g. timber production in managed forests). The materials may then go through one or several stages of processing and re-processing. A “cradle to gate” analysis of material production includes the acquisition of raw materials, transport, and processing into usable products. Different physical processes can be used to produce the same material, each process with unique requirements and effects on the environment. The efficiency of industrial technologies has generally improved over time, resulting in differences in energy requirements and emissions between materials processed by state-of-the-art technologies and those made in older factories. Variation is also seen geographically, as technological innovations diffuse across countries and regions. Data on industrial energy use can also vary depending on the methodology used to obtain the data. System boundaries of an energy analysis can range from a restrictive analysis of direct energy and material flows of a particular process, to an expansive analysis including energy and material flows of entire industrial chains and society as a whole. Data may be direct measurements of a particular machine or factory, or may be aggregated for an entire industrial sector. The type of end-use energy varies, and could include electricity, biofuels, and various types of fossil fuels.

Efforts to collect, process, and make available improved data needed for accurate analysis of building construction are important. Greater attention should be focused on defining average and marginal values and the range of variability of key input data needed to analyse carbon and energy flows of building construction. In addition, the consideration or exclusion of planned changes in the generation of power and heat, can significantly affect the assessment results [13].

A part of the energy use in the production phase of buildings appears to be indirect and is not recognized when applying the conventional bottom-up LCA methodology [14]. This is due to truncation error in bottom-up analysis, in which direct processes that are central to the object of analysis are studied in great detail, but indirect, secondary processes are analysed in less detail or are ignored completely, e.g. embodied energy in the infrastructure used for the production, distribution and end-use of electricity and heat. The potential underestimation of GHG effects due to hidden, indirect energy use may be significant.

Cement process emissions including calcination and carbonation can be a significant part of the GHG emissions of cement products and should be included in the analysis [15]. Studies of conventional construction have concluded that on-site construction activities use only a minor part of the total life cycle energy use of a building [16].

Operation phase and service life

In the building operation phase, the energy use of the building should be taken into account, including space heating, ventilation, cooling and tap water heating as well as the primary energy efficiency of supply systems, lifespan and maintenance of the building. The operation phase generally contributes the greatest share of the life cycle energy use and GHG emissions of a conventional building. However, as the energy use for operation decreases through efficiency improvements, it becomes relatively more important to consider the other phases of a building’s life cycle [17, 18].

Comparing and optimizing building system components with respect to life cycle primary energy use and GHG emissions will require taking into account the maintenance requirements (e.g. periodic painting of exposed surfaces) and life span of materials, which may vary significantly for different materials.

End-of-life phase

The final stage in the life cycle of a building is the demolition or disassembly of the building followed by the reuse, recycling or disposal of the materials. Post-use wood products can be

F.3.4

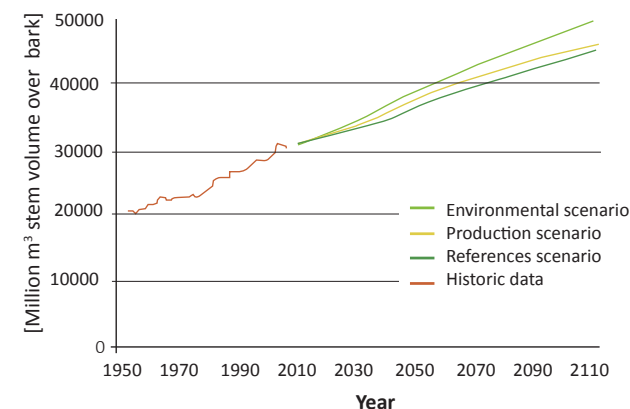

F.3.5

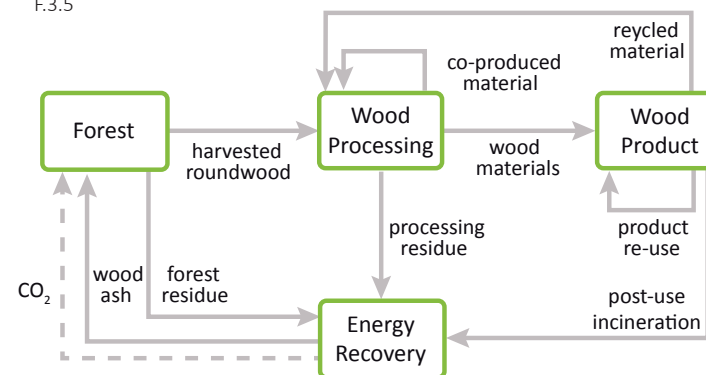

F.3.4 Historic and projected future standing stem volume on productive forest land in Sweden. (Source: Swedish Forest Agency [25])

F.3.5 Schematic diagram of system-wide integrated material flows of wood products

managed as part of an integrated flow of material and energy within and between the forestry, construction, energy, industry and waste management sectors (F.3.5). Buildings may be designed and constructed to facilitate effective management of materials after their service life. Design and construction of buildings for effective post-use material recovery may require that buildings are designed for disassembly or deconstruction. This approach to construction presents greater possibilities for integrating more effective end-of-life options for materials because consideration is given to end-of-life material management in the early stages of building design and construction. ISO draft standards also state that “all the GHG emissions and removals arising from the end-of-life stage of a product shall be included in a [carbon footprint] study” [1]. In cases where material reuse of recovered wood is not practical, three main end-of-life options exist: landfilling, combustion with or without recovery of energy. Landfilling of wood is not legal in the EU. Burning the wood without energy recovery is wasting resources. In contrast, burning with energy recovery may give significant energy and climate benefits, as the use of other energy resources as fossil energy can be reduced. The energy and climate performance of non-wood materials such as steel or concrete may also be significantly affected by post-use management [15].

3.8 Energy supply

Primary energy required for providing the different types of end-use energy, and the resulting GHG emissions, can be determined through consideration of fuel cycle, conversion, and distribution losses. The assumed production of electricity used for material processing and building operation can be significant. Various types of electrical production systems exist, with significant variations in associated primary energy use and GHG emissions. Values for average or marginal primary energy efficiency and GHG emissions from electricity production could be used in an analysis. However, average data would not adequately capture the effect of changes to the system brought about by changes in the building construction. This is because changes in electricity supply do not occur at the average level, but at the marginal level [19]. An electricity grid is generally powered by a variety of sources of differing capacities, and some of these sources are

brought on-line and off-line depending on changes in demand over time scales of hours, weeks and years; these are defined as marginal sources. Depending on the magnitude of the changes that occurs, i.e. whether the changes occur on the level of an individual building construction or a society-wide transition toward a bio-based economy, an analysis of the dynamics of the electricity production system might be needed to understand marginal changes that may occur at differing scales. Furthermore, electrical supply systems continue to evolve over time. In the years and decades to come, the marginal electricity production will be affected by the evolution and development of the energy system as a whole.

Globally, our society is heavily dependent on fossil fuels, which supply more than 81% of the world’s primary energy. Specifically, oil, coal and fossil gas provide 33%, 27% and 21% of global primary energy supply, respectively [20]. We face a major challenge to transition from a society driven mainly by stored solar energy, in the form of fossil fuels, to one driven by active solar energy exploited at a sustainable rate. Scenarios by IPCC show a significant global dependency on fossil energy in the long term [21].

3.9 Temporal system boundaries

Temporal system boundaries include the service life of the structural system and façade materials, as well as aspects of the wood product life cycle such as the dynamics of forest growth including regeneration and carbon sequestration, the availability of residue biofuels at different times, and the duration of carbon storage in products [3]. The timing of GHG emissions and removals can be significant to the radiative forcing, and hence the climate impact, over a given time horizon. Analysis of cumulative radiative forcing could be used to compare the climate impact of different building systems, when considering effects due to temporal patterns of GHG emissions and removals. The energy balances of the construction and demolition phases are one-time events during the life cycle of a building. The energy use during the building operation phase, on the other hand, depends directly on the service life span of the building. Another aspect of the building life span is the storage of carbon in wood building materials during the service life. At the

same time, the reference situation has to be defined appropriately, describing the development in the absence of the studied system.

3.10 Spatial system boundaries

A careful definition of spatial boundaries is important when comparing wood and non-wood materials. The use of wood-based materials instead of non-wood materials requires greater quantities of biomass, requiring the use of more land area or intensified forest management [22]. Several methodological approaches can be used to meet this challenge, such as assuming that an equal area of land is available to both the wood-based and non-wood-based product, followed by analysing the energy and GHG balance impacts of various usage options for any land not used for material production. Another approach is the intensification of forest management, which would increase the growth increment and the potential for wood product use. Another issue regarding spatial boundaries is the scaling of analysis from the micro-level to



F.3.6 An award-winning 8-storey CLT-frame building in Växjö, Sweden

the macro-level of national, regional or global scale, to understand the wider implications of wood product use. The total GHG emissions reduction from the available supply of biomass may be increased by exporting biomass to be used in applications that result in high GHG emissions reductions per unit of biomass [23]

3.11 Conclusions

This chapter presents approaches and methods for analyzing greenhouse gas (GHG) and primary energy balances over a building's life cycle. The analysis is highly complex and includes numerous uncertainties and methodological issues. Defining the functional unit, evaluation indicators, and system boundaries are necessary parts of such analyses. A functional unit is the basis upon which different objects or services can be compared. Evaluation indicators are the output parameters used to describe and compare the way in which the different options perform. Important evaluation indicators include GHG emissions, primary energy use, woody biomass consumption and land use efficiency. System boundaries delineate what is included in the analysis and may be identified in terms of activity, time and place. System boundaries related to various activities include building production, operation, demolition and post-use material management, as well as all related energy and material processes required during the building life cycle. All of these phases should typically be considered. The primary energy required for providing the different types of end-use energy and the resulting CO₂ emissions can be determined by considering the fuel cycle, conversion and distribution losses. The values for average or marginal primary energy efficiency and the CO₂ emissions from electricity production could be used in an analysis of a building's life cycle. However, average data would inadequately capture the effect of changes to the system brought about by, for example, innovations in building construction. Cement process emissions, including carbonation and calcination, can be a significant part of the life-cycle GHG emissions of cement products and should be included in GHG impact analysis. The potential use of wood co-products as bioenergy can be compared to the alternative of providing the same energy service with fossil fuels. Allocation is the process of attributing impacts or benefits to a particular part of a process that results in multiple outputs. An allocation of impacts should be avoided if possible, possibly through system

expansion. Temporal system boundaries include the service life of the structural system and façade materials as well as aspects of the wood product life cycle, such as the dynamics of forest growth, including regeneration and carbon saturation, the availability of residue biomass at different times and the duration of carbon storage in products. The establishment of spatial boundaries can be problematic because using wood-based materials instead of non-wood materials requires more land area to capture solar energy and accumulate biomass. However, forest carbon flows have different dynamics when analyzed at the tree or stand level, or at the landscape level. If forests are managed appropriately, the average carbon stock in forest ecosystems can increase over time at the landscape level, combined with a sustainable harvest of biomass. The lifecycle of buildings involves material and energy flows within and between different economic sectors, including the forestry, manufacturing, construction, energy and waste management sectors. To minimize the carbon footprint of the built environment, a thorough understanding is needed of the relative life-cycle impacts and marginal changes caused by different building designs.



- [1] ISO/TS 14067:2013 Greenhouse gases - Carbon Footprint of Products – Requirements and guidelines for quantification and communication. ISO, Geneva
- [2] Bosdevis, B. 2012. Developing benchmarking criteria for sustainable buildings. In: Tarja Häkkinen, ed. Chapter 7 in Sustainability and performance assessment and benchmarking of sustainable buildings.: Final report. Tarja Häkkinen (ed.). Helsinki: VTT Technology. pp. 185 – 236.
- [3] Gustavsson, L. and Sathre, R., 2011. Energy and CO₂ analysis of wood substitution in construction. *Climatic Change*, 105(1-2), pp. 129-153.
- [4] Jungmeier, G., Werner, F., Jarnehammar, A., Hohenthal, C. and Richter, K., 2002. Allocation in LCA of wood-based products: Experiences of COST Action E9 - Part I, Methodology. *International Journal of Life Cycle Assessment*, 7(5), pp. 290-294.
- [5] ISO 14040 Environmental management: Life cycle assessment – Principles and framework. October 2006. Geneva: ISO, Geneva.
- [6] prEN 16485 Round wood and sawn timber – Environmental product declarations – product category rules for wood and wood-based products for use in construction.
- [7] Schlamadinger, B., Apps, M., Bohlin, F., Gustavsson, L., Jungmeier, G., Marland, G., Pingoud, K. and Savolainen, I., 1997. Towards a standard methodology for greenhouse gas balances of bioenergy systems in comparison with fossil energy systems. *Biomass and Bioenergy*, 13(6), pp. 359-375.
- [8] Pingoud, K., Pohjola, J. and Valsta, L., 2010. Assessing the integrated climatic impacts of forestry and wood products. *Silva Fennica*, 44(1), pp. 155-175.
- [9] Poudel, B.C., Sathre, R., Gustavsson, L., Bergh, J., Lundström, A., and Hyvonen, R., 2011. Effects of climate change on biomass production and substitution in north-central Sweden. *Biomass and Bioenergy*, 35(10), pp. 4340-4355.
- [10] Eriksson, E., Gillespie, A., Gustavsson, L., Langvall, O., Olsson, M., Sathre, R. and Stendahl, J., 2007. Integrated carbon analysis of forest management practices and wood substitution. *Canadian Journal of Forest Research*, 37(3), pp. 671-681.
- [11] Betts, R.A., 2000. Offset of the potential carbon sink from boreal forestation by decreases in surface albedo. *Science*, 2000. 408, pp. 187-190.
- [12] Marland, G., Pielke, R.A., and Apps, M., 2003. The climatic impacts of land surface change and carbon management, and the implications for climate-change mitigation policy. *Climate Policy*, 2003. 3:, pp. 149-157.
- [13] Häkkinen, T., Ruuska, A., Vares, S., Pulakka, S., Kouhia, I. and Holopainen, R., 2012. Methods and concepts for sustainable renovation of buildings. Espoo: VTT Technology, pp. 26, 37-64 & 5126.266 p. + app. 51 p.. Chapter 3. pp. 37–64.
- [14] Nässén, J., Holmberg, J., Wadeskog, A. and Nyman, M., 2007. Direct and indirect energy use and carbon emissions in the production phase of buildings: An input-output analysis. *Energy*, 32, pp. 1593-1602.
- [15] Dadoo, A., Gustavsson, L. and Sathre, R., 2009. Carbon implications of end-of-life management of building materials. *Resources, Conservation and Recycling*, 53(5), pp. 276-286.
- [16] Gustavsson, L., Joelsson, A. and Sathre, R., 2010. Life cycle primary energy use and carbon emission of an eight-story wood-framed apartment building. *Energy and Buildings*, 42(2), pp. 230-242.
- [17] Gustavsson, L. and Joelsson, A., 2010. Life cycle primary energy analysis of residential buildings. *Energy and Buildings*, 42 (2), pp. 210-220.
- [18] Ruuska, A., Häkkinen, T., Korhonen, Marja-Riitta, and Myllymaa, T., 2013. Significance of different factors on GHG emissions of buildings. *Suomenympäristö*, 52 p.
- [19] Hawkes, A.D., 2010. Estimating marginal CO₂ emissions rates for national electricity systems. *Energy Policy*, 38(10), pp. 5977-5987.
- [20] IEA (International Energy Agency), 2011. Key World Energy Statistics. Available at: <<http://www.iea.org>> [Accessed on 10 September 2012]
- [21] IPCC (Intergovernmental Panel on Climate Change), 2000. Special Report on Emissions Scenarios. Cambridge: Cambridge University Press.
- [22] Börjesson, P. and Gustavsson, L., 2000. Greenhouse gas balances in building construction: Wood versus concrete from lifecycle and forest land-use perspectives. *Energy Policy*, 28(9), pp. 575-588.
- [23] Gustavsson, L., Eriksson, L. and Sathre, R., 2011. Costs and CO₂ benefits of recovering, refining and transporting logging residues for fossil fuel replacement. *Applied Energy*, 88 (1), pp. 192-197.
- [24] Sathre, R. and Gustavsson, L., 2012. Time-dependent radiative forcing effects of forest fertilization and biomass substitution. *Biogeochemistry* 109(1-3), pp. 203-218.
- [25] Swedish Forest Agency, 2008. National forest inventory and forest and environment. Jonköping: Swedish Forest Agency.



4. Carbon footprint calculation methodology

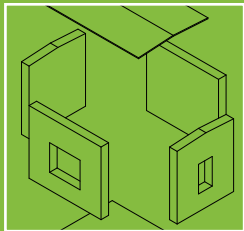

34

4.1 Introduction



36

4.2 Standards related to carbon footprint

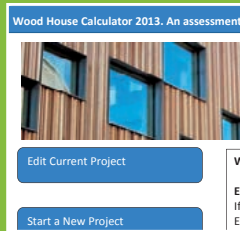

36

4.3 Assessment procedure and assessment tools and their use



40

4.4 Product level

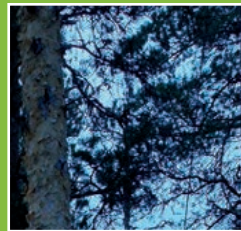

46

4.5 Building level



55

4.6 Conclusions

4 CARBON FOOTPRINT CALCULATION METHODOLOGY

4.1 Introduction

A. Takano

This chapter introduces basic methodologies for carbon footprint calculation of wooden products and building. The contents in this chapter are applied to two environmental impact categories: carbon footprint and primary energy demand.

A building is a very complex system, as it consists of plenty of materials and equipment. Building components, building elements, and the whole building could be analyzed using the LCA methodology. The assessment of building components corresponds mainly to the production stage of building materials. For instance, dominance analysis of building material types used in a building can be done at this level. Building elements is an aggregate of building components, and issues such as the construction stage, prefabrication processes, and building physics are often analyzed at this level. In addition, dominance analysis of building elements are done in order to see which part of a building has a high environmental impact. Finally, a complete life cycle assessment can be conducted for the whole building.

According to EN standards, LCA of construction works is divided into two levels: product level and building level. EN 15804 focuses on the product level, i.e. Environmental product declarations (EPDs) - Core rules for the product category of construction products, while the EN 15978 focuses on the building level, i.e. assessment of environmental performance of buildings. In this chapter, the methodologies are explained following this level definition with the practical division mentioned above in mind.

The LCA of a building is a complex task to handle. Nevertheless, general rules have been set up by the standardization authorities. For instance, comparability of the assessment results is one of the critical issues in practice. In many cases, an assessment result is based on the specific methodologies according to the purpose of the assessment. Therefore, the results cannot be directly compared with each other. This is the same even at the product level. Especially wooden materials can be regarded from diverse aspects because of its specific properties, which most other materials do not have (i.e. carbon storage property, variable properties based on a species, variable moisture content, usability of waste, etc.). The difficulty of handling LCA for the practical user is also an issue to consider.

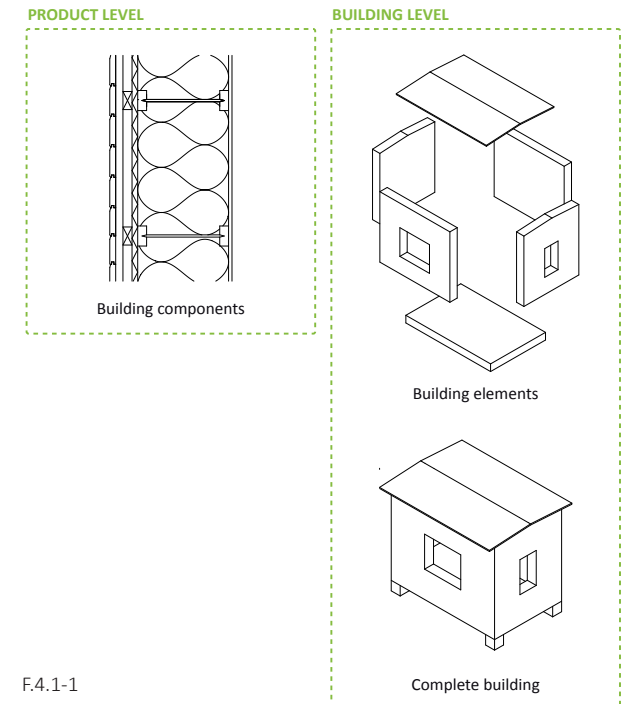

F.4.1-1



F.4.1-2



F.4.1-3

Therefore, one of the most important goals of this project is to discuss relevant methodologies for calculating the carbon footprint of wooden products and building in practical use. The methodologies must be based on sound scientific grounds and in line with the related standards. At the same time, it needs to be explained simply, clearly and realistically as possible and utilized easily.

According to such intentions, the practical methodologies are introduced, traversing several related topics. Simplification of the methods may finally lead to a critical misunderstanding due to the complex nature of building LCA. However, having understood those situations, the aim here is to show a clear and reasonable starting point for practical implementation.

- F.4.1-1 Definition of building level and product level
- F.4.1-2 Sörgård school in Vaggeryd, Sweden
- F.4.1-3 Flyinge Kungsgård in Flyinge, Sweden

4.1.1 Biogenic carbon emissions

D. Peñaloza

The Greenhouse Gas Protocol defines “biogenic” as a product that is produced from living organisms or biological processes, but not from fossilized processes or fossil sources [1]. The carbon neutrality of bio-based products and biomass energy production is a much debated topic, which will be discussed in this section of the book for wood-based construction products.

The biogenic carbon emissions directly attributed to a wood-based product result either from the use of biomass energy during the production phase or from the combustion of the product after the end-of-life stage. These emissions are equal to the amount of carbon sequestered in the growing tree, which provides the biomass for the wood or the energy used. Furthermore, the forest re-growth driven by re-planting harvested trees is also in balance with such emissions. All of this is assuming that the carbon stocks in the forest are not decreasing, a ground rule for sustainable forestry and a common requirement in European forestry practices.

These emissions and sequestration phenomena may be seen as part of an accelerated natural carbon cycle. This is why, if biogenic emissions are to be accounted for in the carbon footprint of a product, the carbon flows in the forest system should also be included in order to cover the full life cycle of the product.

This would increase the level of complexity when calculating the carbon footprint and the final result would not be affected, provided that the biomass originates from forests where the carbon stock is constant over time. In Europe, the total standing forest biomass has increased steadily over many decades, which means that the notion of “carbon neutrality” is a conservative assumption. This is why, for simplicity sake, it is recommended that researchers not account for biogenic carbon sequestration and emissions when calculating the carbon footprint.

In addition, there is a temporal effect from the storage of carbon in wood products that is associated with the atmospheric dynamics of greenhouse gases (see Chapter 3).

4.2 Standards related to carbon footprint

M. Kuittinen, T. Valtonen

Carbon footprint in standards and specifications

The international normative document that is exclusively dealing with carbon footprint is ISO/TS 14067 - Carbon footprint of products. It gives recommendations for assessments regardless of product type. Therefore its instructions are general in their approach. This specification sets rules for system boundaries, input and output data as well as alternative communication formats, depending on the use purpose of the assessment.

A more specifically wood-related standard is drafted in prEN 16449- Calculation of sequestration of atmospheric carbon dioxide. It contains calculation rules that can be applied for calculating the carbon footprint of wood material. It is only applicable to wood material, not wood-based construction products that include other materials as well.

Environmental product declaration

Standard EN 15804 regulates the content and structure of environmental product declarations (EPDs) of construction products in general. Product category rules are developed based on this horizontal standard. They take into account the specific features of different construction materials and thus make it easier to compare the EPDs within the same category. For example, prEN16485 is developed for specifically wood-based construction products.

Impact on global warming is an essential part of an EPD

The ISO carbon footprint standard can be applied to produce a single environmental impact assessment of a wooden product, whereas the EPD includes the assessment of several impact categories. The choice of the approach ultimately depends on the scope and goal of the assessment.

Product Environmental Footprint (PEF)

The European Commission is developing a harmonised methodology for environmental footprint studies covering all goods and services and allowing generation of comparable assessment results. It is based on ISO standards and recognised methodologies such as the International Reference Life Cycle Data System (ILCD). The PEF methodology [1] is likely to be referred to in political instruments as directives and public procurement rules.

Standardized carbon footprint calculations for wooden buildings and construction products

The carbon footprint assessment of building can either use the common LCA methodology (EN 15978 for building and EN 15804 for products) or limit the approach to only a carbon footprint assessment (ISO/TS 14067:2013). Again, the scope and goal of the study define which approach is most relevant.

4.3 Assessment procedure and assessment tools and their use

T. Häkkinen

The environmental assessment of a building requires that information is available on the following:

- qualities and quantities of materials needed for the building;
- environmental impacts of the production of these materials, including extracting, transporting and refining raw materials;
- energy demand of the building to fulfil the required building performance;
- energy supply solutions (electricity, district heat, district cooling, fuels); and
- environmental impacts of the energy supply solutions.

To assess the environmental impacts through the whole life cycle, information is also needed about the design service life, renovation and end-of-life scenarios.

LIFE CYCLE ASSESSMENT

ISO 14040 Environmental management - Life cycle assessment - Principles and framework

ISO 14044 Environmental management - Life cycle assessment - Requirements and guidelines

ENVIRONMENTAL PRODUCT DECLARATIONS

ISO 21930 Sustainability in building construction - Environmental declarations of building products

EN 15804 Environmental product declarations - Core rules for product category of construction products

prEN 16485 Product category rules for wood and wood-based products for use in construction

CARBON FOOTPRINT

ISO TS 14067 Carbon footprint of products

prEN 16449 Calculation of sequestration of atmospheric carbon dioxide

SUSTAINABILITY OF BUILDINGS

ISO 21929 Sustainability in building construction - Sustainability indicators

ISO 21931 Sustainability in building construction - Framework for methods of assessment for environmental performance of construction works

EN 15643-1 Sustainability assessment of buildings - General framework

EN 15978 Assessment of environmental performance of buildings - Calculation method

	CO ₂	CH ₄	N ₂ O
	g/MJ	g/MJ	g/MJ
Anthracite	98.3	0.300	0.0015
Bituminous coal	94.6	0.300	0.0015
Lignite coal	101	0.300	0.0015
Coke	107	0.010	0.0015
Natural gas	56.1	0.010	0.0006
Heavy fuel oil or residual fuel oil	77.4	0.01 0	0.0006
Light heating oil, diesel or distillate fuel oil	74.1	0.010	0.0006
Wood or other solid biomass	112*	0.300	0.004

* Biomass related CO₂ emissions.

F.4.3-1

CO _{2ee}	302,01 g/kg
CO ₂	301,93 g/kg
CH ₄	0,0033599 g/kg
N ₂ O	6,9708E-06 g/kg

F.4.3-2

F.4.3-1 Emission factors for stationary combustion in the category residential. Values are given in net calorific value basis. Data is based on IPCC Guidelines/ Stationary combustion (IPCC 2006). When calculating the CF of the heating energy of a building, the efficiency factor has to be considered additionally

F.4.3-2 Environmental data for the production of diesel oil (density 835 kg/m³) based on the ELCD database

In practice, the environmental assessment procedure requires that applied tools are available. Otherwise the collection of information is too time-consuming to be carried out during any normal design process.

This section introduces principal solutions for the assessment procedure and discusses the significance of different factors for the final assessment result. The focus of the discussion is on carbon footprint assessment.

Data bases – carbon footprint data on building materials and energy

The most important prerequisite for the assessment of embodied carbon footprint of a building design is that information is available on the carbon footprint of building materials.

Environmental product declarations worked out according to a standardized process (EN 15804 and EN 15942) present information on the carbon footprint and other environmental aspects based on the life cycle approach.

To provide comparable information, EPDs must have the same product category rules. The information should also be relevant for the case. EN 15942 tries to support the usability of information in different use situations by defining a structure for the information and thus also by requiring data transparency.

An example of a comprehensive collection of EPDs is published by the German IBU. [1]

INIES [2] is the French database for the environmental product declarations of building products made by product manufacturers and professional associations. The format of data meets the NF P01-010 standard requirements.

In Finland, rather comprehensive data on carbon footprint for building materials is available in the connection of ILMARI tool [3].

Free LCA data is available in the European reference Life Cycle Database (ELCD) [4]. ELCD is a database of the JRC of the European

Commission. It contains more than 300 datasets in ILCD format on energy, material production, disposal and transport. However, the number of building materials is quite low.

ELCD lists databases for search and use [5]. For example, the GEMIS database [6] covers processes for energy (fossil, nuclear, renewable), materials (for example metals, minerals, food, plastics), and transport (person and freight), as well as recycling and waste treatment processes.

Many countries still lack adequate information on the carbon footprint of building materials. Thus, generic and commercial databases such as those published by GaBi [7] and Ecoinvent [8] are often used. Because of its general good availability, German data on building products is also much represented in both free LCA databases and in commercial databases. However, as stated earlier, the use of specific information relevant for the case is recommended. There may be a big difference in the CF of products produced in different countries with the help of different manufacturing processes and energy carriers. Good examples of factors affecting the CF of sawn timber are given in Chapter 5.

Generic information on the carbon footprint of energy carriers is given by IPCC [9] (Table F.4.3-1).

The information of IPCC does not include pre-combustion values. However, these have to be considered in a life cycle approach. Information on the pre-combustion values of energy carriers is given by ELCD [10]. The following table gives an example for diesel oil.

ELCD also gives LCI information about electricity. In principal, the carbon footprint information of electricity and heat can be calculated with the help of International Energy Agency (IEA) statistics [11]. The following table gives an example calculated by VTT for Finnish electricity and district heat in the accordance with both energy and benefit sharing methods and as an average for 5 years (2006 – 2010) [12].

CO₂ emission from a sustainability managed forest is normally regarded as zero in LCI calculations. The current draft for product category rules for wood-based products (prEN 16485) [13] presents

that GHG emissions should be measured on a net basis, equalling emissions to the atmosphere minus removals from the atmosphere, over a given time horizon. In practice, even sustainable forests, where the carbon balance of forest land is basically neutral over the full rotation, are not absolutely climate neutral. This is because the rotation length or re-growth time is typically much longer than the urgent timetable of emission reductions, thus creating a carbon debt with respect to the no-use baseline [14]. In addition, a change in land management practices can reduce the terrestrial carbon stocks. For example, intensified utilization of forest harvest residues leads to declining stocks of dead wood and soil carbon at the landscape level [15]. IPPC gives guidelines for the assessment of land use related emissions, but these are not normally considered in LCIs. However, when land use is considered in the system boundary, the reference situation for forest land use has to be defined appropriately, describing the development in the absence of the studied system.

As described in this section, the limited availability of relevant and comprehensive data on building materials is still a problem in a number of European countries. Another problem is that – although data was available – its ease of use is weak when data has to be manually collected and allocated to the information on the bill of quantities of a design. Applied tools and solutions are needed to enable the assessment of the carbon footprint of alternative solutions and building designs.

Assessment tools

The design phase lacks effective assessment tools [16]. The existing sustainable building (SB) rating methods provide indicators for designers. LCA tools, energy consumption estimation methods and service-life prediction methods are also available, but all these methods entail significant amounts of extra work. The problem is not only about the access to data but also the availability of powerful calculation procedures. Design for sustainable buildings needs integrated methods that provide the process with product information and enable the comparison of design options easily or with reasonable extra work also in the early stages of design. [17]. At present, the assessment process is usually carried out when the design of the project is almost finalized. Environmental

matters need to be considered in the early stage of design, because alterations to the brief may be expensive. The assessment tools should also be reconfigured so that they do not rely on detailed design information before that has been generated by the designer. Environmental and financial issues also need concurrent consideration as parts of the evaluation framework.

Different kinds of assessment tools are already available for the environmental assessment of buildings. The usefulness of assessment tools is mainly based on two issues: the inclusion of environmental data for relevant materials and support for calculation processes. An essential issue is whether the determination of material qualities and quantities is taken place separately or whether the environmental data can be directly linked to the design-based information on the bill of quantities.

The most typical example of a simple assessment tool is an Excel-based tool that supports the definition of building structures, calculation of material quantities, and finally the calculation of the environmental impact by combining the environmental data of materials with the quantity data. The Finnish Log House Calculator is an example of this kind of tools [18] (Figure F.4.3-4).

The SuPerBuildings project [19] studied the possibilities and potential of integrating sustainable building assessment methods with Building Information Models (BIMs). Interoperability and openness of different tools were assessed in terms of data import and data export. For data import, this evaluates whether the tool only enables entering data through its user interface or whether it has the capacity to import data. Several file formats were considered: CAD format, TXT format, XML-based format, IFC). For data export, this evaluates whether the tool offers different ways to store and report the results obtained – different possibilities were considered: Report, File Export with formats like Office format, TXT, XML, IFC). The result of this analysis showed that none of the chosen software solutions are sufficient to perform a comprehensive sustainable analysis with the help of core indicators [20], but a number of software programs have a connection to the BIM and are therefore able to retrieve information from it. For the moment, most of the tools are able to retrieve technical information in order to perform some calculation and edit a report.

	Benefit ⁽¹⁾		Energy ⁽¹⁾	
	Electricity	District heat	Electricity	District heat
CO ₂ fossil, kg/MWh	309	236	222	273
CO ₂ biogenic kg/MWh	121	134	67.5	160
CH ₄ kg/MWh	0.821	0,364	0.709	0,424
N ₂ O kg/MWh	0.000654	0.000397	0.000523	0.000448
GHG kg/MWh	330	245	240	283

1) The energy method allocates the emissions according to the produced energies. The benefit distribution method allocates the emissions to the products relative to their production alternatives.

F.4.3-3

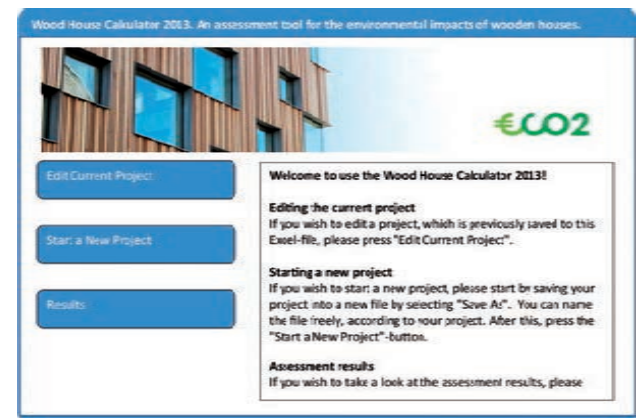

F.4.3-4

F.4.3-3 LCA based environmental profiles for average Finnish electricity (considering net imports)

F.4.3-4 An example of a simple Excel-based calculation tool, which enables the definition of structures and calculation of embodied impacts for log houses.

Recommendations were developed in order to take advantage of the BIM approach [21].

Comparability of assessment results

The comparability of the assessment results depends on the calculation principles. It is impossible to define rules that are unambiguously correct in all situations because relevant rules depend on the scope of the assessment. When LCI or a carbon footprint assessment is required (for example, in the design competition), it is necessary to define the rules (when possible by referring to a standard that actually gives the calculation rules). EN 15978 defines a calculation method for the environmental assessment of buildings. However, this standard alone does not enable fully comparable assessment results because it does not define detailed principles for the carbon footprint assessment of an energy supply.

The following text summarizes the most important factors that affect the assessment results and which should be defined when comparable CF assessment results are required.

Carbon footprint database for building materials

The most recommendable data are EPDs of building products relevant in the country in question and prepared with the same category rules. When this is not possible, relevant data should preferably be provided specifically for the case (for example, by the organizer of the design competition).

System boundary

The system boundary in terms of a building's life cycle stages can be defined by referring to the stages defined in EN 15804 (Section 6.2) and EN 15978 (Section 7.4).

The coverage of the assessment in terms of building-related constructions and technical equipment can be defined with the help of the list given in EN 15978 (Section 7.5).

The main structures of a building (here including the foundation, floors, exterior and interior walls, roof, and balconies) typically account for a very significant share of the overall carbon footprint of a building (stages A1 – A5). According to a parametric study carried out by VTT, the share is typically roughly 70% in residential blocks of flats [22], while windows, doors, glazings, equipments, fittings, floorings and coating materials form the main part of the rest when all embodied carbon of the building is calculated for the investment stage. The consideration of renovation materials may remarkably increase the calculation result (by roughly 30% during a 50-year period compared to the investment stage only). Although the significance of technical equipment is normally low, it may increase a lot when solar cells, solar collectors and air conditioning are used. These may increase the sum by 15–30% during a 50-years period, compared to the base case without this equipment. The share of material-related processes (building, installation, renovation, demolishing) may be roughly 10–15% of the total embodied carbon during a 50-years period. In addition, the construction of building on-site may significantly increase the production-related impacts in the worst cases when the site must be stabilized. In those cases, the order of magnitude of the carbon footprint of a site construction may be the same as that of the whole building [23]. All numerical examples are based on the Finnish parametric case study referred to above

Parameters of carbon footprint

Especially regarding wooden building products and biofuels, the parameters of carbon footprint have to be defined. Especially the consideration of sequestered carbon has an essential impact on the comparability of the results. The following list outlines the essential parameters to be considered:

- CO₂ fossil
- CO₂ biogenic
- CH₄
- N₂O
- Other GHGs as listed by IPCC [24]
- CO₂ sequestered

To maintain the transparency of the calculation result and because of the significance of sequestered CO₂ on the calculation outcome, it is recommended that this parameter is kept separate when it is considered.

Electricity and district heat calculation

An important source for the potential differences in calculation results is the calculation method for the environmental impacts of electricity and district heat, especially in those countries where combined heat and power generation is typical and where electricity and district heat are common methods for the energy supply of buildings, as shown in Table F.4.3-3.

In addition to the calculation method (such as energy or benefit), there are other methodological issues that significantly affect the calculation outcome when electricity and district heat are used. Especially when the environmental impact of alternative energy solutions in retrofitting projects is assessed, it is important to define whether average or marginal/seasonal values are used for electricity. For example, the assessed values for GHG values in Finland (in g/kWh) would be 330 for average electricity (see Table 4.3-3) and 970 for coal-based condensing power. The selection of the calculation basis significantly affects the results.

In addition, the consideration of future scenarios for energy supply is important to define. The share of fossil fuels may significantly decrease and thus the carbon footprint of energy supply solutions will also decrease during the coming decades. As shown, for example, in the MECOREN project,[25] the consideration of future scenarios (the consideration of the expected changes in the emission values of electricity and heat) has a very significant effect on the calculation results. When it is taken into account, the relative significance of material-related impacts normally increases compared to building operation related impacts.

Conclusions

This section gives information about the tools and databases for calculating the LCA of the embodied carbon and carbon footprint of a whole building. To assess the carbon footprint of a building,



F.4.4-1

information is needed on the quantities and qualities of materials being used as building products, on the environmental impacts of products, on the energy demand of the building, on the energy supply solutions and on the environmental impact of the energy supply. In addition, information is required about the service life and estimated renewal periods of the different products and building parts.

Different kinds of databases and tools are available for calculating the environmental impact of buildings. The assessment should always ensure that as relevant data as possible is used. There are large variations between the different databases. The variations may be based both on actual differences in production processes and on energy supply solutions. There may also be differences because of the system boundaries (including geographical boundaries and time boundaries).

With respect to wooden products, the system boundaries and principals used to calculate the carbon footprint can significantly affect the assessment results. In particular, the consideration of sequestered carbon and biogenic CO₂ has an important effect on the results (see also Chapter 3).

4.4 Product level

F. Dolezal, Lauri Linkosalmi, H. Mötzl & D. Peñaloza

Modelling the life cycle of a building starts at the product level. Buildings are a complex system, where products with very different background systems take part, bringing different kinds of uncertainties and challenges.

In this section, these challenges will be discussed with a focus on wood and forest products.

4.4.1 Goal and scope definition

The definition of the goal and scope is the first step of any life cycle study, as it sets the baseline for all the work ahead. The importance of the goal definition is highlighted in every standard, as every methodological choice shall be made based on the study goal, so the results may provide an answer to the questions which drove its commissioning. As the driving forces are particularly different for every study, the goal definition can be regarded as case-dependent, and the aspects they depend on are discussed in this sub-section.

The first key aspect to consider when defining the goal and scope of any LCI-LCA project is the driving forces behind it. The commissioner of the study and what are the results going to be applied for are key issues, and the goal of the study shall be defined based on these. The goal must clearly determine what is the question or problem that the study is meant to solve, so the methodology is tailored to provide the results required to answer it.

At the product level, it is usually building products manufacturing companies who commission LCA studies. It is possible that companies want to learn more about the environmental implications of their manufacturing systems, and so the study is meant to find environmental hotspots and potential for improvement. But even if this is the case, developing Environmental Product Declarations (EPDs), public procurement and product information are on the table as mid/long-term goals.

The commissioner of the study is one thing, but another relevant aspect that must be clearly stated in the goal definition is the intended use of the study. Defining the intended use will have a strong influence in further stages, especially those regarding methodological choices, data collection, reporting and documentation, and reviewing schemes. This is of high importance at the product level, as sometimes commissioners

begin with accounting or decision-support a study, and later intend to use these results for EPDs and marketing. The differences of requirements for these uses may prove significant.

This leads to another key aspect to consider, which is identifying the intended audience. Sometimes the intended audience and the commissioner of the project are the same, but it is not always the case. However, the intended audience must be identified at the same time as the goal and scope, so the displaying of results can be planned well in advance.

The International Reference Life Cycle Data System (ILCD) handbook [1] requires the goal, purpose, intended use, commissioner and intended audience to be clearly stated during the goal and scope definition. Additionally, the handbook classifies studies according to their intended use and if they shall be used for decision-making, and it divides all of its provisions according to this classification. ISO 14044 [2] has the same general requirements to be stated in the goal with a clear statement on whether the results of the study will be used for comparison and if these will be communicated to the public.

All the aspects described above should be stated and taken into account when defining the goal. However, other things must be stated at this first stage, such as the functional unit used. It is common to use material amounts as a functional unit in the product level. Volume or mass units may be used as long as assumptions or values related to density or specific weight are provided with the result. Density values provide a way to relate volume and mass amounts, so there is a way to convert the results of the analysis from one functional unit to the other. It should be mentioned that moisture content should be taken into account when performing this kind of calculation, as it can influence the density and energy content values of wood products.

Nevertheless, sometimes the function provided by similar amounts of different materials can be different, which means material amounts might not be adequate functional units. A good example to illustrate this issue is the choice of insulation materials, which might have different conductivity, because the same amount of different materials could have different insulation capacity. This would directly affect the function of the material, and cannot be directly related to the material amount. This is why the functional unit must be chosen carefully, depending on the kind of material under study.

The reference flow must be also clearly identified at this stage. It is defined by ISO 14040 [3] as the measure of the output(s) of the process(s) required to provide the function identified as the functional unit. The role of the reference flow gains importance when the results should be used for comparison between systems, as this comparison should be done only in terms of this reference flow.

There are other aspects that must be clearly defined at this stage as a way of planning how the LCA will be performed. Issues such as the allocation method, the system boundaries, the data requirements, the chosen cut-off criteria, the main assumptions and the uncertainties and limitations of the study should be clearly identified at this stage as part of the scope of the study. They are further discussed in the coming sections.

4.4.2 System boundary for wood based products

The system boundary defines the borders for the study, as it specifies which unit processes are part of the studied product system and which processes are excluded. The boundaries of a product system separate it from natural systems and other technosphere systems, which are always out of the boundaries. According to different standards [4, 5], the system boundaries should describe the main elements of the physical system. The product system should be modelled in such a way that all the

F.4.4-2

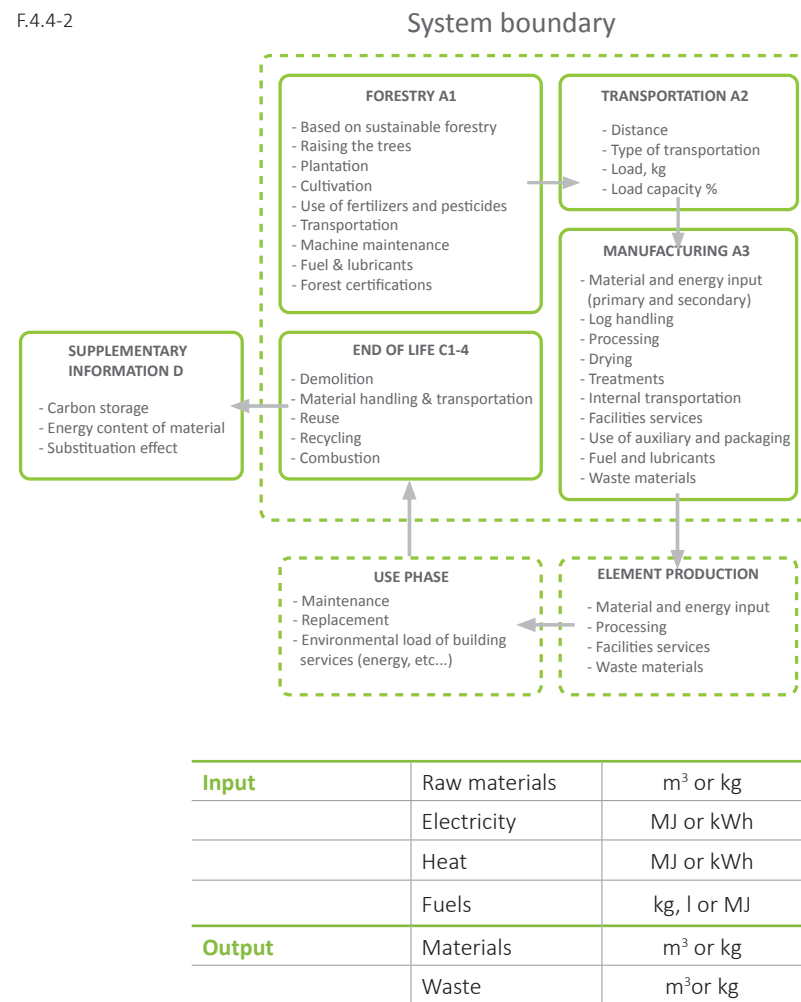

F.4.4-3

F.4.4-1 Detail of the facade from the Student housings in Kista, Sweden

F.4.4-2 System boundary of wood based construction materials

F.4.4-3 Inventory data for unit process

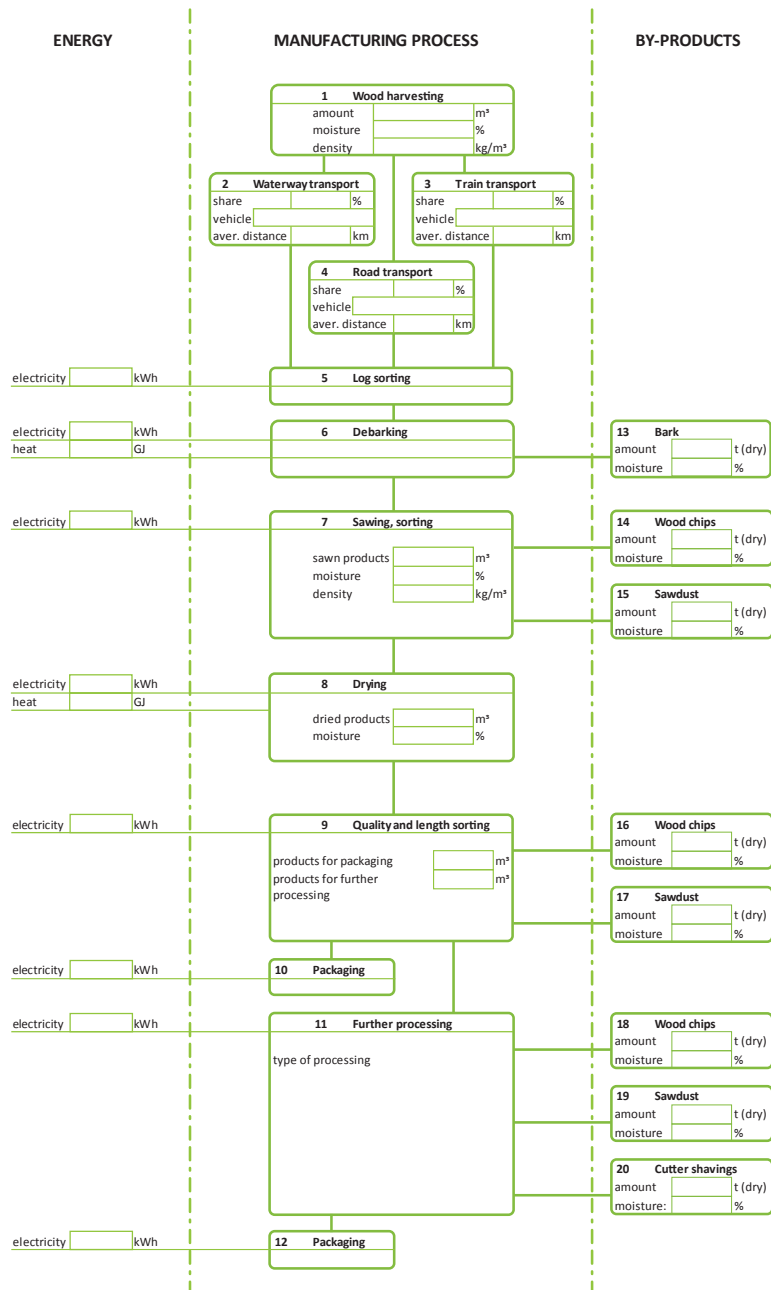

input and output flows are elementary flows within the boundaries.

According to ISO 14040 [3], the following unit processes or flows should be taken into consideration:

- acquisition of raw materials;
- inputs and outputs in the main manufacturing/ processing sequence;
- distribution/transportation;
- production and use of fuels, electricity and heat;
- use and maintenance of products;
- disposal of process wastes and products;
- recovery of used products (including reuse, recycling and energy recovery);
- manufacture of ancillary materials;
- manufacture, maintenance and decommissioning of capital equipment;
- additional operations, such as lighting and heating.

In the specific case of building materials and their manufacturing phases, modules A1-A2-A3 [4] must take into consideration raw material extraction and processing, transportation of raw materials and manufacturing processes. Furthermore, it must include all materials, products and energy, as well as waste processing up to the end-of-waste phase or disposal of final residues. All this information could also be stated as one aggregated result for modules A1-A3. Figure F.4.4-2 shows a typical system model for wood construction materials.

Raw material extraction (A1)

Forestry is the main source of raw materials for wooden building materials. Some of the co-products are recycled during the process, but this might differ for different regions in Europe. When recycling of co-products takes place and

recycling loops appear, it should be dealt using physical allocation. A basic assumption in the raw material acquisition process modelling is that it is based on sustainable forestry. The forestry process should take into consideration the cultivation and plantation of trees, as well as the use of fertilizers and pesticides. All machinery work should be considered, as well as infrastructure, transportation, maintenance and harvesting processes in the forest.

Transportation (A2)

The transportation of the raw materials from the acquisition place to the processing place needs to be included as well. Every transportation mode used like road, rail or ship should be reported including the transported distance (km) for each, as well as the respective load (kg), filling factor (%) and type of vehicle.

Manufacturing (A3)

The production phase includes gate-to-gate data; all material and energy inputs to the production site must be included, as well as waste materials. Manufacturing activities such as sawing and planing usually generate co-products such as sawdust or chips. These by-products are usually used for energy production, creating recycling loops, or allocation issues that should be handled using physical allocation.

End of Life (C1-C4)

The end-of-life module includes the processes of demolition, transportation, waste processing and disposal. The end-of-life module is of high interest, as different materials have very different disposal processes that may be changed for different locations and time boundaries. The environmental benefits from disposal processes or substitution effects should

F.4.4-4 Manufacturing flow for the sawn timber

not be included in these modules and shall be included in the following module (D) instead.

Supplementary information (D)

Benefits and loads beyond the system boundary should be shown as a separate number in the supplementary information module D [4]. These kinds of benefits or loads for the wooden building products may be carbon storage, the energy content of material, recycling benefits or re-use potential, including substitution effects. These benefits and loads must only be shown in this module and should not be aggregated in the total carbon footprint of the product.

4.4.3 Data inventory

In Life Cycle Assessment, the most crucial issue is the system boundary; moreover, the quality and coverage of data is an important aspect. Data can be monitored from the studied process system, or generic data can be monitored from databases or environmental product declarations.

All data which is used in Life Cycle Assessment shall be listed and documented. Data inventory and sources should be transparent and possible to verify later on. General data can be used when it is justified according to goal and scope decisions; case-specific data should be used when it is studied certain system. Table F.4.4-3 shows the basic idea of data inventory for one unit process.

Inventory data for a whole system can be present as a flow chart. Figure F.4.4-4 shows an example of sawn timber manufacturing. All phases of manufacturing are taken into consideration in this flow: material, energy and by-product flows.

4.4.4 Allocation of environmental impacts

Manufacturing processes in the wood working industry often produce multiple products. Those products can either be main products or by-products, and the environmental burden of the process is distributed among these multiple products. It is recommended to divide the unit process to be allocated into two or more sub-processes or to expand the product system to include

additional functions related to the co-products. In some cases, it is not possible to use a wider approach; in that case, allocation within the manufacturing process needs to be used.

Wherever possible, according to ISO 14044 [2], allocation must be avoided. Allocation means partitioning input or output flows from a process or a product system between the product system under study and one or more other product systems.

If a process must be divided but data is not available, inputs and outputs of the verified system should be divided by its products or functions in a way that the separation shows basic physical relations among them. This is what allocation is about.

If related co-production processes are not independent and can't be separated, allocation has to consider the primary purpose of processes and assign it to all relevant products and functions adequately. The scope of the production site and related processes, usually shown in concession, should be considered. Processes with a very low contribution to the revenue can be neglected. A contribution to the revenue of 1% or less is considered very low.

According to EN 15804 [4], if the processes cannot be sub-divided, allocation of a related co-production has to be carried out as follows:

- Allocation has to be based on physical properties (mass, volume) if the difference in the revenue generated by these co-products is low. A difference of 25% in revenue from the co-products is regarded as high.
- In all other cases, allocation has to be based on economical values.

Physical allocation

Physical allocation means that physical properties of the different flows are used to allocate the environmental loads from the process. Mass and volume are usually used for physical allocation, but other physical properties (such as energy or exergy) could be used as well.

Economic allocation

Percentages for economic allocation are identified by given prices or price-relations of products. Economic allocation might be seen as a kind of mass or volume allocation, but weighted by the economic value. The main problem of economic allocation is that, compared to mass or volume, prices are not as stable and depend on and vary heavily with market conditions and fluctuations. For economic allocation of wood, volume should be considered instead of mass values.

Discussion

The use of economic allocation factors changes the weighting of products compared to simple mass or volume allocation. Therefore, in a second step, these changes have to be adjusted by calculating allocation corrections for each product.

Co-products from the same process may have different moisture contents, which could directly affect the physical relations, when allocation is based on such as mass and volume. This is why they should be approximated using available information such as ecoinvent database modules for wood [5] or from the literature. Utilize economics values; they can be varied according to the end use of products and time. Sometimes even economic values are not available, or price can be an internal one within the company. In this case, percentages of price relations have to be claimed. Experience shows that these relations usually can be provided immediately. In most cases, mass or volume are not appropriate figures to describe the technical value of a product, as they do not reflect the main characteristics of the product. With mass allocation, large burdens are attributed to low-value products if they are produced in large amounts, e.g., rock as a side product of gold production.

Emission measurements of boilers and cogeneration plants are taken into account if data is provided by producers and applied to the production. Afterwards, the main product is modelled in a second module, where allocation is applied on the product. Additional inputs that are only related to the main product (such as packaging) are considered at this stage.

It should be mentioned that the choice of allocation method has a strong influence on the results of life cycle assessments and carbon footprint. Considering the example of gold production, relations can vary heavily due to different allocation methods.

Recommendation for allocation

In principle, the selection of allocation method is case-dependent. When deciding which method to apply, the circumstances of the specific process and co-products should be evaluated. Nevertheless, given the variability in economic value of co-products, physical mass allocation is recommended for wooden products as the default methodology. Since environmental impact is a physical phenomenon, it should not be affected by fluctuations in the social and economic situation.

4.4.5 Interpretation of results

The final stages of every LCA study should always take practitioners back to its goal. All the work involved during this stage strives to find whether or not the purpose of the study was fulfilled. This section will cover the identification of the relevant aspects from the results and conclusions, as the following section covers the checking of the robustness of results.

Identifying highly significant processes or “hot spots” is often relevant because of their strong influence on the total environment impact of a product. This is even more relevant for accounting studies, as their purpose is to identify processes where there is higher potential for environmental improvement for the studied product.

In studies where the goal does not include an environmental impact assessment, the interpretation of results is less relevant. For this kind of study, the main objective is to model and inventory the system for a specific product or material, and delivering only a set of comprehensive data is required. This is often the case in EPD development, where the challenge is fulfilling the requirements for a public EPD defined in the standards and presenting the results in a way that all public stakeholders can understand.

These requirements are important for the concrete case of EPD development. The core rules for the product category construction works EN 15804 [4] establish a set of requirements for reporting and documentation. It also includes requirements for verification of the validity of the EPD, as well as the documentation required for this verification. Furthermore, the EN 15942 [6] standard establishes a communication format for EPD. All these requirements must be revised and fulfilled if the results of the study are to be used for public information.

Transparency of the results is very important for any life cycle study. The sources of background data must be very clear, as well as how it was obtained or inventoried, what kind of process and technology it represents, what is included in the data, and possible sources of uncertainty regarding specific data sources.

Some data can be cut-off. Cut-off criteria and rules are used to exclude some inputs and outputs in an LCA study. The use of cut-off criteria within a study needs to be clearly understood and well described, as it should not be used to hide data or results. All excluded inputs and outputs must be comprehensively justified and documented in the final report. Standard EN 15804 [4] describes specific rules and criteria for the cut-off. Different cut-off criteria should be used to determine which inputs are to be included in the assessment, criteria regarding, for example, mass, energy and environmental significance. To cut off inputs according to only one factor may cause the omission of some important results. Therefore, decisions to cut off any flow need to consider preferably the mass and energy contribution as well as the environmental significance [2].

The conclusions drawn from the study shall be consistent with the study goal. The interpretation of results should lead to the fulfilment of the original study goal, whatever it is. The questions that the commissioners raised by performing the study shall be clearly answered by the results, otherwise the methodology and the system model shall be revised.

4.4.6 Uncertainties and limitations

Every LCA study must identify and state the uncertainties and limitations of its results. This is important not only for studies intended to be used for information and marketing, but also for every study because it affects the reproducibility of the results by other practitioners. It is also possible to assess the robustness of the results if it is required or planned in the goal and scope stage. In this final section, the most common sources of uncertainty will be discussed, including some ways to deal with these uncertainties.

First, it is important to distinguish between two different concepts in this regard: uncertainty analysis and sensitivity analysis. **Uncertainty analysis** deals with the uncertainties in the data used and the assumptions made to obtain this data. **Sensitivity analysis** deals with the sensitivity of the results to changes in the methodological choices used in the study.

Imprecise data is what uncertainty analysis deals with – imprecisions which appear when processes can have different environmental impacts if they operate under different conditions or when processes are modelled using different assumptions [7].

At the product level, a comprehensive way to deal with this is to present an interval instead of an average result. If a dataset or a process brings uncertainty to the results and it proves to have a significant contribution to the environmental impact of the products, the results can be presented as an interval of potential environmental impact from the product. This would give the audience a full and realistic picture of the environmental potential from the specific product. This is a comprehensive way to deal with uncertainty, but also requires more resources as practitioners need to obtain or inventory further data.

One usual source of sensitivity for any LCA study is the **excluded processes**. It is easy for any kind of audience to have a view of the processes that are included in the study, as this is usually described in the system boundaries section and diagrams. Nevertheless, the excluded processes are not as straightforward to see, and practitioners who intend to use the study results might bring uncertainty without realizing it.

It is not clear how much the environmental impact from these processes will affect the results of the study. It is difficult to know if this influence is high or low, as the only way to know this for certain is to actually include these processes. The reasons for their exclusion are often justified by previous findings that show a minimal influence on the result or a lack of relevant data to model these. Anyhow, it will affect the completeness of the results.

The best way to deal with this issue is to perform a sensitivity analysis where these processes are included in the model, making some basic assumptions such as transport distances or modes, material requirements, emission factors, and technology used. The effect of this change must be analysed in a comparative way, assessing how much the overall results would change if these processes are excluded or not.

The robustness of results might also be sensitive to the **representativeness of data**. At the product level, the data is often inventoried by a specific manufacturer. Sometimes it is possible to include several sites, but it is possible that manufacturers have only one production site. Production sites represent only one kind of technology they use, which might be out of date or modern. Production sites can also represent a common technology in a specific country, while the electricity system in each country may also greatly influence the results.

This means that the results obtained at the product level are often not very representative of a product type. They represent the specific technology of the manufacturer, which represents a specific time period or a specific time of year. They also might be representative of a country, a region, a company or even just a production site. If results are not representative, other LCA practitioners would not be able to reproduce them easily because averages or simply other types of data might often be preferred.

The best way to deal with this issue is to gather representative data from the beginning, inventorying as many different processes, technologies and sites as possible. Then average and specific results would be available, and the representativeness limitation would be avoided. This requires additional resources for the project, so it may not always be possible. As with all other methodological choices, this choice will depend on the study goal and purpose.

It can also be argued that most of the LCA studies performed at the product level aim to represent the production system of a specific company, a specific site or a specific process, especially if the LCA is carried out as part of the development of an EPD. For these cases, representativeness would not be an issue, and would rather be a normal thing to have a very specific result.

Sometimes LCA practitioners find surprising results, or simply doubt some of the methodological choices made. **Variation analysis** is a good alternative in these cases when a variation in the methodology is explored and alternative scenarios are calculated based on a single assumption, data choice or calculation done differently [7]. If the results do not change much, it means that this particular choice would not influence the results, so the study may go on. If the results change significantly, the methodology shall be revised.

Wood products usually have uncertainties regarding the selected allocation method. Since multi-output processes and recycling loops are quite common, the way in which allocation issues are dealt with often brings uncertainty to the results. The best way to deal with this is to do a variation analysis and test other allocation methods in processes that influence the results the most.

The choice of data for electricity or heating systems is often a very influential one, and wood products are no exception. Often production facilities use a great deal of biomass by-products to produce energy for their own process, but additional electricity or heat is always required. Modelling electricity systems is always challenging, as many variables affect the outcome, such as assumptions regarding technology, fuel, and energy carrier. Furthermore, whether to use average mixes, local specific data, marginal data or a specific technology influence the results as well. The best way to deal with these uncertainties is a variation analysis, where different scenarios using different energy models are modelled and the implications of this choice are comprehensively described.

Standards deal with uncertainties in similar ways. The ILCD handbook for LCA recommends a completeness check (to see if the cut-off criteria are met), a sensitivity check (to test the accuracy and precision of results) and a consistency check (if the

results are consistent with the study goal) [1]. Furthermore, ISO 14044 [2] has the same recommendations, while emphasizing the importance of choosing evaluation techniques that are consistent with the goal and purpose of the report, especially as different uses imply different levels of robustness and verification.

Finally, the results of the uncertainty and sensitivity analysis may have different outcomes. On one hand, it might be observed that the uncertainties from the data used and the method followed do not affect the results. If this is the case, the results of the study will be more reliable. On the other hand, the results might turn highly sensitive to changes in method and data. This would mean that more reliable data or a more relevant or more complete system model is needed.

- Key aspects about the goal and scope definition stage are functional unit.
- Reference flow and purpose of the study
- Both economical allocation and physical allocation method have merit and demerit.
- Mass-based physical allocation is recommended for wood-based products

4.5 Building level

4.5.1 General issues – System boundary condition

A.Takano, A. Hafner, S. Ott, S. Winter & A.Dodoo

Carbon footprint analysis of buildings is more complex than that of many other products due to the following: the long lifespan of most buildings, with impacts occurring at different times during the life cycle; the possible changes in form or function during the lifespan of the building; the multitude of different actors, including designers, builders and users, that influence the life cycle impacts of the building; and the lack of standardization of building design and construction, making each building unique [1]. Furthermore, buildings are complex systems of multiple components and functions and are dynamic due to their different life cycle stages, which are interlinked with energy supply activities. For wood-based systems, carbon footprint analysis should take into account all the inputs and outputs over time across every stage of processing, from forest regeneration and management, harvesting, product processing, product use, maintenance and final disposal of the wood.

Figure 4.5-1 shows the activities and flows linked to the life cycle of a wood-based building. An analysis of this system provides information about the consequences of changes in the level of production of a product and may include effects both inside (direct) and outside (indirect) the life cycle of the product. This wide system boundary is important to draw conclusions on the full carbon flow connected to a building, as the system includes a wider scope and time frame.

On the other hands, practical simplification of the system boundary may be required, for instance, where the purpose of assessment focuses on system building as such. The red line in Figure F.4.5-1 shows a simple system boundary for practical implementation of a carbon footprint analysis as an example. An assessment of this system provides information about the impacts of processes to produce, consume and dispose of an average single unit of a product, but does not include induced effects from changes in outputs, such as shifts in production and emissions from other products that are displaced by the product being assessed. This approach aims at describing environmental properties of a building in its life cycle. Different carbon footprint analyses can be

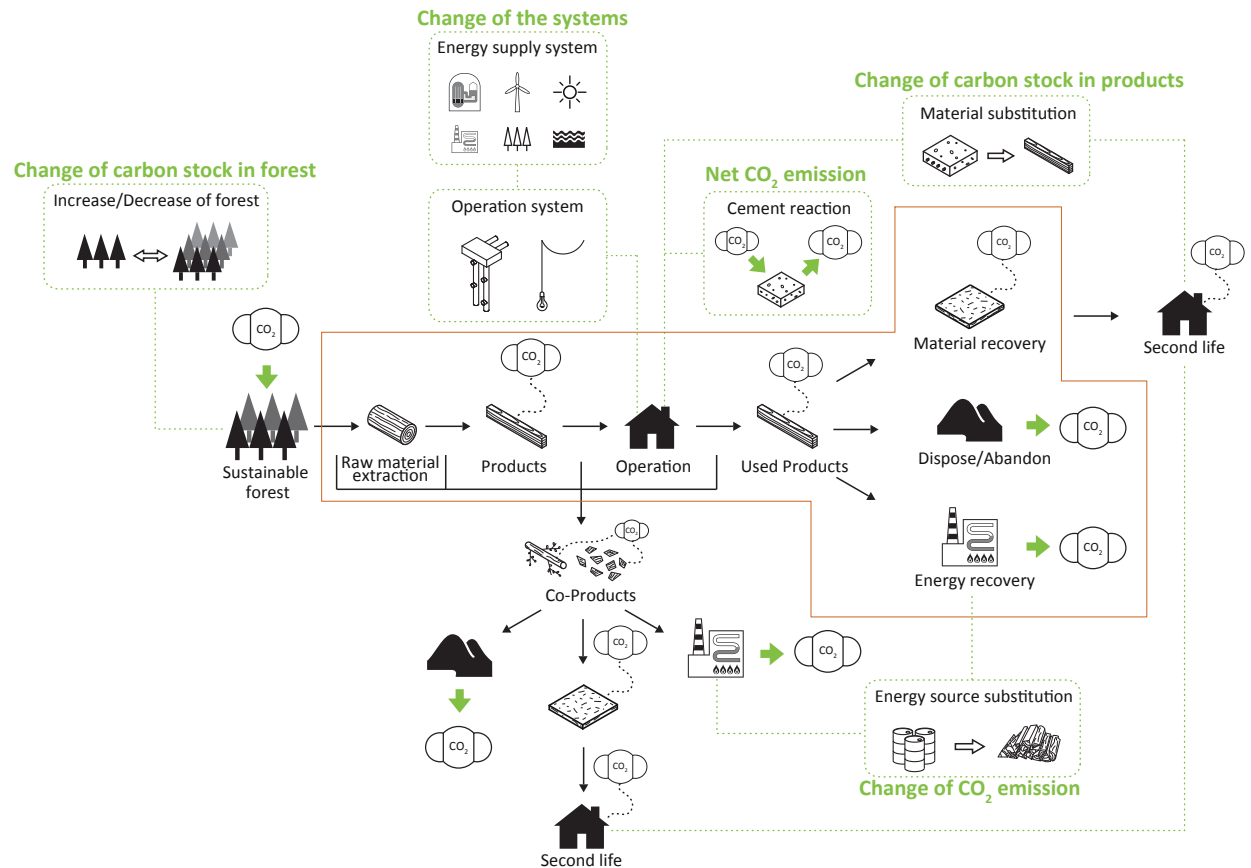

F.4.5-1 Holistic picture of carbon footprint related to a wood-based building system and simplified system boundary (red line) for the system building including only direct environmental effects.

Description	Carbon dioxide emission
Production /retrofitting phase	Fossil fuel use for material production and building construction.
	Net cement reaction (calcination)
	Wood residues
	Carbon stock changes in forest.
Operation phase/ Service life	Fossil fuel for building operation (space heating, tap water heating, electricity for ventilation and for household and facility management)
	Carbon uptake in re-growing forest.
	Net cement reaction (carbonation)
End-of-life phase	Fossil fuel for end-of-life activities- material demolishing, transportation, recovery.
	Wood residue recovery
	End-of-life benefits of materials e.g. concrete, steel etc.
	Net cement reaction (carbonation)

compared across differing technologies or different co-products of a process with the same system boundary.

The system boundary condition is an issue that needs to be considered according to the scope and goal of the assessment. A different system boundary requires fulfilling slightly different methodological issues. Regarding the two different system boundary conditions mentioned before, the methodological points are discussed in the following sections of this chapter.

4.5.2 Full carbon footprint analysis

A. Doodoo, R. Sathre

General guidelines for carbon footprint analysis are outlined in ISO/TS 14067 (ISO, 2013). According to the technical specification, a scientific approach should be used to assess a carbon footprint with emphasis on relevance, completeness, consistency, accuracy, and transparency for the entire life cycle of a product. According to the International Standards Organization [2], ISO 14067 builds on existing standards in the ISO 14000 category and is consistent with the ISO standards for life cycle assessment.

Holistic analysis of the carbon footprint of wood vs. non-wood based building systems is a complex issue. Wood substitution raises two important questions: (1) what would happen without the substitution (the performance of the reference system)?, and (2) how will the substitution system perform? In principle, marginal changes will occur in both the reference system (the non-wood product system) and the substitution system (the wood product system). Gustavsson and Sathre [3] discussed key issues to address to accurately analyze the carbon footprint of building and construction systems. These issues include a definition of appropriate functional units, establishment of effective system boundaries in terms of activity, time and space, and choice and quality of data.

Unit of analysis

Defining an appropriate unit of analysis or functional unit for comparing different systems is an essential step in carbon footprint analysis. Different functional units have been used in the carbon footprint analysis of buildings [4]. These units include the complete building or unit area (m²) of a building's gross, living or heated floor area. Functional units based on material volume, mass, or isolated structural characteristics of building components are inadequate as the function of different materials cannot be

F.4.5-2 Main activities and flow in a complete carbon footprint analysis of a wood or non-wood-based buildings

directly compared and materials may often fulfil more than one function (e.g. structural support and thermal insulation). A robust functional unit must reflect the complex interactions between multiple system components and functions. This is done by considering the complete building.

System boundaries

System boundaries of carbon footprint analysis must be broad enough to include all significant impacts. The ISO/TS 14067 technical specification on carbon footprint analysis states that a study shall "consider all stages of the life cycle of a product when assessing the [carbon footprint], from raw material acquisition to final disposal" and to "include all GHG sources and sinks together with carbon storage that provide a significant contribution to the assessment of GHG emissions and removals arising from the whole or partial system being studied" (ISO 2010). Analysis of carbon footprint of buildings in a life cycle perspective should include "all the upstream and downstream processes needed to establish and maintain the function(s) of the building, from the acquisition of raw materials to their disposal or to the point where materials exit the system boundary either during or at the end of the building life cycle" [5]. All CO₂ flows and stocks linked to buildings (Table F.4.5-2) need to be considered in a life cycle

optimization. Activities, temporal and spatial aspects of the system boundaries should be considered in a carbon footprint analysis.

Activities-related system boundaries

Activities-related system boundaries encompass building production, operation, end-of-life, and all related energy and material processes required during the building life cycle.

Production phase

The production phase of buildings encompasses extraction of raw materials, transport and processing of raw materials into building materials, fabrication and assembly of materials into a ready building. Biomass residues obtained from forest thinning and harvesting, wood processing industries and construction sites must be taken into account [6].

For those materials extracted directly from natural deposits (mineral ores, for example), an appropriate system boundary for the calculation of the carbon footprint begins at the point of extraction. For biological materials that are cultivated (for example, wood from sustainably managed forests), the analysis includes the technological (i.e. human-directed) energy used for biomass production. This includes the GHG emissions from fuels used for the management of forest land, the harvesting of timber, and the transport and processing of wood materials.

Energy input is required to extract, transport and process building materials, and this may result in GHG emission. In cases where the type of fossil fuel is known (e.g., end-use fuels used for material production in well-documented industrial processes), the CO₂ intensity of that fuel is used in carbon footprint calculations. In cases where there is some uncertainty as to the appropriate choice of fuel (e.g., the fuel that is used to produce marginal electricity), a “reference fuel” can be employed to determine the significance of the carbon intensity of the fuel that may be used [7]. Coal and fossil gas are two potential reference fossil fuels, representing the high and low ends, respectively, of the range of carbon intensity (kg C emitted per GJ heat energy released) of

fossil fuels, thus indicating the range of uncertainty introduced by the fossil fuel used.

To estimate the carbon footprint implications of building production, the total material mass inputs for buildings (including waste on construction sites) should be accounted for. The amount of building waste typically varies between materials and also varies between construction sites. In the absence of specific data, waste material generated during construction of the buildings may be estimated by increasing the material quantities in the finished buildings by specific percentages that are representative for each material. For example, Björklund and Tillman [8] estimated material waste percentages for Swedish construction sites. Examples of these values are 1.5% for concrete, 7% for insulation, 10% for plasterboard and wood, 15% for steel reinforcement, and 5% for most other materials. These values may vary depending on whether the assembly is on-site or prefabricated.

The carbon dynamics of cement-based products include calcination and carbonation. CO₂ is released during the production of Portland cement due to the calcination reaction, when calcium carbonate is heated and broken down into calcium oxide and CO₂. Carbonation removal is less than the calcination emission, thus the net process reaction emissions can be a significant part of the carbon footprint of cement products [9].

Different physical processes can be used to produce the same material, each process with unique requirements and effects on the environment [10]. This may result in significant differences in the carbon footprint for the same type of material. Recent ISO specifications on carbon footprint calculations state that data “shall be representative of the processes for which they are collected” [11].

In the building construction stage, diverse materials are put together into a complete building. Several factors may affect the primary energy used for building construction, including the method of construction and the type of building materials [12]. In contrast to site-built systems, modular building systems are typically prefabricated off-site as volume elements, and then transported on-site and assembled on site-built foundations. The

GHG emission for building construction may also vary, depending on the parameters included, e.g. fuel use to transport construction equipment, workers and off-site fabricated components. To determine the carbon footprint resulting from primary energy use for building assembly activities, it is necessary to know the fuel mix. In the absence of specific data, [13] assumed that half of the construction-related primary energy use was for end-use electricity, and half was diesel fuel.

Biomass residues are generated during silviculture, harvesting, primary processing when logs are sawn into lumber, and in secondary processing for products such as doors, windows and glue-laminated beams. Residues are often used as an energy source in sawmills and wood kiln and as fuels in heat and power plants in Sweden. Residues may also be redirected to non-wood product streams such as pulp and paper, or used as a raw material for particleboard and other composite wood products. Gustavsson et al. [14] describes a methodology to estimate the carbon footprint dynamics of residues from the wood chain. Parameters considered include the mass of different types of residues available from the wood product chain and their heating values, and the energy used to recover the residues.

Bottom-up and top-down approaches are two complementary methods to model production phase carbon footprints. A bottom-up approach, based on process analysis, begins with detailed disaggregated information for a system and then generates aggregate system behaviour to characterize the relationship between the individual components of the system [15]. This approach provides specific information about the individual processes and systems studied, allowing for detailed comparison and optimization. The top-down approach, based on environmental input-output analysis begins, with the aggregate information for a system and then proceeds to disaggregate this to characterize the components. Carbon footprint calculations of bottom-up models may have a high level of accuracy but may suffer from truncation errors, as they may not recognize indirect flows in a studied system (see, e.g. [16]). In top-down models, the problem of truncation error is addressed as indirect flows are taken into account when the aggregate system is considered. However,

top-down models suffer from a lack of detail and precision at individual process levels.

Operation phase

Energy-related activities in the operation phase of a building include space heating and cooling, tap water heating, ventilation, and electricity use for lighting and appliances. The space heating demand of a building depends on the interactions of several thermo-physical properties, including the envelope thermal properties of buildings, orientation, glass area, heating and ventilation systems, heat gains from lighting, appliances, human bodies and solar radiation, and operation schedule, indoor temperature, geographical location, and climate besides outdoor temperature. Furthermore, a comprehensive analysis of the carbon footprint of the operation phase of a building may include the thermal mass effect. Effective thermal mass material can absorb and store significant amounts of heat, and this can help to level out temperature variations. Thermal conductivity influences the time lag of absorbing or releasing heat. The effectiveness of thermal mass in buildings depends on the interactions of several parameters, including climatic location, insulation, ventilation, load profile and the occupancy pattern of buildings [17].

Detailed dynamic hour-by-hour models are needed to accurately account for the heating and cooling loads of a building and for one-, two- and three-dimensional heat flow modelling of various building envelope configurations. Commonly used dynamic state models include ESP-r, Energyplus, TRNSYS and VIP+ [18].

The various processes along the energy supply chain, from the extraction of raw material to refining, transport, conversion to heat and electricity, and distribution to the user can be performed with different energy efficiencies and with varying emissions. All the energy inputs for these processes need to be included for a full description of a particular energy system. A comprehensive analysis of the carbon footprint of the operation phase of a building needs to include the entire energy chain, from natural resource extraction to final energy supply, taking into account the fuel inputs at each stage in the energy system chain and the energy efficiency of each process. The heat demand of a building

can be provided by different end-use heating systems and energy supply technologies, which can result in significantly different carbon footprints [19], [20]. Maintenance and retrofitting phase

Maintenance and retrofitting tasks include periodic component replacements and aesthetic and energy renovations. Maintenance and material replacement activities can have a significant effect on life cycle impacts and can vary substantially as a function of material; hence, they are generally included in a carbon footprint analysis. The building structure can be assumed to have the same life span as the building and basically no maintenance need, regardless of structural system used. However, different exterior surface materials and some other building materials may have significantly different service lives or maintenance requirements.

Depending on the energy efficiency standard to which buildings are originally built, there may be significant CO₂ benefits of retrofitting buildings to a higher energy efficiency standard [21]. Evaluation of the overall effectiveness of energy efficiency retrofitting measures requires a system-wide perspective that considers the complete building life cycle phases and heat supply systems.

End-of-life phase

End-of-life management options for building material may include reuse, recycling, energy recovery and landfilling with or without the capture of landfill gas. The end-of-life management of building materials is inherently uncertain, as this life cycle phase will occur in the future. Still, a carbon footprint analysis of a building must consider the fate of the building material at the end of their service life, as the ISO draft standards [22] require that “all the GHG emissions and removals arising from the end-of-life stage of a product shall be included in a [carbon footprint] study”. End-of-life management of wood products is the single most significant variable for the full life cycle energy and carbon profiles of wood products [23]. The energy used directly for demolition of buildings is generally small (1-3%) in relation to the energy used for material production and building assembly [24]. The percentage of demolition materials that is recoverable is variable and depends on the practical limitations linked to the building design and whether material recovery is facilitated. Methods

of accounting for the climate effects of recycling materials are still at an early stage of development, particularly in the context of potential policy instruments for climate change mitigation. End-of-life materials are increasingly recovered, as efficient management of post-use building materials is a priority in many European countries [25].

Re-use or reprocessing of materials at the end of the building life cycle can have significant effects on the net carbon emission [26]. Optimization of end-of-life product recovery and recycling systems may become increasingly important in the future for wood, concrete and steel. The climate performance of non-wood materials can also be significantly affected by post-use management. Production of steel products from recycled steel scrap requires less primary energy, and emits less CO₂, than production of steel from ore. However, the analytical methodology used (e.g. closed-loop, value-adjusted substitution, cut-off) will affect the calculated benefits. Post-use management of concrete can also lead to reduced net CO₂ emissions by promoting increased carbonation by, e.g., crushing the concrete and leaving it exposed to air. Nevertheless, wood material has relatively more opportunity to improve its climatic performance, due to its dual role of both material and fuel [27].

Recovery of energy by burning the wood is a resource-efficient post-use option where material reuse of recovered wood is not practical. The use of recovered demolition wood for biofuel directly affects the life cycle carbon balance of the material. The use of the biofuel to replace fossil fuels, thus avoiding fossil carbon emissions, also affects the carbon balance.

Carbon dynamics in landfills are quite variable and uncertain and can have a significant impact on the carbon footprint of wood-based systems. Landfilling of wood should be avoided as is not allowed in the EU; thus this option is not expected to be significant in European analyses.

Temporal aspects of wood-based products and forest

Consideration of system boundaries related to time is an essential part of the analysis of carbon balances of wood products [28]. Important temporal aspects of the wood life cycle include dynamics

of forest management, the duration of carbon storage in wood product, and the time dynamics of carbonation cement process reactions. Consideration of forest dynamics at both stand level and landscape level is an essential part of an analysis of the carbon footprint of wood-based building [29].

As part of a dynamic biogeochemical cycle, carbon storage in wood products is an inherently transient phenomenon, though some long-lived wood products may store carbon for centuries. Over the life cycle of a building, there is no change in carbon stock in the building itself. Before the building is built, it contains no carbon stock; and it contains no carbon stock after it is demolished. Combustion of wood-based demolition material ensures that 100% of the carbon stock is oxidised and re-enters the atmosphere as CO₂. If the demolition material is used as biofuel to replace coal, the fossil carbon emissions that are avoided are roughly equivalent to the carbon stored in the wood material during the building lifespan [30]. On a larger scale, a carbon sequestration effect occurs if the total stock of wood products is increasing. This could occur as a result of general economic growth, whereby more products of all kinds are produced and possessed, or through a societal transition from non-wood to wood-based products. If the total stock of carbon in wood products is increasing, carbon storage in products contributes to reducing atmospheric CO₂ concentration. The carbon stock in wood products would increase if a change were made from non-wood to wood-based construction. This would occur if non-wood buildings, representing the baseline, are replaced by wood-framed ones, which after demolition are always replaced by new wood-framed buildings with a similar carbon stock. This would result in a step change in carbon stock compared to the baseline, at the point in time when the non-wood material is replaced by wood. The permanence of the carbon stock in buildings depends on the difference between the amount of wood added to new construction and the amount of wood removed from demolished buildings [31]. The stock of wood products will stabilise if the rate of wood entering the wood products reservoir is equal to the rate at which used wood is oxidised and releases its stored carbon to the atmosphere. At this point, the storage of carbon in wood products has no net effect on the atmospheric CO₂ concentration.

Spatial aspects of wood product systems

Wooden buildings require greater amounts of biomass, and thus a larger forest area, than non-wooden buildings. Gustavsson et al. [32] described three different land-use modelling approaches to address the issue. The first assumes that the incremental wood material is produced through more intensive management of forest land, or from land that was not previously used for wood production. The second assumes that an equal area of land is available to both the wood-frame and concrete-frame buildings, and analyses the carbon balance impacts of biological carbon sequestration on the “surplus forest,” or the part of the land not used for building material production. The last approach assumes that the difference in wood quantity between the wood and concrete buildings is used for energy instead of for construction.

Energy supply systems

The use of fossil fuels produces CO₂ emissions in quantities that depend on the carbon intensity and fuel-cycle characteristics of the fuel. Specific CO₂ emission values are applied to end-use quantities of fossil fuels to give total emissions. To ensure accurate reporting, specific emission values must include emissions occurring over the entire fuel cycle, including the end-use combustion of the fuels as well as from fuel extraction, conversion and distribution [33]. Uncertainties arise in accounting for fossil fuel emissions, due to methodological differences, heterogeneity of fuels, and imprecision in measuring [34]. The marginal effects of changes in fossil fuel use, rather than average effects, should be considered.

There are different electricity production systems, and these are characterized by significant variation in their primary energy use and CO₂ emission. Two different approaches to accounting for primary energy use and CO₂ emission from electricity supply and use are the average and marginal methods. There is much discussion in literature about which method should be employed in an analysis (e.g., [35]). In principle, the method employed should reflect the purpose and relevance of a study. The marginal accounting method may be used because it captures the consequences of changes due to variation in system parameters. The average accounting method is not suitable because changes do not readily reflect

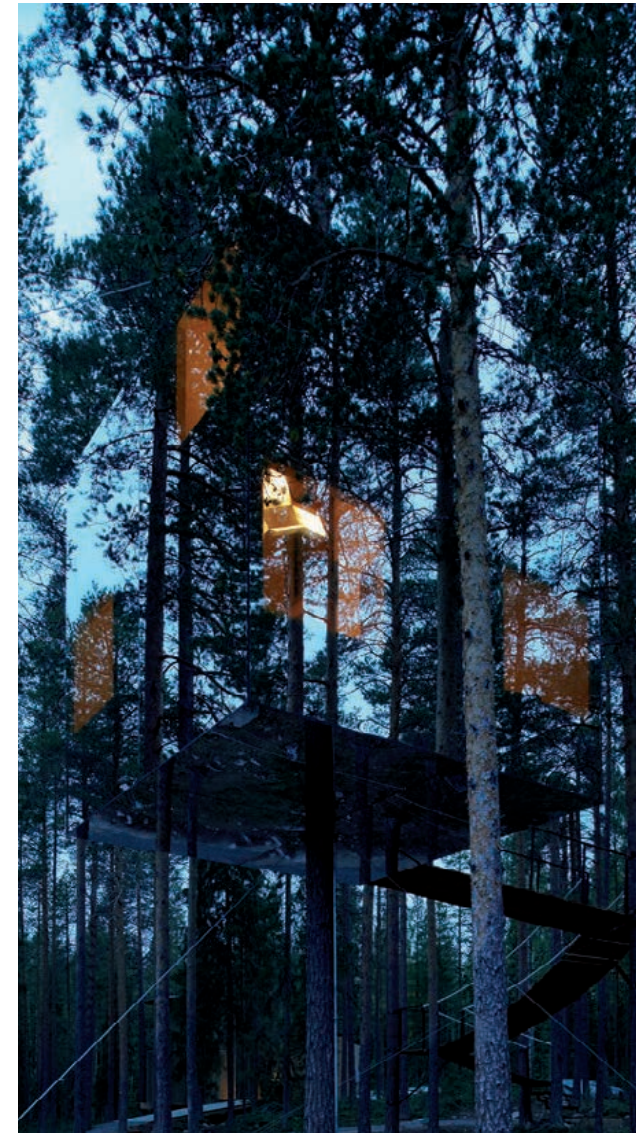

F.4.5-3 Tree hotel, Harads, Sweden

the average level [36]. In addition, this approach does not reflect the technologies and inputs affected by a variation in a system.

The electricity production in the EU in 2006 originated mainly from conventional, thermal plants (54%) and nuclear plants (30%). Hydro (11%) and other renewables (5%) accounted for the remainder (Euroelectric, 2008). Only some 11% of the EU's electricity is produced in combined heat and power (CHP) plants (Eurostat, 2009). The marginal electricity in northern Europe is typically coal-based (STEM, 2002). Fossil gas plants have dominated investments during the past decade, but a number of coal and lignite plants are also under construction and more are planned [37]. Future development will depend on several factors, such as concerns regarding the security of the energy supply and emission restrictions. The supply of fossil gas is considered less secure than the supply of coal. Because the electricity production system may not be known with certainty, it is worthwhile to conduct the analysis with more than one reference electricity production system to determine the significance of this uncertainty.

Allocation in co-products systems

The allocation approach used may have a significant effect on the results of a carbon footprint analysis for co-product systems[38]. Cogeneration systems, or combined heat and power (CHP) systems, produce both heat and electricity. Sawmills can use wood processing residues to cogenerate both process heat for kiln drying, for example, and electricity for use within the mill and for export. Different methods can be used to compare cogeneration and separate heat and electricity production. It is preferable to use a method that avoids allocation because of the subjective nature of allocation ([39], [40]).

Allocation can be avoided if the systems being compared all use the same functional unit. The functional unit is defined based on the products produced by the systems. Therefore, to compare cogeneration systems producing both heat and electricity with systems producing heat or electricity only, both the energy carriers should be considered in the functional unit [41], [42]. (Figure 2). This can be done by expanding the systems by adding an alternative means of producing heat or electricity to systems that produce only one of the energy carriers, thereby making

the systems multi-functional. In a multi-functional method, the functional unit is expanded to include all products produced. When heat and electricity are co-produced, they are both part of the functional unit and either one of them can be considered the main product. Subtracting either heat or electricity production from cogeneration is another way of comparing such systems [43], [44]. In this case, the functional unit will be only electricity or heat. The subtraction is typically based on the avoidance of an assumed electricity or heat production in stand-alone plants using comparable fuels and technologies. The transparency is poorer when using the subtraction method than when using the multi-functional method [45]. In some cases, however, it may be preferable to use this method, for example when analysing the heat at end user, to whom the cogenerated electricity is of no interest [46]. The choice of system expansion method does not affect the primary energy ranking of the heating systems [47].

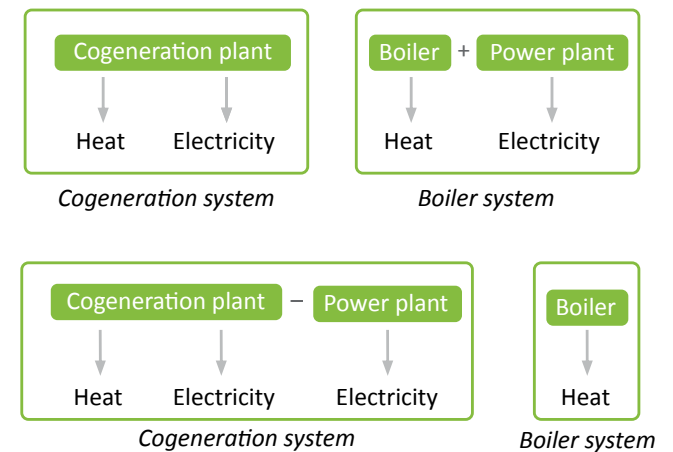

F.4.5-4 An example of system expansion (top) with multi-functional products in the functional unit, and system subtraction (bottom) where cogenerated electricity is subtracted so the functional unit is heat ([48], [49])

- Holistic analysis of carbon footprint of wood versus nonwood based building systems is a complex issue.
- Full lifecycle and energy chains should be considered to optimize the carbon footprint of buildings.
- System boundaries should be broad enough to include all significant impacts.
- Allocation should be avoided if possible, e.g. by system expansion.

4.5.3 Simple system boundary for practical implementation

A. Hafner, A. Takano, S. Winter, S. Ott

This section focuses on the basic methodologies for the simplified system, from wider aspects described in Section 4.4.2. The points related to the system buildings: all inputs and outputs related to the system, system boundaries, allocations and cut-of-criteria, are described concisely. This approach aims at describing environmental profile of a building in its life cycle. As a building process is a complex issue, system boundaries get limited. Due to the interactions of different issues, borders are drawn with the awareness that some issues are being left outside the system.

Scope and goal

The scope of calculation is the system building. Due to complex interactions of different issues in the building context (energy standard, fire regulation, sound protection, building services, material choice, detailing, and national building regulations and standards), reasonable borders are recommendable as a starting point.

The whole life cycle process should be considered, and all direct influences from the system building should be included. EN 15978 defines the following life cycle stages:

- Product stage (module A1-3)
- Construction stage (module A4-5)
- Use stage (module B)
- End-of-Life stage (module C)

In addition to that, the environmental burden and benefit over each life cycle phase can be described in module D for the studied system. Figure F.4.5-6 shows the complete life cycle of the system building, from material extraction to end-of-life of a building.

System boundaries

A clear statement is needed in order to specify which building elements and building life cycle stages are included in the studied



F.4.5-5

F.4.5-6

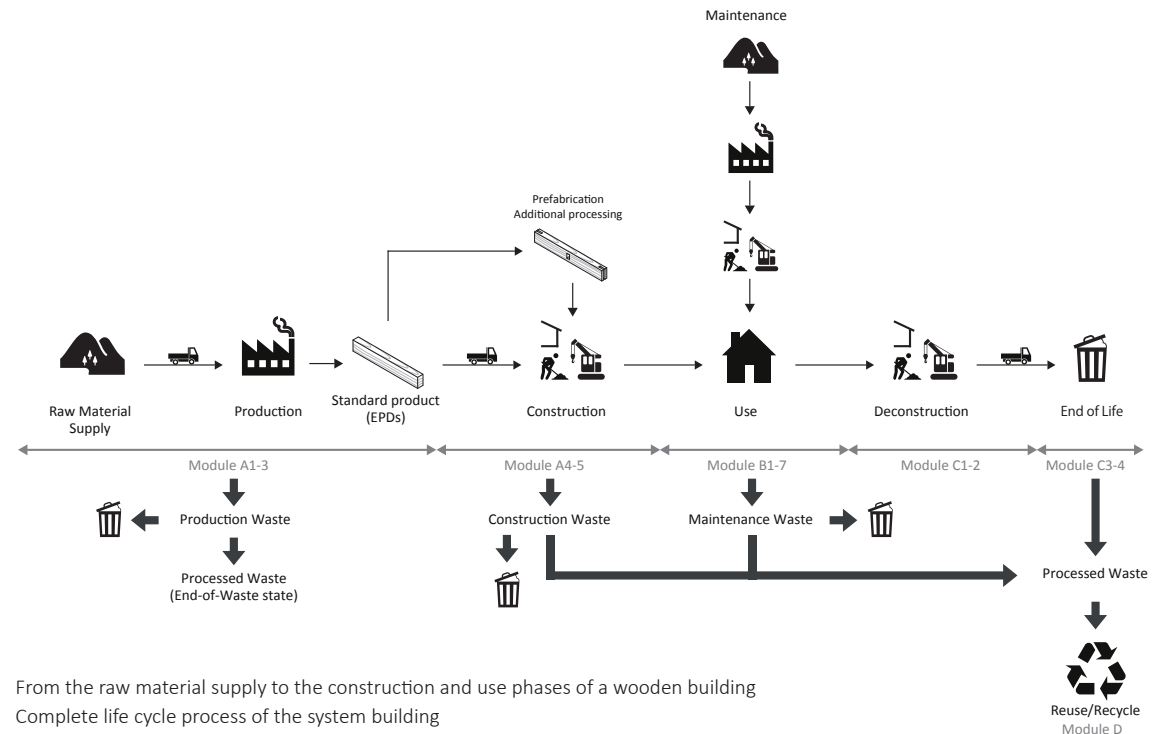

F.4.5-5 From the raw material supply to the construction and use phases of a wooden building

F.4.5-6 Complete life cycle process of the system building

system. Figure F.4.5-7 is an example of a clear indication of the system boundary. Chapter 8 – Case studies also provides an example of such an indication. As shown in figure 4.4-8, visualization can help clarify the system boundary regarding building parts.

Service life

The service life affects the use phase of the studied building. Operation energy and maintenance frequency varies depending on the defined service life. Fifty years would be relevant as the service life of a studied system building for practical LCA. This is used for the examples calculated in Chapter 6. For maintenance and replacement of building parts, appropriate RSL needs to be defined..

Functional unit

“Functional unit provides a reference to which the input and output data are normalized.” [50]. For buildings, the reasonable functional units are the following: entire building, per m² of gross floor area/ net floor area / living floor area, and m² of the building element according to the purpose of the study. A clear definition of different floor area calculations is important. Figure 4.4-6 shows the definition used in this book. Gross floor area is an area of the house along the outside of a wall; exterior space (e.g. a balcony) is not included. Net floor area is an area along the inside of the walls. Living floor area is an area along the inside of the walls excluding technical space and maintenance space (e.g. machine room and storage space). Living floor area is used in the case studies of this book in order to compare different reference buildings on the same basis.

Cut-off criteria

Not all inputs have relevant influence on calculation results. To make calculation easier, cut-off criteria can be defined. They have to be described clearly in the reports. According to EN15804, in principle all input and output shall be included in the calculation. But it also states that “In case of insufficient input data or data gaps for a unit process, the cut-off criteria shall be 1% of renewable and non-renewable primary energy usage and 1% of the total mass input of that unit process.”

The total of neglected input flows per module, e.g. per module A1-A3, A4-A5, B1-B5, B6-B7, C1-C4 and module D (see Figure 1), shall be a maximum of 5% of energy usage and mass. Conservative assumptions in combination with plausibility considerations and expert judgement can be used to demonstrate compliance with these criteria.

LCA data source

There are several LCA data types: generic data, average data, and product specific data. Type and quality of data, such as age of data source, calculation method and allocations, related standards, etc., need to be shown clearly. There are various data sources available in Europe. They vary significantly due to different purposes, methodologies, data collection methods, etc. New calculations done according to standard EN 15804 cannot be easily compared to old data without close inspection of the content.

At the beginning of the design stage, generic/ average data is recommendable to get an overall picture. For calculations in later stages of the building process, specific data from producers

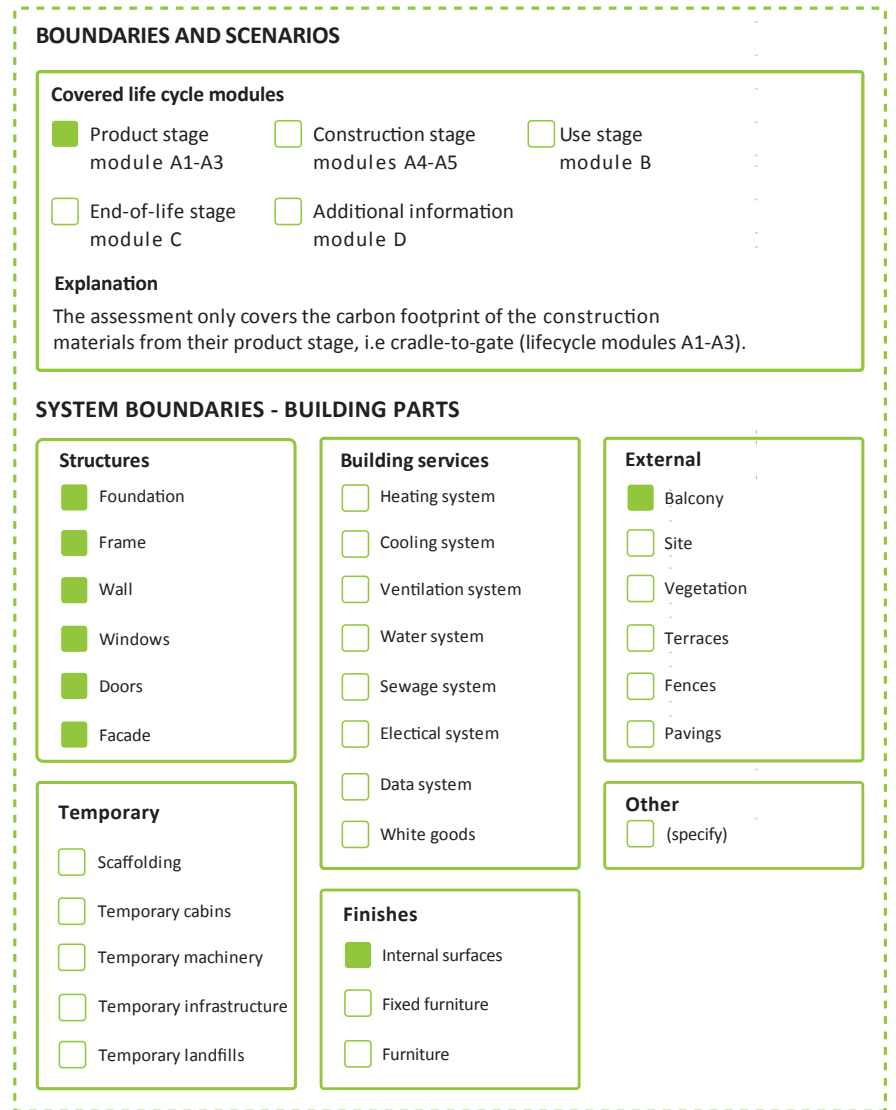

F.4.5-7 Example of a list to describe life cycle stages and building parts included in an LCA study.

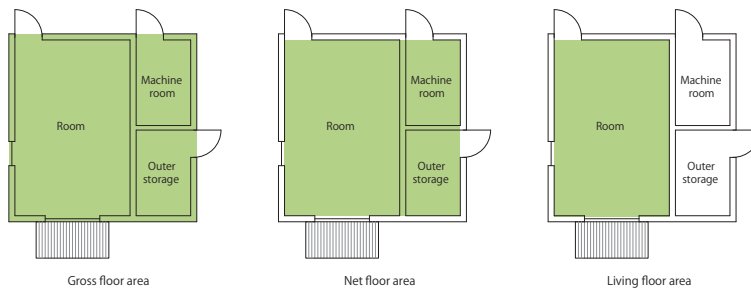
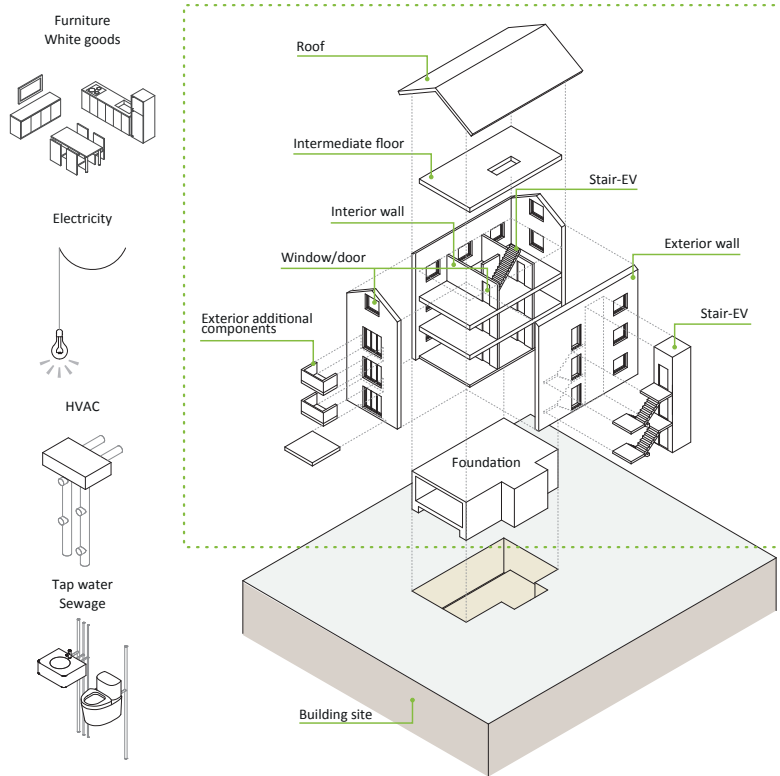

F.4.5-8 Example for visualization of included building elements

F.4.5-9 Different types of floor areas

are relevant to show the status as-built. An Environmental Product Declaration (EPD) is the most relevant data as specific data for the calculation.

Allocation

Allocation should be done according to physical flows where it cannot be avoided. The allocation issue regarding the production stage of building materials is described in Section 4.3. After the production stage, allocation of consumed energy during the construction stage (A5) needs to be taken into consideration. In many cases, several construction works are running at the same time in both the prefabrication factory and the construction site. In order to allocate consumed energy to each production line or construction work, the physical amount could be used.

Basically it is difficult to collect the data from the construction stage due to the lack of resources and time. Therefore, a simple method is required without missing certain reliability. For instance, the allocation of space heating energy for a building in a prefabrication factory could be done based on the floor area of all buildings in the factory as considering the setting of temperature. Electricity consumption for the operation of prefabrication or on-site construction could be allocated based on the production volume of a factory or the duration of each work from the monthly electricity consumption. Although available information would be case by case, the use of some physical basis is recommended.

Interpretation of results

The interpretation is closely linked to the scope of the life cycle analysis. For instance, the outcome shall show:

- environmental impact and benefit according to the life cycle phases (module A to C and D);
- environmental impact and benefit according to the building elements in order to understand the influence of specific parts;

- variations/scenarios on the same building with different construction systems, building service systems, etc., in decision-making; and
- material and mass distribution.

Reporting of the result is required to be as clear, understandable, and transparent as possible. All related carbon flow in the system needs to be described. In order to avoid misreading, the contents of the impacts and benefits shall be documented separately according to the scope and purpose of the study. For instance, GHG emission from fossil fuel and biogenic fuel or carbon and energy storage capacity in the building components should be displayed individually. A basic conclusion and recommendation shall be shown based on the findings and objectives of the study.

4.6 Conclusions

This chapter introduces the international normative standards related to carbon footprints and gives information regarding the tools and databases for calculating the carbon footprint an entire building. In addition, methodological issues, specifically those for assessing wood products and buildings, are discussed in detail.

To assess the carbon footprint of a building, the following information is required: the quantities and qualities of the building materials, the environmental impacts of products, the energy demand of the building and the energy supply systems and their environmental impact. In addition, the service life of building components and elements need to be taken into account based on the particular situation. Nowadays, many databases and tools are available for such calculations. Relevant data should be used in the calculations as much as possible. In principle, the use of specific LCA data is recommended, but generic (average) data is relevant in the early assessment phases. There are significant variations in different databases. The variations may be caused by actual differences in the production processes, energy supply solutions and the applied methodology, such as the system boundaries. The system boundaries and principles used in the calculation could significantly influence the assessment results for wood products. In particular, the consideration of sequestered carbon

and biogenic CO₂ has a major effect on the results. Therefore, a clear description of the assessment assumptions and results is a fundamental requirement.

In principle, scope and goal of the assessment is dependent on the purpose. Thus, the most relevant methodology is applied on a case-by-case basis, and it would be impossible to strictly standardize the methodology. However, it makes it so that results of the assessment cannot be compared, which is a significant issue when it comes to the practical implementation of carbon footprint calculations. Allocating the environmental impact in a multi-output process has been one of the main issues when assessing wood products. The manufacturing process for wood products generates several co-products. In principle, the allocation method is selected on a case-dependent basis. Allocation is a subjective procedure and the ISO 14044 indicates that it should be avoided whenever possible. In case allocation cannot be avoided, physical mass allocation is recommended for the assessment of wood products as a default methodology. The environmental impact, which is a physical phenomenon, should not be affected by a fluctuating social and economic situation.

The carbon footprint analysis of buildings is more complex than that of many other products. A wood-based system in particular is rather complicated. The analysis should take into account all the inputs and outputs over time across every stage of processing, from forest regeneration and management to harvesting, product processing, product use, maintenance and the final disposal of the wood in order to understand the full carbon flow connected to a building. The entire life cycle and energy chain should be considered with broad enough system boundaries to include all significant impacts. On the other hand, a practical simplification of the system may be required, for instance when the purpose is to assess the building system itself. We propose that a simplified system boundary should only include the direct environmental effect of a building. A simple and accurate system is a good starting point for a practical implementation of the carbon footprint analysis.



F.4.5-10 Installation of a TES-element, Finland

- For a description of environmental properties of a building in practical use, a simplified system boundary is applicable, shown as a red line in Figure F.4.5-1.
- A transparent description of system boundaries, cut-off criteria, service life, data sources and allocation is needed.

4.1 Introduction

- [1] Greenhouse Gas Protocol - Product Life Cycle Accounting and Reporting Standard. World Resources Institute – WBCSD.

4.2 Standards related to carbon footprint

- [1] European Commission, 2013. Product environmental footprint (PEF) news. [online] Available at: <http://ec.europa.eu/environment/eusssd/product_footprint.htm> [Accessed 12 June 2013].

4.3 Assessment procedure and assessment tools and their use

- [1] Institut Bauen und Umwelt e.V. Environmental product declarations (EPD). [online] Available at: <<http://bau-umwelt.de/hp481/Environmental-Product-Declarations-EPD.htm>> [Accessed 12 June 2013].
- [2] INIES. Consulter les Fiches de Déclaration Environnementale et Sanitaire (FDES) des Produits de construction. [online] Available at: <<http://www.inies.fr/IniesConsultation.aspx>> [Accessed 12 June 2013].
- [3] VTT. ILMARI-arviointipalvelu. [online] Available at: <<http://www.vtt.fi/sites/ilmari/index.jsp>> [Accessed 12 June 2013].
- [4] European Commission. ELCD. [online] Available at: <<http://lca.jrc.ec.europa.eu/lcainfohub/datasetArea.vm>> [Accessed 12 June 2013].
- [5] European Commission. ELCD. [online] Available at: <<http://lca.jrc.ec.europa.eu/lcainfohub/datasetArea.vm>> [Accessed 12 June 2013].

- [6] European Commission. Database GEMIS 4.. [online] Available at: <<http://lca.jrc.ec.europa.eu/lcainfohub/database2.vm?dbid=129>> [Accessed 12 June 2013].

- [7] GaBi software. GaBi LCA databases. [online] Available at: <<http://www.gabi-software.com/databases/gabi-databases/>> [Accessed 12 June 2013].

- [8] Ecoinvent Center. The ecoinvent databse. [online] Available at: <<http://www.ecoinvent.org/database/>> [Accessed 12 June 2013].

- [9] IPCC, 2006. Guidelines for National Greenhouse Gas Inventories, 2. [online] Available at: <<http://www.ipcc-nggip.iges.or.jp/public/2006gl/vol2.html>> [Accessed 12 June 2013], chapter 1-3.

- [10] European Commission. ELCD. [online] Available at: <<http://lca.jrc.ec.europa.eu/lcainfohub/datasetArea.vm>> [Accessed 12 June 2013].

- [11] IEA. Statistics & Balances. [online] Available at: <<http://www.iea.org/stats/index.asp>> [Accessed 12 June 2013].

- [12] Häkkinen, T., Ruuska A., Vares,S, Pulakka S., Kouhia,I. and Holopainen, R., 2012. Methods and concepts for sustainable renovation [Kestävän korjausrakentamisen menetelmät]. Espoo: VTT Technology.

- [13] prEN 16485, round wood and sawn timber – environmental product declarations – product category rules for wood and wood-based products for use in construction

- [14] Mattila, T., Helin, T., Antikainen, R., Soimakallio, S., Pingoud, K. and Wessman, H., 2011. Land use in life cycle assessment. The Finnish Environment, 24.

- [15] Repo, A., Tuomi, M. and Liski, J., 2010. Indirect carbon oxide emissions from producing bioenergy from forest harvest residues. GCB Bioenergy 3(2).

- [16] Häkkinen, T. and Belloni, K., 2011. Barriers and drivers for sustainable building. Building Research & Information, 39(3), pp.239-255.

- [17] Fies, B. 2011. SuPerBuildings D3.3. Needs, levels and potentials of integrating SB assessment and benchmarking with BIMs.

- [18] Ruuska, A. and Häkkinen, T., 2011. House Jokilehto. Calculation of environmental impacts for House Jokilehto and two alternative scenarios with Log House Calculator 2011-tool.

- [19] Superbuildings. Sustainability and performance assessment and benchmarking of buildings. [online] Available at: <<http://cic.vtt.fi/superbuildings/>> [Accessed 12 June 2013].

- [20] Häkkinen, T. ed., 2012. Sustainability and performance assessment and benchmarking of building – Final report. Espoo: VTT Technology. [online] Available at: <<http://www.vtt.fi/inf/pdf/technology/2012/T72.pdf>> [Accessed 12 June 2013].

- [21] Fies, B. 2012. SuPerBuildings D6.3 Recommendations for the integration of sustainable building assessment and benchmarking methods with BIMs.

- [22] Ruuska, A. and Häkkinen, T., 2012. The significance of different factors on GHG emissions of buildings. [pdf] Available at: <<http://cic.vtt.fi/superbuildings/sites/default/files/03.pdf>> [Accessed 12 June 2013].

- [23] see also Vares, S. and Häkkinen, T., 2011. Sustainability and LCA assessment for a passive house kindergarten. Proceedings

of SB11 Helsinki World Sustainable Building Conference, 2, pp. 436-437, full papers pp. 686-693.

[24] IPCC, 2007. TS.2.5 Net Global Radiative Forcing, Global Warming Potentials and Patterns of Forcing. [online] Available at: <http://www.ipcc.ch/publications_and_data/ar4/wg1/en/tssts-2-5.html> [Accessed 12 June 2013]

[25] Häkkinen, T., Ruuska A., Vares.S, Pulakka S., Kouhia,I. and Holopainen, R., 2012. Methods and concepts for sustainable renovation [Kestävän korjausrakentamisen menetelmät]. Espoo: VTT Technology.

4.4 Product level

- [1] European Commission's Joint Research Centre Institute for Environment and Sustainability, 2010. ILCD Handbook: General Guide for Life Cycle Assessment – Provisions and action steps.
- [2] ISO 14044 Environmental management – Life cycle assessment – Requirements and guidelines.
- [3] ISO 14040 Environmental management – Life cycle assessment – Principles and framework.
- [4] EN 15804 Sustainability of construction works – Environmental product declarations – Core rules for the product category of construction products.
- [5] Ecoinvent Centre, 2007. Life cycle inventories of wood as fuel and construction materials. Data v2.0, Dübendorf.
- [6] EN 15942 Sustainability of construction works – Environmental product declarations – Communication format business-to-business.
- [7] Baumann, H. and Tillman, A.-M., 2004. The Hitch Hiker's Guide to LCA. Studentlitteratur.

[8] European Commission's Joint Research Centre Institute for Environment and Sustainability, 2010. ILCD Handbook: General Guide for Life Cycle Assessment – Provisions and action steps.

[9] ISO 14044 Environmental management – Life cycle assessment – Requirements and guidelines.

4.5 Building level

- [1] Kotaji, S., Schuurmans, A. and Edwards, S., 2003. Life-Cycle Assessment in Building and Construction: A State-of-the-art Report. Pensacola FL, USA: SETAC Press.
- [2] ISO/TS 14067:2013 Greenhouse gases - Carbon Footprint of Products – Requirements and guidelines for quantification and communication. International Organization for Standardization.
- [3] Gustavsson, L. and Sathre, R., 2011. Energy and CO2 analysis of wood substitution in construction. *Climatic Change*, 105(1 2), pp.129-153.
- [4] Gustavsson, L. and Sathre, R., 2011. Energy and CO2 analysis of wood substitution in construction. *Climatic Change*, 105(1 2), pp.129-153.
- [5] EN 15978. Sustainability of construction works: Assessment of environmental performance of buildings – Calculation method. Draft submitted to Formal Vote Ballot, 16.05.2011
- [6] Schlamadinger, B., Apps, M., Bohlin, F., Gustavsson, L., Jungmeier, G., Marland, G., Pingoud, K. and Savolainen, I., 1997. Towards a standard methodology for greenhouse gas balances of bioenergy systems in comparison with fossil energy systems. *Biomass and Bioenergy*, 13(6), pp.359-375.
- [7] Sathre, R., 2007. Life-cycle energy and carbon implications of wood-based products and construction. PhD. Mid Sweden University.

[8] Björklund, T. and Tillman, A.-M., 1997. LCA of Building Frame Structures: Environmental Impact over the Life Cycle of Wooden and Concrete Frames. Technical Environmental Planning Report 1997:2. Chalmers University of Technology, Sweden.

[9] Dadoo, A., Gustavsson, L. and Sathre, R., 2009. Carbon implications of end-of-life management of building materials. *Resources, Conservation and Recycling*, 53(5), pp.276-286.

[10] Gustavsson, L. and Sathre, R., 2006. Variability in energy and carbon dioxide balances of wood and concrete building materials. *Building and Environment*, 41(7), pp.940-951.

[11] ISO/TS 14067:2013 Greenhouse gases - Carbon Footprint of Products – Requirements and guidelines for quantification and communication. International Organization for Standardization.

[12] Adalberth, K., 2000. Energy Use and Environmental Impact of New Residential Buildings. Ph.D. Lund University of Technology.

[13] Gustavsson, L., Joelsson, A. and Sathre, R., 2010. Life cycle primary energy use and carbon emission of an eight-story wood-framed apartment building. *Energy and Buildings*, 42(2), pp.230-242.

[14] Gustavsson, L., Pingoud, K. and Sathre, R., 2006. Carbon dioxide balance of wood substitution: comparing concrete- and wood-framed buildings. *Mitigation and Adaptation Strategies for Global Change*, 11(3), pp. 667-691.

[15] Sathre, R., 2007. Life-cycle energy and carbon implications of wood-based products and construction. PhD. Mid Sweden University.

[16] Nässén, J., Holmberg, J., Wadeskog, A. and Nyman, M., 2007. Direct and indirect energy use and carbon emissions in the production phase of buildings: An input-output analysis. *Energy*, 32, pp.1593-1602.

- [17] Balaras, C.A., 1996. The role of thermal mass on the cooling load of buildings: an overview of computational methods. *Energy and Buildings*, 24(1), pp. 1-10.
- [18] Strusoft, 2010. Overview of VIP-Energy. [online] Available at: <www.strusoft.com> [Accessed 13 June 2011].
- [19] Gustavsson, L. and Joelsson, A., 2007. Energy conservation and conversion of electrical heating systems in detached houses. *Energy and Buildings*, 39(6), pp. 716-726.
- [20] Joelsson, A. and Gustavsson, L., 2009. District heating and energy efficiency in detached houses of differing size and construction. *Applied Energy*, 86, pp.126-134.
- [21] Harvey, L.D.D., 2009. Reducing energy use in the buildings sector: measures, costs, and examples. *Energy Efficiency*, 2 (2), pp. 139-163.
- [22] ISO/TS 14067:2013 Greenhouse gases - Carbon Footprint of Products – Requirements and guidelines for quantification and communication. International Organization for Standardization.
- [23] Sathre, R and O'Connor, J., 2010. Meta-analysis of greenhouse gas displacement factors of wood product substitution. *Environmental Science and Policy*, 13(2), pp. 104-114.
- [24] Gustavsson, L., Joelsson, A. and Sathre, R., 2010. Life cycle primary energy use and carbon emission of an eight-story wood-framed apartment building. *Energy and Buildings*, 42(2), pp.230-242.
- [25] European Commission, 2001. Task Group 3: Construction and demolition waste. Final report of the construction and demolition waste working group, [online] Available at: <http://ec.europa.eu> [Accessed 28 March 2008].
- [26] Gustavsson, L. and Sathre, R., 2006. Variability in energy and carbon dioxide balances of wood and concrete building materials. *Building and Environment*, 41(7), pp.940-951.
- [27] Dadoo, A., Gustavsson, L. and Sathre, R., 2009. Carbon implications of end-of-life management of building materials. *Resources, Conservation and Recycling*, 53(5), pp.276-286.
- [28] Lippke, B., Oneil, E., Harrison, R., Skog, K., Gustavsson, L. and Sathre, R., 2011. Life cycle impacts of forest management and wood utilization on carbon mitigation: Knowns and unknowns. *Carbon Management*, 2(3), pp.303-333.
- [29] Lippke, B., Oneil, E., Harrison, R., Skog, K., Gustavsson, L. and Sathre, R., 2011. Life cycle impacts of forest management and wood utilization on carbon mitigation: Knowns and unknowns. *Carbon Management*, 2(3), pp.303-333.
- [30] Gustavsson, L., Pingoud, K. and Sathre, R., 2006. Carbon dioxide balance of wood substitution: comparing concrete- and wood-framed buildings. *Mitigation and Adaptation Strategies for Global Change*, 11(3), pp. 667-691.
- [31] Lippke, B., Oneil, E., Harrison, R., Skog, K., Gustavsson, L. and Sathre, R., 2011. Life cycle impacts of forest management and wood utilization on carbon mitigation: Knowns and unknowns. *Carbon Management*, 2(3), pp.303-333.
- [32] Gustavsson, L., Pingoud, K. and Sathre, R., 2006. Carbon dioxide balance of wood substitution: comparing concrete- and wood-framed buildings. *Mitigation and Adaptation Strategies for Global Change*, 11(3), pp. 667-691.
- [33] Gustavsson, L., Pingoud, K. and Sathre, R., 2006. Carbon dioxide balance of wood substitution: comparing concrete- and wood-framed buildings. *Mitigation and Adaptation Strategies for Global Change*, 11(3), pp. 667-691.
- [34] Marland, G., 2008. Uncertainties in accounting for CO2 from fossil fuels. *Journal of Industrial Ecology*, 12(2), pp. 136-139.,
- [35] Sjödin, J. and Grönkvist, S., 2004. Emissions accounting for use and supply of electricity in the Nordic market. *Energy Policy*, 32(13), pp. 1555-1564.
- [36] Hawkes, A.D., 2010. Estimating marginal CO2 emissions rates for national electricity systems. *Energy Policy*, 38(10), pp.5977-5987.
- [37] Kjärstad, J., Johnsson, F., 2007. The European power plant infrastructure: Presentation of the Chalmers energy infrastructure database with applications. *Energy Policy*, 35(7), pp.3643-3664.
- [38] Joelsson, A. and Gustavsson, L., 2009. District heating and energy efficiency in detached houses of differing size and construction. *Applied Energy*, 86, pp.126-134.
- [39] Schlamadinger, B., Apps, M., Bohlin, F., Gustavsson, L., Jungmeier, G., Marland, G., Pingoud, K. and Savolainen, I., 1997. Towards a standard methodology for greenhouse gas balances of bioenergy systems in comparison with fossil energy systems. *Biomass and Bioenergy*, 13(6), pp.359-375.
- [40] ISO 14044: Environmental Management – Life Cycle Assessment – Requirements and Guidelines. International Organization for Standardization.
- [41] Finnveden, G. and Ekvall, T., 1998. Life-cycle assessment as a decision-support tool: the case of recycling versus incineration of paper. *Resources, Conservation and Recycling*, 24, pp.235-256.
- [42] Gustavsson, L. and Karlsson, Å., 2006. CO2 mitigation: On methods and parameters for comparison of fossil-fuel and biofuel systems. *Mitigation and Adaptation Strategies for Global Change*, 11(5-6), pp.935-959.
- [43] Finnveden, G. and Ekvall, T., 1998. Life-cycle assessment as a decision-support tool: the case of recycling versus incineration of paper. *Resources, Conservation and Recycling*, 24, pp.235-256.
- [44] Gustavsson, L. and Karlsson, Å., 2006. CO2 mitigation: On methods and parameters for comparison of fossil-fuel and

biofuel systems. *Mitigation and Adaptation Strategies for Global Change*, 11(5-6), pp.935-959.

- [45] Finnveden, G. and Ekvall, T., 1998. Life-cycle assessment as a decision-support tool: the case of recycling versus incineration of paper. *Resources, Conservation and Recycling*, 24 , pp.235-256.
- [46] Karlsson, Å. and Gustavsson, L., 2003. External costs and taxes in heat supply systems. *Energy Policy*, 31, pp.1541-1560.
- [47] Joelsson, A. and Gustavsson, L., 2009. District heating and energy efficiency in detached houses of differing size and construction. *Applied Energy*, 86, p.126-134.
- [48] Finnveden, G. and Ekvall, T., 1998. Life-cycle assessment as a decision-support tool: the case of recycling versus incineration of paper. *Resources, Conservation and Recycling*, 24 , pp.235-256.
- [49] Gustavsson, L. and Karlsson, Å., 2006. CO2 mitigation: On methods and parameters for comparison of fossil-fuel and biofuel systems. *Mitigation and Adaptation Strategies for Global Change*, 11(5-6), pp.935-959.
- [50] EN ISO 14044- 2006: Environmental management – Life cycle assessment – Requirements and guidelines, p.17.



F.4.6 Gothenburg University, Sweden



5. Environmental aspects of raw material supply and manufacturing

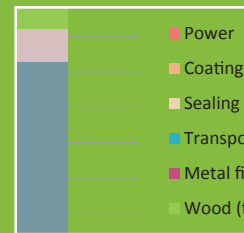
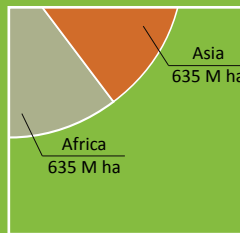

62

5.1 Introduction

62

5.2 Raw material supply

64

5.3 Sawn timber manufacturing and carbon footprint

66

5.4 Optimisation and development aspects of current manufacturing processes

67

5.5 Conclusions

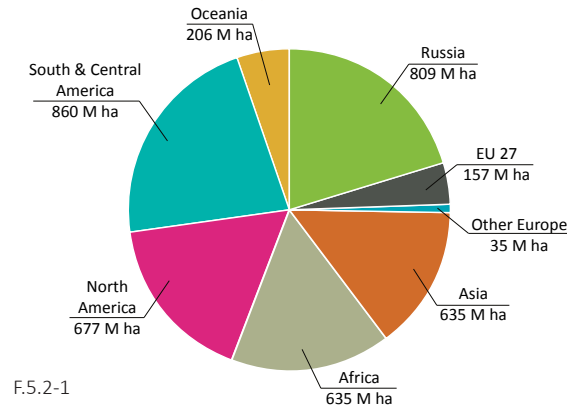

F.5.2-1

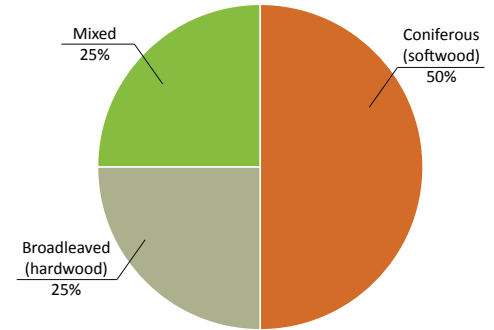

F.5.2-2

F.5.2-3

5.1 Introduction

T. Häkkinen

The objective of this chapter is to discuss the aspects of life cycle assessment on product level, considering the extraction of raw materials, transportation and manufacturing. Instead of dealing with the issue from the general point of view, the chapter focuses on the environmental assessment of sawn timber and some other wood-based product.

The section gives information about the raw material supply, environmental impacts of harvesting and manufacture, and discusses the impact of different factors on the carbon footprint of sawn timber and the possibilities to improve.

The target of the section is to provide an example of product-level LCIs in order to cover the full value chain in this book instead of focusing only on building-level assessments.

This chapter also points out that the principal purpose of the LCA methodology is to provide a tool for eco-design and life cycle management. The LCA method is most powerful when the product developers and designers use it as a tool that supports—

not just a comparison of available products or buildings – but the development of new and improved eco-efficient solutions.

5.2 Raw material supply

F. Dolezal, H. Mötzl

The global context of European forests

Globally, forests are an immense resource, accounting for 29.6% of the Earth's total land base. Although European forests, excluding Russia, account for just 5% of that area, they are the most intensively managed in the world, providing 12% of current global round wood fellings and 23% of industrial round wood [1]. The global forest cover is shown in Figure F.5.2-1.

The European forest sector's output is about 25% of current world industrial production of forest products, accounting for almost 30% of wood-based panels, paper and paperboard [2].

Forest types, coverage and felling

85% of Europe's forest cover is semi-natural (some human intervention, but generally natural characteristics), while only



F.5.2-1 Global forest cover by continent [2]

F.5.2-2 The composition of EU 27 forests [3]

F.5.2-3 Wood harvest, Austria

8% is plantation forest, mainly to be found in northwest Europe. In addition, about 5% of the forest area is undisturbed forests, untouched by man, which can be found in East Europe and the Nordic/Baltic areas [3]. Figure F.5.2-2 shows the composition of European forests.

Considering felling per capita, with a 2.0 bank meter, Austria is ranking high above EU-27 amounts and the world (0.8 and 0.6, respectively), but far below Scandinavia with a 6.7 bank meter. In absolute figures, Austria's wood harvest accounted for approximately 4% of EU-27 felling and approximately 0.5% of the world's felling in the year 2005. The share of softwood, with 84%, is comparatively high in Austria compared to EU-27 with 74% and the world with 37% [4].

Different circumstances in European forests – north-middle-south

Beside climatic differences between Northern, Central and Southern Europe with an effect on forest species, even topographic differences are important. Not only forest species are affected by topography, but also logging and forwarding methods with regard to the achieved return.

Since swathes of Central Europe are covered with mountains, harvesting is more complicated, and therefore manual labour still covers a huge part, not just in logging, but also in bringing. For example, in Austria, only 20% of logging is carried out by harvesters [5], 80% is done by using chain saws and in this case bringing methods are mainly cable winch or cable pulls.

North – Sweden

Sweden is a forest country. Two-thirds of the total land area is covered with forests, and half of its net national income comes from the export of forest products. Everyone has common access to the forest; forests are important for recreation and they are dominant in

the Swedish landscape. The forests are fairly uniform in composition. The main species are Norway spruce (*Picea abies*) (46%), Scots pine (*Pinus silvestris*) (37%), and various deciduous species (15%). [6]

Middle – Austria

Forests cover about 47% of Austria's territory (3.9 million hectares). They provide important economic, environmental and socio-cultural benefits, from timber production to protective and recreational functions, which directly or indirectly benefit the whole population. In the mountainous areas (the western two-thirds of the country is alpine), forests have an important role in protection against landslides and avalanches. The forest area has shown a slightly increasing trend in recent decades as a result of natural extension onto agricultural land and afforestation in protected areas. Virtually all forest is considered semi-natural; there are small areas of undisturbed forest. Coniferous species (primarily Norway spruce, Scots pine, European larch and silver fir) make up more than four-fifths of the growing stock. Beech is the main broadleaf species. [6]

South – Spain

With 14.4 million hectares of forest cover, Spain is the fourth country in Europe in terms of forest resources (following Sweden, Finland and France, but excluding the Russian Federation). Forests, which occupy almost 29% of the country's total land area, are increasing by about 86,000 ha per year, both through natural expansion and through the forest plantation programme that has been under way for more than 50 years, with soil protection and erosion prevention as its main aims. The most productive forests are found in the Atlantic coastal zone and are composed mostly of pines (*Pinus pinaster* and *P. radiata*) and eucalyptus (*Eucalyptus globulus*), although some mixed natural forests of oak (*Quercus robur* and *Q. patraea*) and beech (*Fagus sylvatica*) are still found.



F.5.2-4

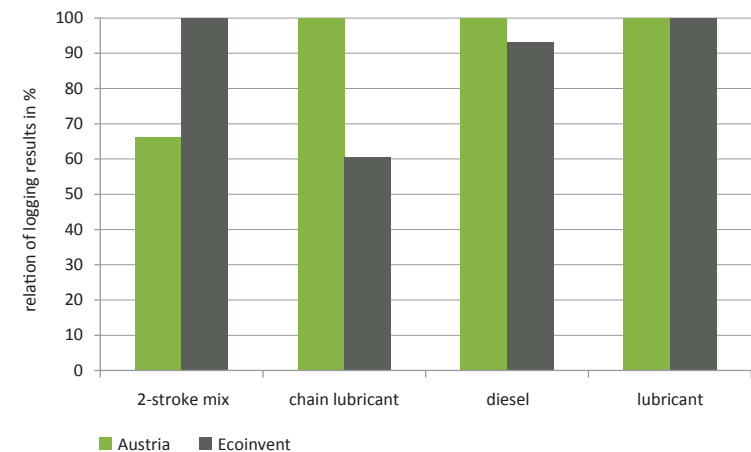

F.5.2-5

F.5.2-4 Timber planks on the sawmill machinery, Sweden

F.5.2-5 Wood harvest comparison of data HFA-Ecoinvent in percent



In the Pyrenees, there are forests of silver fir (*Abies alba*), beech and pine, depending on altitude. [6]

Austrian investigation to logging data

Since data for wood harvesting seemed to have a relevant impact on LCA results, an investigation into logging in Austria was carried out and results were compared to data of the widely used database Ecoinvent data v2.2 [7]. Therefore, energy consumption measurements were carried out in the forest during harvesting procedure and results, referred to the quantity of harvested wood, compared to Ecoinvent data in Figure F.5.2-3.

Measurements were carried out in lower Austria in a gently inclined (15%) terrain with an estimated harvest of 40 bank meters per hectare. The felled species was Scots pine with a length from 15 to 18 m and a diameter between 18 and 25 cm planned as raw material for the pulp industry. Since it was the second harvest (the third would be the last), no clear cutting was carried out.

Felling devices:

1. Harvester type Valmet 901,2
2. Chain saw type Husqvarna 365 SP 3,40 kW/4.60 HP

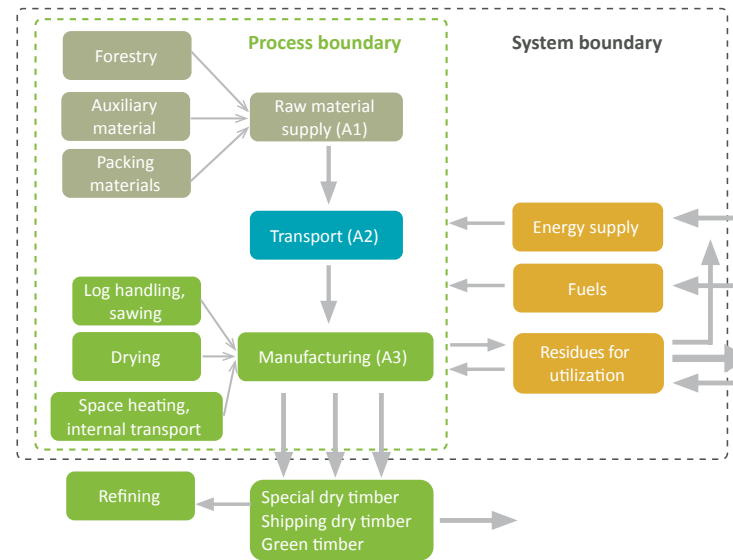

F.5.3-1
F.5.3-2

F.5.3-1 Timber planks are naturally air-dried, Austria
F.5.3-2 System boundary of studied system

Time, energy consumption and quantity of wood were measured when 30 trees were felled in parallel by each device. Quantity was measured automatically by the harvester and manually if a chain saw was used.

Results of the comparison show similar dimensions. Differences can be found in the consumption of the 2-stroke mix and diesel. Whilst Ecoinvent only calculates with chain-saw felling, in Austria approximately 20% of the stems are cut by harvesters. This leads to lower 2-stroke mix results, but higher chain lubricant and diesel consumption for felling and forwarding.

5.3 Sawn timber manufacturing and carbon footprint

S. Vares

General [8, 9]

Sawn timber is a product for various construction applications. Timber can be graded and further processed into I-beams and Scaffold boards, finger-jointed solid construction timber (KVH), and various lamellas for glue-laminated products. Timber production is the largest industry branch within the wood product industry, and because of that, it is extremely important how accurately and comprehensively the inventory of the timber production processes

is done for a good quality environmental impact assessment. Overlooking some processes and generalizations between mills and by products might lead to an inaccuracy in timber calculations, which would also have an effect on the results of the refined products.

LCA and carbon footprint

LCA addresses the environmental aspects and potential environmental impacts throughout a product's life cycle (i.e. cradle-to-grave [10]). Carbon footprint is the overall amount of fossil-based carbon dioxide (CO₂) and other greenhouse gas (GHG) emissions (e.g. methane, laughing gas, etc.) associated with a product along its supply chain.

Wooden products have to be dealt with by specific methodological approaches, which also affect the results. Important issues that have a significant effect on the final result include consideration of carbon sequestration, allocation of impacts to product and by-products, consideration of release of GHGs in final disposal and recycling, and consideration of consequential effects. Because of those complicated issues, the assessment can give very different results, which is also seen in the literature. One issue is emphasized here: the product level assessment should be based on an attributional analysis to avoid double counting.

The methodology and assessment results presented here cover the timber process from the 'cradle-to-gate' phase (A1, A2, A3) [11] and aspects related to the carbon footprint assessment (Figure F.5.3-2).

Material efficiency and by-products

Timber production generates not only timber but also valuable raw materials for the chipboard, energy and pulp industry (Figure F.5.3-3). The wooden material waste could be minimum or very small because all parts from wood can be utilized efficiently.

The timber yield is approximately a half from log-m³ (approximately 2 m³ logs are needed for 1 m³ of timber produced and all the rest (~1 m³) is a by-product in respect to timber). Different mills have slightly different timber yields, depending on log characteristics such as diameter, length and position in sawing, but it is crucial for timber assessment if double the amount of wood material is counted as raw material for one unit of timber produced or if only one unit is needed for one unit of timber and the impacts are correspondingly allocated to timber and by-products.

The main rule is to avoid allocation by dividing the unit processes into different sub-processes, but in the cases where the process cannot be subdivided into two, allocation shall respect the main purpose of the processes studied, allocating relevant products and functions appropriately.

When the study is for sawn timber, the raw materials come from the forest. One question is how the forestry management should be dealt with, because it also serves other products, which are raw materials for other industries. A reasonable allocation method for forestry is mass allocation. But in saw mills, where the main purpose of the process is to produce sawn goods, it is reasonable to allocate all impacts to the main product.

In general, the allocation procedure that should be selected depends on material and market characteristics and the purpose of the study. Several by-product allocation procedures (value allocation, mass allocation, etc.) are possible and described in ISO 14044 [10]. Regardless of which allocation method is chosen,

according to the prEN 16485 [12], the inherent properties like biogenic carbon and energy content should be allocated according to the material physical flows.

Energy consumption

Sawmill activities include log handling, processing, sawing, drying, refining, space heating, lighting, internal transportation, and packing. The operation needs energy, and the amount and type has an influence on the environment. The main energy type in operation is heat, which is mainly used for timber drying. The mills have many alternative ways to generate and use energy, and they all bring about their own methodological questions for LCA. (The methodological choices here are given in parenthesis).

- Own by-product incineration (used by-products have an impact from forestry);
- Bought by-product incineration (used by-products have an impact from forestry);
- Own energy use (CO₂ emission from biomass incineration is considered as 0);
- Sold power (power is considered as the by-product);
- Sold heat (heat is considered the by-product);
- Bought power (country average, electricity production calculated for CHP plants according to the benefit share allocation method, but also energy, exergy and other methods are in use);
- Bought heat (environmental impact based preferably on the specific heat producer data if not known, then the average country specific district heat data could also be used).

Timber products are special dry timber for carpentry needs (dried till ~12%), shipping dry timber (dried till ~18%) and unseasoned, green timber (not dried). Annual production of the types depends on market needs, and because of the different amount of energy

F.5.3-3

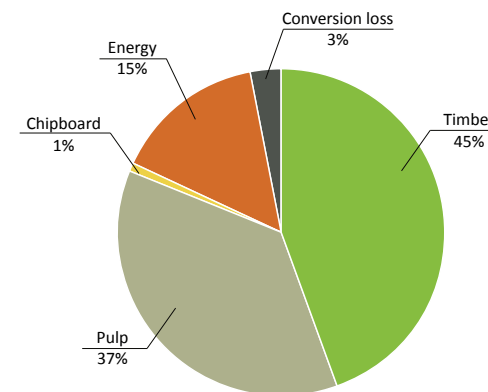

F.5.3-4

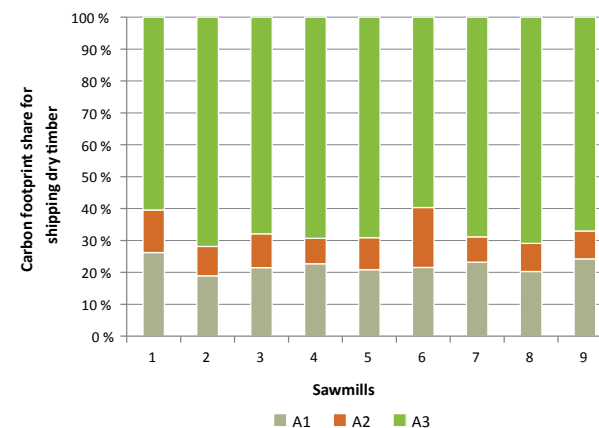

F.5.3-4 Use of lofs in Finnish sawmills

F.5.3-5 Carbon footprint and share of life cycle stages (A1, A2, A3) for shipping dry timber, Finland

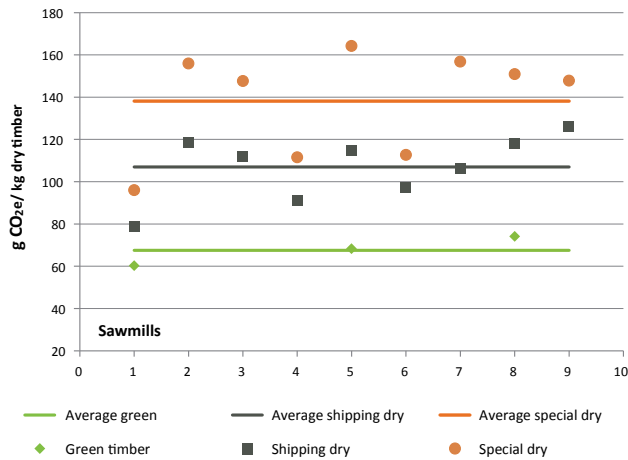

F.5.3-6

F.5.4-1

	Heat	Electricity
Log handling	0 %	2–10 %
Sawing and post-treatment	0–5 %	15–30 %
Drying	80–90 %	30–50 %
Trimming and processing of sawn goods	0–5 %	2–10 %
Further processing	0–20 %	20–35 %
Other premises: spaces, maintenance etc.	1–10 %	1–5 %

F.5.3-6 Carbon footprint for timber produced in Finland (as a dry product)

F.5.4-1 Distribution of heat & electricity between different processes in sawmills

needed for unequally dried products, it is important to assess the product types separately, not as the mill’s average timber.

Assessment results also depend on the electricity consumption and the production type. Supplied electricity is a mix of different fuels, energy types and technologies. In Europe, there are countries where a majority of electricity is produced by utilizing renewable hydro energy, but also countries where the main fuel type is fossil coal. The mills located in different countries and having the same electricity consumption may still cause a very different carbon footprint result only because of the unfavourable electricity supply mix.

Carbon footprint and product stage

The product stages are A1 (raw material), A2 (transportation) and A3 (manufacturing) [10]. According to the survey, raw material acquisition may cause 20–30%, transportation ~10%, and manufacturing 60–70% of the total carbon footprint emissions in the case of shipping dry timber. The survey results are shown in Figure F.5.3-5.

The shares between mills and product stages are quite similar, but the total amount varied a lot depending on the energy consumption in the mill, the utilization of by-products for drying, and the timber types produced.

As the timber is produced for different applications, a different amount of seasoning is needed. Special dry, shipping dry and unseasoned timber consume different amounts of energy for drying, but the energy type for drying could also vary from renewable to non-renewable source. When heat is created from the wood-based co-products, then CO₂ emissions comes from renewable sources, and it is taken as a net zero value in the carbon footprint assessment. But when this co-product is sold out and heat is bought from a non-renewable source, then heat used for timber drying causes CO₂ emissions. For example, 1 kWh energy from natural gas, consumed in the drying process, causes ~220 g of fossil-based CO₂ emissions, but when the bark or dust is used, then the fossil-based CO₂ emission is ~0.

Because of that, it is desirable that country-specific assessments always exist, the result covers as many mills as possible, and the result is presented separately by timber types produced.

The carbon footprint result for special dry, shipping dry and unseasoned timber for Finland mills and the average are shown in Figure F.5.3-6.

5.4 Optimization and development aspects of current manufacturing processes

L.Linkosalmi

Energy saving potential

The energy-saving potential in the woodworking industry can be divided into heat and electricity. Many woodworking industry processes need heat and electricity. Electricity is needed in all phases of production, whereas heat is needed mainly in the drying phase. Potential energy saving aspects are always mill-specific and need to be identified case by case. Table F.5.4-1 shows the ration of heat and electricity use in the different process phases in sawmilling.

Some general coherence can be identified in energy saving potential. There is no need to reduce the use of heat because heat for manufacturing processes is normally gotten from residues of the process. A heat plant is normally located next to a production mill, and fuel is coming from the process (bark and wood particles). Mills are self-sufficient according to fuels and can often produce even more heat.

Improvement potential:

- Renewable energy sources should be introduced
- Heat and electricity, in case of a CHP plant, could be distributed and sold out.
- Different drying systems in the woodworking industry could be developed to increase the heat efficient of dryers.
- Use of Best Available Technologies (BAT)
- Transportation efficiency of raw materials

Carbon efficient potential

In the case of carbon efficiency, the main focus should be to reduce fossil greenhouse gas emissions, although biogenic GHG emissions can also be reduced from an energy saving perspective.

As presented in the previous section (5.3), the carbon footprint of sawn timber will come mainly from the manufacturing phase and less from the forestry and transportation phases. Table F.5.4-2 shows more specifically how the carbon footprint is divided between different phases in sawn timber production.

In plywood manufacturing, GHG emissions are distributed differently than saw timber manufacturing. In plywood manufacturing, adhesive and other raw materials have a big effect on the raw materials GHG emissions (approximately 50% of all GHG emissions). Table F.5.4-3 shows more specifically how the carbon footprint is divided between different phases

The general ratio for different products or phases cannot be stated because of differences in the manufacturing process. Forest types and forestry varies within Europe, and transportation distances and transportation methods also vary. Techniques used in production and drying methods also have an influence. Main effects to the greenhouse gas emissions have in used electricity and heat sources. Countries have different kinds of electricity mixes, and those can also be varied year by year according to the availability of different electricity sources such as hydro power. Heat for the process is often produced from residue, but can also be produced from fossil fuels (e.g. natural gas).

When the production of upgraded products is studied, manufacturing and transportation have a smaller effect on the carbon footprint. A case study made in Austria shows differences in window manufacturing for two frame types. The main effect on the carbon footprint have materials production; the actual manufacturing of windows and the transport of materials have a minor role in the carbon footprint.

Glazing has a major effect on the carbon footprint of windows. Aluminium also has a big effect on wood-aluminium-frame windows. (Figures F.5.4-4 and F.5.4-5)

F.5.4-5

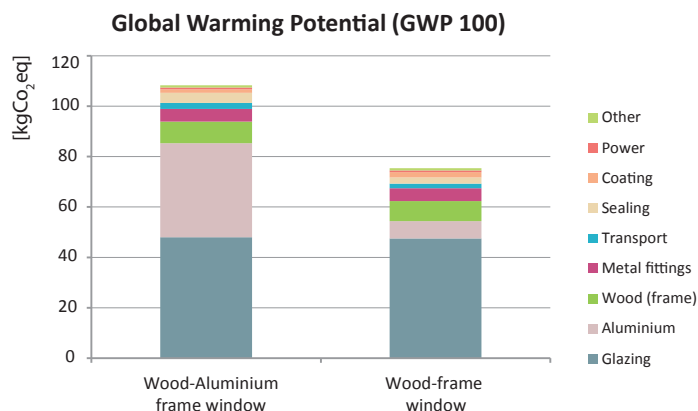

F.5.4-4

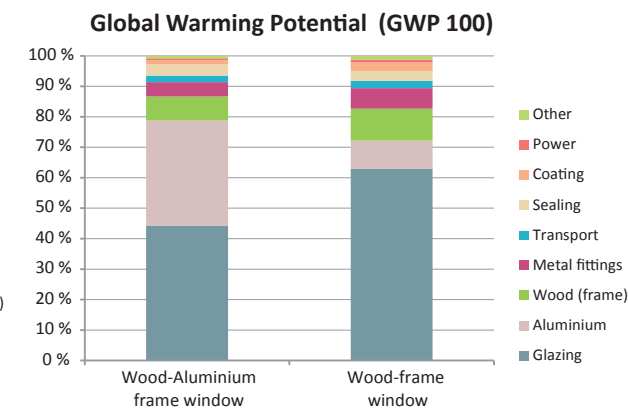

5.5 Conclusions

T.Häkkinen

As discussed in this section, geographical and country-specific differences have an effect on the carbon footprint of wood-based products. Climatic differences between Northern, Central and Southern Europe have an effect on forest species and how logging is done. Country-specific energy mixes impact greenhouse gas emissions.

Greenhouse gases from the production of sawn timber vary a lot, depending on the energy consumption in the mill, the utilization of by-products for drying, and the timber types produced.

The most important stage of the production process with regard to energy consumption is the drying process. For example, for shipping dry timber the drying phase may be responsible for 80–90% of heat energy and for 30–50% of electricity. Thus, the average results should not be used in LCI calculations of wood products, but the data should represent relevant wood materials in terms of their required moisture content and quality.

In order to correctly assess the environmental impacts of sawn timber, detailed information about the production processes is

	Share of GHG emissions %
Raw material	~70
Transportation	10-15
Production	10-15
Drying	5

F.5.4-3

	Share of GHG emissions %
Raw material	15–30
Transportation	5–20
Sawing process	30–50
Drying	0–40

F.5.4-2

F.5.4-2 Distribution of GHG emissions between different processes in sawn timber production.

F.5.4-3 Distribution of GHG emissions between different processes in plywood production [13]

F.5.4-4 Share of different phases in the carbon footprint of the windows.

F.5.4-5 Carbon footprint of different phases of window manufacturing.



needed. The most important information includes accurate data about the division of the original log to different product flows and moisture content. It is also important to pay attention to the fact that the moisture content varies along the production chain.

The potential to improve the carbon efficiency of a process is to control the manufacturing and drying processes to reduce energy use and at the same time decrease greenhouse gas emissions. Renewable energy sources should also be introduced while not forgetting the energy saving potential.

The environmental profile of sawn timber and its correct calculation is of utmost importance for the assessment of all other products including the final end product – a wooden building. If mistakes are made, it affects the whole value chain.

F.5.5-1 Drying chamber at the sawmill, Sweden

- [1] FAO, 2002. Forest Products 1996–2000. FAO Forestry Series 35. Rome: FAO.
- [2] CEI-Bois, 2012. Tackle Climate Change: Use Wood. Brussels.
- [3] MCPFE, 2007. State of Europe's Forests 2007 – The MCPFE report on sustainable forest management in Europe. Warsaw: MCPFE.
- [4] Schwarzbauer, P., 2009. Die österreichische Forst-, Holz und Papierwirtschaft. Größenordnungen – Strukturen – Veränderungen, in Ergebnisse zum Projekt "Technologie-Roadmap für Holz in Österreich". Band 23. Vienna: Universität für Bodenkultur.
- [5] Pröll, W., 2006. Mechanisierung der Waldarbeit. Hg. v. Vienna: BFW Bundesamt für Wald.
- [6] FAO [online] Available at: <<http://www.fao.org/forestry/country/57478/en>> [Accessed 30 November 2012].
- [7] Ecoinvent ed., 2012. Data v2.2. The Life Cycle Inventory. Ed: St. Gallen: Swiss Centre for Life Cycle Inventories.
- [8] Vares, S., 2013. Environmental aspects and CO2e emissions from sawn timber production (StoraEnso) (VTT research report VTT-CR-01788-13, confidential, not published). Helsinki: VTT.
- [9] Vares, S. 2013. Environmental aspects and CO2e emissions from sawn timber production (UPM) (VTT research report VTT-CR-01789-13, confidential, not published). Ibid.
- [10] ISO 14044 Environmental management – Life cycle assessment - Requirements and guidelines.
- [11] EN 15804 Sustainability of construction works – Environmental product declarations – core rules for the product category of construction products.
- [12] prEN 16485 Round and sawn timber – Environmental Product Declarations – PCR for wood and wood-based products for use in construction.
- [13] Haaparanta, L., 2011. Life Cycle Assessment of Plywood Process – Carbon Footprint of Two Plywood Products. Masters thesis, Aalto University. 83 p.



6. Good practices for carbon efficient wood construction



72

6.1 Goal setting and requirements

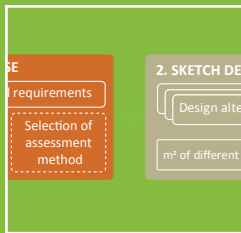

75

6.2 Design of a low carbon wooden house

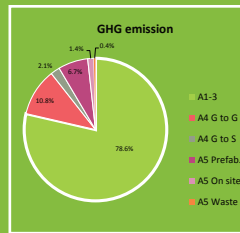

78

6.3 Construction



85

6.4 Use and maintenance



89

6.5 Deconstruction and recycling, end-of-life



95

6.6 Conclusions

6.1 Goal setting and requirements

A. Hafner, S. Ott, S. Winter

In this section, the scope of LCA and carbon footprint is to describe the environmental properties in the lifecycle of a building. It is done to improve the environmental performance of buildings. Therefore the borders of practical LCA as described in Section 4.5.2 are applied.

The use of wooden material for buildings involves some major advantages: the environmental impacts of wood are beneficial especially in terms of greenhouse gases and renewable primary energy. Also carbon is stocked in material and is regarded as a carbon sink. In terms of primary energy, renewable wood shows benefits. Here the embodied primary energy in material is a positive attribute for the end-of-life phase because it can be consumed. This can be shown through LCA and carbon footprint.

External benefits from such carbon efficient construction can include:

- Marketing for low carbon constructions;
- Improved reputation;

F.6.1-1

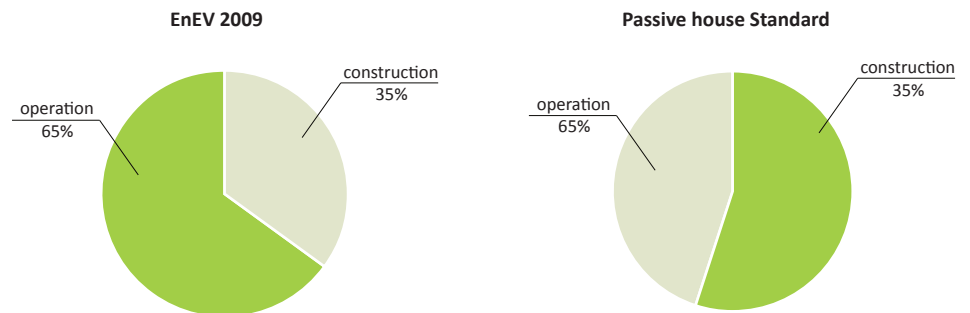

- Enable stakeholders to understand the true values of selected construction.

LCA calculation in lifecycle

Up to now, the operation phase has been regarded as the most dominant in the life cycle of buildings in terms of energy consumption resulting in greenhouse gas (GHG) emissions. Here the energy standard of the building envelope interacts with the energy consumption in the use phase and the used energy sources. Much attention has been paid on reducing energy usage in the operation of buildings, and several types of energy-efficient houses have been developed. As a result of decreasing the energy consumption in the operation phase, the other life cycle phases become more important (Figure F.6.1-1). Maintenance in the use phase is also important for calculations in the life cycle. Maintenance depends highly on the durability of materials and their exchange rate. For more information, see Chapter 7.

For buildings achieving a high energy standard, the impacts of module A can have an overall effect up to 50% or more. Therefore more attention needs to be given to the module A phase. And with that, the choice of building material comes into focus.

In module A, especially the production phase of building components (module A1-A3) has been discussed actively in connection with LCA of construction products. However, there have been few detailed assessments for construction work (module A4-A5). For more information, see Section 6.3.

Strategies for goal-setting

The preliminary goal-setting for sustainable building is done by the owner. Targets are outlined for building performance, environmental impact and economic impact. Building performance can be divided into the following elements: functional, technical and social qualities. Life cycle targets are also high-level targets that are important for sustainable buildings. When the project receives a positive decision, this stage ends up in the formulation of the target definition document. Environmental targets should be set with the help of core environmental indicators and contain at least carbon footprint, primary energy non-renewable and water. Detailed target setting needs information about relevant benchmarks. Benchmarks are already in development for sustainable buildings. This can be used as a possible reference.

When a competition program for sustainable building is created, it is necessary to define assessment methods and system boundaries



F.6.1-2

F.6.1-1 Dominance of construction and operation of different energetic standards in a life cycle analysis of an exemplary comparison

F.6.1-2 Detail of the facade from Augsburg – Grünenstr. housing building

to achieve comparable assessment results. At the beginning of a project, it is vital for achieving carbon-efficient construction to set clear goals for the project. See also Figure F.6.1-2.

The goals can be the following:

1. Documentation of the carbon footprint
2. Internal quality control
3. External certification of the building
4. Optimization of environmental performance of the product

Goals can be reached for all phases of the life cycle. But not all goals can be reached at the same time.

- Documentation of the planning phase
- Documentation of the as-built state

For the documentation of carbon footprint performance, two main strategies are available, both influencing each other:

Quality control is related to goal-setting or benchmark use to reach a certain level of quality. Quality control can be done individually for each stage of the building project as shown in Figure F.6.1-2. It can also be part of an iterative process for monitoring the whole project. The achieved results are continuously compared to the set targets. When targets are not met, either corrective actions should be done or – in the case of justified reasons – the targets should be reformulated.

- Start goal-setting with the pre-design phase
- Use as a decision-making tool
- Optimization of the design phase
- Control of the production and prefabrication phase
- Documentation of quality

In various stages, quality control focuses on different issues:

External certification of the building is related to available systems on the market (BREEAM, LEED, BNB/DGNB, etc.). It has to follow the rules of these systems. The most recent systems take LCA calculations (DGNB, Openhouse) into account. In terms

of optimizing construction based on ecological matters, there can be differences in the perception, as some systems only include GHG emissions and others use a wide range of indicators. It has to be noted critically that for a holistic understanding, it is not sufficient to assess only carbon footprint. Issues of resource- and water efficiency have to be considered.

Optimization of the product “building” throughout the whole development of building is the most advanced or demanding task. It is an iterative process. Several steps have to be made towards an optimized solution from defining first goals, alternative solutions, problem identification, improvements, etc.

This has to be done especially for all steps of the design process and also for the production process. It can or should cover all stages or phases of life cycle.

Requirements for practice

Design phase

- Strong influence on the primary structure (material) decision
- Definition of the required service life
- Energy demand goals
- End-of-life scenario choice

Pre-project stages allow the following:

Nowadays lifecycle assessment calculations often get commissioned during the planning process to be realized for buildings. With the results, the clients tend to decide which materials to use and then use the results for their marketing. Results and advantages of LCA need to be shown in a transparent and understandable way. If the results are not as promising, options for improvement should be shown. Up to now, improvements consist mainly in energy performance, as this still has the main influence. Improvements also can be made by reconsidering the durability of materials, as this influences the maintenance in use phase. Also adjustments in material choice for construction of buildings are possible. Here material choice and functional use of material are connected.



F.6.1-3

For example, foundations have a huge effect on share of primary energy and GHGs. Section 6.2 deals with the design of a low-carbon wooden house.

Production phase

- For producers of buildings: results help to optimize the production, lower energy demand and less GHG. Prefabrication processes can play a dominant role for wooden buildings. Chapter 5 discusses the sustainability aspects of the production phase.
- For the planner and client: Minimize the use of primary energy and GHG in the production and erection of a building. Here wood can show its advantages by storing carbon. For steps to fulfil the requirements, see Figure F.6.1-2.

Assessment can have various benefits – on the producer side as well as on the planner side.

6.2 Designing a low-carbon wooden house

M. Kuittinen, T. Häkkinen

In the early design phase, there is often not enough information available that is required for making a life cycle assessment. In a standard-based LCA, it is allowed to cut off parts of the assessment that have less than 1% significance for the end result. Because this cannot be known without conducting an exhaustive LCA, it is formally very difficult to assess the carbon footprint in the early design stage.

The design of a building can be simplified into the following stages:

Phases

1. Pre-design
2. Sketch design
3. Final design
4. Working drawings
5. Tendering
6. Construction supervision
7. Final documentation

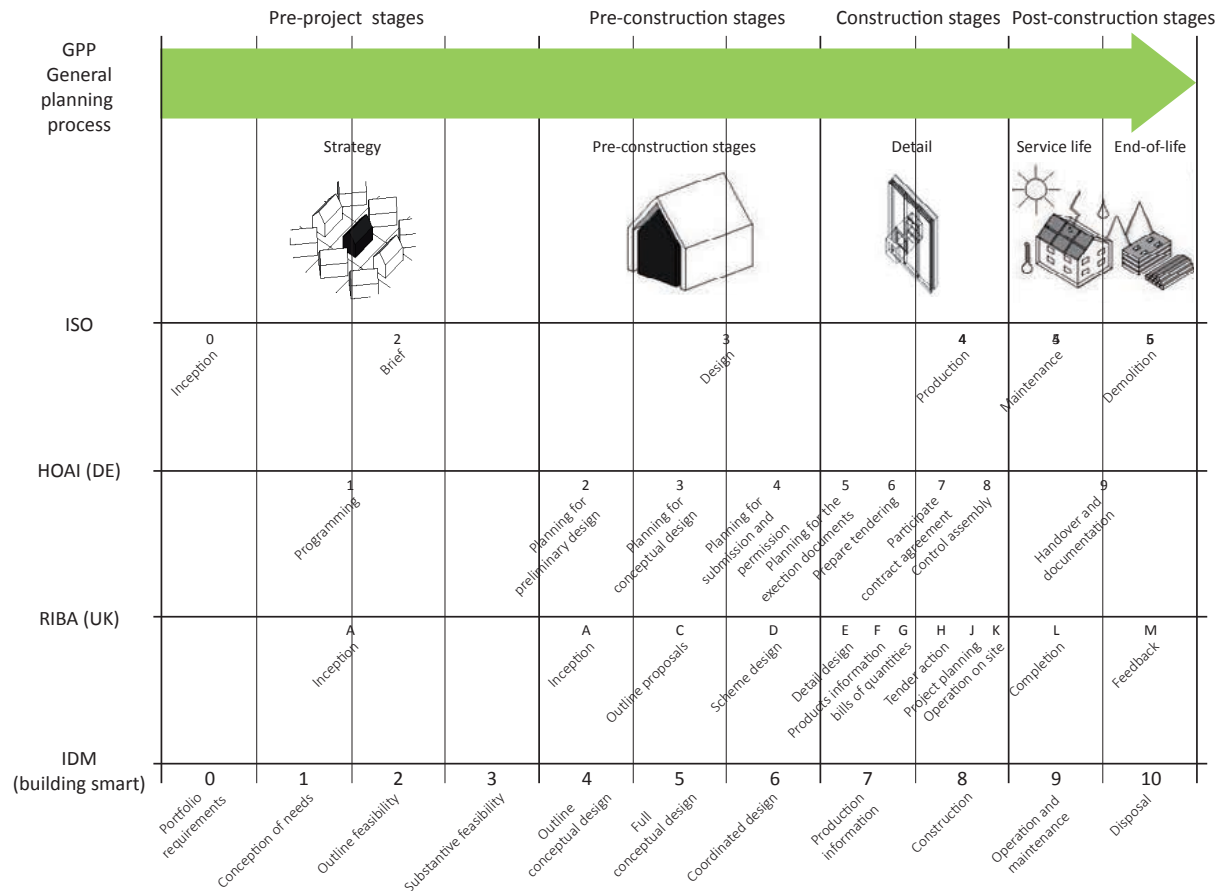

F.6.1-4

- F.6.1-3 CLT school in Eggllham, Austria
- F.6.1-4 Strategies for goal setting and requirements

- Goal setting for carbon efficient buildings must be done by the owner at a very early stage.
- With the increase of energy efficiency in the use phase, the primary energy for construction becomes important.

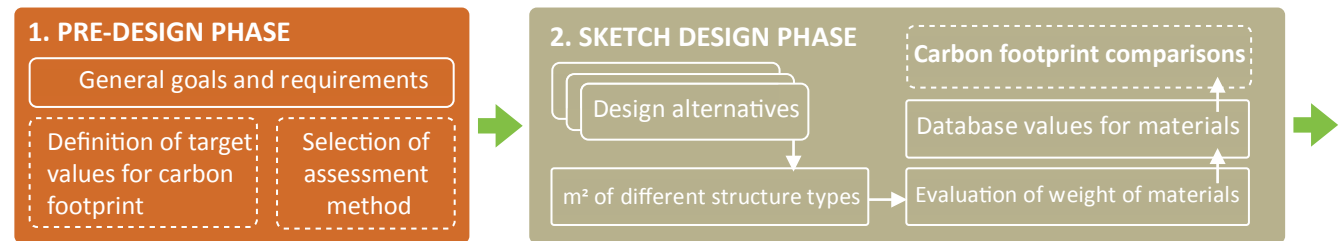

F.6.2-1 Schematic diagram for the design process of a low carbon wooden house

In the following, the potential for designers to influence the carbon efficiency of the building is discussed.

■ Pre-design phase (1)

The pre-design phase should provide the designers and construction teams with goals and metrics for achieving the required carbon footprint levels in the building. Therefore the selection of the methodology for carbon footprint assessment is very important. Using normative technical standards – such as EN or ISO – is usually the most relevant approach since they are followed by industry and authorities. The possible reporting and documentation of CFP for other uses also needs to be considered so that all carbon footprint-related information can be gathered in the required format. Such uses can be requirements from authorities, possible green building certification schemes (LEED, BREEAM, DGNB), public communication or marketing materials.

Furthermore, a clear functional unit for carbon footprint assessment should be decided upon. Typically, the relevant functional units are m^2 of gross or net floor area or m^3 of gross or net volume of the building.

The selection of goals and methodology should be done by the client or mandated to an experienced LCA or carbon-footprint assessor.

■ Sketch design phase (2)

Preliminary design seems to be the most important of all operative phases in meeting the required carbon footprint level. All major issues – such as size, shape and orientation of the building, construction materials, functions and energy concept – are solved in the preliminary design phase. The following design phases are usually bound to these decisions, and the later influence is deemed to have only an iterative nature.

Given the high importance of the preliminary design phase, it requires the well-planned cooperation of the design team from the beginning, as already recognised in near zero energy buildings design projects.

The preliminary design phase should also include a preliminary carbon footprint assessment. That can be based on comparing initial mass calculations – with the help of BIM – to general environmental data of construction materials and products. Such data is provided by construction federations or acquired from databases. Since material providers are normally not known at this phase, the preliminary carbon footprint can only give rough estimations. Still, it can show differences between design alternatives and is therefore valuable in decision-making. However, if more accurate carbon footprint figures are required in preliminary design phase,

a correction factor should be used to normalise the results of preliminary carbon footprint estimation.

■ Final design (3)

The final design follows the preliminary design proposals that have been accepted by the client or his representative. This acceptance should also include the acceptance of the practical means to reach the required carbon footprint level per selected functional unit.

For the acceptance, the design team should give a detailed carbon footprint estimation that is based on finished design, preliminary bill of quantities, and the energy certificate of the building.

If the building will be marketed, the carbon footprint estimation can be used along with green building certification pre-certificates, such as LEED, BREEAM or DGNB.

■ Working drawings (4)

Working drawings from each member of the design team enable a detailed assessment of the carbon footprint of the building, based on reliable technical information such as the environmental product declaration (EPD). Based on initial research findings, the

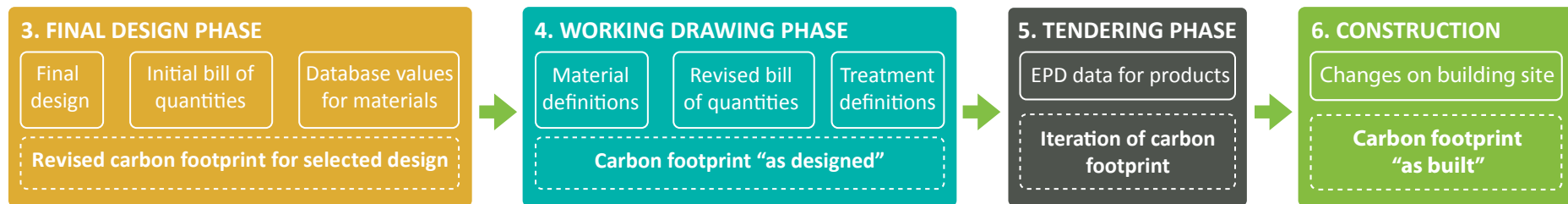

carbon footprint estimation at this stage will be relatively close to the final carbon footprint calculation at the construction stage.

The use of BIM is also recommended since the changes in design can be directly observed as changes in the bill of quantities, and its changes can be taken into the carbon footprint assessment. At this point, it is possible to calculate the carbon footprint for "building as designed". However, changes in the following phases can still alter the carbon footprint of "building as constructed".

From the designer's viewpoint, the easiest way to calculate buildings carbon footprint would be to rely on EPDs. In reality they are still not available for all products. However, there can be significant differences between the carbon footprint of a product manufactured by different companies because of different energy sources or transportation distances. If a designer wishes to ensure an easy comparison of materials' carbon footprint performance in later phases, there should be a claim in the building documentation about using or preferring products that have an EPD. Otherwise it will be time-consuming in practice to evaluate the carbon footprint effect of a change of product in the tendering and negotiation phases. So at this point at the latest, all database data that has possibly been used for carbon footprint estimations should be replaced with data from EPDs.

■ Tendering (5)

Typically, iteration in the tendering phase deals with finding alternative materials or treatment methods for certain products. From the carbon footprint viewpoint, this is a delicate issue since economic preferences tend to dominate and because material tendering is often given to competing construction companies. The design team and assessors seldom have a strong influence on their choices. Therefore the client should ensure a sufficient amount of consultation between construction companies, material providers and the design team or assessors in order to ensure that materials or working methods will not jeopardize the carbon footprint goals.

■ Construction supervision (6)

Supervision during the construction phase usually deals with solving encountered construction problems or detailing. In such consulting, material-related changes that might alter the carbon footprint balance are less likely than changes that are related to construction work. Changes in construction work may require deconstruction of wrongly built parts, repeated surface treatments, replacement of broken components or similar tasks. Although a designer might choose not to demand that a mistake be repaired

in or to maintain keep the carbon footprint levels as planned, other functional, normative or technical reasons often force such changes to be carried out. Therefore, special attention must be paid to the supervision of the building site. Possible losses, surplus orders of materials, mistakes or accidents will inevitably lead to greater carbon footprint than planned.

Therefore the final carbon footprint of a building should not include the construction phase, because a strict carbon footprint level would lead to shortcuts on the building site. Especially rainy or cold construction conditions may significantly add to the energy demand on the building site, let alone possibly require re-casting of concrete with an accelerated drying time requirement with the help of chemicals and heat.

Supervision during possible repairs and renovations is comparable to a new construction project. Depending on the scale of the renovation, all previously described steps can be adapted if the carbon footprint goals are set for the renovation.

Final documentation (7)

Preparing a plan for changes and deconstruction is a recent proposal of environmentally conscious design. It is mostly a

responsibility of the design team. Because very few examples of “design for deconstruction” exist to date, this task can be based on considering the construction steps in reverse order. If components of the building can easily be deconstructed with typical machinery, the carbon footprint in module C is likely to remain on a similar scale as in module A4-5.

The moisture content of deconstructed material that is aimed for re-use or energy recovery has to be optimized. If feasible, it would be advantageous to keep energy waste dry, so that its energy content would not decrease.

Towards carbon-conscious design

If the building sector wishes to contribute to the reduction of greenhouse gases and primary energy use, a systematic design process needs to be developed. As the operative energy use is reduced along with better energy efficiency, other parts of the life cycle increase their share in the emissions of a building’s life cycle.

The motivation for reducing the carbon footprint of buildings is not yet financial. As long as there are no direct normative requirements for it in the EU, low-carbon house projects have so far remained on an experimental level and are based on ideological choices. If the legislation changes towards including emission taxation on construction products as well, economic reasons could start increasing interest in carbon-efficient design and construction.

To ensure that there is enough reliable data for designers, product manufacturers should start preparing EPDs in a comparable way. Construction associations or related organisations could collect that data and make it available.

Today, carbon-efficient design is a differentiating opportunity for designers and construction companies. Tomorrow, it is likely to be included in regulations. Pioneers will have the easiest adaptation periods and gain a competitive advantage.

6.3 Construction

A. Takano, F. Pittau

6.3.1 Introduction

In this section, a feature of the environmental impact from the construction stage (module A4-5) is reviewed through literatures and case studies.

In a building LCA or carbon-footprint calculation, major attention has been paid to the use phase of a building due to its high share of environmental impact in a building life cycle. As a result of such effort, the impact from the use phase has been mitigated and the importance of the other life cycle stages has increased [1]. In general, the construction material production phase has been regarded as the next target of mitigation, and the other phases (such as construction, transportation and demolition) have not had priority because those phases normally account for a small proportion of the life cycle environmental impact [2]. It was reported that the construction phase contributes less than 10% of the overall life cycle impact of a building in many cases [3, 4, 5]. Therefore, the impacts from the construction phase have so far been ignored or just estimated in many studies [6].

However, recent research papers have mentioned that the construction phase has a relevant impact, and the trend of GHG emissions from construction equipment has increased significantly in the last decades [6, 7, 8]. They have claimed that the process should not be underestimated and they have attempted to establish the framework for environmental management during the construction phase. Although an optimization of the construction phase may not have a significant effect on the overall life cycle impact of a building, it would have a major impact at an industrial (aggregated) level. The environmental impact of the process should be known in order to optimize it for constructors and designers.

To review the environmental impact of the construction work, detailed data collection and the assessment for construction work have been conducted for three reference buildings: Mietraching (Germany), Joensuun Elli (Finland), and L’Aquila (Italy). Since the

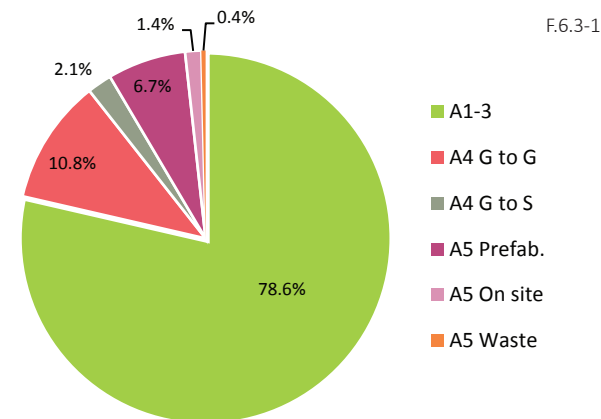

F.6.3-1

GHG emission (kgCO₂-eq/m² of living area)

A1-3	A4 G to G	A4 G to S	A5 Prefab.	A5 On-site	A5 Waste
171	23	5	15	3	1

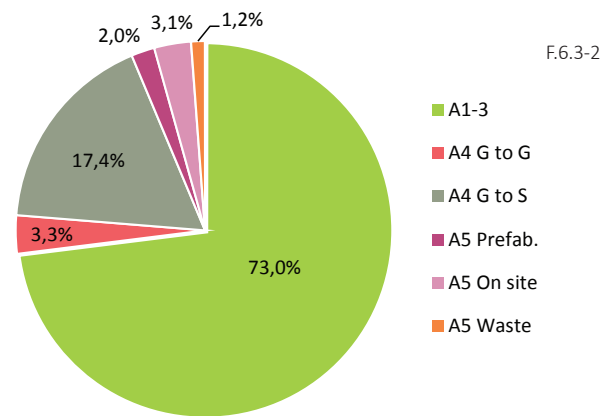

F.6.3-2

GHG emission (kgCO₂-eq/m² of living area)

A1-3	A4 G to G	A4 G to S	A5 Prefab.	A5 On-site	A5 Waste
283,9	12,7	67,6	7,8	12,2	4,6

F.6.3-1 GHG emission during the production stage of Mietraching

F.6.3-2 GHG emission during the production stage of L’Aquila

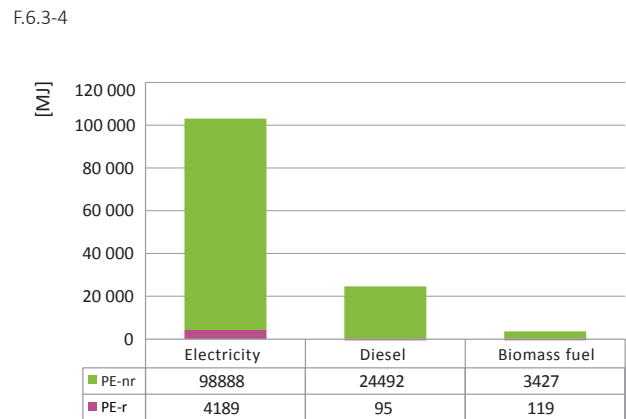
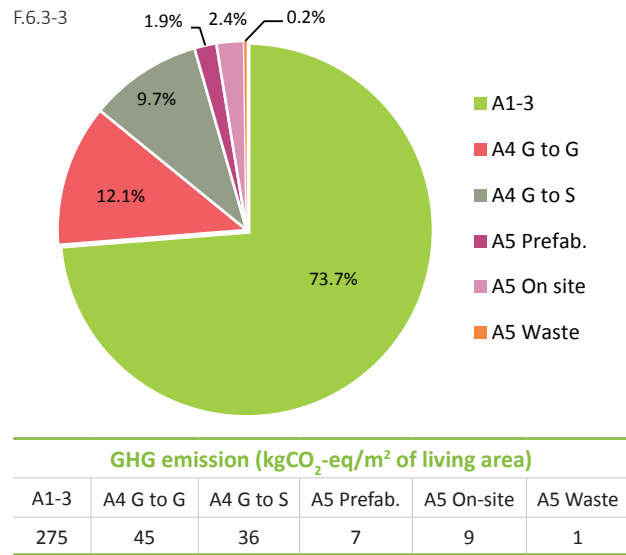

F.6.3-3 GHG emission during the production stage of Joensuu Elli
 F.6.3-4 Primary energy consumption during the prefabrication process of Mietraching (wooden building elements only) according to the consumed energy resources

specification of a basement differs significantly between the reference buildings and there are several uncertainties in non-wooden building element (e.g. prefabrication of steel staircase), the results shown in this section are limited to the material production and construction stage of the wooden building element of the buildings in order to make the results comparable. General information of the reference buildings, assessment condition, and LCA results with full inventories are described in Chapter 8: Case studies.

Based on the study results, possible improvement points, required documents for the assessment, uncertainties, and limitations of assessment are also discussed. The purpose of the study shown in this section is not to accurately quantify the environmental impact of construction work, but rather to understand the outline and to demonstrate LCA following a real construction process. Thus, the results are based on a limited condition of assessment and are not comparable with other study results.

6.3.2 Dominance of construction phase

Figure F.6.3-1 shows a dominance of each phase in the production stage (module A1-5) of the Mietraching building regarding GHG emissions. The material production phase (A1-3) and the construction phase (A4-5) account for approximately 80% and 20% of total GHG emissions, respectively, for the production of wooden building elements. In the construction phase, the transportation of products from the production gate to the prefabrication gate (G to G) and prefabrication process (A5) has a major impact.

Since the wooden building element of Mietraching has been fully prefabricated in the factory, including exterior cladding, windows, and doors, on-site assembly work has taken only about three weeks including all secondary work. This high level of prefabrication is reflected in the result. The waste management mainly consists of incineration of wood residues from prefabrication and on-site construction work. Therefore, GHG emissions are very low in this phase.

Figure F.6.3-2 shows the same issues with the L'Aquila building case study. The results show a different trend from Mietraching.

While the material production phase still holds the most relevant share (73% of the total), the prefabrication process accounts for only 2% of the total, with on-site construction accounting for about 3%. The main difference can be seen at the on-site construction compared to Mietraching, since L'Aquila has a relatively low level of prefabrication within the wooden building elements. Also transportation plays a fundamental role, accounting for approximately 3% from gate to gate (G to G) and approximately 17% from prefabrication gate to building site (G to S). Waste management plays a less relevant role, with a minor influence on the overall result.

Figure F.6.3-3 presents the results of Joensuu Elli. The material production phase (A1-3) holds approximately 75% of the total emissions. One remarkable point is that the transportation process (A4) accounts for approximately 20% of the total, and actual construction work contributes very minor GHG emissions. This result originates from the very long transport distance of the main structural material and prefabricated building elements. (See Chapter 8: Case studies.) The on-site construction process has a very minor share in the total because of a high prefabrication level, as with the Mietraching building.

From these three results, it is understood that the material production phase (module A1-3) accounts for approximately three-fourths and the construction phase (module A4-5) holds approximately one-fourth of GHG emissions in the production stage of wooden building elements. Although there are some differences in each case, the trend is clear. In addition, it is remarkable that the transportation process, module A4, has a relevant impact. The L'Aquila case shows relatively higher GHG emissions in each phase than the other two cases because it was a renovation project in a stricken area.

6.3.3 Construction process: Prefabrication

From this section, each unit phase in the module A4-5 is reviewed individually.

In order to secure the accuracy and work efficiency of construction, prefabrication is the main construction method in northern and

central Europe. Regarding LCA of prefabrication work, possible inventories are electricity consumption for a production line in a factory (e.g. construction machine operation, lighting, and ventilation machine operation), space heating/cooling energy, and fuel for operation of construction machineries. Basically it is not easy to collect these data accurately from a company due to lack of resources and time in the current situation of the industry. In addition, several projects are going at the same time in a factory. Therefore, the allocation of consumed energy and used material to each project needs to be considered.

One of the most important purposes of LCA in this phase for the industry would be to get a hint for the optimization of the process. Therefore, it would be more important to understand a dominant process in the production line and find out possible remedies rather than knowing an exact value.

As an example, Figure F.6.3-4 shows the primary energy consumption value for the prefabrication process of Mietraching according to the consumed energy resources. Electricity is dominant; it is consumed in machine operation, lighting and ventilation of the factory. Diesel is consumed in operating forklifts; and biomass fuel (wood residues from the prefabrication process), is for generating heat energy. Figure F.6.3-5 shows GHG emissions according to energy resource. From these figures, it is clear that optimizing electricity use during prefabrication is the first priority. The same trend could be seen in the prefabrication process in the Joensuu Elli case; about 95% of GHG emissions originate from electricity use (Figure F.6.3-6).

In principle, prefabrication work needs adequate floor area and space in a factory. Naturally the operation of such space consumes a large amount of energy. Space heating was the dominant energy consumer in both cases. However, as mentioned before, space heating energy is generated with process wood residues. Therefore, electricity use finally became the dominant factor for both primary energy consumption and GHG emissions during the prefabrication

A reduction in electricity use would be relatively easy. A good starting point would be optimization of the prefabrication process

(e.g. proper process management and scheduling), optimization of a factory operation (e.g. adjusting the brightness of the factory according to the weather and adjusting the ventilation frequency according to the season and the work). Electricity use for the operation of a factory seems to be larger than the prefabrication machine operation, which would mean a greater potential for optimization.

For the assessment, monthly electricity consumption, space heating/cooling energy consumption and bills for the fuel are a relevant information source. In order to allocate such energy consumption data into different projects running at the same time in a factory, the monitoring of working hours per project is helpful. This monitoring would also help to recognize which unit process consumes more energy and time in the production line. This distinction helps the optimization of the production process environmentally and economically. The physical basis (e.g. production volume or floor area of each section in a factory) can also be utilized for allocating consumed energy and materials. Direct monitoring of electricity use with a measuring instrument would be a relatively easy method as well and would provide more accurate results than the aggregated monthly data.

The assessment of this phase may tend to be rougher compared to the assessment of module A1-3 due to the current working situation in the industry (e.g., lack of resources). Due to a lack of information, this study also includes some assumptions based on the company's experience, the average value of the factory, and so on. A proper monitoring plan needs to be prepared in order to collect relevant data comprehensively. Further research and practice are required on this issue. The importance of managing prefabrication work from the environmental viewpoint will increase in the near future.

6.3.4 Construction: On-site work

Naturally the share of on-site construction work is affected by the level of prefabrication. When on-site construction work is only an assembly of prefabricated building elements, as in the case of Mietraching, the environmental impact from this phase is minor.

F.6.3-5

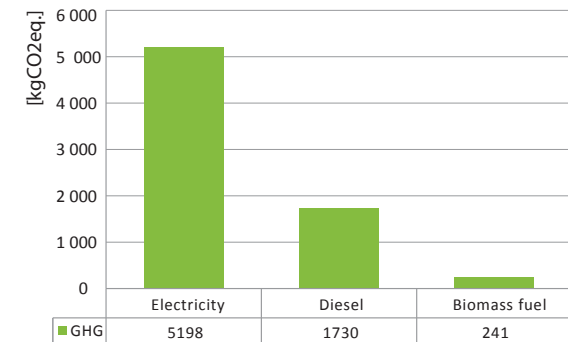

F.6.3-6

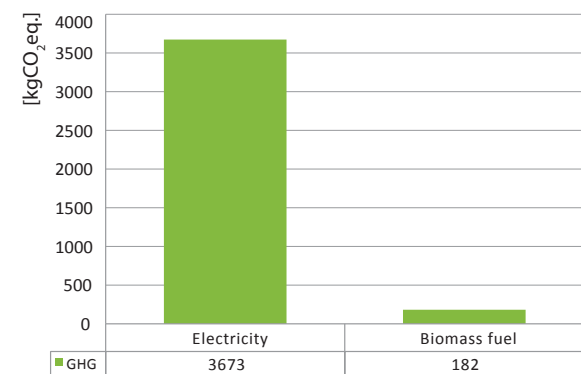

F.6.3-5 GHG emission from different energy source during prefabrication of Mietraching (wooden building elements only)

F.6.3-6 GHG emission from different energy source during prefabrication of Joensuu Elli (wooden building elements only)

F.6.3-7

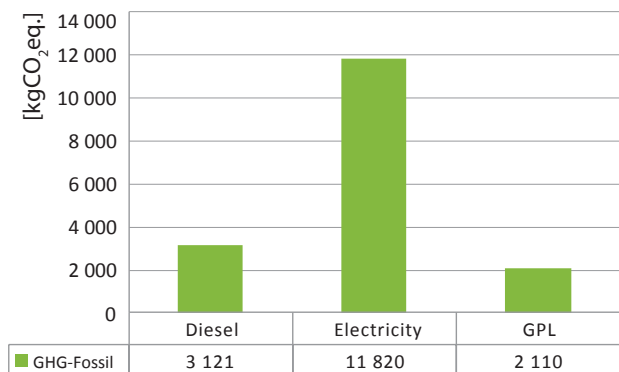

Where there is less prefabricated building, the relevance of this process increases, such as in the case of L'Aquila.

Figures F.6.3-7 and F.6.3-8 show GHG emissions and PE consumption from on-site construction work for the wooden building elements of L'Aquila according to the used energy sources. GHG emission from electricity use is dominant, since most of the equipment used in this phase works with electricity. Nevertheless only a single electricity meter was installed on-site, the allocation of the consumed energy to the single process unit has been done considering the hours of use of the single machines. Electricity is also used for lighting during the construction process during the night and for heating workers' bathrooms and locker rooms. Diesel is mainly used for transportation (building elements and waste products) and excavators, while GPL (which is responsible for the lowest GHG fossil emissions) is used only for waterproofing.

the case of L'Aquila building, being a construction for emergency, a special agreement was signed between client and contractors. The contract forced the different construction companies to respect the stringent planned time schedule for the construction of the building (maximum 3 months). As a consequence, each sub-contractor planned preventively in detail every working activity in order to respect the timing constraints. The type of equipment, machinery, number of workers and hours of work per worker, temporary equipment, and transportation of materials are accurately evaluated in order to optimize the duration of the construction work. Therefore, it was possible to collect relevant data relatively easily.

In the Joensuu Elli case, a researcher has been stationed on the construction site and monitored the process everyday with the constructors, resulting in accurate data collection. However, this way of monitoring would be the exception. It is not realistic to station an observer for only such monitoring on the construction site. Detailed planning and monitoring by the constructor themselves, like in the case of L'Aquila, would be a relevant way for both the data collection and optimization of the process. This may also help to enhance a worker's mind toward the environmental efficiency of their work. A good planning of the construction activity leads to a saving of money, improvement in quality, and the optimization of environmental impacts.

Monitoring of electricity consumption on a construction site could be easily conducted through the connection of a measuring instrument to electrical equipment. Nowadays there are different kinds of measuring devices available on the market, normally quite cheap, and some of them can directly share data on the Internet via a wireless connection. This kind of monitoring system provides more accurate results than the results from aggregated electricity consumption, allowing optimization of the most electricity consuming process or machine use.

F.6.3-8

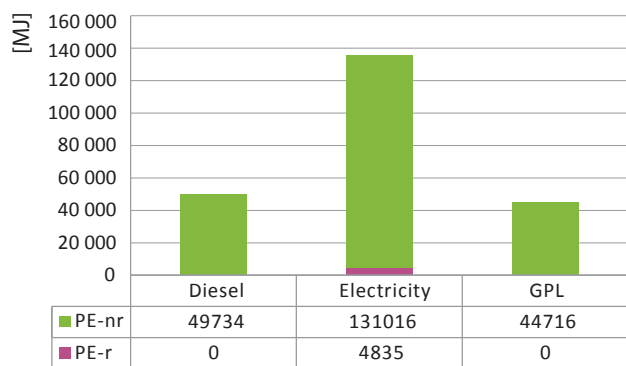

Figures F.6.3-9 and F.6.3-10 show the same issue with Joensuu Elli. Here diesel use shows a much higher value than electricity use in both primary energy consumption and GHG emissions. It is assumed that this result is mainly due to the electricity mix and simply many used of diesel in the construction process. The used Finnish average electricity mix data includes large biomass fuel use, which would result in lower primary energy consumption and GHG emissions than fossil fuel use. These two case studies indicate that the use of electricity and diesel during on-site construction needs to be considered evenly.

Since there was single electricity meter on the construction site, it is difficult in this case to determine the most critical factor for electricity use during the on-site construction work. However, it can be assumed that the temporary construction office and the construction heater are the main electricity consumers, based on experience visiting the site. Diesel is consumed by crane and boom lift for assembly of the building elements.

Data collection of on-site construction work is rather difficult. In fact, in addition to resources and time, special knowledge of construction may be required to monitor the on-site work. Since several sub-constructors are involved, it may be more complicated to monitor the work than prefabrication process in a factory. In

The assessment of this phase tends to be more difficult compared to the assessment of prefabrication work. The result might include significant uncertainties. Detailed construction planning for environmental impact management (reduction of energy consumption and construction waste, etc.) is important, associating

F.6.3-7 GHG emission from different energy source during on-site construction work of L'Aquila (wooden building elements only)

F.6.3-8 Primary energy consumption from different energy source during prefabrication of Joensuu Elli (wooden building elements only)

F.6.3-9

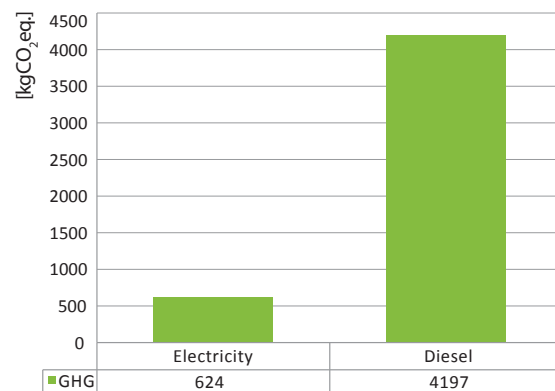

F.6.3-10

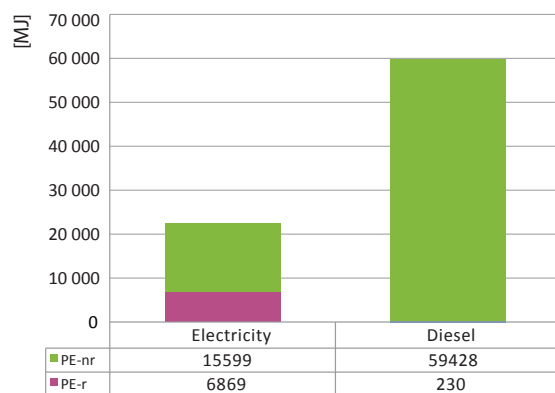

F.6.3-9 GHG emission from different energy source during on-site construction work of Joensuu Elli (wooden building elements only)

F.6.3-10 Primary energy consumption during on-site construction process of Joensuu Elli (wooden building elements only) according to the consumed energy resources

with cost management in advance. For instance, some researchers have proposed the building construction planning model in order to minimize the global warming potential of construction work based on the expected construction machines, number of workers, duration of works, and so on [7, 9]. Development of a practical and realistic assessment method is required, as is combining this kind of estimation method and feedback from real construction work.

6.3.5 Transportation

The environmental impact of the transportation process is dependent on the distance, vehicle type and weight of deliverables. In the Mietraching case, many building components have been delivered from Germany by truck. Although it would be a normal situation in the construction industry in Europe, the dominance of transportation in the whole production phase is more than 10%, and it is the dominant process in the construction phase (A4-5). In the L'Aquila case, the distance for transporting CLT panels from Austrian manufacturers to the middle of Italy is relatively long, increasing the dominance of this phase up to approximately 12%. In the Joensuu Elli case, as mentioned before, the transportation process accounts for more than 20% of the whole. From these results, it is understood that the environmental impact of the transportation process is relevant and mitigation of this impact may have a higher priority than the actual construction work (A5) involving wooden building elements.

Normally, loadage is optimized for economical reasons. However, the transportation distance is not always proportionate to the price of a construction product. Therefore, sometimes a product is purchased from a distant country because of a cheaper price, even though the same product was available in a neighbouring city. In order to mitigate the carbon footprint of a building, it is significant to consider not only the cost, but also the transportation distance and environmental impact of manufacturing a product that will be delivered for a building construction. From an environmental point of view, it is naturally the worst case to import high impact products due to (for instance) inefficient manufacturing technology from afar because of a low price.

Data collection of this phase would be relatively simple. The required information is a combination of deliverables, transportation distance and vehicle type. Since the dominance of this phase is relatively high compared to the other process in module A4-5, detailed data collection and assessment shall be required. A transparent description of the process is important to lead the optimization of environmental impact.

6.3.6 Waste management

As shown in figures F.6.3-1 to F.6.3-3, the environmental impact from the management of construction waste is minor. However, this phase is important especially for wood construction because of the energy recovery from wood residues.

For instance, based on the amount of wood residue from prefabrication of the Mietraching building, approximately 200,000 MJ of heat energy could be generated, which could cover roughly one-third of the monthly space heating energy for the factory. In short, wood process residue is not waste, but an energy resource. Proper waste sorting is important to enhance the efficiency of waste reuse.

For the assessment of waste management, the required information is the type of waste, its amount and management method (recycle, landfill, etc.), and transport of those wastes. Basically this information is easily obtained. But it is difficult to collect the accurate data regarding waste amount from a specific project, since waste is collected in a container according to a sort from several projects. Detailed data collection may be required when an accurate LCA needs to be conducted in order to optimize the process. But an average number would be helpful for LCA in general.

6.3.7 Prefabrication vs. on-site construction

Although an environmental profile of different construction methods would be of interest for stakeholders from industry and government, there have been only a few scientific research studies this topic [10]. As an example, Quale et al. [10] compared the environmental impact of a modular construction system (prefabrication) and a conventional on-site construction system.

They collected needed information for assessing the construction process of a modular system from three residential modular companies, and based on that, made assumptions with five experienced professional homebuilders when the modular house is constructed on-site. The result shows an average of about 1.5 times more GHG emissions in the case of the on-site construction. However, there is also significant variation within each and some uncertainty in the calculation.

In order to tackle this topic, a tentative study was conducted. Referring the Mietraching building, a prefabrication-oriented construction system and an on-site oriented construction system are compared. Since the construction of Mietraching is highly prefabricated, the original data is used for the assessment of the prefabrication-oriented system. For the assessment of the on-site oriented system, the possible construction duration, number of workers, on-site construction machines and its working ratio, construction waste factor, and waste management method are assumed, based on the original data, literature, and interview with the builder.

Figures F.6.3-11 and F.6.3-12 show the difference between the prefabrication-oriented system and the on-site oriented system regarding primary energy consumption and GHG emissions for the material production and construction phase of Mietraching. Normally, on-site construction work generates more waste than prefabrication, which means more building components are required for the on-site oriented system. This difference appeared in module A1-3, A4, and waste management.

In module A5: Prefabrication and module A5: On-site, the on-site oriented system shows a bigger impact than the prefabrication system. In the prefabrication process, the dominant energy resource is electricity. On the other hand, diesel is the main energy resource in on-site construction in this case. This study shows a result similarly shown in the literature [9]. Naturally it is impossible to conclude something from this study alone. However, from this result

and the literature, it could be assumed that prefabrication is a more efficient construction method for environmental impact as well.

It is also assumed that the environmental profile of construction work is case-specific and affected by several parameters, such as location of the factory and construction site, size and facilities of the factory, and work efficiency of the builder. The construction work is not standardized as the material production process. Further research is required in order to clarify the features of different construction systems with a number of case studies.

Regarding waste management, most waste from on-site construction is regarded as non-recyclable due to the inclusion of impurities. This would be one of the most critical differences between prefabrication and on-site construction. Especially when a benefit from construction waste is taken into consideration, the recyclability of construction waste would make a significant difference, as shown the example in Figure F.6.3-14. This comparison is based on the assumption that wood residue from the prefabrication process is fully recyclable, and 90% of the residue from on-site construction is regarded as non-recyclable waste and just disposed. Although this is an extreme simulation and varies case by case, it is clear that contriving to reduce the amount of waste and to raise the recyclability of waste needs to be considered, especially for on-site construction.

F.6.3-11

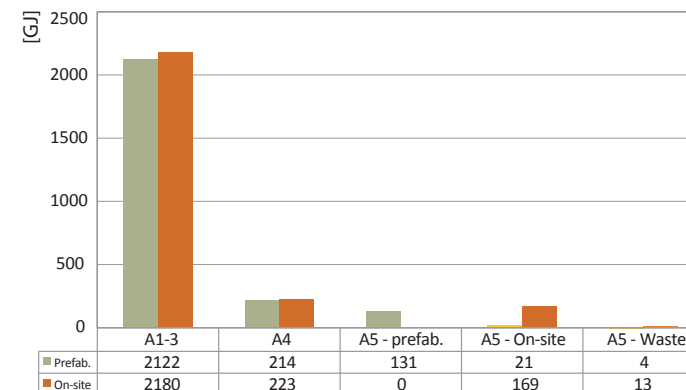

F.6.3-12

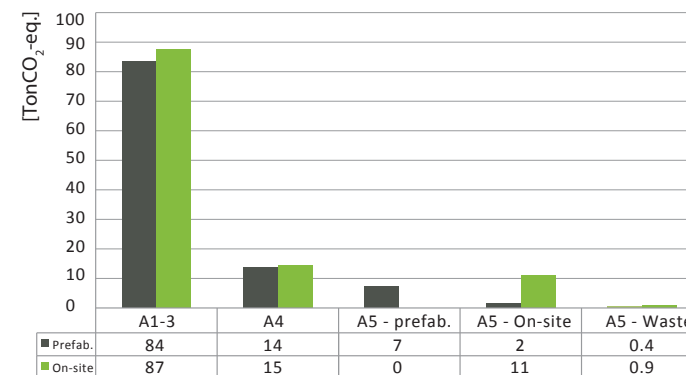

F.6.3-11 Tentative comparison of prefabrication oriented construction and on-site oriented construction regarding primary energy consumption during module A1-5 based on the case of Mietraching

F.6.3-12 Tentative comparison of prefabrication oriented construction and on-site oriented construction regarding GHG emission during module A1-5 based on the case of Mietraching



F.6.3-13 Progetto C.A.S.E, construction site, L'Aquila, Italy

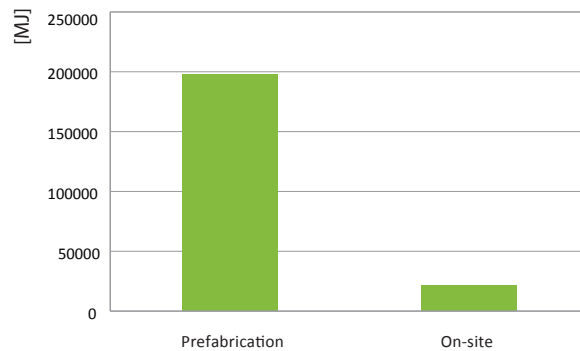

F.6.3-14 Tentative comparison of energy recovery capacity from wood residues generated from the two different construction systems in Mietraching

- Discussion in this chapter is only related to the construction phase of wooden building elements.
- Construction phase seems have minor environmental impact, but it is important to mitigate that at the industrial level.
- Transportation of building components and prefabricated building element has relevant impact.
- Reduction of electricity use during prefabrication process and of diesel use during on-site work is good starting point.
- Prefabrication seems be a more environmental efficient construction way compared to the on-site work
- Further research is required to develop practical and reliable assessment tool for construction work



F.6.4-1 Interior of the Villa Karlsson, Tidö-Lindö, Sweden
 F.6.4-2 Primary energy consumption per m² of living area for different analyzed case studies [2].

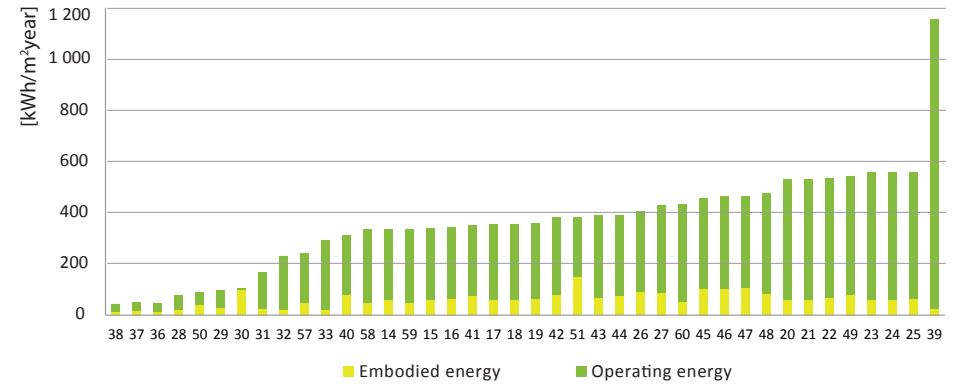

6.4 Use and maintenance

E. De Angelis, F. Pittau, G. Zanata

In this chapter, the environmental impact from the use and maintenance phase (module B) is faced through case studies and literatures. The aim is to give practical recommendations in order to decrease as much as possible the environmental impacts in terms of GHG emissions of the building from this phase. Moreover, an overview of the relationship between this stage and the production and construction stage (module A) is conducted to clarify which kind of actions could be considered in order to avoid the simple shift of an impact from one phase to another.

6.4.1 Introduction

As shown in Section 6.1 (Figure 6.1-1), in the analysis of the life cycle of a building, the use and maintenance phase is normally the most relevant, mainly due to the long timeframe involved and the great amount of operational energy of building. This share can be optimized by increasing the energy efficiency of the envelope toward the new standard for Net-ZEB, aimed by the EU for the year 2020. Often, the actual service life of a building is not easily predicted, and this difficulty sets great limits to

the assessment. According to EN 15978, activities in module B2-5 should include: B2 (maintenance, e.g. cleaning, painting), B3 (repairs), B4 (periodic component replacements), and B5 (refurbishments and renovations), and also B6 (energy use for operation, e.g. heating, cooling, ventilation), B1 (energy use for domestic activities, e.g. cooking, ironing, and washing) and B7 (energy use for operational water).

The need to reduce the energy consumption is due both to the difficulty in energy supply (Europe depends mainly on the rest of the world for its energy supply) and to pollution caused by fossil fuels. Reducing GHG emissions throughout the life cycle means making conscious design choices regarding the materials, construction techniques and equipment. The selection of materials with high durability and reliability may eventually control the risk of failure, and consequently decrease the amount of maintenance and replacements necessary to ensure the functionality of the building in its life cycle. In these terms, sustainability is also strictly linked to the service life of the building and its components. LCA facilitates understanding of whether the benefits from an activity compensate the environmental impact generated from the new inputs (resource consumption, GHG emissions, and waste production). In the use phase, several factors overlap: technological choices made upstream by the designer, the attention of the building occupants

to properly manage the building in relation to the expected service life, and the possible functional and technological renovations. If, on one hand, proper maintenance allows an increase in the materials' service life by decreasing the number of replacements, on the other hand, the increasing required standard quality of a building element over time pushes the introduction in the building system of new products and new technologies in a different lifetime. The rapid evolution of technology (which leads to technical solutions with higher energy efficiency, e.g. higher efficiency and better performing doors, windows and installations) or the need for flexible buildings that require rapid changes in their use, involves the designers in considering proper strategies to simplify as much as possible renovation and replacement activities. In these terms, the use of BIM software may help to properly manage at the same time several critical issues connected to LCA. In fact, BIMs are able to create a single information node that simplifies updates and synchronisation mechanism among the actors of the same construction project. As a consequence, quantities or values stored in these properties can be extracted and reused as the source of information to perform calculations, analyses or simulations in order to define the best design and management strategies. TES EnergyFacade is a practical example of the potential of BIMs in the renovation for the improvement of the energy efficiency

of the envelope of the existing building stock through the use of prefabricated timber modules. [1]

6.4.2 Influence of use and maintenance phase

As reported in Figure F.6.4-2, a recent study conducted on life cycle energy analysis of different conventional houses found that the operating energy in some cases may influence the energy balance up to 90–95%, accounting only for the energy amount for heating and the energy needs for materials production. [2]

On the contrary, when the energy performance of the building increases (high insulation of the building envelope and high efficiency of the heating system and ventilation), the influence of the production phase (A1-3) rises significantly, up to 60% of the overall energy need.

Figure F.6.4-2 compares the dominance of the production and construction phase (module A) with the use and maintenance phase (module B) for the L'Aquila building. As shown, the use phase (B6) accounts for a relevant share of the GHG fossil emissions (65%), while maintenance, repairs, replacement and refurbishment (B2-5) have a marginal influence (9%). The production phase (module A1-3) accounts for approximately 22% of total GHG emissions, while the construction phase (A4-5), in this case, accounts for only 4%.

These results indicate that the use phase (module B) accounts for approx. more than three-fifths and the production and construction phase (module B) accounts for approx. two-fifths of GHG emissions. Notice that for the L'Aquila building, the specific PE need for heating is roughly 43 kWh/m² per year, and the different performance of the envelope and services can significantly influence the results and the percentages.

6.4.3 Use and operational energy need and related GHG emissions

The greatest share of energy consumption of a building during this phase is normally given by heating and cooling systems and by the use of equipment needed for daily activities at home.

The efficiency of the appliances and their use over time significantly influence the annual energy balance. Figure F.6.4-3 shows the average dominance of the different electricity use in the residential sector in Europe (EU-15). In particular, electric heating systems, water use, lighting, refrigerators and freezers can contribute a significant share of primary energy consumption.

Unfortunately, it is impossible to assume that an appliance is properly used in a specific case because the use depends on the habits of the occupants. Recent studies demonstrate how the use of electric and electronic appliances (TVs, microwaves ovens, refrigerators, laptops, PCs, hot water boilers, etc.) contribute to a significant share of the total energy use in dwellings. In particular, recent studies in the UK show that almost 10% of the annual electricity need (roughly £50-90 per year) is consumed while in stand-by mode when the occupants are not using the appliance [3]. In order to save energy, some important indications can be gathered through the monitoring of the actual electricity and fossil fuel consumption in homes. This would enable control over the real efficiency of the appliances in time and their use, and, eventually the most energy consumer appliances can be replaced, once the technology introduces more efficient products on the market.

Particularly, demotic systems can give a very positive contribution in monitoring and saving energy, modifying the set-up of the system in case of anomalies and significantly decreasing the influence of the human factor.

6.4.4 Maintenance and renovations

Maintenance and material replacement (B2-5) can have a significant effect on the life cycle of a building, and their impact can vary substantially, based on materials function. Therefore, they generally have to be included in LCA studies. Timber structures can have a life span of more than 50 years and basically no substitution need regardless of the structural system considered. However, different exterior or interior surface materials and some other building parts may have significantly different service lives or maintenance requirements.

F.6.4-3

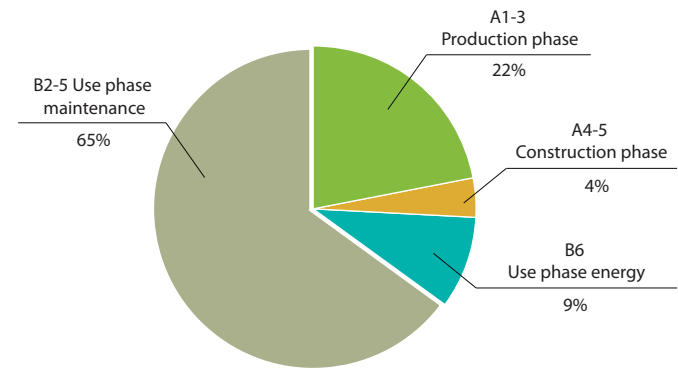

F.6.4-4

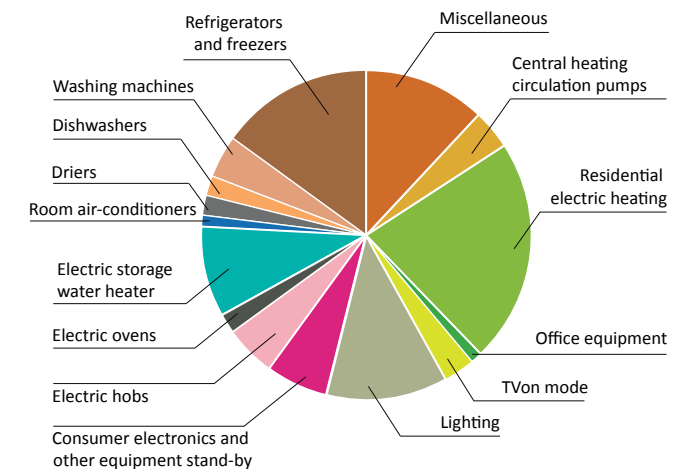

F.6.4-3 Relative dominance of use and maintenance phase in the L'Aquila building (GHG fossil emission).

F.6.4-4 Breakdown of electricity consumption among residential end-use equipment in the EU-15 from 2006 [6].

F.6.4-5

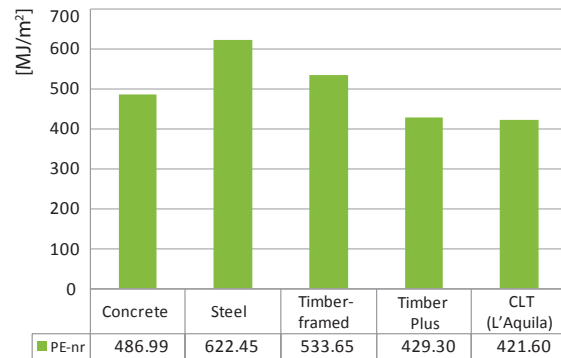

F.6.4-6

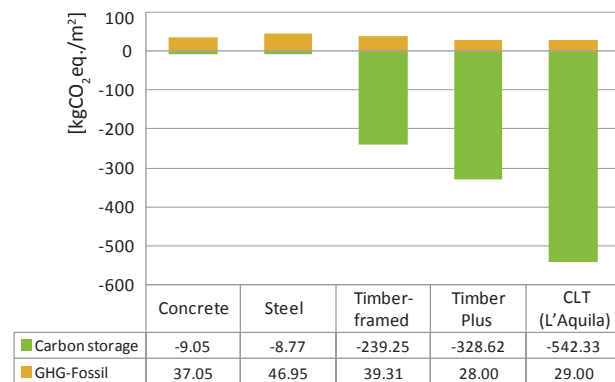

F.6.4-5 Non-renewable primary energy consumption for maintenance. Three alternative materials considered: concrete, steel and wood

F.6.4-6 GHG-fossil emission for maintenance. Three alternative materials considered: concrete, steel and wood.

On the basis of the energy efficiency standard of the building, retrofitting to a higher energy efficiency standard may provide significant benefits in terms of energy and CO₂ saving in the life cycle. Often, there is a great potential by improving energy efficiency in a large share of existing apartment buildings. Most studies on building energy retrofitting have focused on the final energy use during the operation phase of buildings. Fewer studies (e.g., the TES EnergyFacade Project [1]) have analyzed the life cycle primary energy implications of building energy retrofitting. In any case, the interaction between individual measures and the energy supply system needs to be carefully considered. In fact, the primary energy savings for the different energy efficiency measures depend on the energy supply system. Unfortunately, any actual prediction of the evolution of technologies for energy supply and the future energy strategies for each European country makes the effectiveness of the assessment very difficult to achieve.

In order to show the differences in terms of GHG fossil emissions and the non-renewable energy consumption of different materials, the results from an analysis of the impacts from the maintenance phase in the L'Aquila case study is shown comparing three alternative materials: concrete, steel and wood (timber-framed and CLT-based structures). The comparative calculation is made on the base of a tertiary building in New Zealand made of a timber-framed structure (press-lam) [4]. Then the results are compared with other representative residential building in L'Aquila made of CLT panels.

Figure F.6.4-5 shows the non-renewable PE consumed for each alternative for maintenance. In the analysis, some activities are taken into account: periodical cleaning, painting, checking and inspections, and partial substitution of some damaged parts per m² of living area. From these studies, increasing the use of wood in the structure (timber, plus it is still timber-framed but with a greater content of wood in finishing and cladding) leads to a decrease in the PE non-renewables used for this phase of the building's life cycle.

Similarly, Figure F.6.4-6 represents the relative amount of fossil carbon emission for each alternative structure. As shown in the figure, increasing the use of wood allows the storage of a great amount of carbon in timber products, with a positive effect on

the environment in terms of carbon sequestration from the atmosphere. In both figures, steel results in the highest share of impact, mainly due to the superficial treatment to be restored periodically where the structural and non-structural elements are exposed. The estimated service life of the building normally may affect the result significantly. As shown in Figure F.6.4-8, the GHG emissions from maintenance and substitutions of material increase linearly over time for the L'Aquila building. Nevertheless, the reference service life of building products still remains very difficult to assume, mainly due to the lack of specific and validated databases.

Building elements

Considering the L'Aquila case study, it should be noted that wood does not undergo any degradation or decay of the mechanical properties over time, but it can be strongly subjected to biological degradation by fungi and xylophagous insects. For this reason, the life span of wood products is strongly influenced by the conditions of combined moisture exposure and temperature, conditions which may require careful maintenance. See Chapter 7: Service life and moisture safety.

The correct design of wood-based components is essential in order to avoid a premature degradation caused by an insufficient drainage of rainwater from critical surfaces. The ventilation allows the exportation of moisture and contributes effectively to keep the wooden surfaces dry. Moreover, a correct evaluation of the hygrothermal conditions of the timber structures in the critical seasons is strongly needed in order to choose the most effective airtightness. For this reason, more than for other alternative structures, it is important that the designers have valid know-how about good design practice in order to manage the most critical details of the construction.

Generally, the application of woodworm products, as well as fungicides or other preservative treatments, according to DIN 68800 and the European standard, is not allowed. Constructive wood protection must be considered first, and preservatives are allowed only if absolutely necessary. The use of these kinds of products for maintenance implies on the one hand the reduction of

replacements, avoiding the consumption of natural resources and the emission of waste in the environment, but on the other hand the use of protective products with a significant environmental impact. As pointed out in an article by Werner and Nebel [5], the auxiliary products for maintenance of wood adversely affect the environmental impacts generated by the use of wood as a building material.

Unfortunately, some critical parts of timber components are placed in the internal part of the structure, and their operating status is impossible to check without an invasive inspection. For this reason, the use of humidity and temperature sensors in the most critical parts of the building (e.g., the connection between basement-foundations/external walls, windows/walls, roof/walls, etc.) should be adopted in order to ensure the best operative conditions in time, avoiding mould growth and degradation. A periodic check of the superficial temperature of the external/internal surfaces of the structures through the use of a thermographic camera allows one to qualitatively evaluate the operative conditions of the structures and see eventual increments of moisture content.

HVAC systems

Currently, not enough information on the environmental impact related to the maintenance of HVAC systems is available for an exhaustive LCA on buildings. EPDs are normally still rare for these kinds of systems, and if available, they do not include module B in the assessment. According to EN 15804, only module A1-3 is mandatory. Nevertheless, their influence in terms of GHG emissions in the use and maintenance phase could be significant. Especially for those systems containing liquids such as R22, R422d, R134a, R407c and R404 (normally used in machines for heating and/or cooling) could lead to a great impact in terms of GHG emissions. Nowadays, a new generation of liquids (e.g., R R410A, regenerated R22 or R422d) have a reduced impact on the global warming potential, so they are much more ecological than other liquids. Thus, the use of products and machines that adopt these liquids is strictly recommended in order to reduce their impact over time.

6.4.5 Recommendations

On the basis of the achieved results, the following conclusions can be summarized:

- The use and maintenance phase (module B) is in most of the cases still the most relevant phase in terms of the GHG emissions of a building. A share between 15% (low-energy houses) and 95% (conventional houses) is related to the energy spent for operational use and maintenance. The decrease of this share affects the impact from the production phase (module A). Thus, an optimization of the thermal performance of the building, according to the new in the boundaries of the assessment can give a valid contribution EU directive on energy efficiency, and a careful selection of the used materials is strictly needed;
- Occupants' habits and their appliance use during the use phase (B1) affect the results significantly. The mean European values or national consumption values for a "typical family" for each country may be assumed for the assessment of dwellings. Monitoring the actual electricity and fossil fuel consumption in homes allows control of the real efficiency of the appliances and their correct use. Especially home automation systems can be able to save a great share of energy, even if the education of the occupants in the use of the building still plays a fundamental role.
- Maintenance and material replacement activities have a significant effect on the life cycle of a building. The actual life span of the various materials is very difficult to estimate, mainly due to the lack of specific data. For the primary structure, normally the same life span of the building can be assumed, and different exterior or interior surface materials and some other building materials may have significant differences in terms of service life.
- The life span of wood products and the maintenance needed to preserve the functionality over time is strongly influenced by moisture content and temperature. The auxiliary products for maintenance of wood negatively affect the environmental

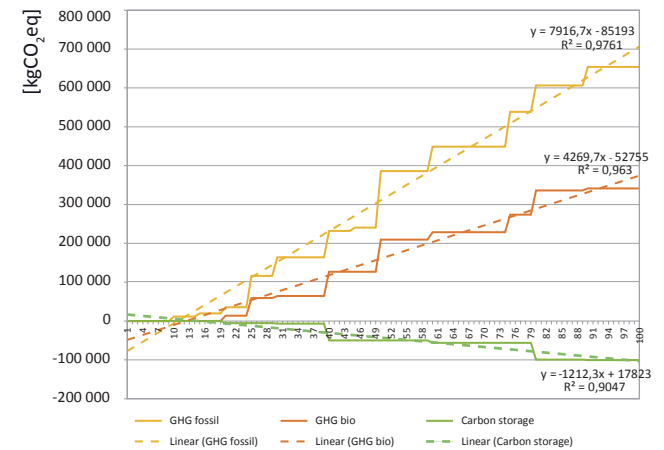

F.6.4-7 GHG fossil and biogenic emission and carbon storage over the time for maintenance (module B2) and replacement (B4) activities, L'Aquila building. The RSL of products were assumed from BLP Durability Assessment report [7] considering the k-factorial method for the prediction of the ESLs.

- Use and maintenance phase (mod. B) is, in most of the cases, still the most relevant phase in terms of GHG emission of a building.
- Maintenance and material replacement activities have a significant effect on life cycle of a building.

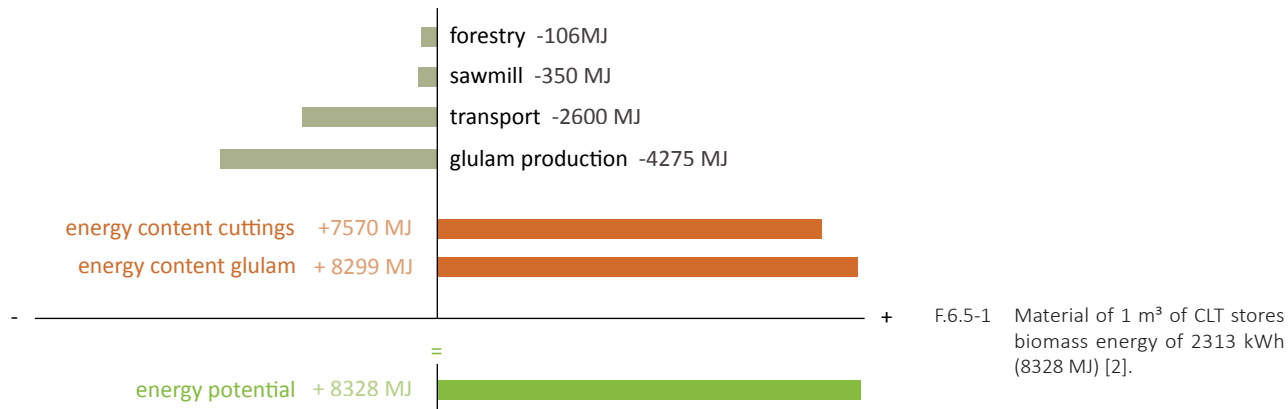
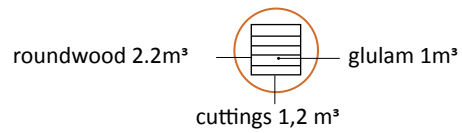

impacts generated by the use of wood as a building material. For this reason, the use of products with available EPDs is strongly recommended. Externally, the correct design of the technological details of wood elements (e.g. drainage, sufficient ventilation, rainwater protection, etc.) may increase the estimated life of the wooden products, decreasing the risk of failure.

- By using humidity and temperature sensors internally, the walls or floors can give a practical contribution in monitoring the physical conditions of the critical points, avoiding the risk of degrading wooden components. Even a periodic check of the temperature through the use of a thermographic camera allows monitoring the operating conditions of the structures.
- HVAC systems and the impact related to maintenance activities are often difficult to assess. Specific EPDs that include module B for an exhaustive LCA on buildings. The periodical substitution of some liquids for refrigeration could lead to a great impact in terms of GHG emissions. The use of products and machines that adopt new generation liquids with more ecological properties is recommended in order to reduce the overall impact over time.

6.5 Deconstruction and recycling, end-of-life

A. Hafner, S. Ott, S. Winter

6.5.1 General

Various papers have discussed the importance of the end-of-life phase for wood. For information on holistic understanding of this phase in the context of global considerations, see Chapter 3. This research project was mainly focused on the production phase and in parts on the use phase of buildings. Therefore, no detailed process recommendations and guidelines have been worked out yet for the end-of-life phase. This chapter shows general considerations on the end-of-life phase in relation to the use of wood. They are limited to the system of the practical LCA of buildings.

Deconstruction of a building, demolition and end-of-life scenarios are to be integrated in full LCA calculations. In the standards of EN 15804:2012 and EN 15978:2011, these phases are part of module C. Modules include deconstruction/demolition (C1), transport to the product's waste processing (C2), waste processing for reuse, recovery or recycling, recovery and/or disposal (C3), disposal (C4); "including all transports, provision of all materials, products and

energy, during the end-of-Life stage up to end of waste stage or final disposal." [1]

To show the possible benefits and loads of materials beyond the product system boundary, a separate module D is also introduced. This means that in module D the recycling potential, the persistence of mineral building products, embedded renewable energy or carbon stored in the product can be shown. According to the standards, all benefits have to be separately shown in module D. This brings transparency to the calculations and helps to comprehend the included benefits and loads from the end-of-life scenarios modelled in the study.

Up to now for all wooden products, the end-of-life scenarios have consisted almost only in incineration and therefore energy recovery. The benefit of recovered energy then has to be shown in module D. With energy recovery, the energy content in wooden products then gets used and greenhouse gases are thereby emitted. The carbon stored in the product over the lifetime is released.

By growing trees in the forest, carbon gets stored in the material. Greenhouse gas emissions have a negative or minimal positive value in module A due to the carbon stored in the product. Here, calculations must sum up negative greenhouse gases (carbon

storage) and emitted GHG during the production process. At the end-of-life, wooden material gets burned, so GHGs are emitted. Several LCA calculations regard wood as GHG-neutral.

This is only the case if calculations include the whole life cycle from production to end-of-life if the wood is not leaving the forest system and if these forests are not being harvested. LCA calculations done according to the standards of EN 15804 and EN 15978 do not give instructions for the handling of wood and sequestration of carbon. But according to these standards, the carbon and primary energy have to be accounted for separately in the different modules. This requires that the carbon balance is shown divided up in the modules. Hence wooden materials become a negative value in module A1 and a positive value in module C4, as can be seen in Figure F.6.5-1. Energy gains and the carbon stored in the product (if it is reused or recycled) have to be shown in module D. The overall carbon balance is still zero, but it can be divided among the different modules.

C1 – deconstruction and demolition

- *Starting point:* Building is not used anymore and will be demolished.
- *Content:* The building is replaced, dismantled and deconstructed. Includes all energy / emissions needed for deconstruction, demolition on site and for the general division in different fractions.
- *End:* Building is divided into different fractions according to European waste categories.
- *Role of wood:* The energy content / carbon stored in the wooden material still exists; material has its own backpack of emissions due to the product stage A to C1; a possible carbon credit can be accounted for in module D.

C2 – transport

- *Starting point:* The material input is sorted from the building in different fractions from C1.

- *Content:* All transport from the site to intermediate storage facilities and all transport to final disposal. If material is reused or recycled, the transport to the recycling plant is included (end = gate of plant). If material reaches its “end-of-waste” status, it is treated with all its burdens as a raw material supply (A1). For materials that leave the system as secondary material, stages C1 and C2 have to be calculated as end-of-life for the original product.
- *End:* Waste processing plant (recycling plant) or disposal is reached.
- *Role of wood:* energy content / carbon stored in the wooden material still exists; material has its own backpack of emissions due to the product stages A, C1 and C2; a possible carbon credit can be accounted for in module D.

C3 - waste processing

- *Starting point:* Building material fractions passing the gate of the waste processing plant.
- *Content:* This phase includes all processes that are necessary for reuse, recycling or energy recovery. “Waste processing shall be modelled and the elementary flows be included in the inventory.” [1, page 24]
- *End:* The material has reached the “end-of-waste” stage and is transferred to the product stage as secondary material.
- *Role of wood:* The energy content and carbon stored in the wooden material still exists; the material has its own backpack of emissions due to product stage A, C1, C2 and C3; a possible carbon credit can be counted in module D.

C4 – disposal

- *Starting point:* Final disposal or landfilling; includes all emissions.

“potential loads, (e.g. emissions) from waste processing in module C4 are considered part of the product system under study, according to the “polluter pays principle”. If however this waste processing gives rise to secondary fuels with an efficiency rate of <60% (and in institutions built after Dec. 31, 2008 <65%) such as heat and power from waste incineration or landfill gases, the potential benefits from the use of such secondary fuels in the next product system are assigned to module D and are calculated using current average substitution processes.” [1, page 24]

- *Role of wood:* Wooden material is burned, the embodied energy is used, the stored carbon is now zero, and the heating value can be assigned in module D.

D – Additional information

Module D is for information only and brings transparency to the benefits and burdens and the assumed scenarios. “When relevant, the informative module D is used to declare potential loads and benefits of secondary material or secondary fuel leaving the product system. Module D introduces the “design for reuse and recycling” concept for buildings by indicating the potential benefits of avoided future use of primary materials and fuels, while taking into account the loads associated with the recycling and recovery processes beyond the system boundary. Where a secondary material or fuel crosses the system boundary e.g. at the “end-of-life” stage and if it substitutes another material or fuel in the following product system, the potential benefits or avoided loads can be calculated based on a specified scenario which is consistent with any other scenario for waste management and is based on current average technology or practice.” [1, page 29]

- *Starting point:* All declared benefits and burdens that have left the system boundary during stages A to C. This includes, for example, residues used as energy source, energy created by burning wood at end-of-life or carbon stored in a product for secondary use.

Possible categories (Wood)

- PE ren: Renewable primary energy for material use (in MJ). It is assumed that the material can replace (substitute) fresh wood. The material has reached the “end-of-waste” stage in module C3, reaching the point where it can replace other wooden raw material as input for wooden products.
- PE ree: Renewable primary energy for energetic use (in MJ). Here, the part of wooden material used for energy recovery is calculated.
- Sm: Secondary material (kg). This shows the amount of recycled material used as secondary in the production process used.
- MFR: Material for recycling (m³). This shows the amount of material which is usable for recycling, and should correspond with the energetic value in PE rem.
- MER: material energetic recovery (m³). This shows the amount of material that is usable for energetic recovery, and should correspond with the energetic value in PE ree.
- CRU: component recycling use (m³). This shows the amount of material that is usable for reuse without further processes.

According to the research report of [3], where life cycle assessment datasets for wooden building products were generated, these categories were outlined and calculated. They can make the possible reuse of wooden products visible and show a realistic division of the waste wood fractions, because not all waste wood is going to thermal recovery.

6.5.2 Legal framework

Material recycling, reuse and energy recovery are theoretically possible as end-of-life scenarios for wooden products. Different end-of-life options are useful for different cases. To explore these options, some general frameworks have to be shown, and then the different options are discussed.

Resource-efficient Europe Initiative

The aim is to increase resource efficiency by reducing the use of raw materials and lower CO₂ emissions. This reflects on building material and here also on recycling and reuse. [4]

Waste hierarchy

According to the EU Directive on waste [5], there is a waste hierarchy, which shall apply as a priority order to all material in waste prevention.

The EU directives as well as the national laws in many European countries aim at higher rate of reuse and recycling, which leads to reduced amounts of wastes to be landfilled. The basic principle in the European waste management directive is that materials should be primarily recovered for secondary use, and only as a secondary option, they can be utilized as energy. Landfill for wooden products is currently not allowed in Germany and other EU countries. Most probably energy recovery will not be regarded as recycling in the coming future.

For practical reuse, a classification of used wood is necessary. The aim must be to avoid bringing wood with preservatives back to recycling. As an example, four classification divisions in waste wood (German waste wood scenarios) are shown. The used wood is divided up into four categories in order to decide which wooden material is usable for which waste scenario,

a) Waste wood category A I:

Waste wood in its natural state or only mechanically worked that during use was at most insignificantly contaminated with substances harmful to wood.

b) Waste wood category A II:

Bonded, painted, coated, lacquered or otherwise treated waste wood with no halogenated organic compounds in the coating and no wood preservatives.

F.6.5-2



F.6.5-3



F.6.5-2 Piano pavilion, Lahti, Finland
F.6.5-3 Kierikki-keskus, Oulu, Finland

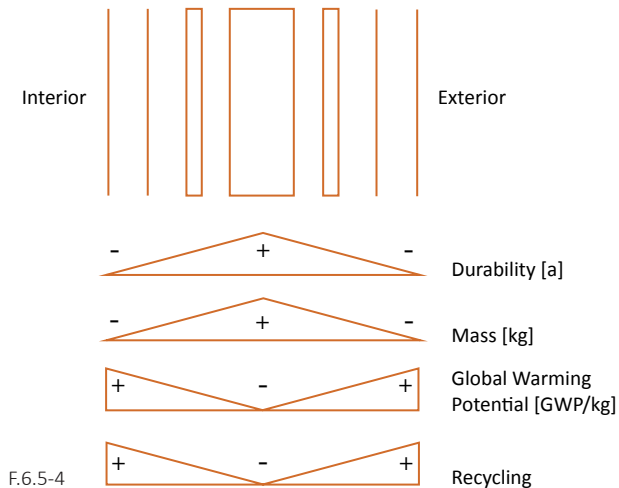

c) Waste wood category A III:

Waste wood with halogenated organic compounds in the coating with no wood preservatives.

d) Waste wood category A IV:

Waste wood treated with wood preservatives, such as railway sleepers, telephone masts, hop poles, vine poles as well as other waste wood which, due to its contamination, cannot be assigned to waste wood categories A I, A II or A III, with the exception of waste wood containing PCBs [6].

According to German laws, the term used wood (Altholz) means used wood from production and end user, as far as it is covered by the German life cycle Resource Management Act. There is also industrial wood, which includes all “manufactured wood products”, wood from massive construction and wooden products with a mass percentage over 50%.

There are various studies (at least in the German market) ([7], [8], [9]), which quantify the usage of wood in market shares. Explicit calculations on recycling of wooden material in the building sector have not yet been done.

C1	C2	C3	C4	D
Deconstruction Demolition	Transport	Waste processing	Disposal	Benefits/loads
				+ -
Emissions from energy used for deconstruction	Emissions to intermediate storage facility and waste processing	Emissions for: <ul style="list-style-type: none"> breaking up wood to chips cutting e.g timber walls to beams 	Incineration --> emissions (GHG)	Energy (heating value)
Carbon storage	Carbon storage	Carbon storage	-	
PE-r	PE-r	PE-r	-	PE-ree

F.6.5-5

F.6.5-4 Sequence of technical and functional layers and weighted influence on the end-of-life impact. [10]

F.6.5-5 Allocation to different modules for energy recovery.

6.5.3 Building description and life cycle

While buildings are seen as a whole in the use phase, for end-of-life, it comes down to the specific construction and the materials they are made of. Building components can be decomposed into different layers to get a deeper understanding of their impact at end of life; compare Figure F.6.5-4. The layers of the building have different exposures, durability and therefore a different life span. In modern (timber) buildings, different layers are also common to fulfil a wide variety of technical requirements. There are technical/constructive layers and functional layers.

Technical layers:

- are part of the load-bearing structure,
- define resource use and material use,
- are relevant for the life span of the building part,
- are made to last for a long time.

Functional layers:

- depend on usage,
- change resource consumption through reuse or recycling,
- are exchanged frequently, depending on exposure

- have to be material efficient
- durability should be chosen according to the usage.

The disassembly allows the identification of required service life of building parts and has to be considered in maintenance, inspection, and end-of-life scenarios. Figure F.6.5-4 shows the different layers of a façade divided in their technical and functional layers. The primary construction needs to outlast the whole life span; wooden primary construction has high mass and can store a large amount of carbon over this period. The other layers (e.g., cladding) will be replaced many times and therefore are relevant in terms of recycling potential and burdens/benefits at the end-of-life stage.

This can be used as design methodology for the improvement of environmental performance. Through the interdependency of use- and end-of-life scenarios, the different layers can be separately optimized more easily and then be designed for reuse. The jointing between layers and the frequency of renewal are additional criteria for the end-of-life phase, apart from the material impact.

C1	C2	C3	A1	D
Deconstruction Demolition	Transport	Waste processing	Raw material	Benefits/loads
				+ -
Emissions from energy used for deconstruction	Emissions to intermediate storage facility and waste processing	Emissions for: • breaking up wood to chip • cutting e.g. timber walls to beams		
Carbon storage	Carbon storage	Carbon storage	Carbon storage	Carbon storage
PE-r	PE-r	Pe-r	-	Pe-rem, Pe-ree, SM, MPR, CRU
1. Life cycle			2. Life cycle	

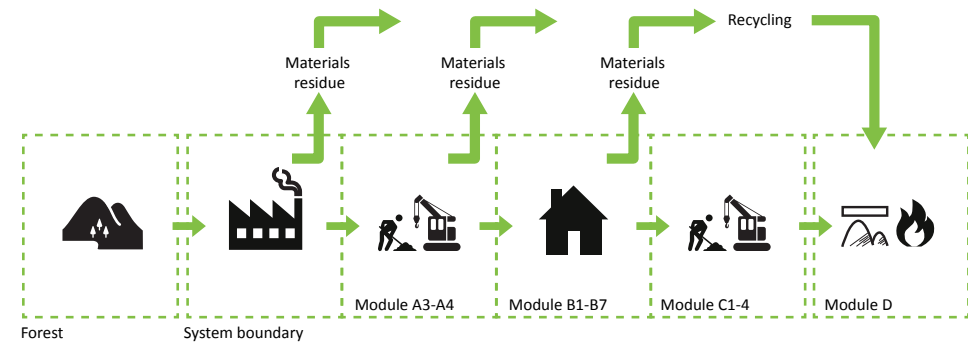

F.6.5-6 (left) Allocation to different modules for material recycling
 F.6.5-7 (right) Residues in the life cycle of buildings according to EN 15804 and EN 15978

6.5.4 Energy recovery

Energy recovery means that the material gets burned in incineration plants. Then the embedded primary energy stored in wooden products gets released and a heating value is generated.

For LCA calculations of buildings, emissions generated in the end-of-life stage also need to be allocated. The deconstruction of the wooden parts in the buildings, the collection in fractions and the shearing into small parts belong to modules C1 to C3. Module C4 contains the incineration process, while all the transport up to the incineration plant belongs to module C2. Module D lists the loads for energetic recovery (greenhouse gases) and states the benefits of usable primary energy.

Incineration with energy recovery is useful for various materials such as:

- Wood contaminated with paint/lacquer;
- Wood contaminated with toxic substances (like PCP, impregnation);
- Small wooden parts which are bound together with glue;
- Other materials that cannot easily be separated.

According to the German used wood categories described previously, energetic recovery is feasible for categories A III to A IV and in parts A II.

Calculations of how much energy is used in the process and how much emissions are generated must be done for the specific analyzed processes. Up to now for LCA calculations, the energetic recovery has been used as the end-of-life scenario for all wooden constructions. Landfilling is not allowed for wooden materials, while the possibilities of cascade use are not researched in detail yet and therefore are not widely applied in calculations. There are no figures existing yet for deconstruction (C1), which is very much dependent on the building site and its surroundings, and for waste processing (C3). The transport (C2) could be calculated for projects knowing the lorry size and distances from the site to the waste processing plant.

6.5.5 Material recycling

“Recycling” means any recovery operation by which waste materials are reprocessed into products, materials or substances; whether it is for its original or new purposes. It includes the reprocessing of organic material but does not include energy recovery and

the reprocessing into materials that are to be used as fuels or for backfilling operations” [5].

Material recycling can only be applied for wooden materials in category A I, and there must be a strict selection process to ensure that no contaminated material gets reused. Up to now the selected material for recycling gets used for softboard production. For example, massive timber construction is deconstructed and recycled by breaking the material into chips for chipboard. The material gets shredded to chips and is mixed with fresh material as input for softboard production only. The results of the usable percentage of recycling material has been worked on in the research project, DEMOWOOD.

A potential use of beams and joists of wide-span structures could be to saw them into parts and reuse them as beams for smaller constructions. Non-reusable materials (e.g. small corners) and residues can be burned, generating heating value.

From a life cycle perspective, this results in a longer period of carbon stored in products and a higher usage of secondary material which then implies less energy and emissions in the production phase A1.

6.5.6 Reuse (with low to no modification)

“‘Re-use’ means any operation by which products or components that are not waste are used again for the same purpose for which they were conceived.” [5]

Reutilization: For example, massive timber construction is deconstructed and reused for the same purpose.

Subsequent use: For example, solid timber construction is deconstructed and then cut into parts to be used as beams for roofing. The compounds are down-cycled but the material still has some of its properties.

This reuse is only useful for wide-span structures and laminated beams that have no material faults. For reuse, it is important that no preventive wood protection is applied to constructions, while for easy deconstruction it is beneficial to screw joints rather than nailing and clipping. This means that recommendations need to be made for design for reuse/recycling.

In general there are various possibilities to extend the life cycle of a product or material:

- Extend the life span of the building and the durability of the products.
- Keep information about an existing building through a building passport (or sustainability certification).
- Maintenance, repair, renewal of surfaces (exterior and interior).
- Modularity of the structural system from components to the structural system.
- Easy dismantling of the buildings (connecting devices).
- Design for reuse.
- Use screws instead of nails, clippings.

- Avoidance of composite materials.
- Avoidance of toxic substances.
- Use of waste wood fractions A I (only in parts A II).

The prefabrication in the wood process is an advantage for durability and the end-of-life phase, whereas the construction has to be designed in modular elements. The replacement of single layers is possible through straight joints, so recycling becomes much easier.

6.5.7 Conclusions

With the growing importance of wood as a significant biomass component of the renewable energy supply, there might be a shortage in the availability of wood in the future. The EU directives [5] and national laws in many European countries aim at a higher rate of re-use and recycling. The basic principle in the European waste management directive is that materials should be primarily recovered for secondary use, and not until a secondary option can they be utilized as energy.

Therefore, the European Commission proposed to increase the efficiency in the production and the use of wood [11] and resource efficiency in general [4]. The overall goal must be to increase the long-term availability of renewable but at the same time limited resources for the wood cluster. The competition for raw materials between stakeholders in the wood cluster will be reduced and the wood utilization with immanent positive effects on climate protection will be optimized. An approach to higher resource efficiency is the implementation of material flow management in the entire process of timber construction.

The European Union has set an objective to develop itself as a recycling society, where waste generation is avoided, and wastes generated are utilized as a resource. The latest waste directive from 2008 [5] contains an article for the re-use and recycling of materials. Among other things, it requires that the member countries have to proceed with necessary actions to recycle materials and products. To fulfil the normative requirements, the

industries and R&D should develop products that can be easily recycled. In the wood product sector, the waste hierarchy is so far largely underdeveloped. A lot of wood products that could be utilized in the secondary product life cycle are burned for energy.

This reduces the competitiveness of wood as a construction material not only from the environmental point of view, but also from the business point of view. On the other hand, it offers an obvious opportunity for innovative companies to create new business models, processes and products [12].

A better management of its renewable resources helps the wood sector to ensure a long-term availability of solid wood products at reasonable prices. This will allow preserving and also gaining market shares now and in the future.

In general, the demand for reclaimed wood products in the building sector will rise due to the fact that the thermal use of wood is the last option in the cascade of use. The preferred option has to be the reuse and the recycling of reclaimed wood. On this option the refinement of reclaimed wood for innovative products as well as the broadening and enhancement of the paths of reuse and recycling is strongly needed for the timber construction industry.

Long-term and a resource-efficient use of wood of premium quality (such as laminated wood, plywood, timber frame construction) is necessary to ensure sustainable construction with wood. In the process of planning wooden construction, the deconstruction, reuse and recycling of the products have to be considered, too.

Further research is needed in the availability of recycling material and also how to detect toxic substances in material for recycling. More research is also necessary in developing data for modules C1 and C3 for wooden products and C4 in general. Actual numbers from 2012 market observations show that the usage of wood for energy reasons has overcome the use of wood for the material use purpose for the first time in Germany. This underlines the necessity to promote reuse and recycling and furthermore, design for recycling in the wood sector.

6.6 Conclusions

Chapter 6 describes the environmental properties of Life Cycle Analysis and the carbon footprint in the life cycle of a building. The aim is to show the basic principles for carbon-efficient wood construction. This is done to improve the environmental performance of buildings. Providing a clear description of the assessment processes and results are fundamental requirements. The underlying fundamentals of the system boundaries for applied practical LCA are described in Section 6.4.2.

First, the general issues of goal setting and the requirements for it are discussed in Section 6.1. The processes of designing low-carbon wooden houses are outlined in Section 6.2. Beside product material, the construction process also has an ecological footprint. We evaluate the influence of the construction phase and compare the prefabrication versus on-site construction process with respect to ecological matters. The influence of transport and waste management are shown in Section 6.3. Then influences of the use and maintenance phase and related issues are discussed in Section 6.4. Finally, the end-of-life stage, deconstruction and recycling, with a focus on wooden material, are considered in Section 6.5.

The results are as follows. Goal setting for carbon-efficient buildings must be done by the owner at a very early stage in the process. A systematic design process needs to be developed so that the building sector can contribute to the reduction of greenhouse gases and primary energy use.

Increasing energy efficiency during the use phase reduces the carbon footprint of this phase. Therefore, the primary energy consumption resulting from construction comes into focus. Generic data is used for making calculations during the design stages, whereas specific data is required for calculations done for real buildings.

The construction phase itself seems to have a minor environmental impact in comparison to the material side of operations, but it is still important to mitigate the impacts at the industrial level. The transportation of building components and prefabricated building



F.6.6 Construction site, L'Aquila building, Italy

elements has a relevant impact. Prefabrication (off-site construction) seems to be a more environmentally efficient way of building compared to on-site work.

Further research is required to develop a practical and reliable assessment tool for construction work. Our discussion is only related to the production and construction phases of wooden building elements.

The use and maintenance phases (mod. B) are in most of the cases still the most relevant phases in terms of the GHG emissions of a

building. Maintenance and material replacement activities have a significant effect on the durability of a building.

The long-term and resource-efficient use of premium-quality wood (such as laminated wood, plywood, timber frame construction) is necessary to ensure sustainable construction when using wood. During the process of planning a wooden construction, the deconstruction, reuse and recycling of products must be considered as well.

REFERENCES

6.1 Goal setting and requirements

- [1] Hafner, A., Winter, S. and Takano, A., 2012. Wooden products as building material in life cycle analysis. In: Proceedings of the Third International Symposium on Life-Cycle Civil Engineering. Vienna: Taylor & Francis Group, pp. 1530-1537.

6.3 Construction

- [1] Verbeeck, G. and Hens, H., 2007. Life cycle optimization of extremely low-energy buildings. Helsinki: Clima 2007 WellBeing Indoors. Helsinki, Finland.
- [2] Scheurer, C., Keoleian, G.A. and Reppe, P., 2003. Life cycle energy and environmental performance of a new university building: modelling challenges and design implications. *Energy and Buildings* 35, pp.1049–1064.
- [3] Junnila, S. and Horvath, A., 2003. Life-cycle environmental effects of an office building. *J. Infrastruct. Syst.* 9-4, pp.157–166.
- [4] Junnila, S., Horvath, A. and Guggemos, A., 2006. Life-cycle assessment of office buildings in Europe and the United States. *J. Infrastruct. Syst.* 12-1, pp.10–17.
- [5] Guggemos, A. and Horvath, A., 2005. Comparison of environmental effects of steel- and concrete-framed buildings. *J. Infrastruct. Syst.* 11-2, pp.93–101.
- [6] Guggemos, A. and Horvath, A., 2006. Decision-Support Tool for Assessing the Environmental Effects of Constructing Commercial Buildings. *Journal of Architectural Engineering* 12, pp. 187-195.
- [7] Peña–Mora, F., Ahn, C., Golparvar, F.M., Hajibabai, F., Shiftehfar, S., An, S., Aziz, Z. and Song A., 2009. A framework for managing emissions during construction. *NSF International Workshop on Green Buildings and Sustainable Construction*, Cairo, Egypt.
- [8] Ahn, C., Rekapalli, P., Martinez, J. and Peña-Mora F., 2009. Sustainability analysis of earthmoving operations. Austin, TX: IEEE Winter Simulation Conference.
- [9] Quale, J., Eckelman, M.J., Williams, K.W., Sloditskie, G. and Zimmerman J.B., 2012. Comparing environmental impacts of building modular and conventional homes in the United States. *Journal of Industrial Ecology*, 16(2), pp.243-253.
- [10] Orabi, W., Asce, M., Zhu, Y., Asce, A.M. and Ozcan-Deniz, G., 2012. Minimizing Greenhouse Gas Emission from Construction Activities and Processes. *Construction*

F.6.7 Student housing in Kista, Sweden

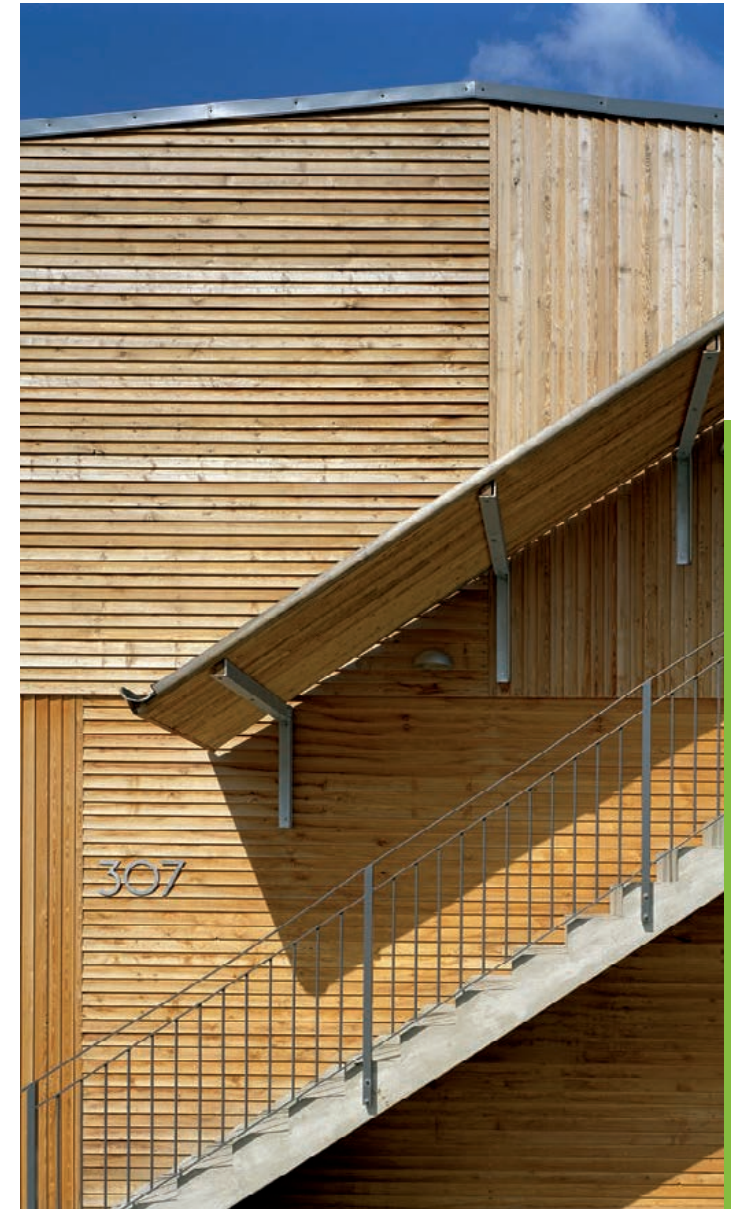

Research Congress 2012, American Society of Civil Engineers, pp.1859-1868.

6.4 Use and maintenance

- [1] TES EnergyFacade Project, 2012. [online] Available at: <<http://www.tesenergyfacade.com>> [Accessed 8 March 2013].
- [2] Sartori, I. and Hestnes, A.G., 2007. Energy use in the life cycle of conventional and low-energy buildings: a review article. *Energy and Buildings*, 39(3), pp.249-257.
- [3] Energy Saving trust, 2013. Standby: the energy that no one uses. [online] Available at: <<http://www.energysavingtrust.org.uk>> [Accessed 8 March 2013].
- [4] John, S., Nebel, B., Perez N. and Buchanan, A., 2009. Environmental impacts of multi-storey buildings using different construction materials, Research Report 2008-02. University of Canterbury, New Zealand. [online] Available at: <<http://www.maf.govt.nz/forestry/publicationp/lca-materials.pdf>> [Accessed 16 December 2012].
- [5] Werner, F. and Nebel, B., 2007. Wood & Other Renewable Resources. *International Journal of LCA*, 12 (7), pp. 462-463.
- [6] Bertoldi, P. and Atanasiu, B., 2007. Electricity consumption and efficiency trends in the enlarged European Union, Status Report 2006., Ispra, Italy: Institute for Environment and Sustainability.
- [7] Building LifePlans, 2005. BLP Durability Assessment. London: BLP.

6.5 Deconstruction and recycling, end-of-life

- [1] EN 15804:2012 Sustainability of construction works – environmental product declarations – core rules for product category of construction products.
- [2] Holzforschung, München, and TU, München., 2010. „Bauen mit Holz = aktiver Klimaschutz“. [pdf] Munich: Cluster

Forst und Holz Bayern. Available at: <<http://www.cluster-forstholzbayern.de/images/stories/downloads/broschuere/broschuere-bauen-mit-holz-klimaschutz.pdf>> [Accessed 30 November 2012].

- [3] Rueter, S. and Diederichs, S., 2012. Ökobilanz-Basisdaten für Bauprodukte aus Holz. Arbeitsbericht vTI Nr.2012/1. [pdf] Hamburg: Johann Heinrich von Thünen-Institut. Available at: <http://www.holzundklima.de/projekte/oekobilanzen-holz/docs/Rueter-Diederichs_2012_OekoHolzBauDat.pdf> [Accessed 12 December 2012].
- [4] Directive 2008/98/EC of the European Parliament and of the Council of 19 November 2008 on waste and repealing certain Directives. Official Journal L 312 , 22/11/2008 P. 0003 – 0030. [pdf] Available at: <<http://eur-lex.europa.eu/LexUriServ/LexUriServ.do?uri=OJ:L:2008:312:0003:01:EN:HTML>> [Accessed 16 July 2012].
- [5] Lang, A., 2004. Charakterisierung des Altholzaufkommens in Deutschland. Rechtliche Rahmenbedingungen - Mengenpotenzial – Materialkennwerte. In: Mitteilungen der Bundesforschungsanstalt für Forst- und Holzwirtschaft Nr. 215. Hamburg: Kommissionsverlag Buchhandlung Max Wiedebusch.
- [6] Weimar, H., 2009. Empirische Erhebungen im Holzrohstoffmarkt am Beispiel der neuen Sektoren Altholz und Großfeuerungsanlagen. Sozialwissenschaftliche Schriften zur Forst- und Holzwirtschaft. Band 9. 2009. Frankfurt am Main: Peter Lang Internationaler Verlag der Wissenschaften.
- [7] Mantau, U., 2009. Holzrohstoffbilanz Deutschland, Szenarien des Holzaufkommens und der Holzverwendung bis 2012. Waldstrategie 2020 – Tagungsband zum Symposium des BMELV., vTI Agriculture and Forestry Research Sonderheft 327, pp.27-36.
- [8] Hafner, A., Ott, S. and Winter, S., 2012. Rohstoffverwertung in Nutzungskaskaden. *Holzbau – die neue Quadriga* (3/2012), pp.41-45.

- [9] European Commission 2011/21/ EC of 26 January 2011, on Ressourcenschonendes Europa – eine Leitinitiative innerhalb der Strategie Europa 2020. [online]. Available at: <http://ec.europa.eu/resource-efficient-europe/index_de.htm> [Accessed 19 February 2013].
- [10] GREEN PAPER On Forest Protection and Information in the EU: Preparing forests for climate change SEC(2010)163 final.
- [11] Nordby, A.S., Wigum, K.S. and Berge, B., 2009. Developing the Stavne Timber Block - Life cycle design in practice. Proceeding of CIB W115 Construction Material Stewardship, Lifecycle Design of Buildings, Systems and Materials.
- [12] Bundesministerium für Umwelt, 2012. Ordinance on the Management of waste wood. Berlin: Bundesministerium für Umwelt. [pdf] Available at: <http://www.bmu.de/files/pdfs/allgemein/application/pdf/wastewood_ordinance.pdf> [Accessed 30 November 2012].



7. Service life and moisture safety



100

7.1 Introduction



100

7.2 Some principles of building physics

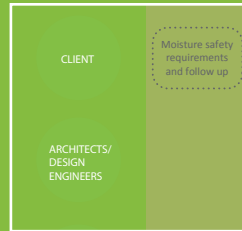

102

7.3 A Method for Including Moisture Safety in the Building Process (ByggaF)

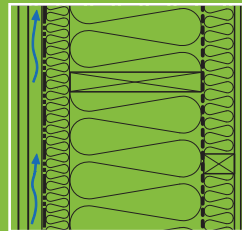

104

7.4 Important factors affecting the moisture safety in wooden buildings



105

7.5 Service life considerations for timber structures



107

7.6 Conclusions

7 SERVICE LIFE AND MOISTURE SAFETY



F.7.1

7.1 Introduction

T. Toratti

The service life of a building is directly related to the use phase duration and therefore it is a significant factor affecting the carbon footprint of the building. The service life has to be sufficiently long in comparison to other building types and it should also be known. The present chapter discusses major factors influencing the service life of timber structures identified by building physics and namely on moisture safety.

To build is an investment for the future. Increasing demands on energy use involves changes to the building envelope (roofing, siding, foundations) and installations. Such measures also change the way the buildings work. Unfortunately, sometimes the result is buildings with moisture, mould and indoor air problems – with a high cost to correct the problems.

When developing a new type of building, a number of factors must be considered simultaneously. This requires expertise in these areas. Not only the building's energy efficiency or CO₂ emissions, but also its moisture control and indoor environment must be assessed and predicted. This section deals with the part

of the holistic approach that has to do with building physics, i.e., heat, moisture and air – and how these are interrelated and influence each other.

7.2 Some principles of building physics

J. Arfvidsson

To get an understanding of the building physical function of a building, we start with a simple example: an old leaky house with poor insulation and space heating (Figure F.7.2).

To the left we see a functioning older building. As long as there is fire in the fireplace the house will be warm and dry, not only in the living space, but also in the crawl space and in the attic. Due to the “chimney effect”, the building is also ventilated. To the right, we see an additional insulated building with the heating system replaced by district heating. The climate in the crawl space, attic, and parts of the outer wall becomes colder and wetter with an increased risk of moisture and mould damage. Because of the now cold chimney, the ventilation performance is also altered.

Air normally contains water vapour. The maximum amount of water vapour the air can contain depends on the temperature. The

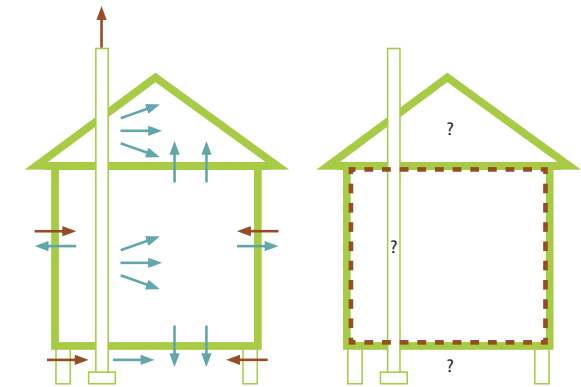

F.7.2

F.7.1 Tent protecting the house from rain during the on-site construction phase before the roof was mounted (photo LTH)

F.7.2 To the left we have a functioning older building, to the right a building with extra thermal insulation

higher the temperature, the more water vapour the air can hold. The relationship between the amount of water vapour present in the air at a certain time (v) and the maximum amount of water vapour (v_s) at the same temperature is called the relative humidity (RH), and this is normally given in per cent units ($RH [\%] = v/v_s$). This relationship is such that if warm air with a certain relative humidity is cooled, the relative humidity will increase. Together with relative humidity, temperature and duration are the main factors affecting the risk of mould growth. A number of models with different assumptions and critical levels have been developed.

Now back to our house. When there is a fire in the fireplace, the chimney is warm. Hot air rises and the chimney creates an under pressure in the living space. The under pressure allows the outdoor air to be sucked into the house through vents, cracks and leaks, i.e., the building is ventilated. The outdoor air that enters is heated and becomes drier. The result is a building that is warm, dry and ventilated. The attic and crawl space are warmed up, partly by heat transferred from the interior and partly by the heat emitted from the fireplace and chimney. The building thus functions fine as long as it is heated. It is warm and dry, with a healthy indoor air, and a warm and dry crawl space and attic.

Do not repeat old mistakes

Why don't we build this way anymore? The answer of course is that the energy consumption becomes too high. Increasing demands on energy use compels us to build with much thicker thermal insulation layers than before. Energy use decreases and less heat is transferred through the building envelope. However, crawlspaces, attics and the outer part of the outer walls become colder and sometimes more moist than before. This increases the risk for moisture and mould damage. We will now take a closer look at various building parts of the energy-saving measures, the possible risks and the important aspects to consider.

Attics

Cold attics may illustrate the problem in this part of the building. A common measure to reduce energy use is to increase the thermal insulation in the attic floor. This means that during the

winter months, the attic gets colder than before. In the living area, the air is usually warmer and more humid than in the attic. What happens if this warm moist air would leak, through cracks and leaks in the attic floor, into the attic? Since hot air can carry more water vapour than cold air, the relative humidity in the attic will increase. Air that contacts cold surfaces, such as the underside of the roof, can result in condensation and eventually cause moisture and mould damages.

Providing airtightness of the attic floor, for example by using a plastic film, can prevent this scenario. Of course it is important to get the attic floor as tight as possible and also of importance is that the airtight layer is placed on the warm side of the insulation. If the airtight layer is placed too far out in the insulation against the cold side, there is a risk that water vapour condenses on the airtight layer, eventually leading to problems.

Even if the airtightness in the attic floor is satisfactory, damages can occur in well-insulated structures. On clear cold nights, the radiation exchange between the roof and the cold sky decreases the temperature of the roof surface, with higher relative humidity and possible condensation as a result. Also the temperature of the inside of the outer roof drops. Cold attics are normally ventilated with outdoor air, and if the inside of the outer roof gets cold enough, the result is high relative humidity or water vapour from the outside air condensing on the inside of the roof. If one is not aware of how this phenomenon occurs, it may be easy to believe that the ventilation in the attic should be increased, which in this case would make the situation worse.

External walls

In a properly designed external wall, the different layers have different functions. At the outer side there is a rain cover in the form of some type of cladding, often wood, brick, metal or plastic material. Inside the cladding there should be a ventilated air space. Possible water leaks that enter through the façade layer should not be able to get further into the wall, but instead be allowed to dry out, either by ventilation or drainage. Next to the air gap is a layer that prevents air movement into the insulation. This type of façade, with separate layers for rain and wind protection is called



F.7.3



F.7.4

F.7.3 Airtightness of the attic (photo SP Trä)

F.7.4 Preparing air tightening between connections in a CLT wood frame wall (photo LTH)



F7.5 Mould-resistant insulation board protecting the studs and a two-step tightened façade with a well-ventilated drainage layer behind the cladding.

a two-step tightened façade. Next to the wind protection layer, there is thermal insulation, and next on the warm side, there are layers to ensure airtightness and vapour tightness. Warm moist indoor air should not be able to get out through the wall to the colder parts and cause moisture and mould damage. This type of exterior wall usually works well.

More recently, external walls have been built with plaster directly on the insulation, without having a ventilated air space.

These are called one-step tightened façades, as rain and wind protection is to be achieved in a single layer. This type of external wall has proven to be very risky in terms of moisture safety. The design is based on the assumption that no water gets into the wall from the outside. Experience shows that this is not always achieved. When this type of walls are exposed to driving rain, water can get into the wall through leaks and cracks, especially in the connections between the windows to the exterior walls, the balconies and the fixings, such as is needed for solar shading and exterior lighting. When moisture gets into the wall, it takes a very long time before drying out again, if at all. Extensive moisture damage may occur and reparatory measures are costly in such cases.

Foundation

An un-insulated foundation can account for a substantial proportion of a building's heat loss. A slab with an underlying thermal insulation is a good design for moisture safety. The underlying insulation makes the concrete warm and dry. This principle of having the thermal insulation on the outside at the cold side is preferred.

When increasing the thermal insulation to the ground floor of a building with a crawl space ventilated with outdoor air, the temperature in the space under the floor will be lower than before. During the winter it gets cold in the crawl space. During spring and summer it will be warmer and outdoor air can contain more water vapour. But the crawl space is still relatively cold. When warm, humid outdoor air enters the crawl space through the vents, it cools down. This increases the relative humidity of the air. If air gets in contact with sufficiently cold surfaces, condensation will

occur. Also moisture coming from the soil will moisten the air in the crawlspace. This increases the moisture risk.

A crawl space foundation that is ventilated with outdoor air is a risk structure in many climates. This would not be so if the foundation was completely open; in this case the foundation climate would simply follow the external climate.

7.3 A Method for Including Moisture Safety in the Building Process (ByggaF)

J. Arfvidsson

Recent studies show that many buildings suffer from moisture-related problems due to negligence during the planning, construction and use phases. These problems could have been avoided if moisture issues had been focused on and dealt with from the initial planning and throughout the building phase. A method for including moisture safety in the building process has therefore been developed [1]. The purpose of the method is to help all stakeholders in the work with moisture safety actions and to document them in a structured way. The aim is to handle and communicate moisture safety measures in the building process with all actors in the building process. The intention is to bring up the moisture issues early in the project and to document the activities and measures to follow up to guarantee a moisture-safe building.

The method includes a number of routines, templates and checklists for clients to formulate requirements for moisture safety and to follow up and document the measures employed by the different participants. There are also tools developed for architects and design engineers, such as check lists and design examples to use for dry building design. For contractors, a number of routines have been developed for moisture control during the construction phase. The method has been applied to a number of building projects. Based on gained experience from these projects, the method and the tools have been evaluated and further revised.

The outline of the method is presented in Figure F.7.6, with the different stages in the building process on the horizontal axis and

the different actors involved on the vertical axis. As a first stage, the work starts at an early stage of planning, when the client decides on the location, type of building, etc. The first step in the method includes the client's decision on the requirements concerning maximum permitted moisture levels, measurements, control methods and frequency, knowledge and training of workers, documentation, etc. The moisture safety requirements should be stated in the building plan, which forms a part of the supporting documentation for the invitations to tender and hence becomes part of the contract documents once the architects, engineers, contractors, etc., are contracted.

The second stage is the design stage, when the consultants design the building to meet the moisture safety requirements, generally and in detail, in the building envelope and bathrooms. The architects and design engineers apply a 'dry building design' and produce documentation of the related work.

In the third stage, construction, the contractor appoints a person responsible for moisture inspection at the building site. He or she identifies the critical parts of the structure and draws up a plan for moisture control, including handling and storage of materials, use of weather protection, on-site moisture inspections and moisture measurements. The contractor makes regular inspection rounds (once a week or more, depending on the building site activity) to check that the plan is being followed. At the end of the construction stage, the moisture safety documentation is put together and presented to the project manager and building operator. In the fourth stage, the use and operation of the building, there are several regimes to be adopted, such as routines for moisture inspection, handling of complaints dealing with leaks, moisture damage and indoor air. The method refers to a number of routines, templates and checklists helping the participants to design and construct moisture-safe buildings. All documents and checklists can be downloaded from the web site www.fuktcentrum.se.

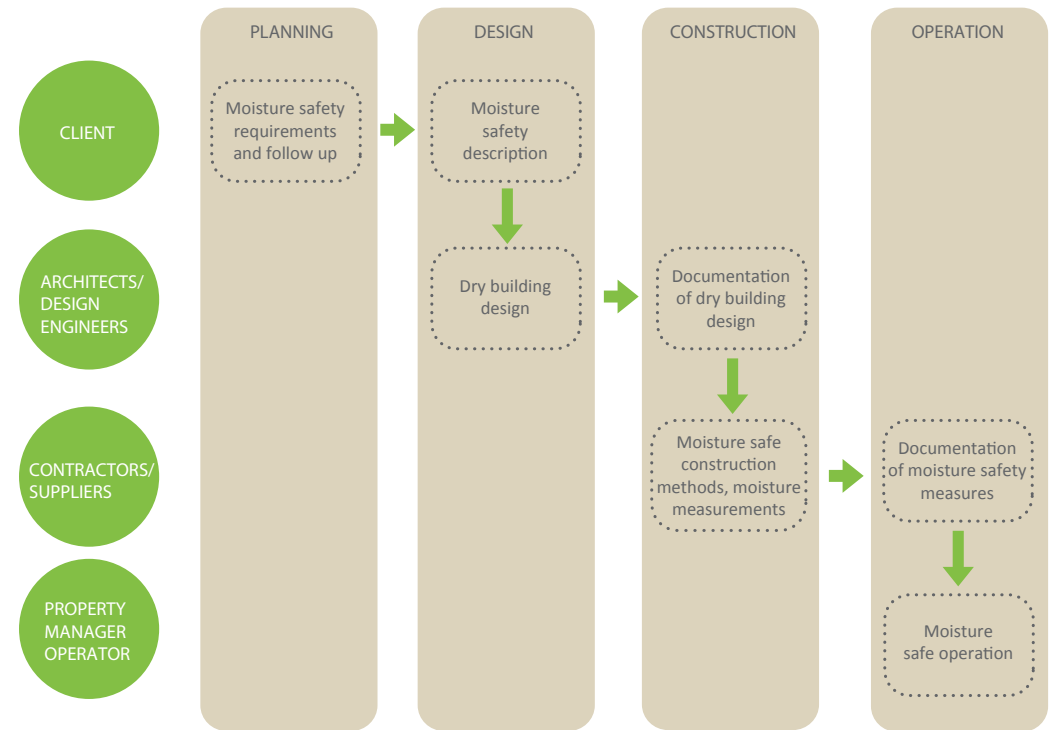

F.7.6 Conceptual outline of the ByggaF method (based on the illustration of Eric Werner)

7.4 Important factors affecting the moisture safety in wooden buildings

S.O. Mundt-Petersen

Besides the knowledge summarized above, a number of specific factors affecting the moisture safety of wooden buildings have been identified in recent research [2]. These factors are especially important in the case of highly insulated building envelopes. In order to build moisture-safe wood buildings with an appropriate service life, at least the following five factors have to be considered.

■ 1. Well-ventilated air gap behind the façade

It is important that walls have an air gap behind the façade that provides a capillary barrier, good drainage and ventilation with a sufficient air-exchange rate. This may be reached if the battens in the air gap between the wind barrier and the cladding are vertical. In case of a vertically installed cladding, the battens need to be well-perforated, or two layers of battens are needed: a horizontal layer and a vertical layer. The air gap needs to be 25-50 mm thick, depending on façade material, and open at the bottom and the top in order to ensure sufficient air ventilation. In case of a brick façade, several ventilation openings (20% of the area) are needed in the bottom bricklayer. The top air gap opening should be designed so that the ventilated air does not flow directly into the ventilation openings of the attic or roof.

■ 2. Protection for mould growth in the external wall

Materials that are located in the outer sections of the wall are occasionally exposed to conditions that might cause mould growth. Usually it is a lower temperature (above 0°C) together with high air vapour content that creates the critical conditions for mould growth. In such cases, adding a mould-resistant insulation board (such as mineral wool or rock wool) on the outside of the insulation layer next to the air gap improves the situation. This protects wooden materials from high humidity and conditions favourable for mould growth. The thickness need of the board is dependent on the total thermal resistance of the wall.

■ 3. Influence of driving rain and site location

A dominating moisture safety factor can be the quantity of driving rain that loads the façade. This depends on the climate condition, which is simultaneous wind and rain. Open areas and seacoasts may have high driving rain loads from the dominating wind directions that may cause moisture problems and mould growth conditions in the structures. A well-ventilated air gap is necessary, which is additionally provided with a good drainage possibility.

■ 4. Drying out possibilities of water from leakages and initial moisture from the building phase

Moisture in the walls should always have the possibility to dry out. The moisture could penetrate the structures through leakages or by precipitation during the building phase. An important factor to facilitate the dry out process is to use a 'low diffusion resistance material in the outer part of the structure, on the inside of the air gap layer. Wood-framed structures must also be protected from precipitation during the building phase.

■ 5. Interior vapour barrier of the wall

The need for an interior vapour barrier varies depending on the climate conditions and the structural design of the wall, mainly on the moisture properties of the layers. In general, a vapour barrier close to the interior surface should be used as the default case in Northern European climate. In order to protect the vapour barrier from damages, it is possible to create an installation layer that could be located at a depth of maximum 20 to 25 percent of the total insulation thickness of the wall. Depending on the wall design, it might be possible to remove the vapour barrier. However, this has to be verified by calculations. Air leakages are to be avoided.

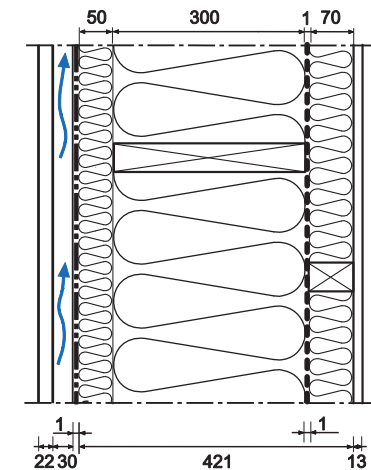

F.7.7

F.7.7 An example of a wood-framed external wall with a 30 mm well-ventilated air gap behind the cladding, 50 mm mould resistant insulation board protecting the organic studs and 70 mm insulated installation layer protecting the vapour barrier from installation works (based on the illustration of Lilian Johansson).

F.7.8 Östra Kvarnskogen in Sollentuna, Sweden

F.7.9 Factors for service life prediction of wooden claddings based on a factor model (only reference values given here).



7.5 Service life considerations for timber structures

T. Toratti

Introduction

The service life of structures is an important part of the life cycle planning of buildings. This determines the length of the use phase of the building or a building part, and thus it has an essential effect also on the carbon footprint of the building.

Material performance based ageing models to estimate the service life of building materials and structures are very scarce. It is a difficult task to model ageing even for constant loading conditions. The loads affecting may be mechanical, climatic, radiation, contaminations, etc., and usually there is also a coupling effect between the loads. Additionally the loads, which are not always well-known, are highly variable in occurrence, duration and magnitude. Characterizing the material performance in an ageing process and combining different loads is a difficult task. There is high variability in the response from tests, and material models are lacking. Actually the best method to estimate the service life of timber structures is based on existing experience.

To predict numeral values, the factor method is a simple empirical method to make use of earlier experience on service life. The ISO standards (ISO 15686 parts 1-11) describe a factor type method to estimate the service life. This is based on a reference state with a known reference life, which is then altered by defining other states by introducing multiplication factors. The values of these factors are usually estimated from experience or simply given by engineering judgments.

Description of a model to estimate service life

The service life of a building depends on a number of factors to be taken into account simultaneously. Considering wood products, exposure conditions and the related durability performance is vital. ISO 15686 describes a factor method that identifies a wide range of parameters that are important for predicting the service life. These are grouped as follows:

Code	Factor	Parameters / factors for estimated service life
A1	Wood material	<ul style="list-style-type: none"> • Wood species: (Natural durability class EN350-2); class 4 =1.0 • Dimension(thickness): between 20-30 mm = 1.0 • Treatment, no treatment = 1.0 • Treatment, no treatment = 1.0 • Modification, no modification =1.0
A2	Coating	<ul style="list-style-type: none"> • Coating type: Transparent wood coating =1.0 • Application properties: Fulfilling recommendations = 1.0 • Surface roughness: Rough sawn = 1.0
B	Structure design and details	<ul style="list-style-type: none"> • Orientation: South = 1.0 • Foundations height from ground to facade: between 300-600 mm = 1.0 • Shelter factor (eave divided by cladding height), between 0.1 – 0.4 = 1.0 • Board layout: Vertical cladding = 1.0 • Ventilation: a ventilation gap exists = 1.0 • Protection of joints and end grains, board ends coated =1.0
C	Work execution	<ul style="list-style-type: none"> • Construction process quality: Normal = 1.0 • Wood moisture content (On site/storage): as required = 1.0 • Fixing of boards: Normal quality level fixing = 1.0
D	Exposure conditions	<ul style="list-style-type: none"> • European macroclimate: Continental European climate zone = 1.0 • European macroclimate, solar radiation: Mid-North Europe = 1.0 • Mesoclimate: partially protected, open distance 50-200 m = 1.0 • Target service life: exceeding 25 years = 1.0
F	Maintenance	<ul style="list-style-type: none"> • Servicing malfunctions: after short delay = 1.0 • Repainting: according to recommendations = 1.0

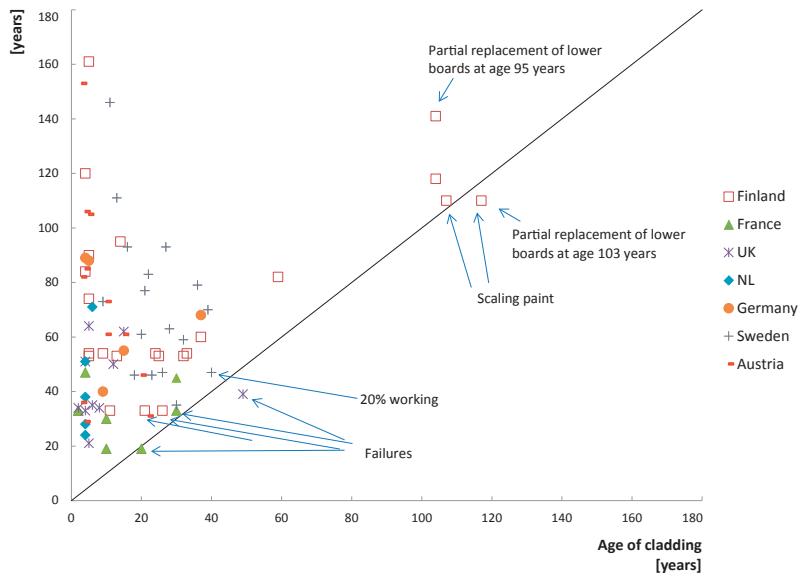

F.7.10 Comparison of the estimated service life of claddings that were surveyed in the Woodexter project in different European countries

- A = Quality of components (e.g., wood natural durability, treatment and coatings);
- B = Design level (e.g., protection by design, good detailing);
- C = Work execution (e.g., quality of workmanship);
- And = Indoor environment (e.g., temperature, RH, condensation);
- E = Outdoor Environment (e.g., climate, driving rain, solar radiation);
- F = In-use conditions (e.g., wear, mechanical impacts);
- G = Maintenance level (e.g., inspections, repair, repainting).

The factor method has been applied for façade and decking. In the following, only the case of façades is shown. Considering façades, all factors above are important except F (in-use conditions), as this load will not affect the exterior side. This could have an effect in very extreme conditions and when there is no air ventilation gap present. However, this situation would be very theoretical. The following is based on works published by Viitanen et al. [3, 4, 5].

A reference case is chosen from which most experience is available. As such, a traditional timber house in Nordic countries with coated spruce boards has been used for some time in Nordic conditions without any significant durability problems when best practices are followed [6].

In Table F.7.9, a list of factors for the service life of wooden claddings is presented. The list provides only the reference factors (resulting in a numeral value of 1.0). Other choices are also possible, but these factors are not given here. These have been determined based on experience and from the engineering judgement of experts.

The climate factor was determined in the Woodexter project, in which Europe was divided into several regions depending

on how prone the climate is on the durability of wood. This was estimated based on the results of a decay model. The model may be found in reference [3].

Comparison of modelled results to a survey of claddings

In the following, a recent survey on timber claddings carried out in the Woodexter project during 2008-2011 [7] is utilized for a comparison to the service life model. In this survey, 80 different claddings from various European countries were analysed for their durability condition. A number of detailed information on materials, coatings, details, geometries and local environment were recorded. This is in principle a good basis for comparison with the factor method.

In Figure F.7.10, the line which is 45 degrees inclined, shows the expected service lives of the claddings by the factor method. All the cladding cases are above this line, except for some cases where failures have actually been observed. This provides some reassurance for the factor method in this application. Some claddings have an age of over 100 years in Nordic climates. This is also predicted by the factor method, which gives high service life estimates for the colder regions. The estimated mean service life of all claddings is 63 years, and the mean age of the claddings during the survey was 29 years. For a more thorough comparison, the factor method should be applied at a later stage where more failed cases would be present. In any case, the results of the model are in line with the survey results and with the failures that have been observed.

Conclusions

It has been shown that for claddings, a 50-year service life is achievable with the correct materials and coatings and with a proper design and detailing. Even longer service lives may be achieved. Nordic continental climates seem to be more advantageous in this respect. This of course requires maintenance of the surfaces as indicated by the recommendations given by the coating/paint producer or

material producer. In the standard EN 1990 Eurocode – Basis of structural design, the indicative design service lives for buildings and other common structures is given as 50 years. For monuments, bridges and other civil engineering structures, this is given as 100 years.

Inner surfaces commonly require servicing at approximately 15 to 20 years, this is normally not a safety or health issue, not related to durability, but merely related to the visual appearance criteria of surfaces.

As for the external wall as a whole, for the parts in between the inner wall and façade, it is expected that this will perform satisfactorily for an indefinite time if no mould growth conditions exist; or if such conditions exist, it is only for a short time period and mould growth does not accumulate during the years. These conditions may be calculated with the building physical analysis of the building and applying a mould growth model as described in the previous sections of this chapter.

7.6 Conclusions

T. Toratti

The present chapter aims to clarify the conditions for a long service life of timber buildings. The service life of a building is directly related to the duration of the use phase, and therefore it is a significant factor affecting the carbon footprint of the building. The service life has to be sufficiently long in comparison to other building types and it should also be sufficiently well known. The present chapter discusses the major factors influencing the service life of timber structures identified based on the building physics and especially the moisture safety.

When developing a new type of building, a number of factors must be considered simultaneously. This requires expertise in several areas. Not only the building's energy efficiency or CO₂ emissions, but also its moisture control and indoor environment, must be assessed and predicted. This section deals with the part of the holistic approach that has to do with building physics, i.e.

with the heat, moisture and air, and how they are interrelated and influence the service life of the building.

Recent studies show that many buildings suffer from moisture-related problems due to negligence during the planning, construction and use phases. These problems could have been avoided if moisture issues had been focused on and dealt with during the initial planning phases and throughout the building phase. Methods for including moisture safety in the building process have been developed in several countries.

A number of specific factors affecting the moisture safety of wooden buildings have been identified in recent studies. These factors are especially important in the case of highly insulated building envelopes. In order to build moisture-safe wooden buildings with an appropriate service life, at minimum the following five factors have to be considered.

■ 1. Well-ventilated air gap behind the façade

It is important that walls have an air gap behind the façade that provides a capillary barrier, good drainage and ventilation with a sufficient air exchange rate.

■ 2. Protection for mould growth in the external wall.

Materials that are located in the outer sections of the wall are occasionally exposed to conditions that might cause mould growth.

■ 3. Influence of driving rain and site location

A dominating moisture load can be the quantity of driving rain that loads the façade. This depends on the climate condition, which might be simultaneously windy and rainy.

■ 4. Dry out possibilities of water from leakages and initial moisture from the building phase

Moisture in the walls should always have a possibility to dry out. The moisture could penetrate the structures through leakages or by precipitation during the building phase.

■ 5. Interior vapour barrier of the wall

The need for an interior vapour barrier varies depending on the climate conditions and the structural design of the wall, but mainly on the moisture properties of the layers.

The service life of structures is an important part of the life-cycle planning of buildings. It has been shown that for claddings, a 50-year service life can be achieved when the correct materials and coatings as well as a proper design and detailing and maintenance scheme are used. However, even longer service lives may be achieved



REFERENCES

- [1] Mjörnell, K., Arfvidsson, J. and Sikander, E., 2012: A method for including moisture safety in the building process. *Indoor and Built Environment* 21(4), pp. 583–594.
- [2] Hägerstedt, S. and Olof., 2012. *Moisture safe wood constructions – guidelines for wall design*. Report TVBH-3052, Building Physics. Lund: Lund University.
- [3] Viitanen, H., Toratti, T., Makkonen, L., Peuhkuri, R., Ojanen, T., Ruokolainen, L. and Räisänen, J., 2010. Towards modelling of decay risk of wooden materials. *European Journal of Wood and Wood Products*, 68 (3), pp. 303 – 313.
- [4] Viitanen, H., Toratti, T., Makkonen, L., Pehkuri, R., Ojanen, T., Thelandersson, S., Isaksson, T. and Frühwald Hansson, E., 2011. *Climate data - exposure conditions in Europe* [pdf]. Available at: <<http://www.vtt.fi/inf/pdf/workingpapers/2011/W181.pdf>>. VTT, Espoo. 45 p. VTT Working Papers : 181. (2011a).
- [5] Viitanen, H., Toratti, T., Makkonen, L., Thelandersson, S., Isaksson, T., Frühwald, E., Jermer, J., Englund, F. and Suttie., E., 2011. *Modelling of service life and durability of wooden structures*. 9th Nordic Symposium on Building Physics - NSB 2011.
- [6] Viitanen, H., Vinha, J., Salminen, K., Ojanen, T., Peuhkuri, R., Paajanen, L. and Lähdesmäki, K., 2008. *Moisture and biodeterioration risk of building materials and structures*. BEST 1 Conference, Minneapolis, USA, June 10–12, 2008.
- [7] Woodexter project, WP2 unpublished output: DVD “Inventory of Cladding”, which contains the completed proformas, summary reports and additional photographs from six countries – Austria (Holzforschung Austria), Finland (VTT) , France (FCBA), Germany (University of Göttingen), Sweden (SP) and the United Kingdom (BRE), BRE, Garston. (2011).

- F.7.11 Luukku plus energy house, facade detail
F.7.12 CLT based passive house in Sistrans, Austria





112

8.1 Introduction



114

8.2 Wälludden as a case study for three new wood building systems, Sweden

8. Case studies



124

8.3 4 Holz, Mietraching, Germany



128

8.4 Austrian buildings



138

8.5 Joensuun Elli, Finland



142

8.6 Tervakukka passive house, Finland



146

8.7 Progetto C.A.S.E., L'Aquila, Italy



150

8.8 Lessons learned

8 CASE STUDIES

8.1 Introduction

M. Kuittinen

This chapter introduces eight buildings from Austria, Finland, Germany, Italy and Sweden. They represent different types of residential buildings but share a common frame material – wood.

The Wälludden study from Sweden compares the carbon efficiency of the same building designed in five different construction systems (timber frame, post and beam, cross-laminated timber wall panels, volume elements and concrete sandwich panels). Furthermore, the study includes simulations in standard and passive house energy efficiency levels. An interesting comparison is made by applying both attributional and consequential LCA approaches and illustrating their differences.

Studies from Mietraching (Germany) and Joensuu Elli (Finland) show the carbon efficiency of massive wooden residential buildings and their construction work. Careful documentation

of pre-fabrication reveals new findings about on-site and off-site construction methods. The results also underline that case-specific differences can be significant, especially if long transport distances are involved.

Italian L'Aquila gives an example of massive CLT-framed timber buildings that have been erected very quickly after the earthquake in 2009. This study shows the important but often neglected role of foundations in the dominance of the carbon footprint of buildings.

The Austrian case study buildings include a multi-storey house and a row house in Vienna and a single-family house in Schönkirchen. All three are good examples of a high degree of prefabrication. The important aspect of carbon storage in wooden roof and wall elements and the emissions caused by a foundation can be well-observed in these studies.

Finnish Tervakukka from the Tampere Housing Fair 2012 shows a realistic case of implementing a carbon footprint calculation in the typical design process of a single-family passive house.

It highlights the importance of small design choices, such as claddings, floorings and insulation material.

Common parameters for all case studies are:

- All studies include the production phase (A1-3), most include the construction phase (A4-5) and end-of-life (C) as well.
- The study period for the use phase has been set to 50 and 100 years.
- The Ecoinvent database has been used if case specific-data has not been available.

Coverage of each case study in terms of life cycle stages and building parts can be found in Table F.8.8-1.



F.8.1-1 Eight buildings within five European countries have been studied.

8.2 Wälludden as a case study for three new wood building systems

Location	Växjö, Sweden
Client	Södra Timber AB
Architect	Mattson & Wik Arkitektkontor
Construction company	Trähus Sydöst AB



F.8.2-1

A. Dodoo, L.Gustavsson, D.Peñaloza, R.Sathre

The Wälludden building (Figure 8.2-1) is a four-storey light-frame wood-frame building constructed in the 1990s in Växjö, Sweden. The building contains 16 apartments and has a total heated floor area of 1190 m². The foundation consists of a reinforced concrete slab laid on expanded polystyrene and crushed stones. Two-thirds of the outer façade is plastered with stucco, with the remainder covered with wood panelling. The roof consists of layers of asphalt-impregnated felt, wood panels, mineral wool between wooden roof trusses, polythene foils and plasterboards.

The Wälludden building is used as a case study to model three wood building systems: a cross-laminated timber (CLT) system; a beam and column system; and a volumetric modules system.

Assessment

The CLT system building has floors, walls and structural systems constructed with prefabricated massive wood using CLT. For the beam and column system building, laminated veneer lumber (LVL)

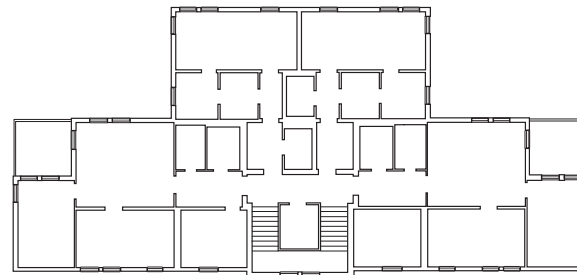

F.8.2-2

and glulam columns and beams are the main structural components. The modular system building is constructed using individual volumetric elements built in an off-site factory and transported to the building site. The characteristics of the conventional and the passive house versions of the three building systems are given in Table 8.2-4. The passive house versions have better airtightness and a lower overall building envelope U-value and include efficient water taps. The number of floors, apartment area, common area and room height of the passive house buildings are the same as in the conventional building systems. The configuration of the modular system results in a slightly greater floor area compared to the two other systems. Otherwise the building systems have the same architectural details

Structures and construction methods

Foundation and floors

For all the cases, the foundations and the basement ground slab are made of reinforced structural concrete. A 300mm layer of expanded polystyrene is included for insulation.

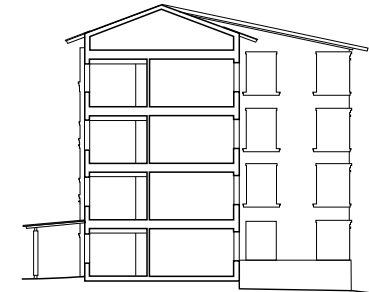

F.8.2-3

- F.8.2-1 Facade of the building
- F.8.2-2 Upper floor plan, 1:200
- F.8.2-3 Section, 1:200

External walls

Every design includes a ventilated plaster façade system. For the modular system timber stud walls bear the load, while two layers of glasswool are used as insulation, adding extra glasswool and a layer of rockwool for the passive house design. The interior sides of the walls are covered with gypsum board.

The walls in the CLT system are also load-bearing, using CLT elements. The insulation is provided by two layers of rockwool, adding another layer and extra material to the other layers to comply with the passive house standard. The interior side is covered by gypsum board.

As for the column and beam system, in-fill external walls are used, while a glulam beam and column system supports the load. The internal side of the walls is covered by gypsum board, while rockwool is used for insulation. Extra insulation material is added in order to comply with the passive house standard.

Roof

All the designs include a two-layer asphalt sheeting cover on the roof, followed either by tongue-and-groove panels or LVL board. Only the modular system and the CLT system feature roof trusses, while the ceiling side of the roof is covered by gypsum board in all the designs. Loose rockwool is used for insulation in the CLT system and glass wool is used in the other two; adding extra insulation material to the same layers for the passive house designs.

Intermediate floor

All the designs feature a flooring system using laminated wood and expanded polyethylene and gypsum board covering for the ceiling side. The modular system includes particle board, glulam beams and plywood, while the CLT elements system includes CLT and glulam and the column-beam system LVL beams. Both the modular and column and beam systems are insulated with glasswool, while the CLT system uses rockwool. All systems are the same for conventional and passive house designs.

Description	CLT system		Beam and column system		Modular system	
Number of floors	4		4		4	
Apartment area (m ²)	935		928		928	
Common area	130		130		130	
Room height	2.55		2.55		2.55	
U-values (W/m ² K):	<i>Conventional</i>	<i>Passive</i>	<i>Conventional</i>	<i>Passive</i>	<i>Conventional</i>	<i>Passive</i>
Roof	0.087	0.080	0.086	0.080	0.084	0.080
External wall	0.154	0.104	0.152	0.110	0.154	0.111
Separating wall	0.160	0.160	0.224	0.215	0.196	0.196
Internal floors	0.127	0.127	0.130	0.130	0.135	0.135
Windows	1.200	0.800	1.200	0.800	1.200	0.800
Doors	1.200	0.800	1.200	0.800	1.200	0.800
Ground Floor	0.124	0.124	0.124	0.124	0.124	0.124
Infiltration (l/s m ² @ 50 Pa)	0.40	0.20	0.55	0.40	0.55	0.40
Mechanical ventilation	Exhaust	Balanced	Exhaust	Balanced	Exhaust	Balanced
Heat recovery (%)	-	80	-	80	-	80
Water taps	standard	efficient	standard	efficient	standard	efficient

Standard

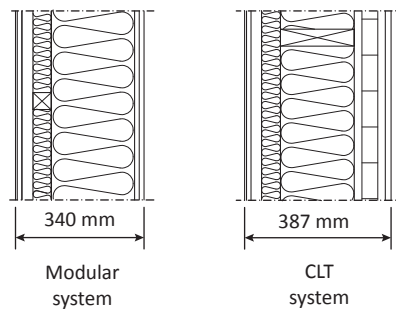

F.8.2-5

Passive house

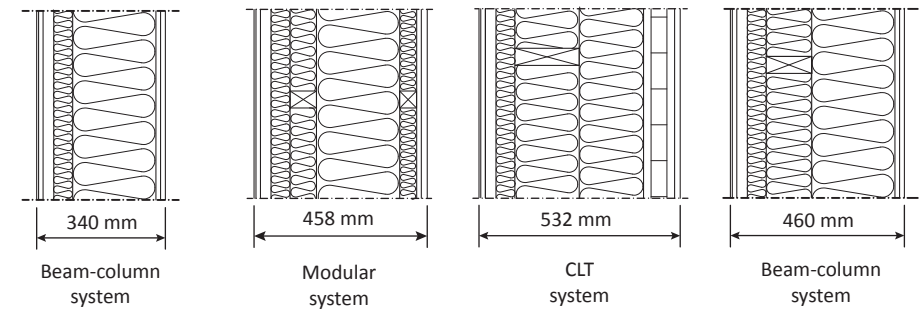

F.8.2-6

F.8.2-4 Characteristics of building systems for the conventional and passive house standards.

F.8.2-5 Exterior walls details for conventional house

F.8.2-6 Exterior walls details for passive house

Additional structural features

All the designs include a CLT wooden balcony. Moreover, the staircase-elevator structure in the column-beam system is made of concrete.

Life cycle assessment

In this study a consequential or attributional LCA approach has been used to assess the life cycle primary energy and GHG balances of building systems.

8.2.1 Consequential approach

Wood product substitution raises two important questions: what would happen without the substitution, and how will the substitution system perform. In principle, marginal changes will occur in both the reference system (the non-wood product system) and the substitution system (the wood product system). These changes need to be analyzed comprehensively with a consequential LCA approach. All effects that may be associated with changes in output are considered in consequential LCA. We analyze and compare the primary energy and greenhouse gas (GHG) emissions over the life cycle of the three wood-frame building systems (Figures 8.2-5, 6, 7). Our analysis includes the entire energy and material chains from the extraction of natural resources to the end-use and encompasses the production, operation and end-of-life phases of the buildings. The harvested biomass is assumed to come from Swedish production forests that are managed with an increasing carbon stock on the landscape level.

Production phase

Primary energy

The production phase's primary energy is calculated as the primary energy used for material production and building construction. The net energy (lower heating values) of biomass by-products that can be recovered and made available for external use during the material life cycle is calculated and shown separately. Our calculation of the primary energy for material production, building

construction and the net energy of by-products are based on the method of Gustavsson et al. (2010).

GHG emission

The GHG emission is calculated as the CO₂ emission to the atmosphere from fossil fuel used to extract, process and transport the materials, and from industrial process reactions of cement manufacture. The carbon stock in wood building materials and avoided fossil CO₂ emission if biomass residues replace fossil coal are calculated and given separately. The calculation of the GHG emission for material production and building construction, and carbon stock in wood building materials and avoided fossil due to biomass residues are based on the method by Gustavsson et al. (2006). The industrial process reactions of cement manufacture include calcination and carbonation and are calculated with data from Dodoo et al. (2009).

Operation phase

We calculate the operation final energy use for space heating, ventilation, domestic hot water heating and household electricity with the VIP+ dynamic energy balance program (Strusoft, 2010). The space heating demand is modelled for the climate conditions of Växjö, Sweden, assuming indoor temperatures of 22°C for the living areas and 18°C for the common areas of the buildings.

The primary energy needed to provide the final energy for the operation activities, and the associated GHG emissions, are calculated with the ENSYST program (Karlsson, 2003). We calculate the primary energy use and GHG emissions for cases where the buildings are heated with electric resistance heaters or bedrock heat pump with 95% electricity supply from stand-alone plants using biomass steam turbine (BST) technology and the remaining from light-oil gas turbine technology. We also analyzed the buildings heated with district heating from a combined heat and power (CHP) plant and heat-only boilers (HOB). We assume that 80% of the district heat is supplied from the CHP plant using BST technology, and 16% and 4% are supplied by biomass and light-oil HOB, respectively (Gustavsson et al., 2011). We allocate the cogenerated electricity using the subtraction method, assuming that

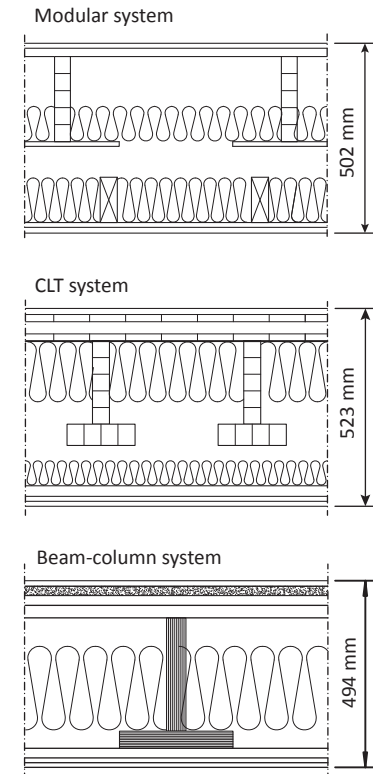

F.8.2-7 Intermediate floor details for conventional and passive houses

the cogenerated power replaces electricity from a stand-alone plant using a similar technology (Gustavsson and Karlsson, 2006).

End-of-life phase

The buildings are assumed to be dismantled after their service life, with the demolished concrete, wood and steel materials recovered. We assume that the concrete is recycled into crushed aggregate, the steel is recycled into feedstock for production of new steel, and wood is used for energy. The end-of-life primary energy use and GHG emissions are calculated considering the energy use to demolish the buildings and to recover and transport the concrete, steel and wood materials contained in the buildings. We follow the Doodoo et al. (2009) method and assume that 90% of each material is recovered.

Complete lifecycle

The primary energy use and GHG emission over the complete life cycle of the buildings are calculated assuming a 50-year life span, considering all life cycle phases.

Data

The mass of materials in the buildings were estimated based on construction drawings and data provided by the building systems companies. The thermal characteristics of the building envelopes were extracted from the drawings and supplementary information from the companies. The specific end-use fossil fuel and electricity data (Table F.8.2-8) for extraction, processing, and transport of materials is primarily from a Swedish study by Björklund and Tillman (1997). For steel, we assumed that the production is based on 50% ore and 50% scrap steel. Feedstock energy value is not included in the energy content of the materials.

The fuel cycle energy input, including extraction, transport, processing, conversion and distribution of the energy carriers are taken to be 10% for coal, and 5% for oil and natural gas, of the delivered fuel (Gustavsson and Sathre, 2006). The fuel-cycle carbon intensity of the fossil fuels is assumed to be 0.11,

0.08 and 0.06 kg C/kWh for coal, oil, and fossil gas, respectively (Gustavsson et al., 2006).

Results

The production phase primary energy use and GHG emission for the building systems are shown in Table 8.2-9, divided into different end-use energy carriers: fossil fuels, biomass and electricity. Significant quantities of biomass residues are available due to the large quantities of wood-based materials in the buildings. The negative numbers represent energy available from recovered biomass residues or avoided emission to the atmosphere due to the replacement of fossil energy. The total production primary energy use is lowest for the CLT building systems, followed by the modular and the beam and column systems. When the buildings are built as a passive house instead of a conventional house, the material production primary energy increases by 10%, 5% and 4%, for the CLT, beam and column and modular building systems, respectively. The passive beam and column building system has 18% and 8% higher material production emission than the CLT and modular alternatives, respectively. The net carbon emission of all the building systems is negative if the carbon temporarily stored in the wood-based materials and avoided emission due to the recovery and use of biomass residues are taken into account assuming conservatively that the carbon stock is not increasing. In reality the Swedish productive forest is managed in such a way that the forest biomass and hence the carbon stock is increasing over time.

The annual operation primary energy use and GHG emission of the buildings with different heating systems are shown in Table F.8.2-10. The primary energy for household electricity is the same for all the buildings and is proportionally more significant if the heat supply is from district heating. The primary energy for space and tap water heating for the conventional house with district heating is lower compared to that of the passive house with electric resistance heating. The electric-based heating systems have higher emissions than the district heating system, due to the high conversion losses in the stand-alone plant. The electrically heated passive houses have greater

Material	Coal	Oil	Fossil gas	Biofuel	Electricity
Concrete	0.09	0.10	-	-	0.02
Plasterboard	-	0.79	-	-	0.16
Lumber	-	0.15	-	0.70	0.14
Particleboard	-	0.39	-	1.40	0.42
Steel (ore)	3.92	0.86	1.34	-	0.91
Steel (scrap)	0.06	0.08	0.44	-	0.57
Insulation	2.00	0.36	0.02	-	0.39

F.8.2-8 Specific final energy (kWh/kg) to extract, process, and transport selected materials.

F.8.2-9 (below)

Primary energy use and GHG emission for the production phase of the building systems

Next page:

F.8.2-10 Annual operation primary energy use and GHG emission for buildings with different end-use heating when energy supply is from BST technology.

F.8.2-11 End-of-life primary energy use and GHG emission and benefits for buildings. Positive numbers denote energy use or emission to the atmosphere. Negative numbers denote energy content (lower heating value) of recovered biomass residues or emission avoided if fossil coal is replaced.

Material	Primary energy use (kWh /living area [m ²])						GHG emission (kg CO ₂ /living area [m ²])					
	CLT system		Beam and column system		Modular system		CLT system		Beam and column system		Modular system	
	Conventional	Passive	Conventional	Passive	Conventional	Passive	Conventional	Passive	Conventional	Passive	Conventional	Passive
Energy or CO₂ emission												
<i>Material production</i>												
Fossil fuels	307	341	404	418	359	370	96	108	127	132	112	116
Electricity	233	252	283	307	295	306	92	100	112	122	117	122
Bioenergy	144	156	136	139	116	122						
Net cement reaction ^a							9	9	13	13	9	9
Total	684	749	823	864	770	798	197	217	252	267	238	247
<i>Building construction</i>												
Fossil fuel	14	15	16	17	16	16	5	5	6	6	6	6
Electricity	14	15	16	17	15	16	5	6	6	7	6	6
Total	28	30	32	34	31	32	10	11	12	13	12	12
Total	712	779	855	898	801	830	207	228	264	280	250	259
Energy or C stock / CO₂ avoided												
Carbon in wood material							-213	-231	-197	-204	-166	-178
<i>Biomass residues</i>												
Forest harvest ^b	-268	-287	-259	-267	-161	-174	-108	-116	-105	-108	-65	-71
Wood processing	-721	-759	-724	-744	-300	-335	-283	-298	-284	-292	-117	-131
Construction site ^b	-66	-72	-60	-63	-51	-55	-26	-29	-24	-25	-21	-22
Total	-1055	-1118	-1043	-1074	-512	-564	-630	-674	-610	-629	-369	-402
Overall balance	-343	-339	-188	-176	289	266	-423	-446	-346	-349	-119	-143

^a Net cement reaction is the calcination emission minus carbonation uptake assuming a 50-year service life.

^b Lower heating value of biomass residues or avoided fossil GHG emission if biomass residues replace fossil coal.

Material	Primary energy use (kWh /m ² [living area])						GHG emission (kg CO ₂ /m ² [living area])					
	CLT system		Beam and column system		Modular system		CLT system		Beam and column system		Modular system	
	Conventional	Passive	Conventional	Passive	Conventional	Passive	Conventional	Passive	Conventional	Passive	Conventional	Passive
Electric resistance heated												
Space heating	186.5	64.3	189	78.4	188.2	77.2	6.6	2.3	6.6	2.7	6.6	2.7
Tap water heating	74.7	44.8	74.7	44.8	74.6	44.8	2.6	1.6	2.6	1.6	2.6	1.6
Ventilation electricity	7.6	15.3	7.6	15.3	7.6	15.3	0.2	0.6	0.2	0.6	0.2	0.6
Household electricity	94.4	94.4	94.4	94.4	94.3	94.3	3.3	3.3	3.3	3.3	3.3	3.3
Facility electricity	39.6	39.6	39.6	39.6	39.5	39.5	1.4	1.4	1.4	1.4	1.4	1.4
Total from Operation	402.8	258.4	405.3	272.5	404.2	271.1	14.1	9.2	14.1	9.6	14.1	9.6
Heat pump heated												
Space heating	64.3	22.1	65.1	27	64.9	26.7	2.5	0.9	2.5	1	2.5	1.0
Tap water heating	25.8	15.5	25.8	15.5	25.7	15.5	1	0.6	1	0.6	1.0	0.6
Ventilation electricity	7.6	15.3	7.6	15.3	7.6	15.3	0.2	0.6	0.2	0.6	0.2	0.6
Household electricity	94.4	94.4	94.4	94.4	94.3	94.3	3.3	3.3	3.3	3.3	3.3	3.3
Facility electricity	39.6	39.6	39.6	39.6	39.5	39.5	1.4	1.4	1.4	1.4	1.4	1.4
Total from Operation	231.7	186.9	232.5	191.8	232.0	191.3	8.4	6.8	8.4	6.9	8.4	6.9
District heated												
Space heating	47.1	16.2	47.7	19.7	47.5	19.5	1.6	0.6	1.6	0.7	1.6	0.7
Tap water heating	18.8	11.3	18.8	11.3	18.8	11.3	0.7	0.3	0.7	0.3	0.7	0.3
Ventilation electricity	7.6	15.3	7.6	15.3	7.6	15.3	0.2	0.6	0.2	0.6	0.2	0.6
Household electricity	94.4	94.4	94.4	94.4	94.3	94.3	3.3	3.3	3.3	3.3	3.3	3.3
Facility electricity	39.6	39.6	39.6	39.6	39.5	39.5	1.4	1.4	1.4	1.4	1.4	1.4
Total from Operation	207.5	176.8	208.1	180.3	207.7	179.9	7.2	6.2	7.2	6.3	7.2	6.3

Material	Primary energy use (kWh / m ² [living area])						GHG emission (kg CO ₂ / m ² [living area])					
	CLT system		Beam and column system		Modular system		CLT system		Beam and column system		Modular system	
	Conventional	Passive	Conventional	Passive	Conventional	Passive	Conventional	Passive	Conventional	Passive	Conventional	Passive
Demolition energy use	11	11	11	11	11	11	3	3	3	3	3	3
<i>End-of-life benefits:</i>												
Concrete recycling	-2	-2	-2	-2	-2	-2	-1	-1	-1	-1	-1	-1
Steel recycling	-16	-16	-40	-40	-11	-11	-6	-6	-14	-14	-3	-3
Wood recovery for bioenergy	-527	-572	-486	-503	-409	-439	-213	-231	-196	-203	-165	-178
Total	-534	-579	-517	-534	-411	-441	-217	-235	-208	-215	-166	-179

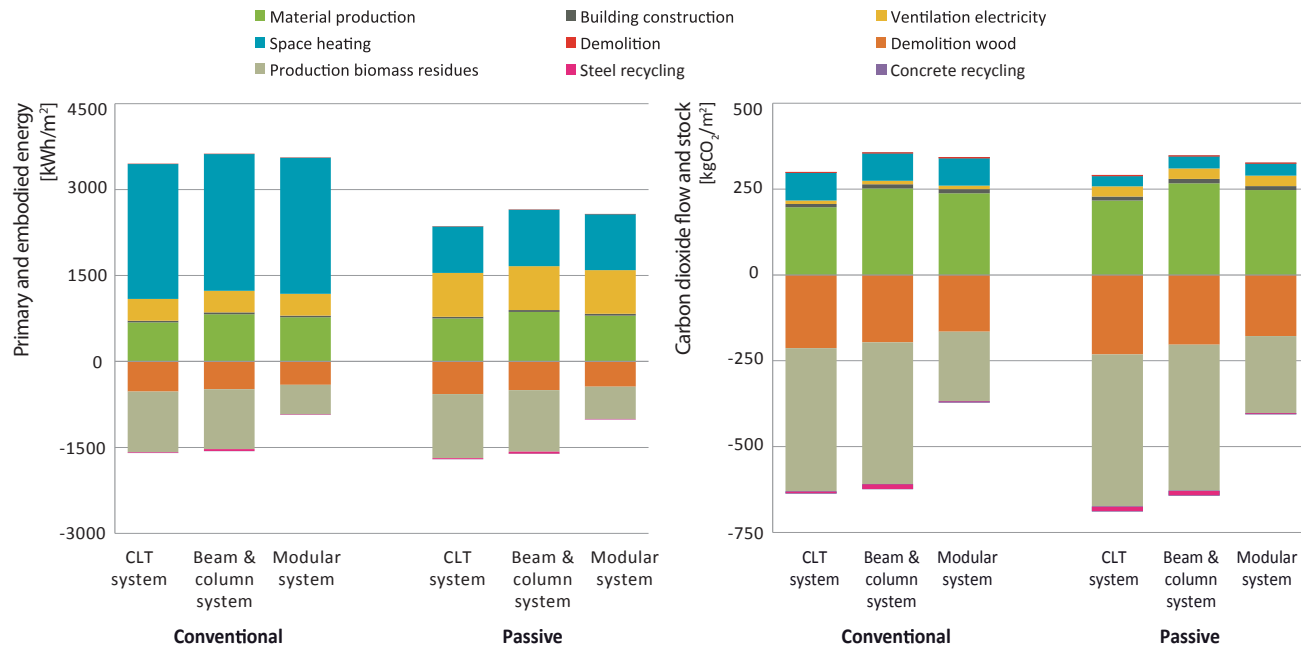

F.8.2-12a (left)
F.8.2-12b (right)

Primary energy use (a) and GHG emission (b) for the life cycle phases of the district heated buildings with assumed life span of 50 years. Energy supply is based on BST technology. Positive numbers denote energy use or GHG emission to the atmosphere. Negative numbers denote the lower heating value of recovered biomass residues or GHG emissions avoided if fossil coal is replaced.

Next page:
From left to right
F.8.2-13
F.8.2-14
F.8.2-15

operation primary energy use and emissions compared to the district heated conventional houses.

Table F.8.2-11 shows the end-of-life phase primary energy and GHG implications of the buildings. The passive houses give a greater end-of-life primary energy benefit than the conventional houses. The energy and GHG benefits of demolished wood are most significant, due to the use of wood-based materials in the buildings. The energy benefit of recycling steel is small. The primary energy benefit through recycling of concrete is minor and similar for all the houses.

The primary energy use for tap water heating and for household and facility electricity constitutes a significant part of the operation energy, but these demands depend to a large extent on the users and not on the construction. Figure 8.2-12a and 8.2-12b show the primary energy and carbon emission for production, space heating and ventilation during 50 years, and end-of-life for the buildings, respectively. The buildings are district-heated and the energy supply

is based on BST technology. The operation phase dominates the lifecycle primary energy use for both the conventional and the passive house versions of the building system. Material production accounts for a large share of the lifecycle GHG emissions for the buildings, as energy supply is based on biomass-based district heating. Overall, the CLT building systems have slightly lower life cycle primary energy use and emissions compared to the beam and column or the modular building systems.

Conclusions

In this study, we have explored the role of wood in carbon efficient construction and analyzed the climate implications of three wood building systems with different level of energy- efficiency. The building systems comprise CLT, beam and column and the modular systems. Our results show the importance of a system-wide life cycle perspective and choice of heating system in reducing primary energy use and GHG emissions in the built environment. Final energy use is significantly lower when the building systems

are constructed as a passive house. Still, the operation primary energy use and GHG emissions for the electrically heated passive houses are greater compared to the district heated conventional alternatives, showing the importance of the heat supply system.

Large amounts of biomass residues are produced due to the use of wood framing material for the building systems. The energy content of the residues is significant relative to the primary energy used for production of the buildings. The primary energy for operation still dominates for a building constructed as a passive house. The passive house versions of the building systems with cogeneration-based district heating give low life cycle primary energy use and GHG emissions. Overall, the CLT system passive house gives the lowest life cycle primary energy and GHG balances, as this system has better airtightness compared to the other building systems studied. Hence improved airtightness is crucial to achieve a low energy building. In summary, wood-frame passive houses with an energy-efficient heat supply reduce climate impacts.

OPERATIONAL ENERGY USE

kWh/year

	Heat	Electricity
Modular system conventional	93,627	2,721
Modular system passive house	43,461	5,442
CLT system conventional	92,372	2,703
CLT system passive house	38,581	5,406
Column-beam conventional	93,225	2,703
Column-beam passive house	43,570	5,406

8.2.2 Attributional approach

The results described here correspond to a cradle-to-grave LCA, including every life cycle stage of the building for all the alternative designs. An attributional approach was followed; while allocation issues were handled using physical allocation only (mass). The main impact category included in the results is global warming potential, so the carbon footprint is used as an indicator. Cumulative energy demand (renewable and non-renewable) is included as well.

The production phase is modelled using a bottom-up approach, as the required materials and their amounts were calculated using the building designs, and all the processes required to produce these materials are included, from raw material extraction to the producer's gate. The construction phase includes the energy required for construction (assumed as electricity) and the materials to the production site. The additional materials required due to losses are included in the production phase.

LIFE CYCLE PRIMARY ENERGY USE

MJ/m² of living area

	Non-Renewable	Renewable
Modular system conventional	1 017	6 881
Modular system passive house	911	4 342
CLT system conventional	1 021	6 931
CLT system passive house	918	4 136
Column-beam conventional	1 083	6 943
Column-beam passive house	980	4 406

The use phase includes the heat and electricity consumption for the whole life cycle and some maintenance activities of the building. The use phase energy was calculated using the VIP+ software energy balance model, while for the maintenance activities, assumptions were made regarding the life span of some materials. A building service life of 50 years was assumed.

The end-use phase scenario is based on the Swedish long-term waste management plan, assuming that 90% of the construction waste will be recycled and the rest would be incinerated or treated. The end-use phase also includes the energy required for the demolition activities. Some use and end-use benefits are shown in the results such as the carbon stored by the wood materials and the energy recovery potential environmental benefits of wood materials after the demolition activities, assuming 90% recovery of the demolition waste.

It is assumed that all the wood products come from sustainably managed forests, so the forest biomass stock is always in balance.

LIFE CYCLE CARBON FOOTPRINT

kg CO₂e

	Per whole building	Per m ² of living area
Modular system conventional	502,384	537
Modular system passive house	377,485	403
CLT system conventional	500,229	539
CLT system passive house	362,372	390
Column-beam conventional	522,746	563
Column-beam passive house	401,223	432
Original concrete frame	525,194	565
Original wood frame	627,462	676

This means that the wood materials are considered to be carbon neutral, so the carbon uptake in the forest and the greenhouse gas emissions from their incineration are not considered.

Data

The data used for the production phase varies for different types of building products. For wood products, windows, doors, glues and glasswool, mainly data from EPDs developed by SP Trä in the past were used. All of them are specific to the site, company or technology; and all were developed around the late 1990's and early 2000's.

For steel products, LCI data from the International Iron and Steel Institute (published in 2001) was used. As for materials such as rockwool, concrete and gypsum board; the data used was obtained from the study LCA of Building Frames (Björklund & Tillman, 1997). Data from plastics and GRP was obtained from Ecoinvent

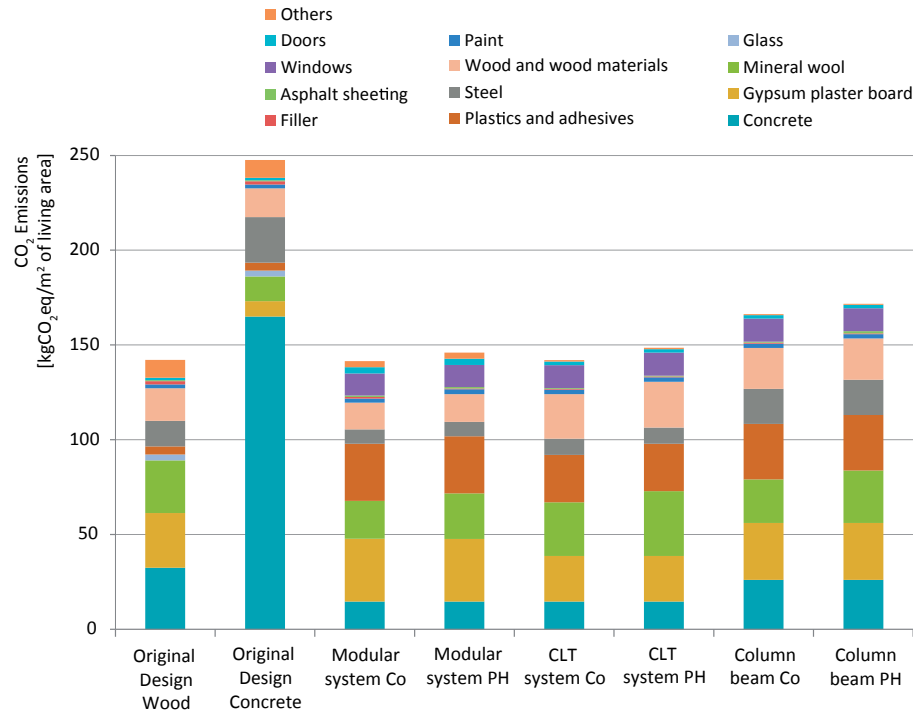

F.8.2-16 CO₂ emissions from the production phase

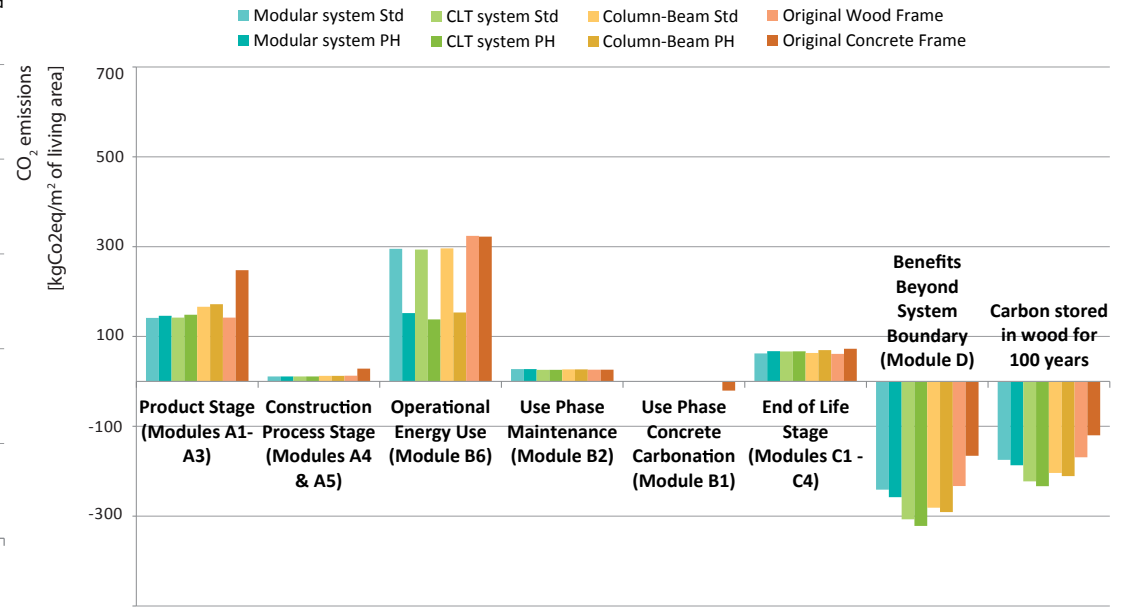

CO₂ emissions for the building's life cycle (50 year service) F.8.2-17

and the ELCD database 2.0. All this data is generic, and consists of industrial averages.

Regarding the use phase heat production, specific data from Växjö energy was used from their 2011 environmental report. The Swedish electricity production mix was modelled using official statistics from the Swedish Energy Agency and EPDs from Vattenfall, the biggest electricity producer in the country. The end-use phase treatment and recycling processes are all modelled using Ecoinvent data, similar to the materials transport to the site in the construction phase. As for the energy for construction and demolition activities, data from Björklund & Tillman was used.

Results

Primary energy demand

There is an obvious trend comparing different energy efficiency standards for each building system, with around 30% savings in primary energy going from conventional buildings to passive

houses. When comparing different building systems there is no notable difference, with the CLT system having slightly less primary energy use than the others.

Carbon footprint

The modular and CLT systems have a lower carbon footprint than the other two systems. The same trend of a 30% lower carbon footprint can be observed from adopting the passive house design.

Other findings

One interesting aspect to point out from these findings is that there seems to be a correlation between carbon footprint and primary energy use, as the differences between designs are proportionally very similar.

It can also be noted that the small difference in living area did not affect much the results for the modular system, which implies that the space distribution for all the designs can be comparable.

Conclusions

The results show that from a life cycle perspective, the benefits of lowering the use phase energy demand by adding additional insulation are significantly higher than the additional environmental impact from producing the additional insulation. This means that for both the carbon footprint and primary energy use, passive house designs are more eco-efficient than conventional designs.

The carbon footprint for all the wood-framed designs is lower than for a concrete-frame design. Even as an old energy efficiency standard was used for the latter, which means that they are not really comparable to the modern designs modelled in this assessment. Nevertheless, they can be compared to the wood frame design for the original building, and still the carbon footprint is around 15% lower. This difference can be estimated to rise to 30% in the case of passive house concrete and wood frame designs.

When measuring the contribution to the carbon footprint and energy use by material group, the mineral-based materials account

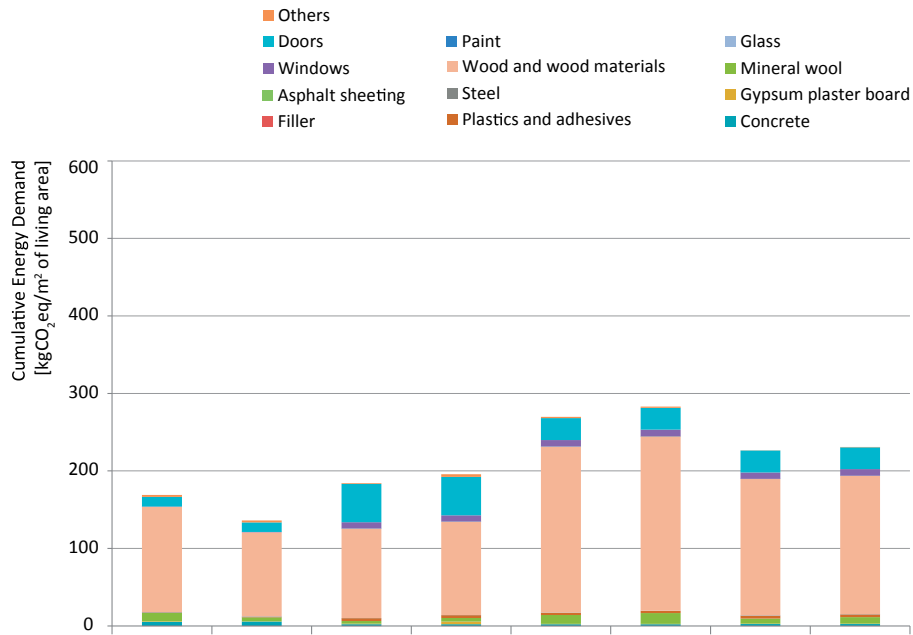

F.8.2-18 Renewable energy demand for the production phase

for a significant share of the environmental impact, even as the proportion in mass is not that different. This is more relevant for the column-beam system, when an additional amount of concrete increased the total environmental impact of the building.

In general, the kind of building system used for building design has a low influence on the associated environmental impact. Furthermore, the choice of energy efficiency category is much more influential; while the type of materials used (bio-based or mineral-based) can influence the result too. The influence of the choice of material increases with higher use phase energy efficiency, as the gap between the use phase and the production phase closes and the production phase becomes more influential.

This means that for future designs with increased use phase energy efficiency, the production and end-of-life stages will be more relevant, and so will be the choice of material.

8.2.3 Final conclusions

The results of the two approaches seem to be similar but differ in magnitude, due to the differences in methodological approaches, e.g., the system boundary definition, the assumed electricity supply, and solving allocation issues. The consequential approach use data on marginal electricity production in northern Europe, which is considered to be coal-based, while the attributional approach used data on the Swedish average national electricity mix, which is based mainly on hydro and nuclear power. In general, both the attributional and consequential approaches show that the CLT system passive house gives the lowest life cycle primary energy and GHG balances, compared to the other building systems. This study illustrates the significance of the approach for a life cycle climate impact analysis of buildings.

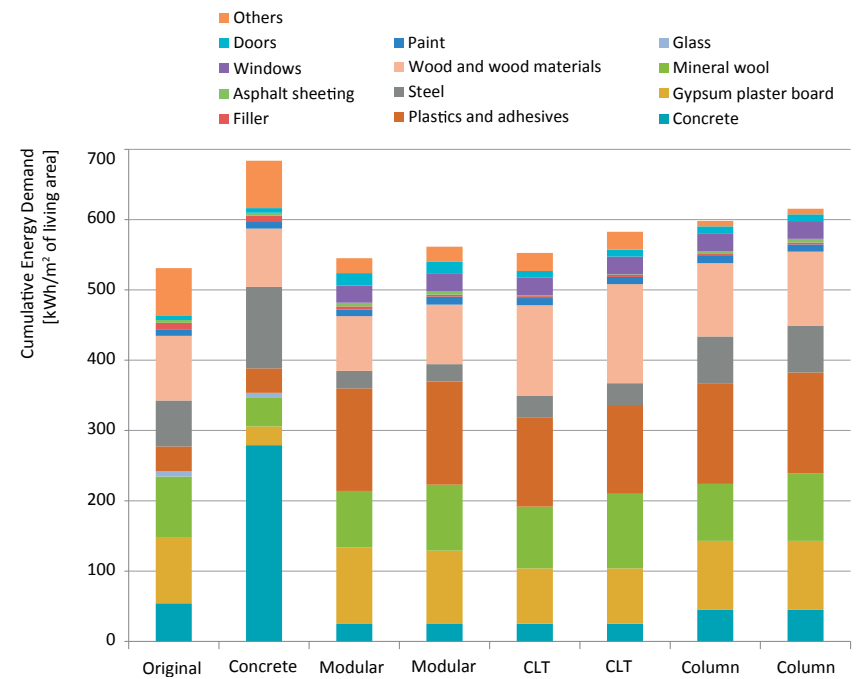

Non-renewable energy demand for the production phase F.8.2-19

8.3

4 Holz

Mietraching, Germany

Client	B&O Parkgelände GmbH & Co.KG
Architect	Schankula Architekten/Diplomingenieure
Structural engineers	Bauart Konstruktions GmbH + Co.KG
Construction company	Huber&Sohn GmbH & Co.KG

F.8.3-1



F.8.3-2

KEY FIGURES

Gross floor area	726	m ²
Net floor area	615	m ²
Living area	488	m ²
Gross volume	11 928	m ³
Net volume	9 459	m ³
Nr of occupants	24	persons
Planned service life	50	years

F.8.3-1 The building in its environment

F.8.3-2 Key figures of the building

A. Takano

This building is a four-story apartment building located at a former military site in Mietraching, approximately 50 km south-east of Munich. The area was bought by B&O, a real estate developer, and redevelopment was planned as a “zero-energy/emission” model city.

Most of the existing buildings on the site were deconstructed because of pollution with harmful substances. However, since the basement, which was originally a bunker with a thick wall, was in relatively good condition, it was utilized for new construction. Wood construction was selected because of its lightness for the existing basement structure, ecological aspect, high level of prefabrication and short construction period. This project demonstrated that wood can be used as the primary structural component for multi-story dwellings.

As a common problem with wood constructions, fire safety and sound protection were the main challenges in this project. For fire safety reasons, the load bearing structure is required as an REI60. This criterion is achieved with K260 encapsulation that consists of two layers of gypsum fibre board with 18mm thickness each as an interior layer. The exterior wall is required to be made from non-combustible materials by the fire regulations. The solution

was a closed cladding with horizontal fire stops at each storey. For sound protection, the massive glulam ceilings with 200 mm of thickness are finished on top with a layer of gravel and a dry screed system that consists of a soft wood fibre board and a double layer of gypsum fibre board. There is no additional demand for a suspended ceiling for sound protection purposes.

The building is a simple box shape with a balcony made of LVL. All wooden building elements were prefabricated by Huber&Sohn GmbH&Co.KG. The on-site assembly of prefabricated elements took just four days.

For the conditioning of the indoor environment, a heat recovery ventilation system and radiation connected to the district heating system are used.

Buildings from the developer located in the area were designed at a high-energy standard (energy demand should be 50% of EnEV 2009). In addition, several measures were been conducted in order to optimize the environmental impact from energy production, such as modernization of the existing boiler for district heating, a district solar thermal collector, re-heating system with heat pumps for hot water, a biomass boiler, photovoltaic panels, and a small hydroelectric power plant.

F.8.3-3
Ground floor plan, 1:400

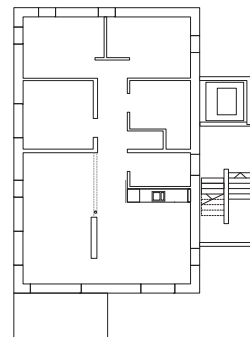

F.8.3-4
Upper floor plan, 1,400

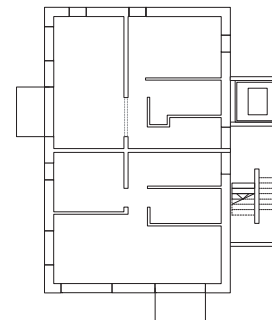

F.8.3-5
Section, 1:400

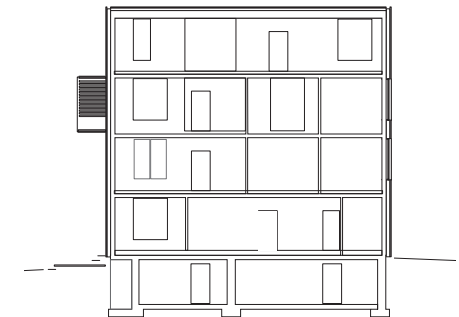

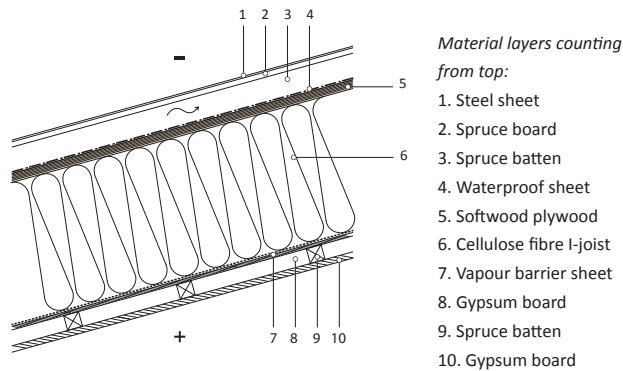

F.8.3-6
Roof detail, 1:10

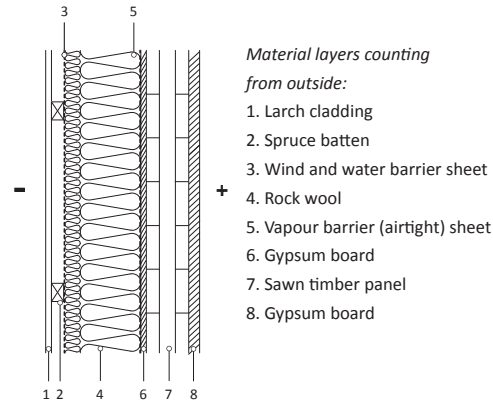

F.8.3-7
Exterior wall detail, 1:10

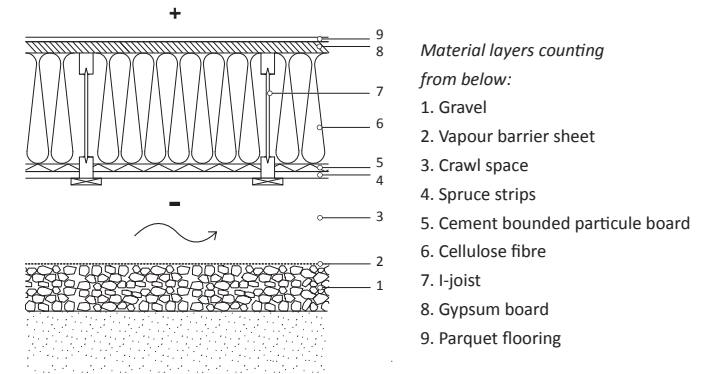

F.8.3-8
Base floor detail, 1:10

Assessment

For the production stage, module A, all calculations were conducted manually with the help of templates created in this project. For the use stage, module B6, the energy demand for operation of the building was calculated based on the standard (DIN4108-6/EnEV2009 by LCA software LEGEP. In addition, the energy content of wooden materials was calculated with an equation mentioned in the ecoinvent database documentation [1]. Carbon storage capacity of wooden material was also calculated according to the standard (CEN/TC175 W100175146). The other life cycle modules are excluded from the assessment due to lack of data.

Module A

All information regarding building components was collected from the drawings. Since it was impossible to assess the existing basement directly, a new basement with the same shape as the existing one was assumed and included in the study. Regarding the construction process, prefabrication and on-site assembly of the building elements were covered based on an interview with the constructor. In addition, earthwork and the construction of the basement were assessed by referring to the case study of Joensuu Elli, since the detailed data could be collected in that study. Electricity use for on-site construction is not included due

to a lack of data. In this module, all building service and machinery are excluded from the calculation due to a lack of information.

Energy performance

Module B

Operational energy use was assumed to be 31,83 kWh/m²/year for district heating and 31,31 kWh/m²/year for electricity use in the whole building. As mentioned before, this area is very unique regarding energy production, so it was not possible to specify the real energy mix of district heating system in the area. Therefore, the general German situation was referred to. Mainly the heat comes from CHP plant, which consists of approximately 42% natural gas, 39% coal, 12% lignite, and 7% waste incineration (AGFW 2006). This energy mix was used in the calculation. For the electricity, national average data on supply mix was applied.

Data

ecoinvent ver. 2.2 was used in all calculations. ecoinvent is one of the most well-known LCA databases that consists of process-based LCI data. Geographical coverage is mainly in Europe. Temporal representativeness is the year 2000-2007 as the annual average. Basically stored data is based on an average of currently used

technology. In this study, European average data is applied for the calculation of A1-3, and German average data is applied for A4-5. In principle, exact material data was applied for building materials from the database. However when there was not exact data in the database, the most relevant material data was applied (i.e., plywood data instead of LVL).

Structures and construction methods

Foundation and floors

The existing basement was utilized as the main foundation and an additional foundation was made for the staircase. The floor of the ground floor consists of three layers on top of the basement: rock wool, cement screed, and parquet flooring. The intermediate floor consists of five layers: glulam panel, gravel fixed by latex, mineral wool, cement screed, and parquet flooring. Only the glulam panel slab was prefabricated in a factory, and the other layer was installed on-site.

External walls

The exterior wall consists of eight layers as shown in the section. The U-value is 0,15 W/m²K. This element was prefabricated and assembled on-site in three weeks including secondary work

F.8.3-9
 Assembly of the staircase, Mietraching



F.8.3-10
Primary energy demand
 MJ/m² of living area
 Life cycle phases A1-5 and B6

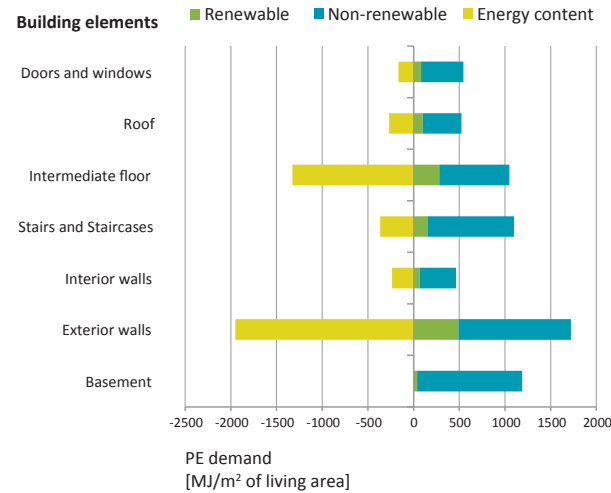

(covering, airtightening, etc.). Some of the installation has been done on-site, such as the entrance door and the window facing the balcony.

Roof

The roof element is composed of six layers, as shown in the section. Above PVC waterproof sheet and finishing of ceiling (plywood) have been installed on-site. The U-value is 0,14 W/m²K.

Other structural features

The load-bearing structure of the wall element consists of a massive timber layer, which is literally a mass of sawn timber laid side by side and fixed with a nail to the LVL frame. Gypsum board is also attached from both sides of the massive timber layer to tighten those and for fire resistance.

F.8.3-11
GHG emissions
 kgCO₂e/m² of living area
 Life cycle phases A1-5 and B6

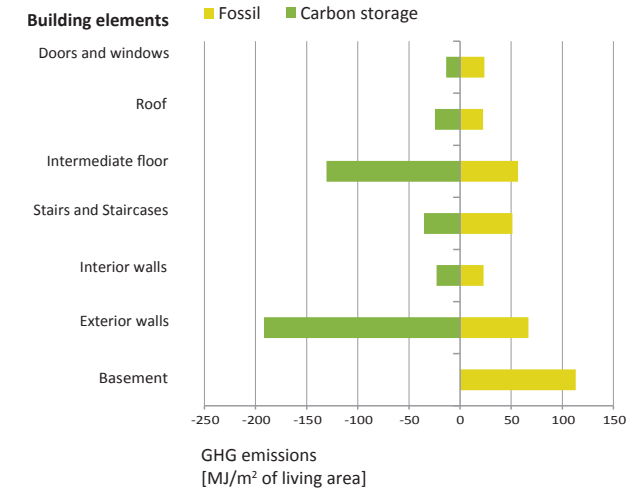

Construction work

Prefabrication

All wooden building elements were prefabricated in the factory. This prefabrication work was done in about one month. The prefabrication company also produces window and door products in its factory. All wood waste from the prefabrication process is burned in the factory's biomass boiler, and generated heat is utilized for drying wood and for space heating in the factory.

The exterior steel staircase was also prefabricated in a factory. However it was excluded from this study due to lack of information.

On-site work

On-site construction work is mainly assembly of the prefabricated element. It was done in three weeks. After that, interior finishing and water-proofing work was done. These on-site finishing works were excluded from this study because of lack of information. The assembly of the steel staircase is included based on an assumption.

ENERGY PERFORMANCE

Operative energy use	30 812,32 kWh/a
	63,14 kWh/m ² /a
Heat generation	District heating
Heat distribution	Radiator
Air tightness	0,6 h ⁻¹
Energy class	EnEV2009

Results

Primary energy balance

Use phase energy, module B6, accounts for 70% of total primary energy consumption for module A and B6. The construction process, module A4-5, contributes a very minor impact, about 5% of the total. Energy content is about 4 000 MJ/m² of living area, which can cover all energy consumption for the construction phase.

Carbon footprint

The same trend is shown in the carbon footprint as the primary energy balance. 70% of GHG emissions originate in module B6, and the production phase emits about 30% of the total. Carbon storage capacity is about 428 kgCO₂e/m² of living area, which corresponds to more or less the same amount of GHG emissions from module A.

CARBON FOOTPRINT (A1-5, B6)

kgCO₂e

	<i>per m² of living area</i>	<i>per whole building</i>
Carbon footprint	1 572	767 150
Carbon storage	-428	-208 922
Net balance	1 144	558 228

Other findings

The basement is the dominant building element regarding the carbon footprint due to its volume for the material production phase (A1-3). In addition, the basement is used as a storage and machine room, which are not included in the living area. Therefore, the result normalized by m² of living area shows a relatively high value for the production phase. The exterior wall element is the main for primary energy consumption, but on the contrary, it has the largest carbon storage capacity and energy content.

Conclusions

LCA has been conducted for the material production, construction, and operation phase of the building. The main feature of this case study is to conduct detailed data collection for the construction phase, module A4-5. Based on the collected data, the relation between the material production phase and the construction phase for wooden building elements is studied with the two other case studies (see Section 5.4). Actually, the study encountered difficulties in data collection from the construction process.

PRIMARY ENERGY USE (A1-5, B6)

MJ

	<i>per m² of living area</i>	<i>per whole building</i>
Total	26 825	13 090 811
Renewable	1 632	796 587
Non-renewable	25 193	12 294 224
Energy content	-4 029	-1 966 000

Proper data collection is required in order to understand the environmental profile of the process. But it is not so easy in the current industrial situation. Further research and development of a practical LCA method for the construction process with reliable quality and ease is important as a next step.

Accuracy of inventories for the assessment of module A1-3 is also an important feature of this study. The amount of each building components were taken off from the detail drawings and material order information given by the constructor as precisely as possible. Therefore, detailed inventories could be made.

In this study, all building service equipment is not included due to lack of information. Building service equipment would have a significant influence on the life cycle environmental impact, especially due to its maintenance. This issue needs to be investigated more.

8.4 Austrian buildings

F. Dolezal, O. Mair am Tinkhof, H. Mötzl, C. Spitzbart

The aim of the Austrian case studies was to analyse primary energy input and CO₂ emissions over the life cycle of very energy efficient residential buildings (Passive houses and Nearly Zero Energy Buildings – NZEB). Three existing buildings that represent typical residential buildings according to the Austrian building typology (developed within the EU project TABULA [Amtmann, Gross 2011]) have been chosen for this analysis. However, the wood construction systems they incorporate are quite innovative and not yet common in Austria.

The multi-storey and the single family building have been built according to the Passive House standard (heating demand of less than 15 kWh/m²a according to PHPP calculation software), while the row house was originally designed as a Low Energy House with an average heating demand according to Austrian building regulations. Within the project, the row house has been virtually changed into a Nearly Zero Energy Building by the use of PV cells. The buildings are supplied with different heating systems but are all equipped with mechanical ventilation with heat recovery.

Multi-storey building, Mühlweg, Vienna

Client BAI Bauträger Austria Immobilien GmbH
Architect Dietrich | Untertrifaller architects
Construction company KLH Massivholz GmbH

Row house, Steinbrechergasse, Vienna

Client Glorit Bausysteme AG
Construction company Glorit Bausysteme AG

Single family house, Schönkirchen

Client Nicole and Michael Hartl
Architect Planungsbüro ARE-Bau GmbH
Construction company Ing. Graf Zimmerei und Holzbau GmbH



F.8.4-1

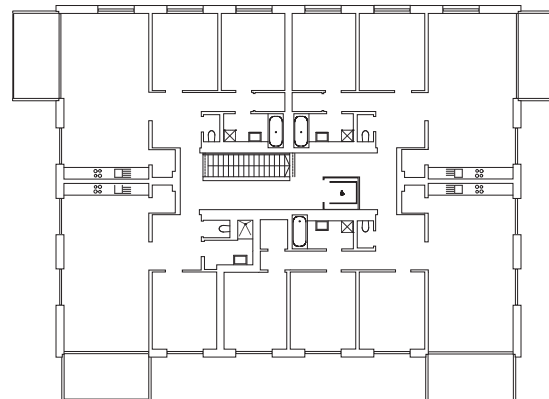

F.8.4-2



F.8.4-3

F.8.4-1 Multi-storey residential building, Vienna

F.8.4-2 Ground floor plan, 1:400

F.8.4-3 Section of the building, 1:400

General assumptions for the assessment and the database used are described at the end of this chapter.

8.4.2 Multi-storey residential building, Vienna

The first presented building (Dietrich | Untertrifaller architects) is a multi-storey residential building located in Mühlweg, Vienna. The apartment complex consists of four blocks comprising 70 flats for approximately 200 inhabitants in total. The project was the winner of a developer and architect contest launched by the City of Vienna and Holzforschung Austria (HFA). It was erected within the financial means of the social housing fund.

The residual heat is provided by a combined solar/gas heating system. All apartments are supplied with fresh air by a central ventilation system.

The basement, the staircase and the load-carrying system of the first floor are made of concrete; the three upper floors and the attic floor show a massive wood construction.

The calculation at hand considers one block, including the proportionate basement.

Structures and construction methods

The characteristic structure of the building is a cross laminated timber (CLT) construction.

Foundation and floors

The building is grounded on a foundation slab made of reinforced concrete, which is based on lean concrete and gravel and equipped with a bitumen coating and 22 cm interior EPS insulation where applicable.

The basement ceiling is made of concrete, all other ceilings are based on cross-laminated timber panels.

The floor construction consists of floor covering and cement screed on glass wool sound insulation and split filling. Gypsum

plaster board panels on adj. strap hangers form the bottom boundary of the ceiling. The basement ceiling is insulated with 36 cm stone wool.

External walls

External walls are made of a prefabricated cross-laminated wood construction with mineral wool between wooden lathes as insulation material. The exterior side of the wall is covered with wood or plastered wood wool panels.

The basement walls consist of 25 cm reinforced concrete with bitumen coating and 5 cm extruded polystyrene foam insulation.

Roof

The flat roofs are also made of CLT. The insulation layers are carried out as a duo roof or as non-ventilated terrace.

Other structural features

- There are several types of wooden inner walls: CLT panels, double CLT panels with mineral wool in between, or wooden frame filled with mineral wool.
- Windows with wooden frames and 3 layer thermal insulation glazing fulfil passive house standard.
- Concrete made inner walls are simply plastered or planked with gypsum plasterboards, respectively, depending on the requirements from building physics.
- Staircases are made of prefabricated concrete.

Construction work

Prefabrication

The building structure exhibits a high degree of prefabrication. All essential structural parts as external walls, floors and roofs

KEY FIGURES (one block)

Gross floor area	2 052	m ²
Living area	1 565	m ²
Gross volume	5 269	m ³
Net volume	4 269	m ³
Nr of occupants	50	persons
Planned service life	50	years

ENERGY PERFORMANCE

Operative energy use	74 320 kWh/a
	36,2 kWh/m ² /a
Heat generation	Ventilation system, solar/gas heating system radiator
Heat distribution	Ventilation system, radiators
Energy generation	-
Air tightness	0,3 h ⁻¹
Energy class	Passive house

F.8.4-4 Key figures for one block

F.8.4-5 Energy performances of the building



are made of prefabricated cross-laminated timber. The external walls were delivered to the site including all windows and façade.

On-site work

Because of the high degree of prefabrication, on-site works are reduced to completing and connecting prefabricated components, supplemental to the interior and landscaping.

8.4.3 Row house, Steinbrechergasse, Vienna

The second presented building is a row house with a gross floor area of 668 m² and a net floor or living area of 531 m², considering all five housing units. All units are equipped with a basement below the entire ground floor. The whole settlement is located in Vienna, Austria, in green surroundings with single family houses.

The whole building originally was designed as a Low Energy House with an average heating demand according to Austrian building regulations. Since one of the fundamental goals of the research project was to determine the environmental impact of Nearly Zero Energy buildings, the whole existing construction was adapted and transferred to a passive house structure with the additional application of PV cells on the roof. Therefore all

KEY FIGURES

Gross floor area	668	m ²
Living area	531	m ²
Gross volume	2 143	m ³
Net volume	1 335	m ³
Nr of occupants	20	persons
Planned service life	50	years

From left to right

F.8.4-6 The building in its environment, Vienna

F.8.4-7 Key figures of the building

F.8.4-8 Energy performances of the building

ENERGY PERFORMANCE

Operative energy use	40 240 kWh/a
	60,3 kWh/m ² /a
Heat generation	Central heating pellet boiler
Heat distribution	Ventilation system, radiators
Energy generation	Photovoltaics (151m ²)
Air tightness	0,6 h ⁻¹
Energy class	Passive house

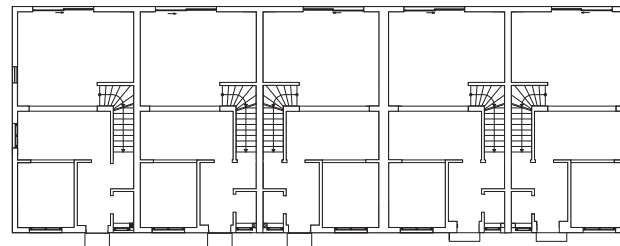

From left to right

F.8.4-9 Plan

F.8.4-10 Section

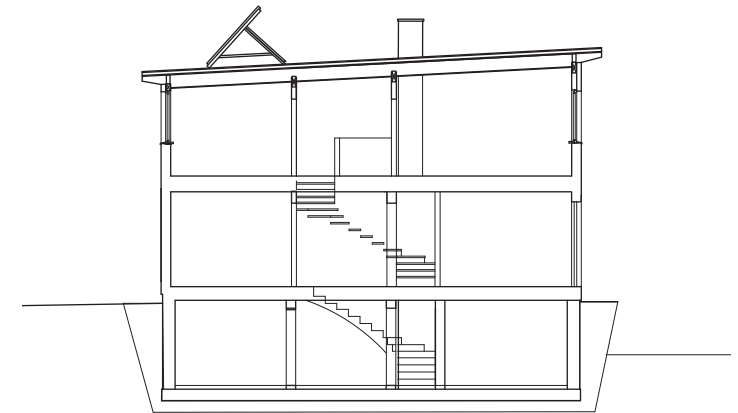

exterior elements (roof, walls, windows and ground floor slab) were thermally improved by raising the thickness of insulation material. Moreover, the building had to be equipped with a ventilation system with heat recovery.

Structures and construction methods

The structural system of the row house is a wooden post and beam structure with an external thermal insulation composite system (ETICS). The structure is based on a basement made of XPS-insulated concrete walls with a foundation slab of reinforced concrete.

Foundation and floors

The row house is equipped with a basement on a ground slab. The ground slab is a reinforced concrete slab on poor concrete and gravel with insulation and a screed.

The ground floor slab is made of reinforced concrete as well, but shows an impact sound insulation below the screed, insulation below to the basement and parquet or tiles. The first floor slab is a wooden beam structure with mineral wool in the cavities, a dry screed on impact sound-insulation boards.

External walls

External walls are a prefabricated post and beam structure with glass wool in the cavities and an external thermal insulation composite system made of polystyrene.

Roof

The single pitch roof is partly prefabricated and also a wooden beam structure with mineral wool insulation in the cavities and a rear ventilated aluminium roof covering.

Other structural features

Non load bearing inner walls are made of wooden studs, planked with gypsum boards. Windows are wood aluminium frames with 3-layer thermal insulation glazing.

Staircases are made of prefabricated concrete in the basement and wood in the ground floor.

Construction work

Prefabricated reinforced concrete elements are placed and backfilled. Prefabricated wooden walls, floors and roofs are placed on-site as well. Joints in already plastered external walls are filled, and aluminium covering is applied on the roof elements. Stairs are implemented and flooring is completed after setting up inner walls. The last step is to place the different types of floor coverings.

Prefabrication

In this case we can find a very high degree of prefabrication, as all essential structural parts of the row house are prefabricated: wooden components as external walls, floors and roofs as well as components made of concrete.

On-site work

Because of the high of prefabrication, on-site works are reduced to completion and connecting prefabricated components, completion of the interior and landscaping.

F.8.4-11
Roof detail

1. Roofing (aluminium sheet)
2. Ventilation cavity 80mm
3. Underlay on planking
4. Insulation between wooden beams (280mm)
5. Insulation between secondary beams (60mm)
6. Suspended ceiling

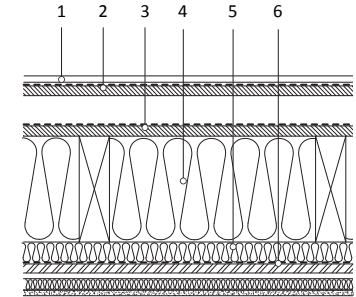

F.8.4-12
Wall detail

1. Gypsum board
2. Insulation between wooden columns (140mm)
3. Particle board
4. Polystyrene (140mm)
5. Plaster

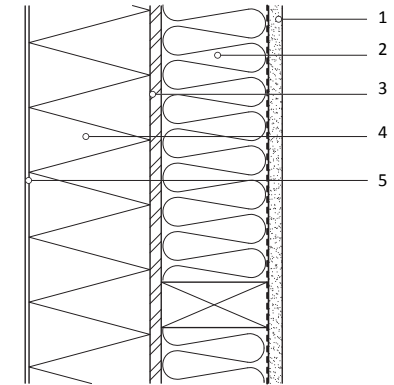

F.8.4-13
Floor detail

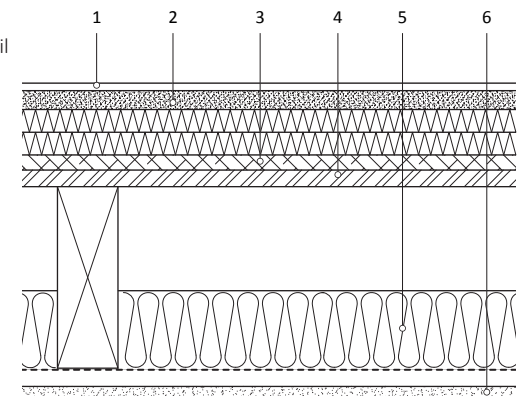

1. Parquet or tiles
2. Gypsum board
3. Footfall sound insulation
4. OSB
5. Insulation between beams
6. Gypsum board

8.4.4 Single family house, Schönkirchen, Lower Austria

The third presented building, built by Ing. Graf Zimmerei und Holzbau GmbH, is a single family house with a gross floor area of 290 m². The building has no basement, but about 80 m² of the mentioned area is used as a garage and storage room. The remaining 70% is used as living area. The garage and the living area are connected and accessible via a central porch.

The living area of the building was built as a solid wood construction. Stone wool is used as insulation material. The garage is a brick construction of only one floor and not conditioned.

The living area is divided into two floors and was designed for a family with two adults and two children.

The building is located in the small village of Schönkirchen, about 40 km north-east of Vienna and about 160 m above sea level. To generate heat, an air/air heat pump is used. For the heat distribution, the house is provided with a mechanical ventilation system with heat recovery.



F.8.4-12
The building in its environment

KEY FIGURES

F.8.4-13

Gross floor area	290	m ²
Living area	161	m ²
Gross volume	885	m ³
Net volume	760	m ³
Nr of occupants	4	persons
Planned service life	50	years

ENERGY PERFORMANCE

F.8.4-14

Operative energy use	2 923 kWh/a
	13,9 kWh/m ² /a
Heat generation	Heat pump
Heat distribution	Ventilation system
Energy generation	-
Air tightness	0,11 h ⁻¹
Energy class	Passive house

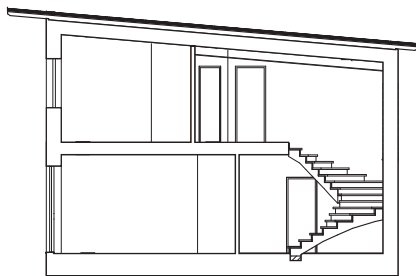

F.8.4-15
Section

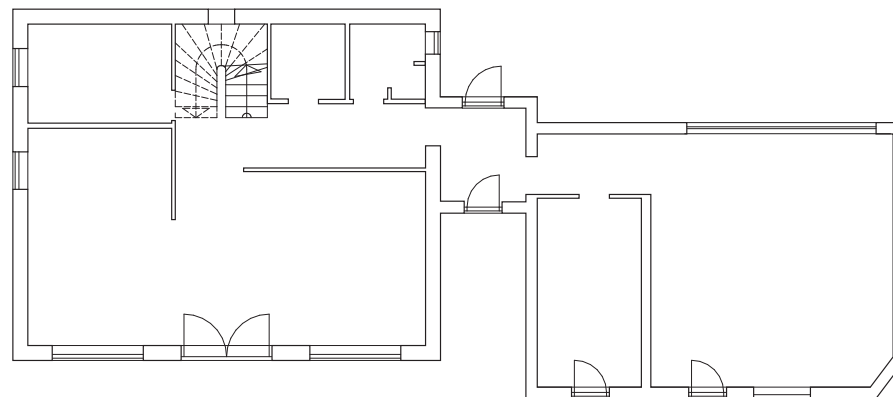

F.8.4-16
Plan

Structures and construction methods

Foundation and floors

The construction of the foundation consists of reinforced concrete with XPS and EPS insulation. In the residential building, wood parquet is used as flooring in almost all rooms. In the garage, tiles are laid.

External walls

The external walls of the residential building are built as a solid wood construction with stone wool insulation. The thickness of the construction is 42 cm. The U-value is 0,13 W/m²K. The external walls of the garage consist of 16 cm of bricks. As the garage is not conditioned, no thermal insulation was attached to the external walls. The share of the external garage walls to the total external walls is about 40%.

F.8.4-17
Intermediate floor detail

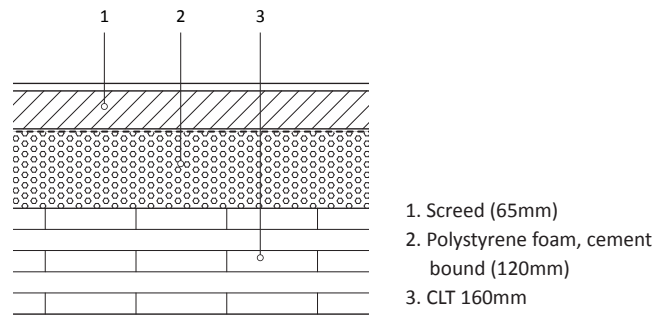

Roof

The roof of the residential building consists of timber rafters and stone wool. The flat roof has a thickness of 42 cm and a U-value of 0,12 W/m²K. The roof of the garage consists of concrete (18 cm) and EPS insulation (10 cm).

Other structural features

The internal walls are built as lightweight timber constructions in the residential building and as solid brick construction in the garage. The rendering of the internal walls consists of loam on reed matting. The inner ceiling is made of cross laminated timber panels.

The stairs and door and window frames are also made out of wood. Windows are equipped with 3-layer thermal insulation glazing. The windows have a U-value of about 0,7 W/m²K (depending on the area and orientation).

F.8.4-18
Wall detail

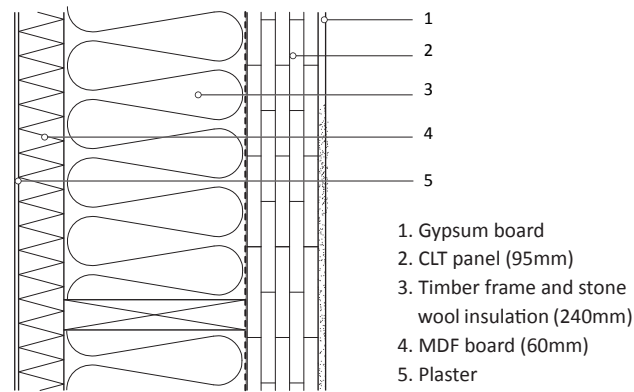

Construction work

The construction works were carried out by a small-sized carpenter company with major input from the building owners.

Prefabrication

All essential structural parts of the external building shell (walls including windows, roof) are made of prefabricated cross-laminated timber. They were delivered to the site where they have been completed with a special focus on airtightness.

On-site work

Because of the high of prefabrication, on-site works are reduced to completion and connecting prefabricated components. The internal walls have been built directly on site, adding the reed matting and loam rendering. Also the garage was brought up directly on the site.

F.8.4-19
Roof detail

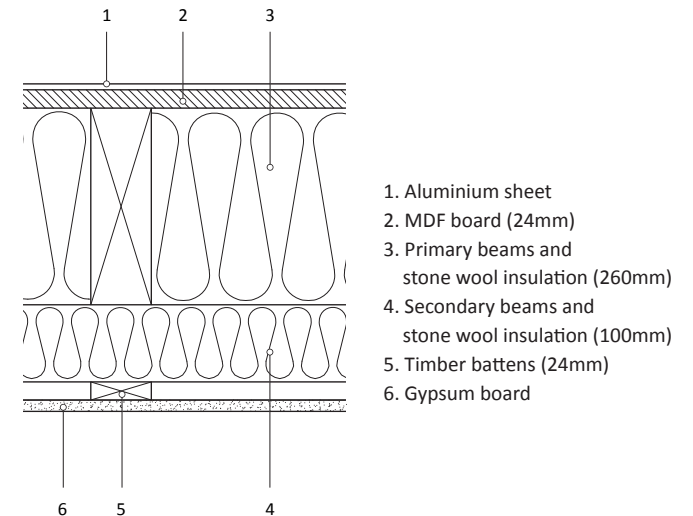

PRIMARY ENERGY USE

MJ

F.8.4-20

Total

Non-renewable, total

Renewable

Renewable energy content

Substitution (module D)

	Multi-storey building		Row house		Single family house	
	per m ² of living area	per whole building	per m ² of living area	per whole building	per m ² of living area	per whole building
Total	28 110	40 956 714	27 750	14 735 480	16 534	2 665 680
Non-renewable, total	22 136	32 100 998	14 136	7 506 063	14 153	2 281 670
Renewable	2 809	4 396 215	15 646	8 308 197	6 202	999 875
Renewable energy content	3 165	4 459 501	2 032	1 078 780	3 820	615 865
Substitution (module D)	-3 419	-5 350 232	-2 437	-1 294 253	-4 488	-723 552

CARBON FOOTPRINT

kg CO₂e

F.8.4-21

Carbon footprint

Carbon storage

Net balance

Substitution (module D)

	Multi-storey building		Row house		Single family house	
	per m ² of living area	per whole building	per m ² of living area	per whole building	per m ² of living area	per whole building
Carbon footprint	2 097	3 282 438	1,117	593 252	1 427	230 056
Carbon storage	314	491 757	277	146 950	357	57 573
Net balance	1 783	2 790 682	840	446 301	1,070	172 483
Substitution (module D)	-178	-279 259	-127	-67 554	-269	-43 360

8.4.5 Results

The figures show a comparison of the life cycle phases and building elements of the multi-storey building (MSB), row house (RH) and single family house (SFH). However, when comparing the results, the following must be considered:

- The SFH has an adjoining garage instead of a basement. Impacts of the garage walls, roof, etc., are included in the corresponding building element categories (exterior walls, roof, etc.)
- B6 (energy use) of the row house also includes electricity use for household applications, while for the other two buildings this is not included. The electricity use of the row house is almost entirely covered by the PV plant.

- To calculate the primary energy of MSB and SFH materials, upper heating values were used, while for the SFH, lower heating values were considered.

Production phase

For all three buildings, the basement or foundation has the largest impact in terms of primary energy and GHG emissions, followed by floors and interior ceilings, the roof and exterior walls. However, the energy input for the basement is almost entirely non-renewable, while the other elements store significant amounts of carbon and include a higher share of bonded energy, which can be recovered at the end of the life cycle. (See carbon storage, biogenic emissions in phase C and substitution of natural gas in phase D). This can be considered as the advantage of wood as a construction material.

F.8.4-22

Primary energy demand per phases of life cycle

MJ/m² of living area

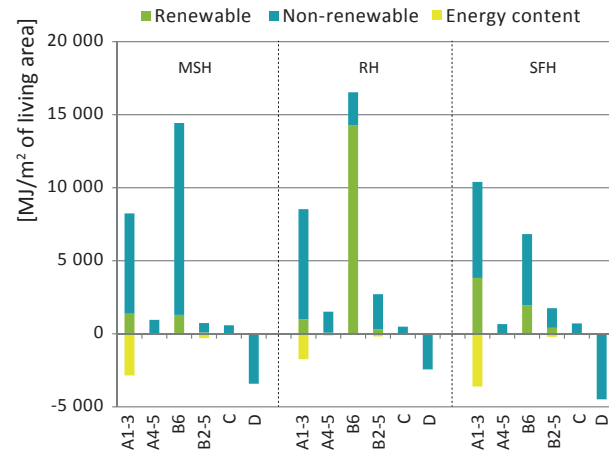

F.8.4-24

Primary energy demand

MJ/m² of living area

Production phase (A1-A3)

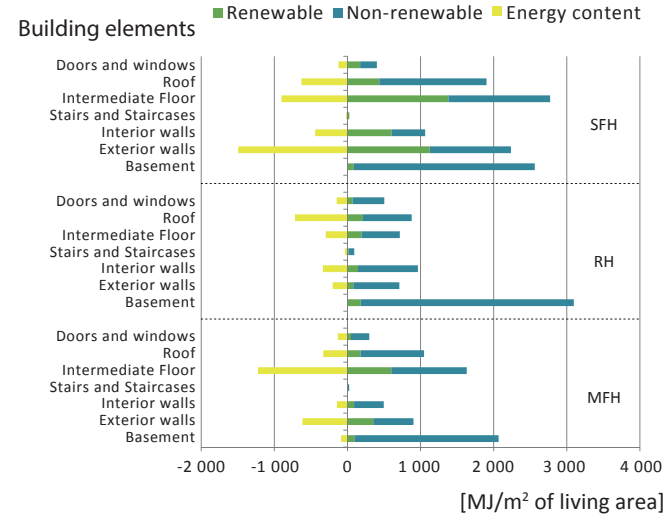

F.8.4-23

Carbon footprint per phases of life cycle

kgCO₂e/m² of living area

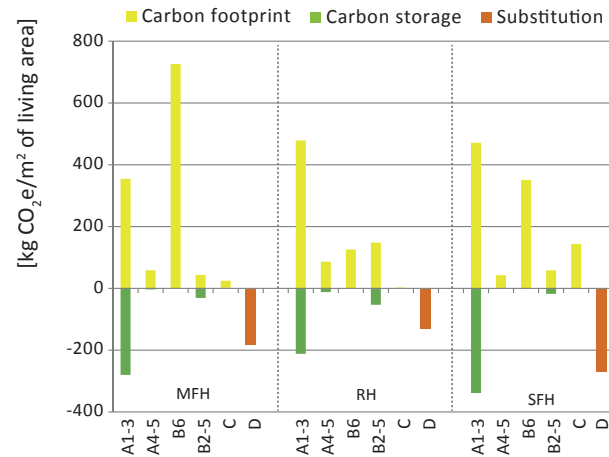

F.8.4-25

GHG emissions

kgCO₂e/m² of living area

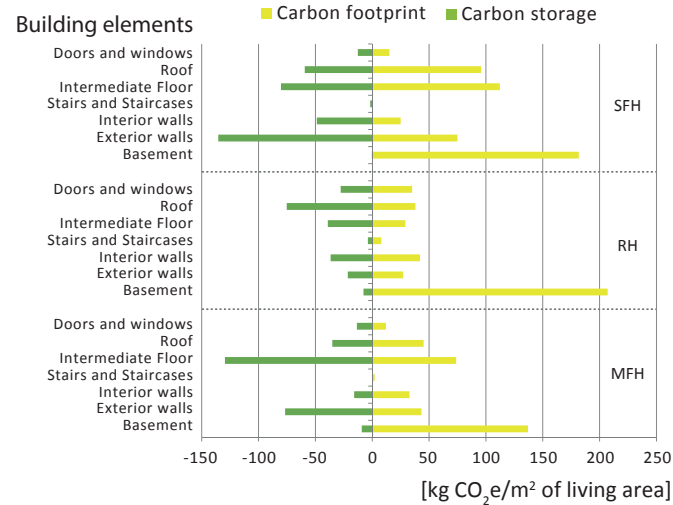

Primary energy demand

MJ/m² of living area

Production phase A1-3

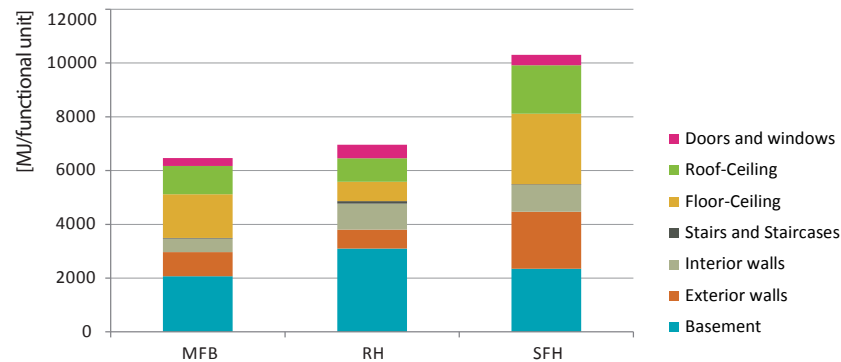

Generally more carbon is stored in the massive wooden constructions of the MSB and the SFH than in the wooden frame structures of the RH. In all three buildings, the non-renewable primary energy use and the GHG emissions caused by the walls and roof are increased due to the use of mineral or glass wool and polystyrene as insulation materials. This is especially important for the wooden frame structures since the cavities are filled with glass wool. Alternative insulation materials like cellulose fibres could improve these indicators.

Building service installations are not significant in case of the MSB (gas and solar heating, central ventilation system) and the SFH (heat pump, central ventilation system). In case of the row house, the PV plant (consisting of a 151 m² collector, inverter, electric installations and fastening system for the roof) has an impact of almost 30% of the total primary energy input in the production phase. However, so far there is little data available for building service installations and their ancillary materials. Therefore results are subject to large uncertainties. More reliable information on building service installations could significantly improve knowledge about the impact of that part of the building's life cycle.

When comparing the building concepts of a multi-storey building, row house, and single family house in terms of primary energy demand per m² in the production (and also maintenance) phase, it is obvious that the dense concept of MSBs is the most efficient one.

Maintenance phase

Due to the assumption of a 50-year service life, the replacement of materials covered in phase B4 is not very significant. This is due to the assumption that only windows, outside sealing and surface coverings, floor covering and HVAC get replaced once in this period. For all other materials and elements an assumed service life of 50 years and longer is foreseen.

Maintenance is therefore most significant for the row house as the energy intensive produced PV plant is exchanged once within the 50-year period.

An assumed service life of 100 years significantly increases the primary energy input and GHG emissions for phase B2-5 to a higher level than the production phase (A1-A3). In that case, the production and maintenance phase together may become more important than the energy use of the building. This is a strong

indicator that building materials have to be a focus of energy efficient building concepts in the future.

Energy use

The three buildings are equipped with different building service systems. This has a significant impact on phase B6 (energy use) of the life cycle. The MSB is equipped with a central gas boiler and a solar thermal system, which reduces the demand for gas. Nevertheless the non-renewable primary energy demand is quite high compared to the other buildings. The SFH is heated by a heat pump. The electricity mix is the European UCTE mix.

The row house has been designed as a Nearly Zero Energy Building (NZEB) according to Austrian definitions. The PV plant has therefore been designed to cover most of the non-renewable primary energy demand of the building for heating, ventilation and household appliances. Nevertheless the total primary energy demand (largely renewable from pellets) for heating and sanitary hot water production is quite high compared to the other buildings. This is due to the seasonal efficiency of the small scale pellet boilers used for heating and sanitary hot water production. On the contrary, GHG emissions in phase B6 are significantly lower

for the row house. This again adds to the future importance of building materials and construction methods (represented in phases A1-3 and B2-5).

8.4.6 General assumptions for Austrian buildings

Assessment

For Austria the life cycle of three buildings (multi-storey house, row house, and single family house) has been assessed. The assessment is based on a mass balance according to the construction details and a generic data set (see “data”). The building data are gathered from the permission drawing, construction catalogue and energy calculation. Gross area was used as a measurement for exterior construction details, net area for inner walls and ceilings.

The assessment of the buildings is divided into the life cycle phases A to D according to EN 15978.

The data of the materials are aggregated from cradle to gate (A1-A3) and include all processes from extraction of raw materials to manufacturing of the product.

Transport from factory gate to site (A4) is carried out by lorry (28 tons), and distances depend on materials and products considering average transport distances of building products in Austria. For the construction process of the building on site (A5) only digging, evacuation of excavation material and refilling with gravel was considered. The amount of material losses was calculated according to Takano (2011). The manufacturing of materials substituting the losses was assigned to life cycle phase A5 and the corresponding transportation needs to A4.

The energy demand for heating and warm water use in the use phase (B6) was calculated according to the Austrian energy performance certificate for buildings.

Replacement of building products (B4) was considered; all other B phases (maintenance, repair and refurbishment) were disregarded. Service life depends on material, but mainly on the function of the product, the environmental and socio-economic conditions. In

the study at hand, the used reference service life for the materials follows a very simple concept, depending on the function of the product:

- Load carrying construction: 100 years
- Windows, outside sealing and surface coverings, floor covering, HVAC: 25 years
- All other materials: 50 years

Deconstruction and transport from site to waste treatment (C) is taken into account and depends on the material.

For module D (benefits and loads outside the system boundary), a typical scenario for the Austrian situation of waste wood treatment is applied. Waste wood is burned in an industrial waste co-incineration plant (for heat) with an efficiency of 90%. This amount of energy is substituted by gas, considering a boiler efficiency of 95%.

Primary energy is calculated using the higher heating value. The GWP is calculated according to IPCC 2007, all other LCIA indicators (not published here) according to CML 2001 v1.05. The calculations have been carried out using ECOSOFT v3.4.2 software.

Data

For all relevant processes (building materials, transportation and energy systems as well as for disposal processes) the IBO database 2008 (updated version Oct. 2010) was used.

System boundaries of the generic data for materials are cradle to gate (A1-A3). Basic data for standard processes such as energy systems, transport systems, basic materials, forestry, disposal processes, and packaging materials are obtained from Ecoinvent data v2.1. Some additional generic data for raw materials and intermediate products have been established by IBO in the course of product assessments and research projects. All data use the UCTE mix from Ecoinvent data v2.1 as electricity source, independent of the actual electricity source. Thermal processes are also modelled

with European modules from Ecoinvent. Biogenic CO₂ emissions are considered to be carbon-neutral by Ecoinvent and are therefore not included in phases A and B. They can only be shown in phase C of the life cycle. In case allocation cannot be avoided, economic allocation is chosen. More details on the assessment methods can be found in IBO (2009).

8.5

JOENSUUN ELLI

Joensuu, Finland

Client Opiskelija-asunnot Oy Joensuu Elli
 Architect Architect: Arcadia / Samuli Sallinen
 Construction company Rakennustoimisto Eero Reijonen Oy



KEY FIGURES

F.8.5-1

F.8.5-2

Gross floor area	730	m ²
Net floor area	695	m ²
Living area	548	m ²
Gross volume	6 964	m ³
Net volume	6 185	m ³
Nr of occupants	20	persons
Planned service life	50	years

A. Takano

The building is located in Joensuu in the south-east part of Finland. This building is a two-story student apartment planned by Opiskelija-asunnot Oy Joensuu Elli. One building block consists of 16 room units and two machine rooms located in an attic. Six building blocks have been constructed at the place of an old student apartment with several common facilities.

The CLT panel is the main structural element, which was provided by Stora Enso and prefabricated by Eridomic Oy. The main

contractor of the on-site construction was Rakennustoimisto Eero Reijonen Oy.

Since construction work has been running parallel with the research project, detailed data collection from those construction processes could be conducted. Data regarding energy consumption and material flow during the prefabrication process has been collected in Eridomic's factory. On-site construction has been monitored daily by a researcher from Stora Enso.

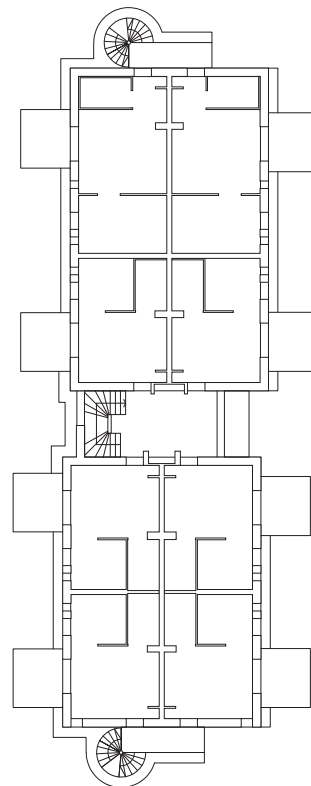

F.8.5-3

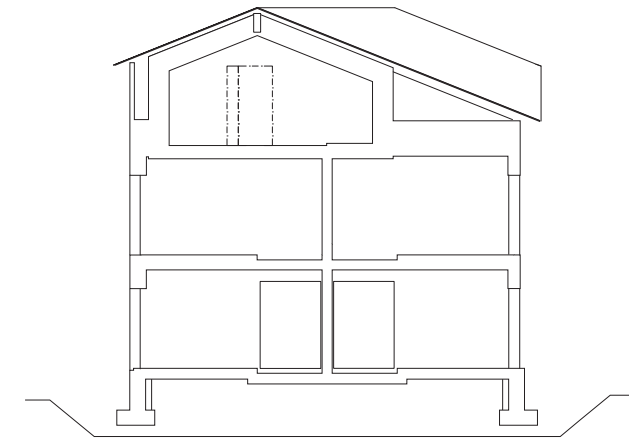

F.8.5-4

F.8.5-1 The building in its environment

F.8.5-2 Key figures of the building

F.8.5-3 Ground floorplan, 1:400

F.8.5-4 Section, 1:400



F.8.5-5
Exterior view of the building

Assessment

This study covers the product stage, construction stage, and use stage (only operational energy use) of one building block (module A1-5 and B6). Detailed data collection has been conducted for both off-site and on-site construction works. All calculation was conducted manually with the help of templates created in this project. In addition, the energy content of wooden materials was calculated with an equation mentioned in the Ecoinvent database documentation/1/. The carbon storage capacity of wooden material was also calculated according to the standard (CEN/TC175 WI00175146).

Module A

All information regarding building components was collected from the detail drawings. The calculated mass of each component was cross-checked with the material order list provided by Eridomic Oy. The building service, furniture, and landscape around the building are excluded from the assessment due to lack of information.

Regarding the construction process, the prefabrication of wooden building elements, on-site earthwork, concrete foundation making, and assembly of the prefabricated building elements were covered based on the monitoring of construction work and interview with the constructor. Interior finishing, roof water proofing work,

building service installation, and assembly of the balcony were excluded from the assessment because of the time schedule and lack of data. For the prefabrication process, included inventories are electricity for the operation of the factory (machinery, lighting, ventilation) and space heating energy generated by a biomass boiler in the factory. For on-site work, included inventories are electricity for operation of the construction infrastructure and machine, and diesel for the construction machine. Transportation of building component and element were included according to the real situation. Waste from the prefabrication factory and construction site was also taken into account. Workers commuting to the factory or construction site were not covered.

Module B6

Operational energy use was assumed, based on the result of the calculation for the building permission, as 31,88 kWh/m² per year for district heating and 26,75 kWh/m² per year for electricity use. It is assumed that district heating energy and electricity are fully provided by the CHP plant. The energy mix was estimated based on the situation of the CHP plant in Joensuu and the national average value: 50% biomass, 17% natural gas, 9% coal, 18% peat, and 3% oil and waste incineration (Energiateollisuus 2013, Fortum 2013).

ENERGY PERFORMANCE

F.8.5-6

Operative energy use	32 332 kWh/a
	59 kWh/m ² /a
Heat generation	District heating
Heat distribution	Radiator
Energy generation	-
Air tightness	-
Energy class	A

Data

ecoinvent ver. 2.2 was used in all calculation. (See Section 8.3 – Mietraching case study.)

Structures and construction methods

Foundation

On top of the concrete footing, a sandwich panel (put EPS insulation between precast concrete panels) is set up as a foundation. The slab toward the ground consists of an EPS mat and a precast concrete panel on top of that. This is a typical composition of a foundation in Finland.

Floors

The intermediate floor consists of eight layers as shown in the section. This floor is like a hollow panel with a CLT slab panel, glulam beam, and OSB board. On top of the OSB, a concrete layer is cast for sound insulation. Plastic sheet flooring is installed directly on top of the concrete layer.

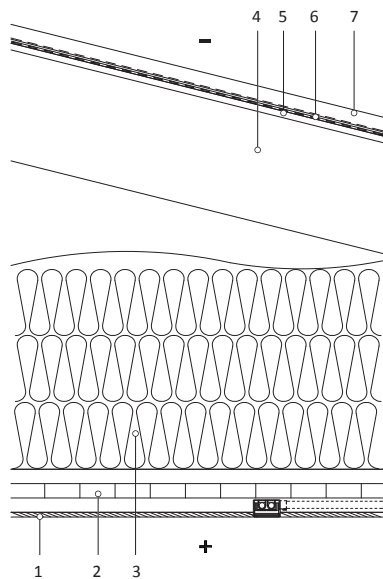

F.8.5-6
Roof detail

1. Gypsum board
2. CLT board 120mm
3. Thermal insulation 550mm
4. LVL beams
5. OSB board 18mm
6. Bituminous felt
7. Steel roofing

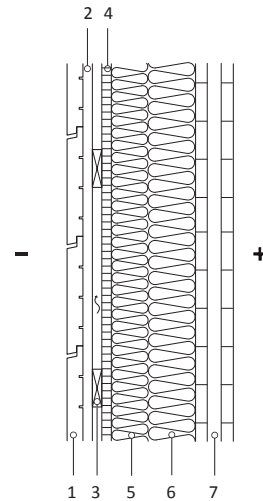

F.8.5-7
Wall detail

1. Exterior wood cladding
2. Battens (vertical)
3. Battens (horizontal)
4. Wind barrier board (LDF)
5. Mineral wool insulation 98mm
6. Mineral wool insulation 125mm
7. CLT board 100mm

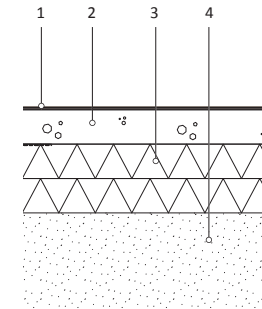

F.8.5-8
Base floor detail

1. Floor material
2. Concrete slab 100mm
3. EPS insulation 2x100mm
4. Gravel

External walls

The exterior wall consists of six layers as shown in the section. The U-value is 0,14 W/m²K. The insulation layer is divided into two layers, and just one layer has a wood stud in order to minimize cold-bridge via stud.

Roof

The roof element is composed of four layers as shown in the section. Basically the attic is ventilated (open) except for the machine room. The U-value of roof is 0,07 W/m²K.

Other structural features

CLT is main structural element and glulam/LVL beam is used for the floor and roof element. The balcony made of a CLT panel is attached on the exterior wall.

Construction work

Prefabrication

All wooden building elements were basically prefabricated in a factory. A pre-cut CLT panel was delivered from Stora Enso's

Austrian mill to Eridomic's factory in Finland and assembled with the other materials. The prefabrication factory is located in Pälkane, about 400 km from the construction site. The prefabricated building elements were delivered by truck. Window and door are installed partly on-site. Wood waste from the prefabrication process is burned in a biomass boiler, and generated heat is utilized for space heating in the factory. Working hours for the prefabrication was recorded by the company, which helped the allocation of consumed energy.

On-site work

All phases from earth work to assembly of the building element were covered. Since there are six building blocks on the site, several construction works were always running at the same time. Therefore, materials were delivered for all blocks at the same time, and construction machines were shared by each block. In addition, there was a single electricity meter on the site for all construction and the infrastructure. This would be a typical situation in construction work, which makes data collection rather difficult and complex. However, in this case, the on-site construction work was monitored daily, so it could help to allocate the material and energy flow to each construction process to some extent.

Results

Primary energy balance

The material production stage, construction stage, and use stage account for approximately 40%, 10%, and 50% of the total primary energy consumption in module A and B6, respectively. The energy content in wooden materials is two times more than the energy consumption during construction work (A4-5). It is remarkable that the transport of construction material and equipment (A4) consumed about three times more energy than the actual construction work (A5), due to the very long transportation distance of the main structural material and prefabricated building element. CLT elements were delivered from Austria to Finland by truck and ferry, and prefabricated building elements were delivered for 400 km by 14 trucks. This long transport is the main energy consumer in module A4-5.

Primary energy consumption in module A and B6 is almost the same, even in a 50-year service life. This could be for two reasons. The first reason would be high energy performance of the building (see above), and the second would be the high ratio of biomass fuel in the energy mix of the CHP plant. As a result, more than half of the primary energy consumption in module B6 is renewable.

- F.8.5-9 Carbon footprint results
- F.8.5-10 Primary energy results
- F.8.5-11 Carbon footprint of different building elements
- F.8.5-12 Primary energy demand of different building elements

CARBON FOOTPRINT (A1-5, B6)
kgCO₂e

	<i>per m² of living area</i>	<i>per whole building</i>
Carbon footprint	1 000	548 151
Carbon storage	- 433	- 237 484
Net balance	567	310 667

Carbon footprint

The same trend could be seen as primary energy balance, approximately 50% of GHG emissions originate in the use stage (B6) and the other half in module A. The carbon storage capacity in wooden materials is almost the same as GHG emissions in module A1-5. As explained before, module A4 showed a larger carbon footprint than module A5 here as well.

Conclusions

The production stage of Joensuun Elli shows a similar result as the result of Mietraching. However, a totally different result can be seen in module B6. The actual energy demand for the building operation is also very similar, but a different energy mix for district heating and electricity makes a significant gap. GHG emission from the building operation becomes small when heat and electricity are provided from the CHP plant, and biomass fuel is used mainly in the plant. This comparison would indicate the importance of considering both the energy efficiency in a building life cycle and energy resources for carbon efficient wood construction.

PRIMARY ENERGY USE (A1-5, B6)
MJ

	<i>per m² of living area</i>	<i>per whole building</i>
Total	21 917	12 010 853
Renewable	8 730	4 784 339
Non-renewable	13 187	7 226 514
Energy content	- 4 151 38	- 2 274 958

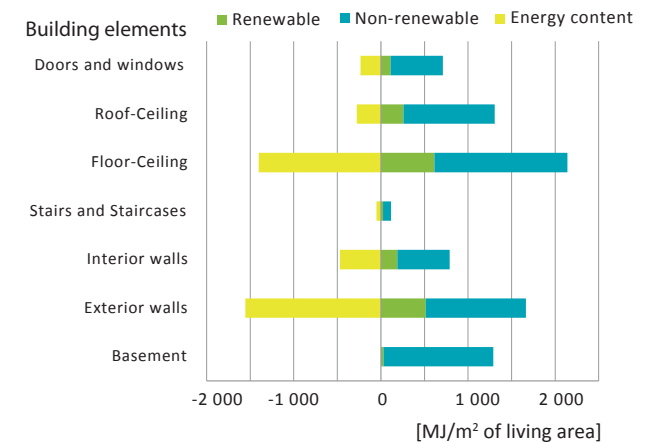
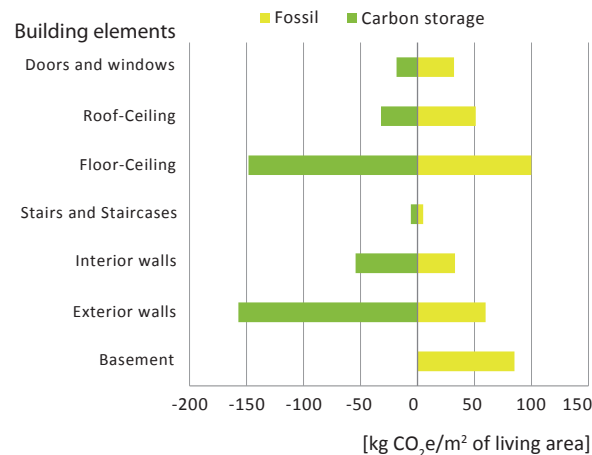

8.6

TERVAKUKKA PASSIVE HOUSE

Tampere, Finland, 2012

F.8.5-1



F.8.5-2

KEY FIGURES

Gross floor area	258	m ²
Net floor area	198	m ²
Living area	198	m ²
Gross volume	1 036	m ³
Net volume	567	m ³
Nr of occupants	4	persons
Planned service life	100	years

F.8.6-1 Exterior view of the house

F.8.6-2 Key figures of the building

F.8.6-3 Floor plans, 1:200

Client
Architect

Private
Kombi Arkkitehdit Oy
Matti Kuittinen, Julia Bilenko

Construction company

GreenBuild Oy

M. Kuittinen

The Tervakukka house is located in Tampere, in the middle Finland. It belongs to an area that was built for the annual housing fair 2012. This passive house was designed in cooperation with several stakeholders, with a common goal: to implement principles of “eco-functionality” in practice. The concept of eco-functionality has been developed in an earlier research project by the Work Efficiency Institute in Finland (TTS). It describes the interdependence of the functionality and environmental loads of a home.

The design team included experts in accessibility, ergonomics, building services, gardening and sustainability. The design work was steered by the client family and the Finnish Association for Nature Conservation (SLL).

The building is a single family home in a suburban district of Tampere, the third largest city in Finland. Its common areas are located downstairs, where also a spacious sauna department is built. The bedrooms and a home office are placed upstairs. A private balcony is placed between the main building and garage so that sunbaths can be taken without compromising privacy in the densely built neighbourhood.

All toilets and bathrooms are placed close to the technical space, in order to reduce the length of pipes. The building is heated with a hybrid solution that consists of electric floor

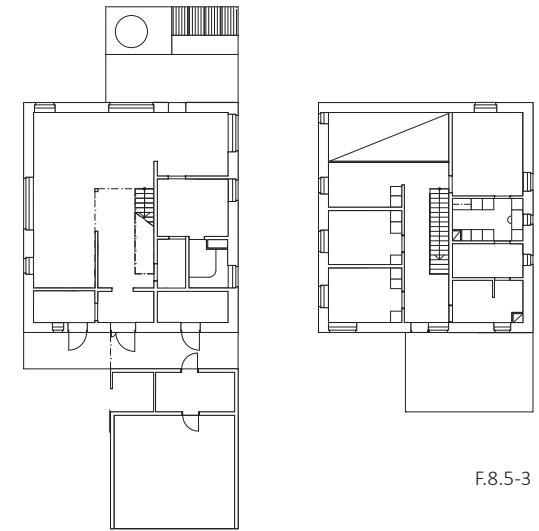

F.8.5-3

heating, electric air heating, wood heating (a fireplace), solar collectors and ventilation with an integrated heat pump and heat recovery. Summertime cooling is assisted with underground pipes, through which air is pre-cooled. Solar collectors were mounted on a southern wall, so that they would give energy during the winter months, when sun is very low. Wall-mounting also prevents them from being covered with snow. The family wanted to have a Jacuzzi but were concerned about its energy demand. As a solution, the water for a Jacuzzi is heated in a fireplace that has built-in heat transfer pipes.

The constructor of the house was GreenBuild, a Finnish company that makes wooden passive houses with recycled cellulose insulation.

Assessment

The aim was to study the greenhouse gas emissions and primary energy demand from the production phase (A1-3) and the operative energy use (B6) of a passive house. The energy content of wooden materials was also estimated (D). Furthermore, two alternative construction systems were compared: timber frame with cellulose insulation and aircrete block frame with EPS insulation. Both designs had the same U-values and energy efficiency.



The point of the assessment was the “as designed” stage, as accurate information from the construction site was not available.

Normative standards EN 15978 and ISO/TS 14067 were used as reference in the gathering and documentation of results.

The inventory was carried out from working drawings of the architect and structural engineer. The system boundary included the main structural elements and interior and exterior surfaces. An inventory for building services, white goods, furniture and gardening was not carried out, due to lack of data. The accuracy of the inventory includes used materials as designed and joinery with fixing materials as designed. Site energy use or waste was not assessed. Furthermore, temporary materials (for example, scaffolding and weather protection) and energy use for construction work or transportation were not assessed.

Operative energy use was estimated from the energy calculation of the building. There was a special use of green electricity for heating and operations. In Finland, a labelling scheme for green electricity has been developed by the Finnish Association for Nature Conservation. This “EKOenergy” scheme was approved to be expanded to other parts of Europe as well, after 23 nature conservation organisations from 18 countries agreed to support it. The label can be given to power companies that use only renewable energy and invest a certain share of income in building additional capacity for renewal energy. Therefore the greenhouse gas emissions from the use phase electricity are zero. This feature underlines the importance of controlling the emissions from the production phase.

An impact assessment was carried out by using GWP (global warming potential) and PE (primary energy) indicators from the selected database.

Data

The data source was ecoinvent version 2.2. The system boundary for data was cradle-to-gate (A1-3). EPDs (Environmental Product Declarations) could not be used, since they were not available for the majority of the used construction products. For consistency of data, we chose to use same the database for all products.

Structures and construction methods

The house was built on-site. Its structural system is balloon frame.

Foundation and floors

A slab-to-ground structure is used for the base floor. It is made from concrete and EPS insulation. The foundation is built with hollow EPS blocks (Soklex), which are filled with concrete cast on-site. Piling was required because of soft soil. In addition, a significant landfill of around 2 metres was required by city. All neighbouring site levels were equally raised, so that sewage pipe levels would better fit the areal collective sewage pipe level without pumping.

The intermediate floor was built on-site with wooden I-joists made of massive timber and HDF. The intermediate floor cavity was filled with cellulose insulation for sound insulation.

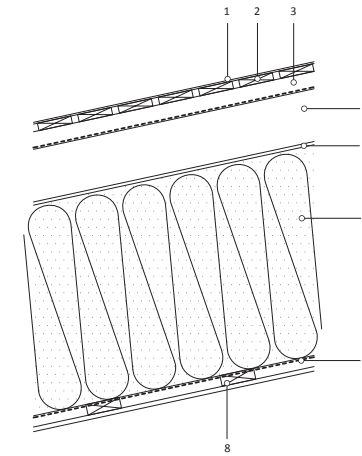

Roof

1. Metal roofing
2. Battens 22mm
3. Condensation barrier textile
4. Ventilation gap battens 120mm
5. Gypsum board
6. Roof trusses and cellulose insulation 600mm
7. Air barrier textile
8. Gypsum board

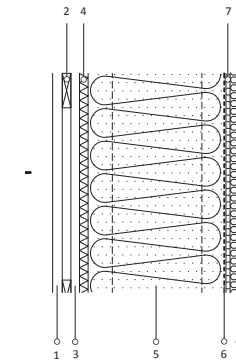

External wall (timber version)

1. Spruce cladding 28mm
2. Horizontal battens 25x100
3. Vertical battens 25x100
4. Wind barrier board LDF 25mm
5. Cellulose insulation 400mm >50kg/m³
6. Vapour barrier textile
7. Plywood

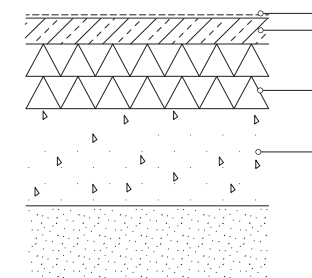

Base floor

1. Gravel 300mm
2. EPS insulation 200mm
3. Concrete slab 80 mm
4. Floor surface

- F.8.6-4 Roof detail
 F.8.6-5 Wall detail
 F.8.5-6 Base floor detail

External walls

The load-bearing wall studs are made from I-joists. Insulation is cellulose fibre that was wet-sprayed into wall cavities. An air-barrier layer is made from textile that is placed inside the insulation layer.

External cladding was built from spruce planks that were painted black with a traditional mixture of tar and linseed oil. Parts of cladding were realised from white cement fibre boards that had CNC-engraved ornaments on them.

Roof

The roof structure was made from nail trusses and supporting glulam and LVL beams. The shape of trusses was parallel to the roof. Cellulose insulation was sprayed into the cavities. Ventilation pipes could be left without insulation because they were placed in a warm area between the insulation layer and the lowered ceilings. The roof cover is painted steel. The colour of the roof was light grey because it reflects sunlight back into space and thus has a symbolic effect on global warming.

Other structural features

Internal walls were made from sawn massive wooden studs. Wooden panels and wallpaper with gypsum board were used for their cladding. Internal stairs were made of wood and safety glass. External terraces were built from impregnated wood.

Alternative design

The alternative design was based on aircrete blocks and EPS insulation. Only the external walls and intermediate floors were changed. The roof, base floor and foundation were the same in both designs.

External walls were made from internal gypsum board, 250mm aircrete blocks, 170mm EPS insulation and 30mm external rendering.

Intermediate floors were designed from reinforced aircrete slabs. Ceilings were rendered. Floors were comparable to the timber-framed design.

Construction work

The Tervakukka house was built on-site during the winter of 2011-2012. Weather conditions were humid because the autumn of 2011 was the warmest ever recorded in Finland. Extreme weather also caused accidents; a spruce tree fell over the half-finished building and parts of the partially finished wall structure had to be replaced.

Results

Primary energy demand

The aircrete version of the building had in total around a 30% higher primary energy demand for production of materials. This figure applies to the whole building. But for external walls and intermediate floors, the difference is considerably higher.

In the timber-framed version, most of the energy goes into the production of non-wooden materials for the foundation and the floor slab. In addition to concrete, the EPS insulation especially seems to be very energy intensive.

Carbon footprint

Only fossil greenhouse gas emissions were taken along in the impact assessment. In addition, carbon storage in wood products was included in the figures. Because the use electricity is carbon-neutral, the dominant part of the carbon footprint is caused by the production of building materials.

The aircrete version of the building had in total around a 40% higher carbon footprint as the timber-framed version. Again, if we look at external walls and intermediate floors, this difference was more dramatic.

ENERGY PERFORMANCE

F.8.6-7

Operative energy use	25 377 kWh/a
	128 kWh/m ² /a
Heat generation	Hybrid (electricity, solar, wood)
Heat distribution	Electric floor heating, air heating
Energy generation	Wood, solar
Air tightness	0,6 h ⁻¹
Energy class	Passive house

CARBON FOOTPRINT (A1-3)

F.8.6-8

kgCO₂e

	<i>per m² of living area</i>	<i>per whole building</i>
Carbon footprint	407,06	80 597,15
Carbon storage	-258,63	-51 209,72
Net balance	148,42	29 387,43

PRIMARY ENERGY USE (A1-3)

F.8.6-9

MJ

	<i>per m² of living area</i>	<i>per whole building</i>
Total	8 978,93	1 777 828,93
Renewable	766,23	151 712,81
Non-renewable	8 212,71	1 626 116,12
Energy content	-2 129,30	-421 601,63

In the timber-framed version, the emissions were slightly greater than the carbon storage within the selected system boundary. The dominant sources for carbon emissions were in the foundation and base floor, mainly because their EPS and concrete emissions were significant. Furthermore, the small areas of cement fibre cladding on the walls were significant when compared to other parts of the external wall. The main carbon storage was in the massive wooden parts, I-joists and wooden boards. The cellulose fibre insulation also acted as carbon storage.

Conclusions

This study shows that if material production and operative energy use are taken along, the timber-framed version of the passive house has a clearly lower carbon footprint and lower primary energy demand.

When analysing the emissions from the timber-framed passive house, the foundations and base floor are dominant. However, small design choices in claddings (such as cement fibre boards and gypsum boards) also seem to cause a fairly large share of emissions.

Especially when buildings have an environmentally sound energy supply – as carbon-neutral green electricity in this case – the role of construction materials seems to become very important. This further strengthens the

The case study demonstrated well that LCA or carbon footprinting with current normative requirements (e.g. EN 15978 or ISO/TS 14067) cannot be carried out in a reliable way from typical design documents of single family houses in Finland. Therefore more agile assessment norms should be developed, and the documentation from the design and construction phases should be improved.

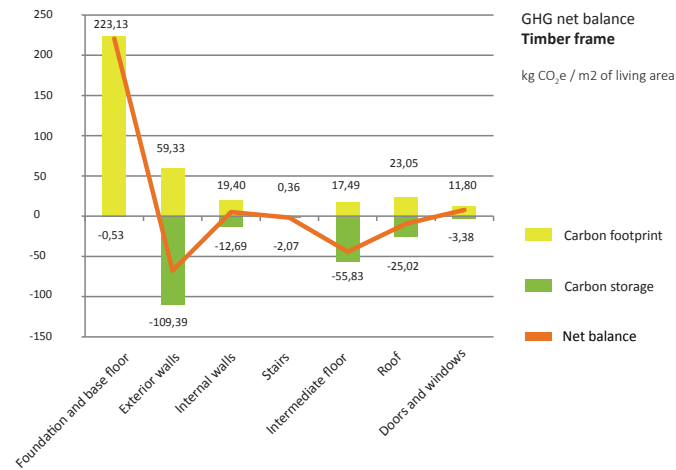

F.8.6-10 GHG emissions of timber frame design

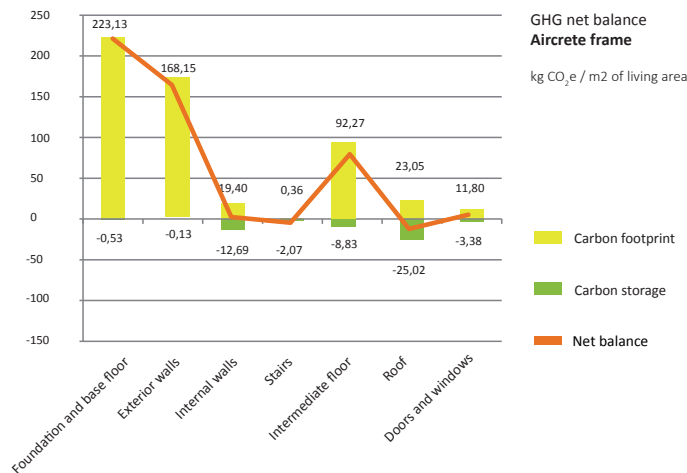

F.8.6-11 GHG emissions of aircrete frame design

Carbon footprint of exterior wall
kg CO₂e/m² of living area

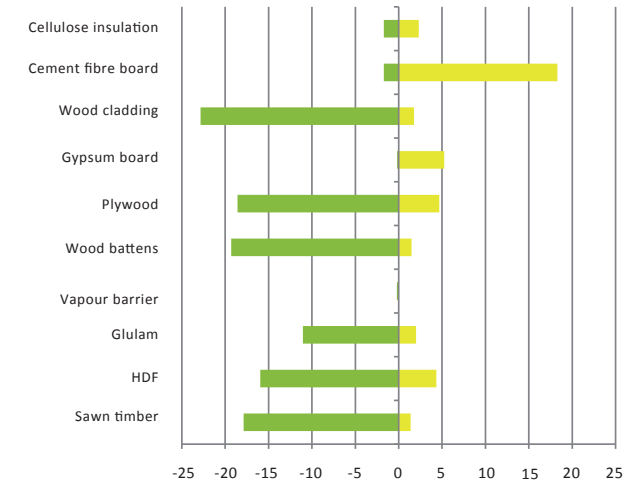

F.8.6-12 GHG emissions and carbon storage of timber external wall

Primary energy demand of exterior wall
MJ/m² of living area

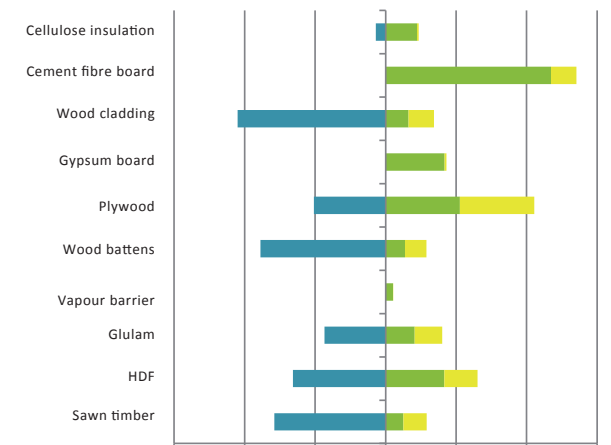

F.8.6-12 PE demand of timber external wall

8.7

PROGETTO C.A.S.E

L'Aquila, Italy

Client	Presidenza del Consiglio dei Ministri
Architect	Luigi Fragola & Partners
Structural engineers	Studio Legnopiù srl
HVAC design and building physics	Studio Associato Paci
Construction company	Consorzio Stabile Arcale



F.8.7-1
F.8.7-2

KEY FIGURES

Gross floor area	1 840	m ²
Net floor area	1 581	m ²
Living area	1 398	m ²
Gross volume	6 533	m ³
Net volume	4 796	m ³
Nr of occupants	78	persons
Planned service life	50	years

E. De Angelis, F. Pittau

Progetto C.A.S.E. is a complex of 185 multi-storey residential buildings built in L'Aquila (Italy) in 2009. The buildings were built in order to supply a temporary house to the population after the terrible earthquake which destroyed the city centre and nearby areas. Particularly, the building analysed is located in Cese di Preturo and consists of a three-storey residential building with 27 dwellings divided in seven different typologies. The living floor area is 1 398 m², while the net volume is 4 280 m³ with 2.8 m of net height between the floors.

The building is simple and regular with a compact volume. The plan is rectangular; the longer side is 48 m and the shorter side is 12 m. Internally, three wooden volumes contain both the stairs and the lifts. The orientation of the main façades is roughly north-south, while the east and west façades are completely blind. On the

contrary, the south façade – very regular and modular – has large windows that offer an optimal solar gain during the wintertime. The balconies are continuing along the side and separated each other by external partitions. On the other side, the north façade has smaller openings in order to minimize the heat losses and improve the thermal insulation during the wintertime.

The heating system is centralized with a gas heating unit under the basement floor. An insulated distribution system supplies hot water to the dwellings, in which fan coil units are provided on the floor.

Assessment

The assessment method is harmonized with the requirements of the new Standard EN 15978. Every single part of the building was taken into account: the foundation, basement, load-bearing timber structure, exterior and interior walls, floor slabs, doors, windows

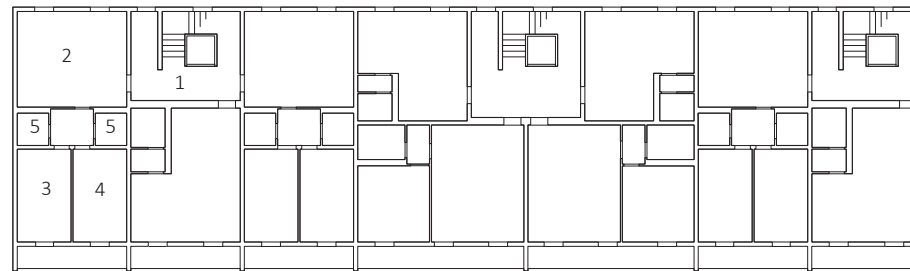

F.8.7-3

1. Corridor
2. Living room and kitchen
3. Bedroom
4. Bedroom
5. Bathrooms

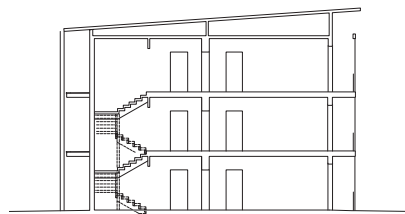

F.8.7-4

- F.8.7-1 The building in its environment
 F.8.7-2 Key figures of the building
 F.8.7-3 Ground floorplan, 1:200
 F.8.7-4 Section, 1:200



F.8.7-5

and roof. All the stages of the life cycle of the building were considered for the different building parts, while only the impacts due to the production of materials (mod. A1-3) were considered for the evaluation of the building services and installations. In the use and maintenance phase (mod. B), the total share of GHG emissions was estimated on the base of the related primary energy consumption for heating and the presumed yearly operational energy use. In addition, the GHG emissions for maintenance were estimated taken into account only the required energy for the substitution of the damaged elements at the end of the assumed reference service life. Finally, for the evaluation of the end-of-life phase (mod. C) a single scenario was considered, assuming that all the wooden parts were brought to incineration after their service life, while the non-wooden material was taken to landfill. No evaluation of the benefits beyond the system boundaries (mod. D) was carried out.

GHG emissions from bio-fuels were assumed as net-zero, considering that all the round wood needed came from environmentally managed forests. According to EN 16449, a rate of 50% of carbon per mass of dry wood was considered for the calculation of the carbon content in timber mass. Any consideration of future changes in energy mixes in the production of electricity and

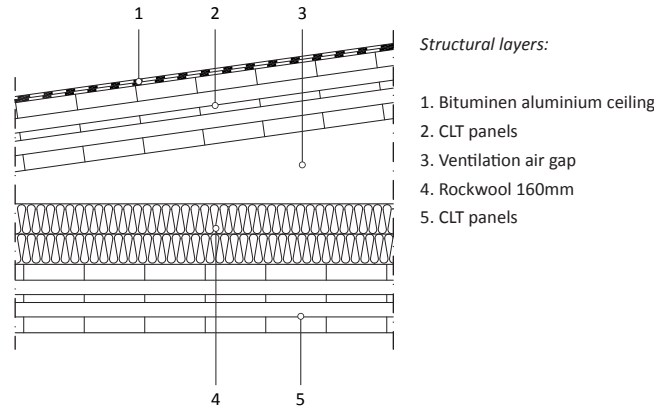

F.8.7-6

district heat was not assumed due to uncertainties in data and in future scenarios.

Data

Data from the ecoinvent 2.2 database was adopted in the LCIA of building materials, as well as for the carbon emission and energy consumption of transportation from gate to site (A4). The age of the data collected for each material and process is less than two years. No specific EPDs regarding the used materials in the building parts were available. For the evaluation of the energy content, the net calorific value was considered.

The quality of data for emissions from combustion of fuels is affected by the assumed mean efficiency of burning/incineration. The specific values of carbon emission per unit of primary energy provided were assumed per each fuel source, and the IPCC method considered for the calculation of CO₂e emissions. For the LCI of material, the actual Italian conditions were considered; in particular, the use of national average values for electricity, the distances for transport of products and the mean specific national emissions from electricity production in a power plant. No specific data of the waste management were available in the

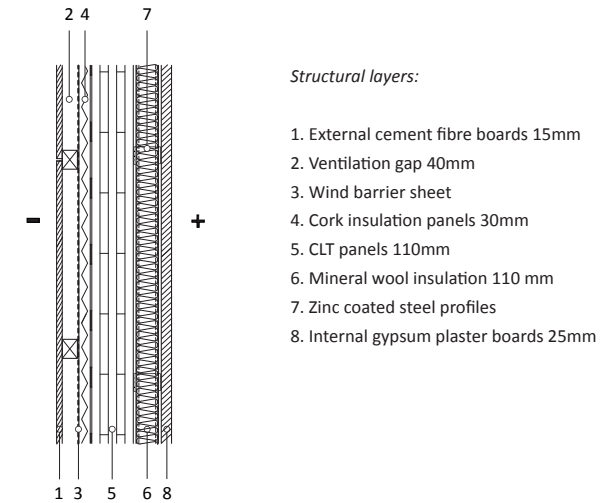

F.8.7-7

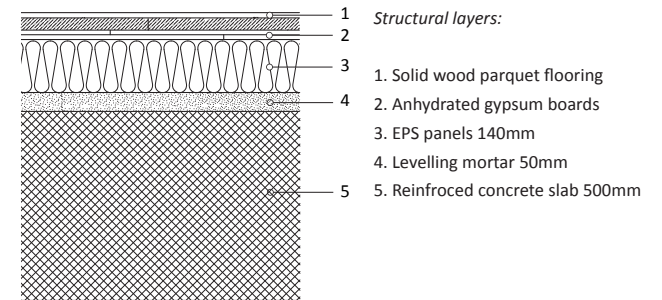

F.8.7-8

F.8.7-5 Facade detail of the building

F.8.7-6 Roof detail, 1:10

F.8.7-7 Wall detail, 1:10

F.8.7-8 Base floor detail, 1:10

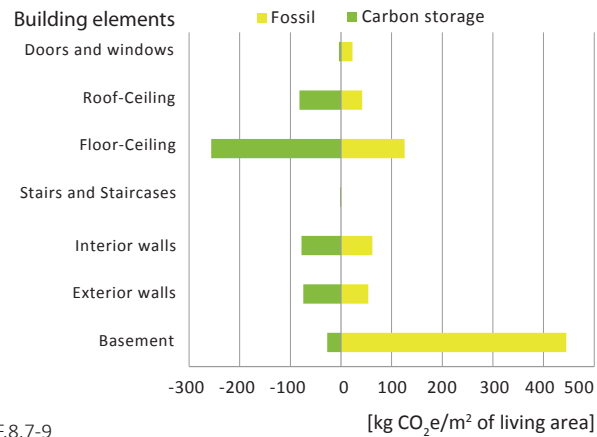

F.8.7-9

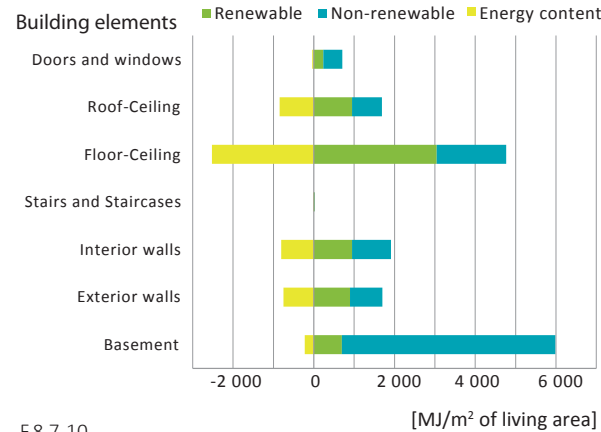

F.8.7-10

F.8.7-9 Fossil greenhouse gas emissions for the different building elements

F.8.7-10 Primary energy demand for the different building elements

on-site construction phase. For this reason, general data from the literature were taken into account.

The energy needs for heating were calculated through a steady-state simulation based on the Italian energy standard. The building is not monitored, therefore the real amount of primary energy consumed year by year is difficult to clearly estimate. For this reason, an average value of the annual energy consumption of a standard Italian family was considered for the evaluation of the operational energy and related carbon emission.

Structures and construction methods

The structure is completely made of CLT panels, except for the basement, which is made of concrete. Timber panels 11 cm thick were used for walls, while panels 18 cm thick were used for floors and the roof, which is ventilated and not insulated. A 16-cm insulation layer of fibre wood was placed in the upper floor, with a cross ventilation which ensures the best hygrothermal conditions during the summer.

Foundation and floors

The foundation is completely made of concrete, with a slab 50 cm thick on the ground and an upper basement 50 cm thick, insulated with 14 cm of EPS. The basement is supported by reinforced concrete columns 80x80 cm.

The internal floors are made of 18 cm CLT panels, with 4 cm mineral wool, a double layer of gypsum fibreboards, 3 cm chipboard and wooden flooring. The upper floor is insulated with 16 cm fibre wood.

External walls

The external walls consist of an internal part in a metallic light structure, insulated with 5 cm mineral wool, on which the plasterboard is fixed. On the other side, a continuous insulation layer of cork is fixed with glue on CLT panels. The external cladding is made of grey cement fibreboard fixed on spruce battens, which create a ventilated air gap.

Roof

The sloping roof is made of two layers: the structural part in CLT panels and the waterproof sheet.

Other structural features

Special seismic isolators (metallic sliding pendulum isolators) are placed between each concrete column and the basement in order to guarantee the proper seismic insulation of the timber structure from the ground.

Construction work

After the realization of the concrete basement, the building was mainly assembled on-site. In a few days, the timber structure was built up and in less than 3 months all the components were rapidly assembled.

Prefabrication

The prefabrication level of the structure is not very high. Overall, the process consisted of cutting and drilling the CLT panels, as well as in fixing the metallic connections to the different supports. All the other parts of the building (insulation, claddings, windows, service installations, etc.) were installed on-site, except for the bath cells, which were fully prefabricated and assembled on-site.

ENERGY PERFORMANCE

F.8.7-11

Operative energy use	60 141 kWh/a 43,01 kWh/m ² /a
Heat generation	Gas condensing boiler
Heat distribution	Fan coil units
Air tightness	0,4 h ⁻¹
Energy class	B (Italian Energy Standard)

On-site work

Most of the activities during the construction phase were made on-site. The duration of the work was relatively short – only 72 days. In order to respect the constrained timing, the contractors were forced to work all day long, night included, with a relevant consumption of electricity for lighting.

Results

Primary energy balance

From the calculation over the whole building life cycle, the most relevant impact in terms of PE-nr is given by module B (use & maintenance), with a share of 42%. Following the A1-3 (production phase) accounts for a share of 39%, with a marginal share given by modules A4-5 (construction) and C (end of life). On the contrary, if the PE-r is considered, the most relevant impact is given by mod. A1-3 (86%). A marginal share is accounted by module B (12%) module C (1,3%) and finally by module A4-5 (0,7%). The building elements contribute to the overall energy consumption with a share of 80-85%. More than 60% of the PE-nr consumed is given by the basement.

CARBON FOOTPRINT (full life cycle)

F.8.7-12

kgCO₂e

	<i>per m² of living area</i>	<i>per whole building</i>
Carbon footprint	2 271	3 175 135
Carbon storage	- 580	- 811 492
Net balance	1 691	2 363 643

Carbon footprint

Module B is responsible for the most fossil carbon emissions, with a share of 49%, followed by module A1-3 (35%) and a marginal share by modules A3-5 and C. Considering the biogenic carbon emissions instead, module C is the most relevant, with a share of 62%, followed by module A1-3 (27%), module B (7%) and finally module A4-5 (5%). The building elements are responsible for the most relevant GHG emissions, with a share of 81-84%. More than half of that impact is given by the basement.

Conclusions

On the base of the achieved results, some basic conclusions can be summarized here:

- The use phase plays a fundamental role in building the carbon footprint. The relative low thermal resistance of the envelope, if compared to the high performance of very low energy buildings, leads to a high score of fossil carbon emission for heating, which affects the results significantly. Maintenance has a modest dominance, affecting the results for a share of roughly 5%.

PRIMARY ENERGY USE (full life cycle)

F.8.7-13

MJ

	<i>per m² of living area</i>	<i>per whole building</i>
Total	36 441	50 945 059
Renewable	8 216	11 485 892
Non-renewable	28 225	39 459 167
Energy content	- 5 781	- 8 082

F.8.7-11 Energy performance of L'Aquila building

F.8.7-12 Carbon footprint results for the full life cycle

F.8.7-13 Primary energy use results for the full life cycle

- The carbon emission given by building services and installations (heating machinery, water pipes, electricity, etc.) is very difficult to estimate. If specific EPDs are not available, only the relative share of GHG emissions due to the production of materials can be taken into account. However, the results show that their contribution is modest, roughly 1-2%.
- In the production and construction phase, a relevant share of GHG emissions and PE consumption is due to the realization of the foundations and basement. In order to ensure a more sustainable building environment, the influence of these parts, often almost completely ignored by architects and operators in the building sector, should be seriously considered during the design phase.

8.8

Lessons learned

Energy recovery from wooden residues can be a remarkable benefit for choosing wood for construction material.

Wood-framed passive houses with energy-efficient heat supply **reduce climate impacts**. Generally, massive wood construction systems result in the largest amounts of residues and bio-energy potential.

Site works and foundations seem to have a high impact on the carbon footprint and primary energy demand. Especially the use of concrete, re-bars and hard insulation boards cause emissions.

Emissions from construction work and transportation are very case-specific. The energy demand from construction work can vary highly depending on the outside temperature, because heating a half-finished building or pre-fabrication facilities seems to be very energy-consuming.

There will be a **shift in the lifecycle carbon efficiency** of buildings from the use phase to the production phase. This is because buildings require less energy for their operation.

Including all **building service installations** with their ancillary materials may be very time-consuming and include large uncertainties. Therefore it could be considered that building service information is left out of an assessment until it becomes better documented in the construction phase.

The design phase does not typically give enough information for the carbon footprint or primary energy assessment that is required in standards (e.g. EN 15978). Therefore a **more agile assessment scheme** for enabling assessment in design phase would be needed.

F.8.8-1

Covered parts of life cycle

Product stage

A1	Raw material supply
A2	Transport
A3	Manufacturing

Construction process

A4	Transport
A5	Construction process

Use stage

B1	Use
B2	Maintenance
B3	Repair
B4	Replacement
B5	Refurbishment
B6	Operational energy use
B7	Operational water use

End-of-life stage

C1	Deconstruction
C2	Transport
C3	Waste processing for reuse, recovery and recycling
C4	Disposal
D	Additional loads and benefits beyond the system boundary

- Included
- Included in part
- Not included

F.8.8-1 Covered parts of life cycle

F.8.8-2 Covered parts of building

8.2 Wälludden as a case study of three new wood building systems

BBR (Boverkets Byggregler). 2012. Boverkets Författningssamling (Building and Planning Regulations). The National Board of Housing, Building and Planning, Karlskrona, Sweden. (In Swedish).

Björklund T. and Tillman A-M., 1997. LCA of building frame structures: environmental impact over the life cycle of wooden and concrete frames. Technical Environmental Planning Report 1997:2. Chalmers University of Technology.

Dodoo, A., Gustavsson, L. and Sathre, R., 2009. Carbon implications for end-of-life management of building materials. Resources, Conservation and Recycling, 53(5): 276-286.

FEBY (Forum for Energieeffektiva Byggnader), 2009. Kravspecification för passivhus, 2009. (In Swedish).

Gustavsson, L. and Karlsson Å., 2002. A system perspective on the heating of detached houses. Energy Policy, 30(7): 553-574.

Gustavsson, L., Joelsson, A., and Sathre, R. 2010. Life cycle primary energy use and carbon emission of an eight-story wood-framed apartment building. Energy and Buildings, 42(2): 230-242.

Gustavsson, L., Dodoo, A., Truong, N.L., and Danielski, I. 2011. Primary energy implications of end-use energy efficiency measures in district heated buildings. Energy and Buildings, 43 (1): 38-48

Gustavsson, L., Pingoud, K., and Sathre, R., 2006. CO2 balance of wood substitution: comparing concrete- and wood-framed buildings. Mitigation and Adaptation Strategies for Global Change, 11(3): 667-691.

Gustavsson L. and Sathre R., 2006. Variability in energy and CO₂ balances of wood and concrete building materials. Building and Environment, 41(7): 940-951.

Karlsson Å., 2003. ENSYST, Lund: Lund University, Sweden.

Strusoft. 2010. Overview of VIP-Energy. Accessed at www.strusoft.com on June 13, 2011.

8.3 4 Holz Mietraching

AGFW Branchenreport 2006, by the German Heat and Power Association -AGFW- (in German).

8.4 Austrian buildings

Amtmann, M.; Gross, M., 2011. Austrian Building Typology—Eine Typologie österreichischer Wohngebäude. German publication only: URL: <http://www.building-typology.eu/>.

Ecoinvent Data v2.1. The Life Cycle Inventory Data version 1.1. Hg.v. Swiss Centre for Life Cycle Inventories, Dübendorf, 2009.

ECOSOFT 3.4.2: Software for the ecological assessment of building components and buildings. <http://www.ibo.at/de/ecosoft.htm> (2012-11-21, actual version: ECOSOFT 5.0, including IBO-database 2012)

IBO-Referenzdatenbank, 2009. Wesentliche methodische Annahmen. Boogman Philipp, Mötzl Hildegund. Version 2.2, Stand 9.10.2009, German publication only: URL: http://www.ibo.at/documents/LCA_Methode_Referenzdaten_kurz.pdf.

Takano, A., 2011. Standards for quantity calculation of building components. Background material for €CO₂ project.

8.5 Joensuun Elli

Energiategollisuus. 2013. <http://energia.fi>

Fortum. 2013. <http://www.fortum.com>



9. Summary and conclusions

9 SUMMARY AND CONCLUSIONS



M. Kuittinen, A. Ludvig, G. Weiss

Statements such as “wood is an environmentally friendly material” or “wooden houses can function as carbon storage sites” are often made but rarely backed up with scientific proof. The chapters of this book fill in some knowledge gaps by applying advanced methods for determining the carbon footprint of wooden buildings during their full life cycles. This goes under the condition that forests are managed so as to maintain or increase forest carbon stocks.

For this purpose, Chapter 2 (“Background”) discusses two Life Cycle Analysis (LCA) approaches, namely attributional and consequential LCA, and describes the environmental policies, norms and standards that are currently framing environmental assessments of the building sector.

There are several necessary parts and phases that must be included in an LCA of buildings. Therefore, Chapter 3 (“Fundamentals”) presents definitions for the functional units, evaluation indicators and system boundaries with respect to time, place and activities. LCA involves material and energy flows within and between different economic sectors, including forestry, manufacturing, construction, energy and waste management.

At the building level, Chapter 4 (“Carbon footprint calculation methodology”) introduces in detail the information that is required for a practical assessment of the environmental impact of whole buildings, such as the quantities and qualities of building materials, the environmental impacts of products, the energy demand of the building and the characteristics of energy supply systems. The service life of building components and elements also need to be taken into account based on the particular situation (such as the building location, the climatic area, the weather conditions at the site, orientation and detailing). Calculations of wood-based building systems are rather complex and sometimes practical simplifications may be required. The chapter therefore suggests a simple but accurate system approach as the best starting point.

In order to better understand the sustainable origin of wood products, Chapter 5 (“Environmental aspects of raw material supply and manufacturing”) complements these findings with a discussion of the life-cycle aspects of a building at the wood product level. Information on individual products is typically compared when designing, planning and building a house. Here the assessment considers the extraction of raw materials and the transportation and manufacturing stages of the products; it also discusses the impacts of different factors on the carbon footprint of sawn timber. It suggests improvements for new eco-efficient

solutions, such as the need to understand the environmental impact from different ways of drying timber and also variations in saw mill-specific results.

Building on the fundamentals of system boundaries for practical LCAs of whole buildings presented in Chapter 4, Chapter 6 (“Good practices for carbon efficient wood construction”) demonstrates applied good practices for carbon-efficient wood constructions. It outlines the design phase for low-carbon wooden houses and evaluates the influence of the construction phase as well as different modes of production (on-site versus off-site production). Furthermore, it demonstrates the impact of transportation, of use and of maintenance as well as the impact of end-of-life deconstruction, waste management and recycling.

Chapter 7 (“Service life and moisture safety”) explains the interdependency of good moisture safety and the building’s carbon footprint. An optimal service life is necessary in order to minimize the carbon footprint of the full life cycle of a building. Heat, moisture and air are interrelated and influence the service life of wooden buildings, and therefore, they have to be considered as early as the planning phase. The chapter shows how moisture control and the indoor environment should be assessed and

predicted, and it outlines five factors that must be considered for wooden buildings.

In Chapter 8, we calculate the energy efficiency and carbon efficiency for eight wood-framed buildings from different European regions, namely from Austria, Finland, Germany, Italy and Sweden. Using real buildings as an example, this chapter shows how the use of wood affects the carbon footprint and primary energy demand of buildings.

Overall, our findings indicate that there are convincing advantages and potentials for using wood in construction to mitigate climate change. However, the current normative policy framework in these emerging matters is still under development. The scientifically proven methods and measures for assessing the benefits of wood are extensively outlined and discussed in this book. The life cycles of buildings involve a number of material and energy flows in different phases of the construction process. Important parts include forestry, transportation, manufacturing, construction, energy use, waste management and recycling.

A carbon footprint analysis of wooden buildings is more complex than that of many other products due to the dynamics of forest growth and the variety of co-products involved. For assessments focusing on individual buildings, this book suggests practical analytical simplifications. It also outlines the changes that can result from applying different building designs. The system boundaries and principles used for calculating the environmental impact of buildings can significantly influence the assessment results; therefore, clear descriptions of all assessment assumptions and results are fundamental requirements when making all calculations.

Findings

From our findings, we can offer a number of insights about the use of wood in carbon-efficient construction.

Life cycle analysis

- Full life cycle and energy chains for buildings should be considered with broad enough system boundaries so that all significant parts are included.
- Simplified system boundaries are proposed for practical calculations of the direct environmental effects resulting from buildings.
- Geographical and country-specific differences have significant effects on the carbon footprint of wood-based products. Climatic differences have an impact on forest species and management methods, and country-specific energy mixes have an impact on CO₂ emissions.
- The book demonstrates that country-specific data should be made available and that the results should be presented separately for different ways of calculating environmental impacts.

Energy and material resources

- There should be an optimal use of renewable energy sources during all phases of production as well as for the use phase and the end-of-life stage.
- Long-term and resource-efficient use of wood with engineered premium qualities, such as plywood, laminated wood and timber frame construction, are necessary for ensuring sustainable construction with wood.
- The construction phase itself seems to have only a minor environmental impact in comparison to the material side and the building's operations. Here, the transportation of building components and prefabricated building elements has a relevant

impact. Prefabrication (off-site construction) seems to be more environmentally friendly compared to on-site work. Prefabrication (off-site construction) seems to be a more environmental way of construction compared to on-site work.

Maintenance, recycling and end-of-life

- Maintenance and material renovation significantly affect the durability of wooden buildings. The moisture safety measures listed in this book need to already be considered during the design phase in order to guarantee an appropriate service life. These measures need particular attention in highly insulated buildings.
- During the planning and design phase, the eventual deconstruction, reuse and recycling of all products should be considered for improving the resource-efficiency of the building sector.
- In cases where material reuse is not practical, burning with energy recovery may have significant energy and climate benefits since the use of other energy resources, such as fossil energy, can be reduced.

Standards

- Current standards that are related to the environmental assessment of buildings (e.g. EN 15978) set good common rules, but are not practical enough to be applied during the design phase of buildings, and thus they can hardly be used in support of early decision making. New agile standards are required for iterative decision making during the design and construction process.

Due to progressive technical developments, buildings might require less and less operating energy in the future. Thus, the importance of life-cycle calculations for the production phase will increase. This is why efforts for reducing a building's carbon footprint and increasing its energy efficiency will become even more important during the production and construction phases of a building project. The present book is one step in this direction.



10. Appendices

AUTHORS

Arvidsson, Jesper, Professor, Division of Building Physics, Lund University. Main working areas: Heat and Mass Transfer and Moisture Safety in Buildings.

E-mail: jesper.arvidsson@byggtek.lth.se

De Angelis, Enrico, Associate Professor, Civil Engineer and Head of the PhD Program in Architecture, Built Environment and Construction Engineering, Politecnico di Milano. Main working areas: Building Performance Engineering, Building Pathology and Design Review. E-mail: enrico.deangelis@polimi.it

Dodoo, Ambrose, Senior Lecturer, Sustainable Built Environment Research Group at Linnaeus University. Main working areas: Life Cycle Analysis, Carbon Footprint Analysis; Energy Simulation of Buildings, Primary Energy and Environmental Analysis of Building Systems. E-mail: ambrose.dodoo@lnu.se

Dolezal, Franz, Senior Researcher, Holzforschung Austria (HFA). Main working areas: Building Physics, Building Acoustics, Sustainability of Wooden Materials and Buildings. E-mail: f.dolezal@holzforschung.at

Gustavsson, Leif, Professor of Building Technology, The Sustainable Built Environment Research Group, Linnaeus University. Main working areas: Systems Analysis from a Bottom-up Perspective Linked to Sustainable Development, Building Construction, Energy Efficiency, Renewable Energy, Forestry and the Interaction Between These Fields. E-mail: leif.gustavsson@lnu.se

Hafner, Annette, Senior Researcher (Architect), Chair of Timber Structures and Building Construction, Technische Universität München. Main working areas: Life Cycle Assessment, Sustainability Assessment of Buildings, Quality Assurance.

E-mail: a.hafner@tum.de

Häkkinen, Tarja, Senior Principal Scientist, Technical Research Centre of Finland (VTT). Main working areas: Sustainable building, Environmental Assessment, Life Cycle Management, Development of Assessment Methods and Indicators for the Built Environment. E-mail: tarja.hakkinen@vtt.fi

Kuittinen, Matti, Research Manager, Architect (M.Sc.), Aalto University, School of Arts, Design and Architecture, Department of Architecture. Main working areas: Wood Construction, Ecological Architecture, Environmental Policies, Humanitarian Aid.

E-mail: matti.kuittinen@aalto.fi

Linkosalmi, Lauri, Doctoral Candidate, (M.Sc.), Aalto University, School of Chemical Technology, Department of Forest Product Technology. Main working areas: Wood-based Materials, Life Cycle Assessment, Carbon Footprint of Wood Products.

E-mail: lauri.linkosalmi@aalto.fi

Ludvig, Alice, Senior Researcher, European Forest Institute Central-East European Regional Office (EFICEEC) c/o Institute of Forest, Environmental and Natural Resource Policy, University of Natural Resources and Life Sciences, Vienna (BOKU). Main working areas: Political Systems, Political Science, Policy Analysis, Qualitative Methods in Empirical Social Science Research.

E-mail: alice.ludvig@boku.ac.at

Mair am Tinkhof, Oskar, Scientific Officer, Austrian Energy Agency (AEA). Main working areas: Energy Demand of Buildings and Households, Industry and Commerce.

E-mail: oskar.mair@energyagency.at

Mötzl, Hildegund, Head of IBO Research & Development, Austrian Institute for Building and Ecology GmbH (IBO). Main working areas: Life Cycle Assessment of Buildings, Building Products, Building Physics, Indoor Air, Development of Assessment Tools, Sustainable Buildings and Urban Areas. E-mail: hildegund.moetzl@ibo.at

Mundt-Petersen, S. Olof, Doctoral Candidate, (M.Sc.), Division of Building Physics, Lund University, Lund. Main working areas: Energy Need, Moisture Safety and Heat and Moisture Transport in Buildings. E-mail: solof.mundt_petersen@byggtek.lth.se

Ott, Stephan, Senior Researcher (Architect), Chair of Timber Structures and Building Construction, Technische Universität München. Main working areas: Life Cycle Assessment, Energy Efficiency, Refurbishment of Buildings. E-Mail: ott@tum.de

Peñaloza, Diego, Doctoral Candidate, Swedish Technical Research Institute (SP), Wood Technology Unit. Main working areas: Sustainability Assessment of Wood Construction and Bio-based Materials, Analysis of the Role of Bio-based Materials in the Sustainability of the Construction Sector.

E-mail: Diego.Penaloz@sp.se

Pittau, Francesco, Project Researcher, ABC Department, Architecture, Built Environment and Construction Engineering, Politecnico di Milano, Milano. Main working areas: Wood Constructions, Technological Design, Building Energy Efficiency, Life Cycle Assessment. E-mail: francesco.pittau@polimi.it

Sathre, Roger, Senior Researcher, Sustainable Built Environment Research Group at Linnaeus University. Main working areas: Life Cycle Environmental Analysis of Energy, Industrial, and Forestry Systems. E-mail: roger.sathre@lnu.se

Spitzbart, Christina, Researcher, Holzforschung Austria (HFA). Main working areas: Sustainability of Wooden Constructions, Energy Performance of Buildings. E-mail: c.spitzbart@holzforschung.at

Takano, Atsushi, Project Researcher, School of Chemical Technology, Department of Forest Products Technology, Aalto University, Helsinki. Main working areas: Wood Architecture, Sustainable Building Design, Vernacular Building. E-mail: atsushi.takano@aalto.fi

Toratti, Tomi, Senior Advisor, Wood Construction, Finnish Confederation of Construction Industries (RTT), Helsinki. Main working areas: Timber Construction, Timber Building Products, Structural Engineering, Building Physics, Standardisation.

E-mail tomi.toratti@rakennusteollisuus.fi

Valtonen, Tuovi, Research Scientist, Stora Enso Oyj, Research Centre Imatra, Finland. Main working area: Product and Process Sustainability Assessments. E-mail: tuovi.valtonen@storaenso.com

Vares, Sirje, Senior Research Scientist, Technical Research Centre of Finland (VTT). Main working areas: Environmental Assessment of Building Products and Buildings, Life Cycle Assessment Methods, Assessment Tools, Information Management of Building Products. Design and Development of Such Tools For Products and Buildings and Service Life Prediction of Building Parts Exposed to Weather.

E-mail: sirje.vares@vtt.fi

Weiss, Gerhard, Work Area Leader, European Forest Institute Central-East European Regional Office (EFICEEC) c/o Institute of Forest, Environmental and Natural Resource Policy, University of Natural Resources and Life Sciences, Vienna (BOKU). Main working areas: Innovation and Entrepreneurship, Forest and Forest Sector Policy. E-mail: gerhard.weiss@boku.ac.at

Winter, Stefan, Professor of Timber Structures and Building Construction, Technische Universität München (TUM) and FiDiPro Professor, Aalto University, Department of Forest Products Technology. Main working areas: Energy Efficiency and Ecological Building Construction, Prefabricated Timber Structures, Timber Engineering and Fire Protection, MPA Bau TUM (Material Testing Lab). E-Mail: winter@tum.de

Zanata, Giulia, Research Assistant, ABC Department, Architecture, Built Environment and Construction Engineering, Politecnico di Milano, Milano. Main working areas: Architecture, Construction Management, Life Cycle Assessment, Life Cycle Cost.

E-mail: giulia.zanata@mail.polimi.it

ABBREVIATIONS

ALCA	Attributional LCA	IEA	International Energy Agency
BAT	Best Available Technologies	ILCD	International Reference Life Cycle Data System
BIM	Building Information Model	IPCC	Intergovernmental Panel on Climate Change
BNB	Assessment System for Sustainable Building	ISO	International Organization for Standardization
BREEAM	BRE Environmental Assessment Method	JRC	Joint Research Centre
CEN	European Committee for Standardization	KVH	Finger-jointed Solid Construction Timber
CF, CFP	Carbon Footprint	LCA	Life Cycle Assessment
CHP	Combined Heat and Power	LCI	Life Cycle Inventory
CLCA	Consequential LCA	LEED	Leadership in Energy and Environmental Design
CLT	Cross Laminated Timber	MER	Material Energetic Recovery
CRU	Component Recycling Use	MFR	Material For Recycling
DG	Directorate General	nZEB	Nearly Zero-Energy Building
DG CLIM	Directorate General for Climate Action	PCR	Product Category Rules
DG ENTR	Directorate General Enterprise and Industry	PE	Primary Energy
DGNB	German Sustainable Building Council	PEF	Product Environmental Footprint
EFTA	European Free Trade Association	PEFC	Programme for the Endorsement of Forest Certification
ELCD	European Reference Life Cycle Database	PV	Photovoltaic
EPBD	Energy Performance of Buildings Directive	R&D	Research and Development
EPD	Environmental Product Declaration	RH	Relative Humidity
ESL	Estimated Service Life	RSL	Reference Service Life
ETICS	External Thermal Insulating Composite Systems	SB	Sustainable Building
FSC	Forest Stewardship Council	SCC	Standing Committee on Construction
GHG	Greenhouse Gases	SM	Secondary Material
GPL	Liquefied Petroleum Gas	TAB	Technical Assessment Bodies
GPP	Green Public Procurement	TC	Technical Committee
GWP	Global Warming Potential	UCTE	Union for the Coordination of Transmission of Electricity
HQE	High Quality Environmental standard		
HVAC	Heating, Ventilation, and Air-Conditioning		

PICTURE CREDITS

COVER Åke E:son Lindman

CHAPTER 1

F.1.1 Jussi Tiainen
F.1.2 Åke E:son Lindman
F.1.3 Åke E:son Lindman

CHAPTER 2

F.2.0 Pitopia/ Alex Loban
F.2.1 Caroline Moinel
F.2.2 Caroline Moinel
F.2.3 Huber&Sohn GmbH&Co.KG
F.2.5 Åke E:son Lindman
F.2.6 Stora Enso
F.2.7 Åke E:son Lindman
F.2.9 Mikko Auerniitty
F.2.10 Jussi Tiainen
F.2.11 Pekka Koli
F.2.12 Åke E:son Lindman

CHAPTER 3

F.3.0 Mikko Auerniitty
F.3.3 Caroline Moinel
F.3.6 Åke E:son Lindman
F.3.7 Mikko Auerniitty

CHAPTER 4

F.4.0 Stora Enso
F.4.1-2 Åke E:son Lindman
F.4.1-3 Åke E:son Lindman

F.4.4-1 Åke E:son Lindman
F.4.5-3 Åke E:son Lindman
F.4.5-5 Svenskt Trä
F.4.5-5 LTH
F.4.5-5 Jussi Tiainen
F.4.5-10 Puuinfo
F.4.5 Åke E:son Lindman

CHAPTER 5

F.5.0 Pitopia/Otto Feis
F.5.2-3 Pitopia/ Anne Katrin Figge
F.5.2-4 Svenskt Trä
F.5.3-1 Pitopia/Heiko Römpf
F.5.5-1 Svenskt Trä

CHAPTER 6

F.6.0 Stora Enso
F.6.1-2 Dörthe Hagenguth
F.6.1-3 Stora Enso
F.6.3-13 Paolo Lavischi
F.6.4-1 Åke E:son Lindman
F.6.5-2 Kimmo Räisänen
F.6.5-3 Juhani Fräk
F.6.6 Paolo Lavischi
F.6.7 Åke E:son Lindman

CHAPTER 7

F.7.0 Aalto University Wood Program
F.7.1 LTH

F.7.3 Sp Trä
F.7.4 LTH
F.7.5 LTH
F.7.6 Åke E:son Lindman
F.7.11 Aalto University Wood Program

CHAPTER 8

F.8.2-1 Svenskt Trä
F.8.3-1 Huber&Sohn GmbH&Co.KG
F.8.3-9 Huber&Sohn GmbH&Co.KG
F.8.4-1 HFA
F.8.4-6 Glorit Bausysteme GmbH
F.8.4-12 Ing. Graf Zimmerei und Holzbau GmbH
F.8.5-1 Stora Enso
F.8.5-5 Stora Enso
F.8.6-1 Ari Ijäs
F.8.6-5 Jussi Koivunen
F.8.7-1 Paolo Lavischi
F.8.7-5 Paolo Lavischi
F.8.9 Dörthe Hagenguth

CHAPTER 9

F.9.1 Jussi Tiainen
F.9.2 Åke E:son Lindman



WOOD IN CARBON EFFICIENT CONSTRUCTION

WOOD IN CARBON EFFICIENT CONSTRUCTION

Tools, methods and applications

Wood is a renewable material that stores carbon from the atmosphere in it. But how carbon efficient are wooden buildings, when their full life cycle is taken into account?

This topic is discussed from the following viewpoints:

- Greenhouse gas and primary energy balances of wooden buildings.
- Carbon footprint calculation methodology.
- Environmental aspects of raw material supply and manufacturing.
- Good practices for designing and building carbon efficient wooden buildings.
- Examples of how optimal service life can be reached with proper moisture safety.
- Case studies from 8 different wooden buildings that exemplify, in detail, the accumulation of emissions and storage of carbon.
- Overview of standardisation and environmental policies that are linked to the carbon footprint of buildings.

This book is a result of a European research project that focused on various aspects of the life cycle of wooden buildings. It was carried out by 44 scientists and practitioners from 19 different organisations.

ISBN 978-9-0820-9080-2



9 789082 090802 >

