

A Multilayered Space-Event Model for Navigation in Indoor Spaces

Becker, T., Nagel, C., Kolbe, T. H.

{becker, nagel, kolbe}@igg.tu-berlin.de
Institute for Geodesy and Geoinformation Science
Technische Universität Berlin
Strasse des 17. Juni, 10623 Berlin
Germany

Abstract

In this paper a new conceptual framework for indoor navigation is proposed. While route planning requires models which reflect the internal structure of a building, localization techniques require complementary models reflecting the characteristics of sensors and transmitters. Since the partitioning of building space differs in both cases, a conceptual separation of different space models into a multilayer representation is proposed. Concrete space models for topographic space and sensor space are introduced. Both are systematically subdivided into primal and dual space on the one hand and (Euclidean) geometry and topology on the other hand. While topographic space describes 3D models of buildings and their semantically subdivisions into storey's and rooms, sensor space describes the positions and ranges of transmitters and sensors like Wi-Fi access points or RFID sensors. It is shown how the connection of the different layers of the space models describe a joint state of a moving subject or object and reduces uncertainty about its current position.

1. Introduction

Over the last decade, personal navigation systems (PNS) became an established tool for route planning and guidance of individual traffic using cars

and other vehicles. From the technical aspect this was made possible mainly due to the availability of global localization techniques like GPS on the one side and the acquisition and provision of the road network for large parts of the world on the other side.

Pedestrian navigation systems are not as successful as car navigation systems yet. The crucial point is that pedestrians can freely move inside and outside of buildings, but satellite localization still only works outdoor and information about navigation space is only available for the outdoor environment so far. However, indoor navigation would be helpful for finding locations like shops, police, rest rooms, or (check-in) counters inside of airports, shopping malls, or public buildings. In an emergency response situation indoor navigation could provide escape routes from buildings and fastest routes for rescue personnel to a disaster area [7].

In general, navigation comprises 1) the determination of the location of a subject or object, 2) the determination of the best path (often the fastest, the shortest, or the cheapest) from a start to an end location, and 3) guidance along the path which includes monitoring of the difference between the current position and the path and enforcement of appropriate actions to minimize the difference. Thus, in order to facilitate indoor navigation the problem of data availability on the indoor navigable space has to be solved and appropriate localization techniques and methods need to be developed.

In the past, different models for structuring indoor space and localization methods have been proposed. As we will discuss in sections 2 and 3, in most cases space is partitioned due to route planning and addressing criteria on the one hand and localization technology and sensor characteristics on the other hand. Often they are mixed within one model, which has the disadvantage that changes to the building structure or sensor configurations may affect the entire model. For example, changes to room topology (e.g., a door will be closed permanently or a new door will be installed within a wall) does not necessarily have an impact on the localization infrastructure like Wi-Fi access points or RFID sensors and vice-versa.

In section 4 we present a new framework in which different concepts of space are combined to a multilayer space-event model. One concrete concept of space deals with the 3D topographical representation of buildings and another with the 3D representation of sensor and transmitter placements and ranges. While the first will facilitate route planning, the second will facilitate localization; both together then facilitate navigation. Each space concept is separated into primal and dual space on the one side and geometry representation and topology on the other side. The different space concepts are then linked by an n-partite graph where nodes represent spaces and the states of a guided subject or object at the same time. Edges represent events like leaving or entering a room (in topographic space) or

change of signal strength within the range of a transmitter (in sensor space). The actual position is given by the so-called joint state, which helps to reduce uncertainty about the true absolute position in real space.

Finally, in section 5 we draw some conclusions and point to future work.

2. Related work

Substantial work has already been done in the area of indoor navigation. In the following, we give a brief overview of current developments on specific systems and underlying information structures needed in order to support location services and route planning in indoor environments.

The OntoNav system [3] describes a semantic indoor navigation system. It proposes an indoor navigation ontology which provides semantic descriptions of the constituent elements of navigation paths such as obstacles, exits, and passages. Furthermore, specific user capabilities/limitations are modeled allowing for a user-centric navigation paradigm and the application of reasoning functionality.

In the field of mobile robot navigation, Kulyukin et al. [4] present an indoor navigation system for assisting the visually impaired. The system is designed as a tool to help visually impaired customers navigate a typical grocery store using a robot shopping cart. For localization, the system relies on RFID tags deployed at various locations in the store.

In order to simplify complex spatial relationships between 3D objects in built environment, Lee [6] introduces a topological data model, the Node-Relation-Structure (NRS). The NRS is a dual graph representing the connectivity relationships between 3D entities by Poincaré Duality. In the context of emergency response, Lee et al. [7] show the use of this simplified NRS representation of the indoor environment for routing purposes.

Within the REWERSE project, Lorenz et al. [2] provide an approach for the automated partitioning of the building interior not only into rooms, but also into smaller parts, so called cells. The internal structure of the building is hence represented as a hierarchical graph enabling localization and route planning on different levels of detail. The partitioning is based on the automatic cell-and-portal decomposition of polygonal scenes proposed by Lefebvre and Hornus [5].

Liao et al. [13] propose an approach to track moving objects and their identity in indoor environments. Based on a Voronoi graph providing a natural discretization of the environment, the locations of people are esti-

mated using noisy, sparse information collected by id-sensors such as infrared and ultrasound badge systems.

Kolodziej [9] provides a comprehensive overview and discussion of existing technologies and systems in the context of indoor navigation. Various approaches and algorithms for indoor localization using different kinds of sensor systems are described, which form the basis for Location Based Services (LBS).

3. Detailed analysis of previous approaches

In this section, some of the approaches mentioned in section 2 are revisited and analyzed in more detail with focus on their geometric and topological representation of indoor space. It is assumed, that for the realization of localization and navigation systems the built environment such as a building is represented geometrically in Euclidean space, particularly in \mathbb{R}^3 . Therefore, a building can be described using geometric and topological representations defined in ISO 19107 [1].

The Node-Relation-Structure (NRS)

The Node-Relation-Structure (NRS) proposed by Lee [6, 7] is a data model which allows for a simplified representation of the complex topological relationships between 3D spatial objects in indoor environments, such as rooms within a building. These relationships, i.e., adjacency and connectivity relations, are directly derived from 3D geometry and topology of the interior entities. They are transformed into a dual graph structure in topology space using the Poincaré Duality. The dual graph enables the efficient implementation of complex computational problems within indoor navigation and routing systems.

Poincaré Duality

The NRS utilizes the Poincaré Duality in order to simplify the complex spatial relationships between 3D objects by a combinatorial topological network model. Solid 3D objects in primal space, e.g., rooms within a building, are mapped to vertices (0D) in dual space. The common 2D face shared by two solid objects is transformed into an edge (1D) linking two vertices in dual space. Thus, edges of the dual graph represent adjacency and connectivity relationships which may correspond to doors, windows, or hatches between rooms in primal space. Fig. 3.1 illustrates this duality

transformation. A formal definition of the Poincaré Duality is given by Munkres [8].

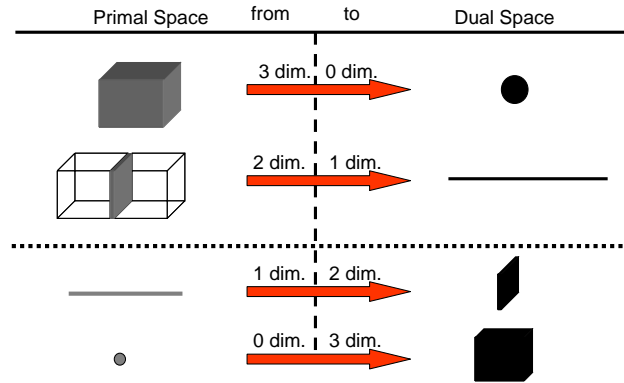

Fig. 3.1 Principles of Poincaré duality as shown by Lee [6]; for further information on the mathematical definition of Poincaré duality, see [8]

Since the resulting combinatorial model only represents topological relations, it does not contain metric information. However, metric information is needed in order to implement 3D spatial queries in the NRS such as shortest path operations. For this purpose, a complementary geometric network model is derived in Euclidean space by applying mathematical skeletonization algorithms and centroid calculations to the 3D spatial objects. By relating both graph representations, a geometric-topological network model can be established applicable to complex 3D spatial queries.

Fig. 3.2 illustrates the approach of Lee in a way that allows for the distinct separation of primal space from dual space on the one hand, and geometry and topology on the other hand. This structure forms the basis for the framework proposed in the next section. The NRS data model supports the implementation of indoor navigation systems, e.g., in the context of emergency response, since the complete indoor environment of a building is described by a graph with an embedding in \mathbb{IR}^3 . This graph represents topological adjacency and connectivity relationships between spatial objects as well as metric information. Accordingly, methods for indoor routing can be efficiently applied.

Generally, the dual representation of the indoor environment can be understood as a room-to-room connectivity graph. However, indoor navigation approaches like those proposed by OntoNav [3] and Lorenz [2, 17] rely on a further spatial decomposition of rooms according to the modus of navigation, e.g., to represent navigable and non-navigable areas with re-

spect to the capabilities and limitations of moving persons. Moreover, the partitioning of indoor space into smaller units may also be induced by limited propagation areas of sensor-based positioning systems, e.g., systems based on RFID tags, which do not cover the spatial extent of an entire room.

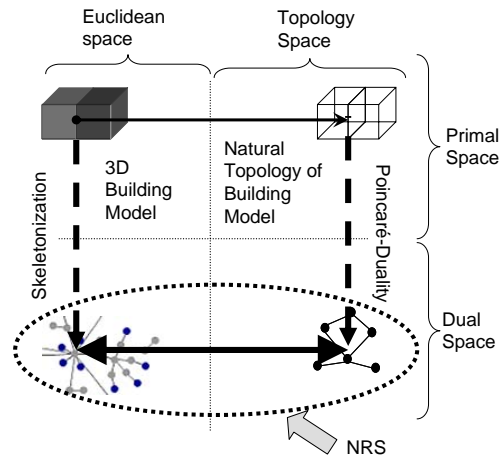

Fig. 3.2 graphical summary of Lee's approach

The need for the decomposition of rooms into smaller units

In semantic 3D building models, the free space within buildings is modeled by non-overlapping room objects (see [10, 11]). Whereas this representation of indoor environment is suitable for the derivation of a room-to-room connectivity graph, Lorenz [2] and Lefebvre [5] propose a more differentiated decomposition of the semantic room entities. The room itself is geometrically fragmented into so-called cells, which again represent non-overlapping parts of the room. Based on the topological relationships of the resulting cells, a cell-to-cell connectivity graph can be derived by applying the duality transformation proposed by Lee [7].

The importance of a fine-grained subdivision of space and its dual cell-to-cell representation is exemplified within a fire escape scenario illustrated in fig. 3.3. The figure shows several rooms connected by doors to a corridor. Whereas in 3.3a) no further partitioning is applied to the topographic room objects, the corridor in 3.3b) is subdivided into disjoint cells representing partially accessible passages of the corridor with respect to adjacent doors. The corresponding dual graph representations are also shown in fig. 3.3. The task within this fire scenario is to find an evacuation

route from the upper left room to the staircase. As a constraint for the modulus of navigation, rooms affected by fire, i.e., the left part of the corridor, are marked as non-navigable.

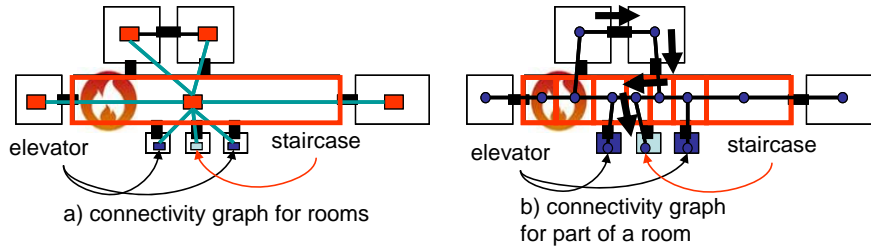

Fig. 3.3 The effect of spatial decomposition of rooms along escape routes

Based on the room-to-room connectivity graph, this task cannot be performed since the corridor is only represented by a single vertex in the dual graph and is completely marked as non-navigable. However, the semantic decomposition of the corridor into single cells allows for its dual representation by several vertices. Since only two cells are affected by fire and thus marked as non-navigable, a valid escape route can be computed based on the cell-to-cell connectivity graph (denoted using black arrows in fig. 3.3b).

Smaller partitions of topographic space and the corresponding semantic decomposition of room objects provide the necessary means for a more precise indoor route planning. Although the approach of Lee [7] introduces a multi-scale representation of spatial objects within the geometric network model, this representation is the result of skeletonization processes of 3D spatial objects in Euclidean space (see fig. 3.2), and thus does not follow semantic decompositions as proposed by Lorenz et al. [2, 17]. As shown in the previous example, these decompositions of room space allow for a more detailed planning of escape routes.

Furthermore, the single partitions can be individually addressed by sensor-based positioning and tracking systems to provide a more accurate location of moving subjects or objects. Lorenz et al. [2] describe such a system by integrating a Wi-Fi sensor model using so-called fingerprints. Fingerprints represent measurements of the signal strength of Wi-Fi transmitters at discrete locations within a room (see fig. 3.4). The cell decomposition of the room is performed based on different fingerprint measurements which are modeled as attributes of room cells. This approach allows for localization within rooms. However, the illustrated modeling approach also faces substantial disadvantages. Since the partitioning of topographic Euclidean space follows the characteristics of sensor space, there is no

separation of the different space concepts any more. Instead of a spatial partitioning of topographic space according to geometrical, semantic or rule-based aspects, the decomposition is decisively influenced by the sensor model, e.g., by the received signal strength of the transmitter or signal source.

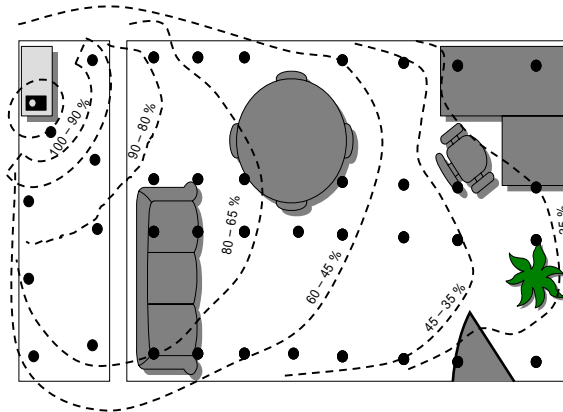

Fig. 3.4 Signal propagation area of a Wi-Fi transmitter including discrete areas of different signal strength and measurement points

Accordingly, both space representations cannot be modeled individually. Changes to building topology or sensor configuration would both affect the entire structure. Furthermore, the integration of another kind of sensors or transmitters, e.g., RFID tags within a Wi-Fi based system, induces further modeling complexities, since the same room cell in topographic space could be covered by various overlapping sensor propagation areas, e.g., based on Wi-Fi signal strength and RFID signal strength.

4. The proposed model

Due to limitations of existing modeling approaches discussed in the previous sections, we propose a novel framework for a multilayer space-event representation. A crucial aspect of this framework is the clear separation of different space models, e.g., topographic space and sensor space. This approach allows for the decomposition of a specific space into smaller units according to respective semantics, without influencing other space representations. Furthermore, we show how to connect the layers, i.e., space models, in a well-defined way and to derive a valid and unique joint state

embracing all linked layers at a given point in time. Based on joint states, e.g., between topographic space and sensor space, the proposed multilayer modeling approach can be utilized to enable localization and route planning strategies. Fig. 4.1 illustrates the proposed modeling framework.

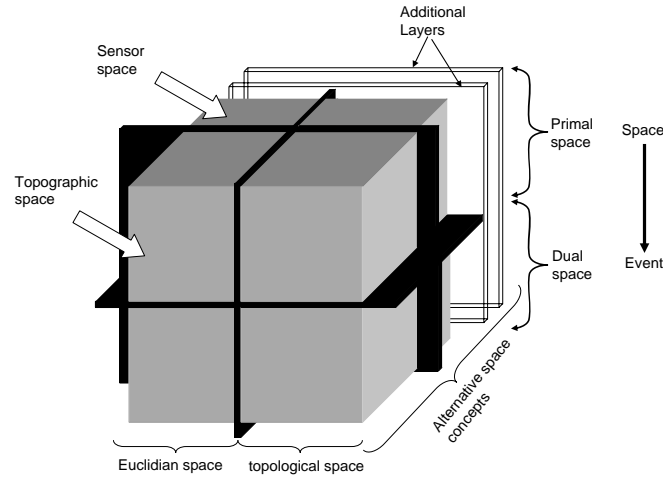

Fig. 4.1 Multilayer combination of alternative space concepts

Within the framework, alternative space models are represented as separate layers. In fig. 4.1, the layer to the front exemplarily represents topographic space, whereas the sensor space is depicted by the layer in the back. Each layer can further be divided into four segments (indicated by black cutting planes). The vertical division corresponds to space representations within Euclidean space respective topology space on the one hand. The horizontal partitioning indicates primal and dual space on the other hand. Consequently, each space model is given by four distinct space representations.

The separation of layers results from different space models with different partitioning schemas. For example, in topographic space geo-objects such as buildings may be represented using semantic 3D building models (see [10, 12]). Further semantic decompositions into, e.g., rooms, walls, doors, etc. can be applied within these model. However, the notion of sensor space substantially differs from topographic space. The sensor space is rather decomposed according to signal characteristics such as propagation and signal coverage areas. Besides topographic and sensor space, further alternative concepts of space can be incorporated into the framework by adding additional layers. The number of layers is unbounded. For example, in the area of philosophy different definitions for space (e.g., movement

space, activity space, visual space etc.) can be encountered which can also be used to describe a built environment. However, the notion of space and its semantic decomposition again differs from topographic or sensor space. Since each layer provides a valid and consistent representation of space, the common framework itself is to be seen as a valid multi-layered space representation, which can be used as a whole to describe, for example, the indoor environment of buildings.

For each layer, topological relationships such as connectivity and adjacency relations between 3D spatial objects are represented within topology space (i.e., the right side of fig. 4.1). In primal space, topology is induced by the corresponding 3D geometry in Euclidean space. By applying a duality transformation based on Poincaré duality, the 3D cells in primal topology space are mapped to nodes (0D) in dual space. The topological adjacency relationships between 3D cells are transformed to edges (1D) linking pairs of nodes in dual space. The resulting dual graph represents a Node-Relation-Structure as proposed by Lee [7]. Furthermore, the dual graph can also be seen as a state transition diagram. The active state is represented by a node within the dual graph and denotes the spatial area the guided subject or object is currently in. Once the subject or object moves into a topologically connected area, another node within the dual graph and thus a new active state is reached. The edge connecting both nodes represents the event of this state transition. Therefore, events are related to the movement of subjects or objects through the explicit topological representation of space. Accordingly, our modeling approach is a space-event model. Under the assumption that the space is subdivided into disjoint areas, exactly one node within the NRS respectively the state transition diagram can be active.

4.1 Topographic Space / Layer

The topographic layer is illustrated in fig. 4.2. For indoor navigation, the topographic space represents the interior environment of buildings and its semantic decomposition into building elements like rooms and doors in order to enable route planning. Semantic building models for the representation of topographic 3D objects nowadays become increasingly available in the context of Building Information Modeling (BIM), such as the Industry Foundation Classes (IFC) [12] and in the field of 3D city modeling. The City Geography Markup Language (CityGML) [10, 11] defines a geo-spatial information model for the representation of 3D topographic urban objects including buildings.

According to the general space concept of layers, the topographic space can be described by four distinct representations. The upper left element of fig. 4.2 illustrates the non-overlapping 3D geometry representation of built environment in Euclidean space. This geometry information can be directly derived from IFC and CityGML building models. The upper right element represents the induced natural topology of the 3D spatial objects according to ISO 19107. Since disjoint partitioning of Euclidean space is assumed, the relation between both upper elements can be expressed with the “Realization” association between geometric and topological objects defined by ISO 19107. Accordingly, associated objects in either space must share a common dimension and are related by 1:1.

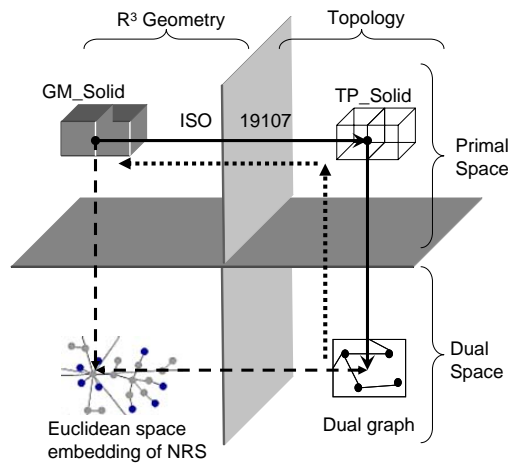

Fig. 4.2 The topographic space

Whereas the upper part of fig. 4.2 represents the primal Euclidean respectively topology space, their dual representations are depicted by both lower elements. For the lower right part, topology is represented as dual graph based on the NRS model and is derived from topology in primal space by Poincaré duality transformation. As mentioned in section 3, the NRS does not contain metric information which is, however, necessary in terms of spatial 3D queries such as shortest path calculation. In order to integrate metrics, one possible solution could be the usage of the methods “representativePoint()” and “centroid()” defined for GM_Objects in ISO 19107. For 3D solids, these methods return a point geometry representing the centroid of the volumetric object. This point representation could be stored attributively within the NRS. Since nodes of the NRS are directly related to TP_Solids in primal topology space, which, in turn, are directly related to

GM_Solids in primal Euclidean space (depicted by dotted arrows in fig. 4.2), this metric information can be uniquely derived. Furthermore, weights representing, for example, distances between rooms can be assigned to the edges of the NRS. These weights could be derived from primal Euclidean space accordingly.

The lower left element of the topographic layer finally represents the Euclidean space embedding of the NRS. The dual transformation of Euclidean space results in a geometric network model [7]. This dual graph representation is derived by mathematical functions such as skeletonization processes.

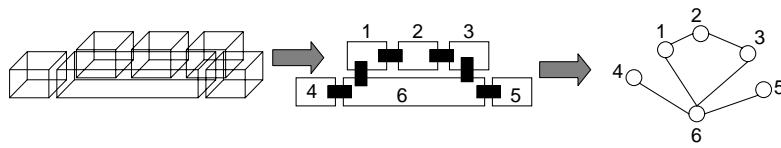

Fig. 4.3 Example for the partitioning of building interior into rooms and its representation in dual space

4.2 Sensor Space / Layer

The concept of space-event modeling allows for consistent specification and interpretation of various space concepts. This ensures equivalent interpretations of sensor space and topographic space. When arranging sensors within a building (e.g., Wi-Fi), transmission ranges may overlap, which requires their decomposition into disjoint regions in order to define unambiguous states. As a state one can define the range or different signal strength areas. The event can be understood as an entry into a sensor area or as the crossing of a certain threshold value.

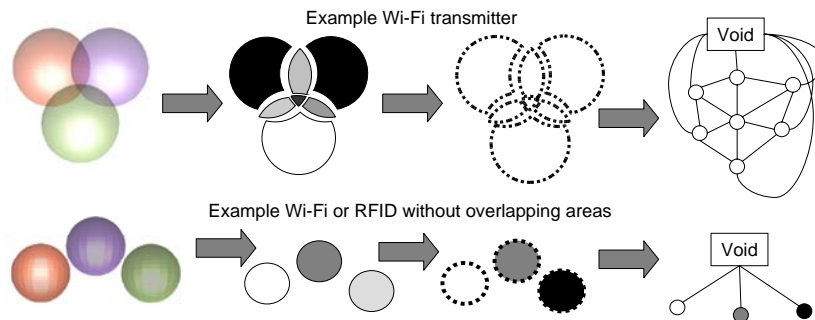

Fig. 4.4 Example for partitioning into cells and their representation in dual space

Like in the topographic layer, the accuracy of positioning correlates to the granularity of partitioning. Hence with smaller cells, navigation gains in precision.

To describe areas with no sensor coverage, an additional state called “void” is defined for every sensor system. This state is needed when the navigating subject or object leaves the range of a sensor without other sensors around, e.g., when leaving the building. For sensor systems covering the whole interior building area, the state “void” only represents the outside building environment. Fig. 4.4 illustrates the modeling of sensor space in the case of overlapping transmitter/sensor ranges.

Fig. 4.5 further specifies different geometric and topological representations of sensor space.

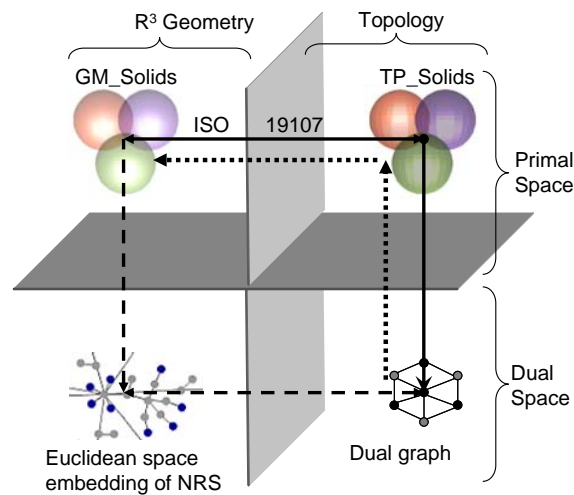

Fig. 4.5 Sensor space

In \mathbb{R}^3 , the partitioned sensor areas are represented as GM_Solids (upper left part) and their topological representation as TP_Solids (upper right part). The two representations are linked by the “Realization” association defined in ISO 19107. The Poincaré Duality defines the mapping from the topological representation to a dual graph structure (lower right part), representing a state transition diagram. To allow for quantitative evaluation of state distances, a metric is needed within the graph structure (like in the topographic layer). This metric is defined by explicit linking of nodes and corresponding GM_Solid objects. The distances between GM_Solids are then assigned attributively to the graph edges, resulting in a geometrical network of sensors in \mathbb{R}^3 (lower left part). The link between GM_Solids and the sensor network (both defined in Euclidean space) embodies poten-

tial mathematical algorithms for network derivation, e.g., Delaunay Triangulation, Voronoi Diagram, etc.

4.3 Decomposition of buildings

As shown in fig. 4.6, a building can be partitioned within Euclidean space into smaller units both on the layer of sensor space and the layer of topographic space. The coexistent spaces of a building have their respective correspondence in dual space. Hence, a 3D cell in primal space has its own representation as a node in dual space. The cellular space (outlined with a dashed rectangle) is given by the set of smallest units (cells) of these partitions. The smallest unit of a partition may be a part of a room but also a complete room. As indicated in fig. 4.6, the decomposition can be hierarchical. However, only the smallest units (cells) are considered in the following.

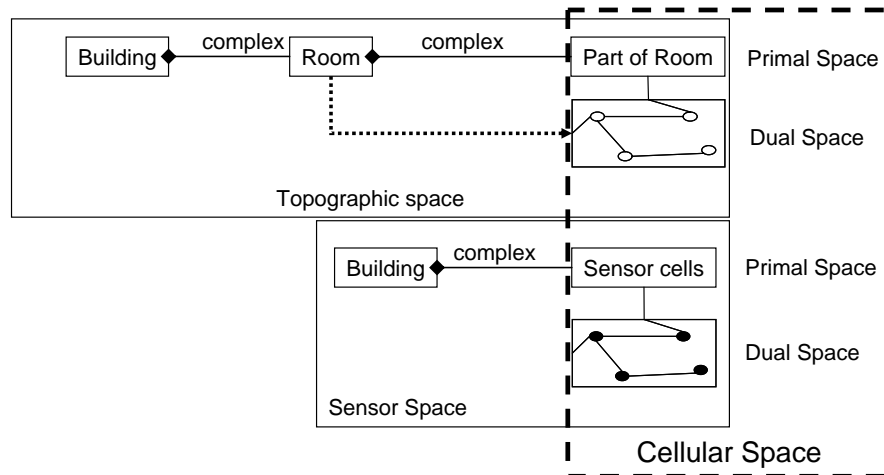

Fig. 4.6 The decomposition approach of a building

4.4 Connecting all N space layers by a N-partite graph

As was illustrated before, the node-relation-structure NRS (bottom right in fig.s 4.1, 4.2, 4.4) within each layer constitutes a graph. The nodes represent the possible states of a navigating subject or object and correspond to cells with volumetric extent in primal space while the edges represent state

transitions, i.e., events caused by the movement of a subject or object. They correspond to adjacency relations between the cells in primal space within the same space model (e.g., neighbored rooms in topographic space).

If we assume that each space model is based upon a disjoint partitioning of (Euclidean) space, a navigating subject or object can only belong to one cell at a time and thus always only one state may be active. Since we have different space layers with different partitioning, each layer contains such a state transition graph with exactly one active state. The overall state is then given by the joint state of all space models, i.e., all layers.

However, only certain combinations of states between different layers are valid. These combinations are expressed by additional edges between the nodes of different layers. These edges are called *joint-state edges*. The overall structure then constitutes an N-partite graph, where all the nodes from all N layers are included but are separated into N partitions which are connected by the joint-state edges. Furthermore, the graph also contains the state transition (or cell adjacency) edges. This is illustrated in fig. 4.7 which shows an example with three space models / layers. The dashed lines represent state transitions / cell adjacencies within the layers and the continuous lines joint-state edges between different layers.

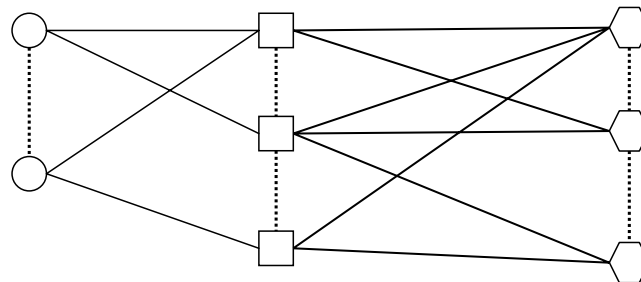

Fig. 4.7 Example for a tripartite graph containing nodes from three layers. Nodes of different layers are connected by joint-state edges. Only one state in each partition can be active and active states must be connected to each other by joint-state edges. The dashed edges represent cell adjacencies within each layer.

The joint-state edges can be automatically derived by pair wise intersection of the respective geometries between different layers. If the intersection of the interior of a cell from one space model (layer) with the interior of a cell from another space model is non-empty, a joint-state edge exists between the corresponding nodes of the respective NRS. In other words, if two cells from different space models do not overlap or are contained within each other there will be no valid joint-state in which these nodes are active at the same time.

Connections between both layers

Not only the nodes of the NRS between different layers can be combined, but also connections between layers of the other three quadrants (cf. fig. 4.1) can be useful. For example, the connection of the geometries in primal space (see connection of upper left parts in fig. 4.8) would allow for a common 3D visualization within Euclidean space. If geometry is represented according to ISO 19107 in \mathbb{IR}^3 the spaces are represented as GM_Solid objects which can be visualized together in one 3D scene. This is illustrated in fig. 4.9 where both the building topography and the position and range of transmitters and sensors are shown.

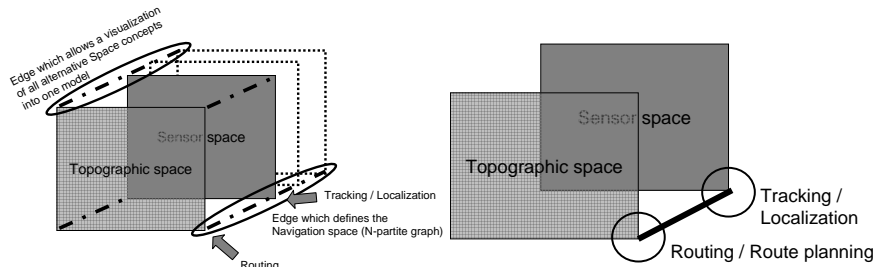

Fig. 4.8 Connection between layers (left); especially for topographic and sensor space (right)

The dashed edges between the different layers in fig. 4.8 comprise not only the possibility of a common visualization, but generally define additional constraints to the model. They enforce an identical spatial reference system and the possibility of determining the absolute position in 3D space within a building.

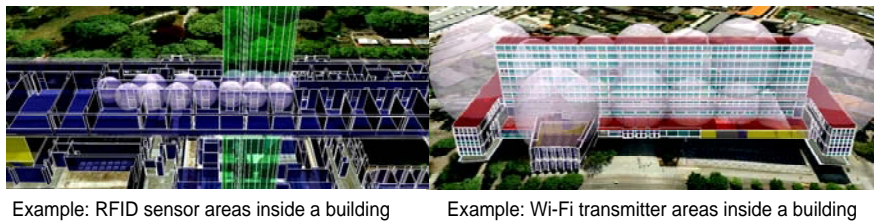

Fig. 4.9 Examples for combined visualizations (left: RFID; right: Wi-Fi)

The NRS of topographic space, marked by the lower circle on the right side of fig. 4.8, facilitates route planning within the building. Therefore, it is already useful for itself for emergency planners in order to calculate escape routes without the need for an additional sensor model. On the other

side the NRS of sensor space, marked by the upper circle on the right side of fig. 4.8, can be used in a decoupled way for tracking and localization without knowing the actual position in topographic space. The edge between the two NRS denotes the joint-state connection combining both graphs to the N-partite graph (in this example a bipartite graph) which defines the valid states of the entire model. The existence of this joint-state connection not only allows the determination of relative positions with respect to a sensor, but also the absolute position determination within the sensor and topographic space. The uncertainty about the absolute position in Euclidean space can be restricted to the intersection volume of all 3D cell geometries associated with the active nodes in the joint-state.

In addition, the N-partite graph allows also for assessment of localization infrastructure and estimation of location uncertainty with a given building decomposition in topographic space and a given sensor / transmitter configuration in sensor space.

4.5 Example for Modeling Proposal

The following example illustrates the representation of a building floor both in topographic space and sensor space. It demonstrates how geometrical-topological representations are mapped to dual space and which joint-state edges are established within the N-partite graph.

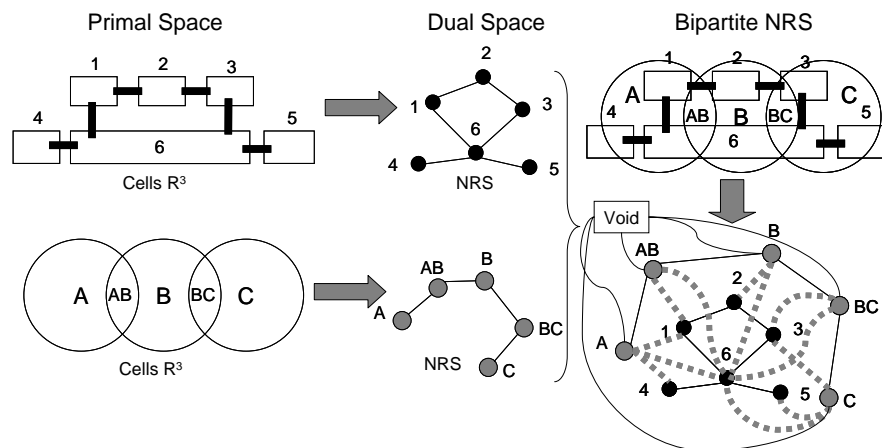

Fig. 4.10 Simple example for modeling building space by using bipartite graph

In fig. 4.10 a building floor consisting of 6 rooms is shown. The entire floor is covered by signals of three Wi-Fi access points. Since the ranges of the access points A, B, and C overlap, the range geometries are parti-

tioned accordingly into A, AB, B, BC, and C. From the dual space transformation the bipartite graph at the bottom right is derived. The joint-state edges are drawn by dashed lines. They indicate for example, that node 4 can be jointly active only with node A. The other type of edges marks adjacencies (and possible state transitions in each space model).

Now, if one moves from cell 4 to cell 3 in topographic layer, one must pass the cells 1 and 2 or 6 in this layer. In the sensor layer one passes the cells A, AB, B, BC, and C. In fig. 4.11 a joint-state for a given location is highlighted. Sensor events indicate movement and will lead to respective state transitions. By using the joint-state edges the possible locations can then be restricted to those cells in topographic space which are connected to the new state in sensor space by an edge. The investigation of further properties of and constraints implied by the N-partite graph will be the subject of future work.

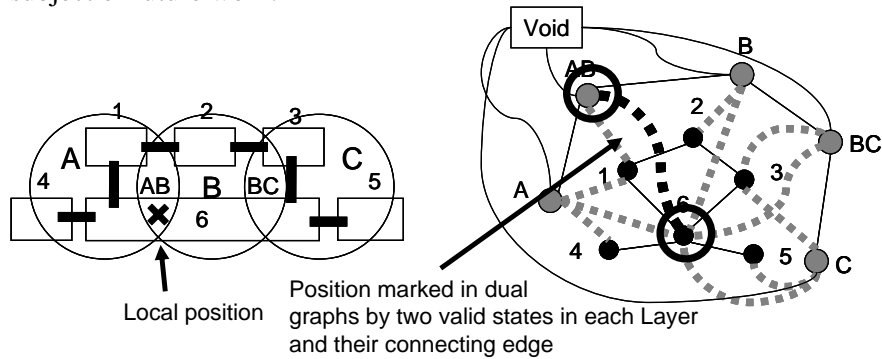

Fig. 4.11 Example for a joint state; for each partition of the bipartite graph only one state is active and the active states are connected by a joint-state edge

5. Conclusion and Outlook

We have presented a novel concept for the modeling of indoor spaces to be used for route planning and localization/tracking within indoor navigation systems. The concept extends previous work from Lee [6, 7] and others [2, 3] to a multilayer representation of specific decompositions of buildings according to different semantic criteria. As an example the decomposition of 3D building models within topographic space and the representation of transmitters and sensors within a distinct sensor space were introduced and discussed. The model reflects the duality of space and events by means of the Poincaré duality of topological models. Nodes in dual space represent possible states of a navigating subject or object. Joint-states between the

different space models mutually constrain possible locations in either space model. The advantage of the multilayered representation is that space models for different sensors and topography can be represented independently from each other and that changes to one of the models do not affect the structure of the other models.

In the future, we intend to further examine the properties of the N-partite graph. First, different “void” nodes may be distinguished denoting different disconnected areas which do not provide sensor coverage but which may only be reached by crossing certain sensor / transmitter ranges. Second, it should be investigated how the structure can be used to plan sensor / transmitter deployment. By both means uncertainty of localization can be minimized.

Acknowledgements

The presented work was mainly carried out within the collaboration project “Indoor Spatial Awareness” funded by the Ministry of Transportation and Construction of South Korea. We thank Ki-Joune Li and Jiyeong Lee for fruitful discussions.

References

1. Herring, J., 2001. The OpenGIS Abstract Specification, Topic 1: Feature Geometry (ISO 19107 Spatial Schema), Version 5. OGC Document Number 01-101. / prepared by Technical Committee ISO/TC211 Geographic information — spatial schema, available at:
http://www.iso.org/iso/iso_catalogue/catalogue_tc/catalogue_tc_browse.htm
2. Lorenz, B., Ohlbach, H. J., Stoffel, E.-P., Rosner, M., September 2006, NL Navigation Commands from Indoor WLAN fingerprinting position data, Technical Report of REWERSE-Project, Munich, Germany
<http://www.pms.ifi.lmu.de/publikationen/idefixStatic/reverse-publications.html#REWERSE-DEL-2006-A1-D7>, (Accessed June 2008),
3. Anagnostopoulos, C., Testos, V., Kikiras, P., Hadjiefthymiades, S. P., 2003. OntoNav: A Semantic Indoor Navigation System. In: First International Workshop on Managing Context Information in Mobile and Pervasive Environments, Vol. 165, Ayia Napa, Zypern
4. Kulyukin, V., Gharpure, C., Nicholson, J., 2005. RoboCart: Toward Robot-Assisted Navigation of Grocery Stores by the Visually Impaired. In: Proceedings of the international Conference on Intelligent Robots and Systems, IROS 2005, IEEE/RSJ

5. Lefebvre S, Hornus S. Automatic cell-and-portal decomposition. Technical Report 4898, INRIA, 2003. <http://artis.imag.fr/Publications/2003/LH03/> (Accessed June 2008).
6. Lee, J., 2004. 3D GIS for Geo-coding Human Activity in Micro-scale Urban Environments. In: M.J. Egenhofer, C. Freksa, and H.J. Miller (Eds.): GIS-science 2004, Springer, Berlin, Germany
7. Lee, Y., Zlatanova, S., 2008. A 3D data model and topological analyses for emergency response in urban areas. Geospatial Information Technology for Emergency Response – Zlatanova & Li (eds), Taylor & Francis Group, London, UK
8. Munkres, J. R., 1984. Elements of Algebraic Topology. Addison-Wesley, Menlo Park, CA
9. Kolodziej, K. W., Hjelm, J., 2006, Local Positioning Systems – LBS Applications and Services, Taylor & Francis Group, London, UK
10. Gröger, G., Kolbe, T.H., Czerwinski, A., 2007: OpenGIS City Geography Markup Language (CityGML), Version 0.4.0, OGC Best Practices Paper Doc. No. 07-062
11. Kolbe, T.H., Gröger, G. & Plümer, L. 2005. CityGML – Interoperable Access to 3D City Models. In P. van Oosterom, S. Zlatanova & E.M. Fendel (eds), Geo-information for Disaster Management; Proc. of the 1st International Symposium on Geo-information for Disaster Management', Delft, The Netherlands, March 21–23, 2005. Springer.
12. Adachi, Y., Forester, J., Hyvarinen, J., Karstila, K., Liebich, T., Wix, J. 2003. Industry Foundation Classes IFC2x Edition 3, International Alliance for Interoperability, <http://www.iai-international.org>.
13. Liao, L., Fox, D., Hightower, J. Kautz, H., Schulz, D., 2003. Voronoi Tracking: Location Estimation Using Sparse and Noisy Sensor Data. In: Proc. of the International Conference on Intelligent Robots and Systems, IROS 2003, IEEE/RSJ
14. Lewin, B., Cassimeris, L., Lingappa, V. R., Plopper, G., 2006. Cells. Jones & Bartlett, USA
15. Mishra, A. R., 2004. Fundamentals of Cellular Network Planning and Optimisation. John Wiley & Sons, Chichester, UK
16. LaValle, S. M, 2006. Planning Algorithms. Cambridge University Press, USA
17. Lorenz, B., Ohlbach, H. J., Stoffel, E.-P., Rosner, M., September 2007. Towards a Semantic Spatial Model for Pedestrian Indoor Navigation. In: Lecture Notes in Computer Science - Advances in Conceptual Modeling – Foundations and Applications, Volume 4802/2007, Springer, Berlin, Germany