

Neurorobotic Mouse (NeRmo) V4.1

P. Lucas¹, F. O. Morin¹, J. Conradt² and A. Knoll¹

1. Chair of Robotics, Artificial Intelligence and Real-time Systems

Technical University Munich

peer.lucas@tum.de, morinf@in.tum.de, K@tum.de

2. Division of Computational Science and Technology

Royal Institute of Technology in Stockholm

jconradt@kth.se

Abstract

This report describes the final version of the Neurorobotic Mouse robot, also called NeRmo. This biomimetic robot is modular and low-cost; it was created to mimic the locomotion of a rodent and has the size of a common rat (*Rattus norvegicus*). The robot is untethered, easy to use and simple to produce; it thus can be used as a universal research platform. It is based on tendon-driven actuation, which enables the implementation of a compliant leg and body design and thus enables adaptive and dynamic walking motions. Small biomimetic robots can be useful for behavioural/social studies in combination with animals, or for investigating new, efficient types of locomotion for exploration systems. Combined with digital twins, they are a useful tool to reduce the reality gap between simulation and the real world.

Index Terms

Robot rodent, locomotion, biomimetic, compliant robotics, tendon-driven actuation, digital twin

I. INTRODUCTION

This report describes the evolution of the so-called Neurorobotic mouse robot (NeRmo) and presents the main features of its latest release. The development of that robot was initiated in 2018 [1] with the goal of becoming a general-purpose research robot for roboticists and neuroscientists alike. Over the last two years, four main successive versions [2] were built before obtaining the final version described here.

The minimal set of features for such a robot to be useful to all intended users [2] are:

- Flexible and functional backbones.
- Biologically relevant limbs with a small number of parts (for ease for build).
- A functional tail (for facilitating balance and locomotion).
- A sensory system sufficient to provide the robot with capabilities for autonomous navigation and decision-making.
- Tendon-driven actuation that mimics the biological musculoskeletal system of a rodent.

Additionally, the prerequisites for this project were to create a low-cost and modular robot, in order to facilitate uptake of the device in the research community. These features were already realised with the last version of this robot [2]. The final version, presented here, features multiple improvements over previous iterations, especially ease of assembly and robustness, to get a wider user group. Additionally, we created a digital twin of the robot (i.e. a simulated model, reproducing the characteristics of the real one, with as much fidelity as possible) inside the Neurorobotics Platform (NRP).

II. ROBOT DESIGN

A. General description

The specifications of the complete robot can be found in Table I. The dimensions are similar to those of the common rat *Rattus norvegicus*, which is 370 to 440 mm long including the tail, and weighs between 250 and 400 g.

Figure 1 shows the robot in an exploded view with the base modules separated. All technical illustrations were created using Autodesk® Inventor® Professional 2020. The central body frame of the robot serves as mounting frame for all extremities like tail, head and legs. It also holds a separate frame for the battery, a raspberry pi computer and a connected custom made "spine" adapter board with its own micro controller, enabling the electrical connection to all sensors and actors. This frame can be removed from the main body frame, for easier assembly.

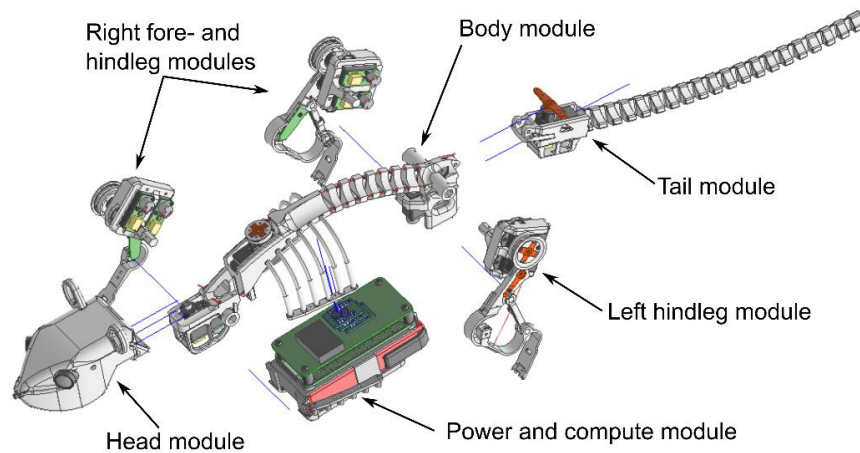

Figure 1 Exploded view of the robot.

On top of serving as a mounting frame, the central frame also possesses two degrees of freedom. One flexes the spine on a lateral plane, allowing the robot to turn left and right; this is achieved by a servo pulling two tendons attached to five flexible hinges. Another flexes the spine vertically, allowing the robot to stretch and arch its back, thus shifting the robot's centre of gravity, changing the robot's stability and allowing it to remain in a sitting up position. This motion is achieved by actuating four flexible hinges via one tendon. Both tendon pathways can be seen in Figure 2. The tail is actuated for lateral movement via one actuator moving tendons that in turn actuate 21 separate flexible joints. It can also be passively moved vertically up and down, so that the robot can reach a sitting position.

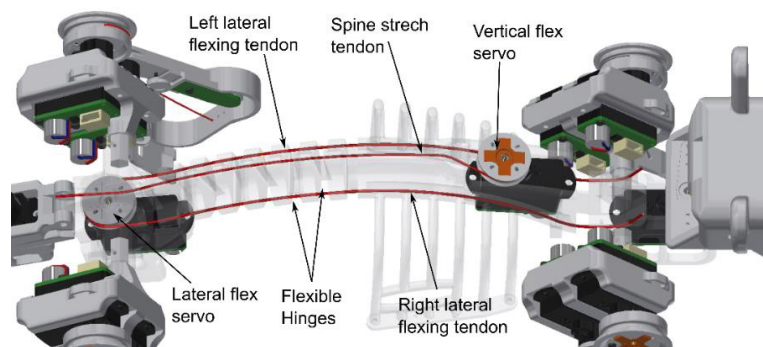

Figure 2 Tendons to actuate the Spine.

The complete robot with the sensors labelled can be seen in Figure 3. The head holds two HD cameras, a button on the nose and a touch sensor on the top of the head. The two cameras are connected to the USB port of the Raspberry Pi via a USB hub also located within the Head. The buttons are connected to the spine adapter board.

Sensory proprioception is enabled through the custom servo motors which allow for feedback on motor position and current draw, as well as an IMU sensor on the spine adapter board. For this final version the focus was set on: 1) ensuring the overall stability of the robot; and 2) protecting the electronics and motors against accidental destruction and failure due to repeated efforts. All servos attached within the central body frame are encased so no electronic parts face outside. The wiring harness is connected via plugs, so no soldering is necessary during assembly. It is also mostly contained within the rib cage, so accidental tangling is prevented. Additionally, the head was moved down relatively to the body to be more biologically accurate.

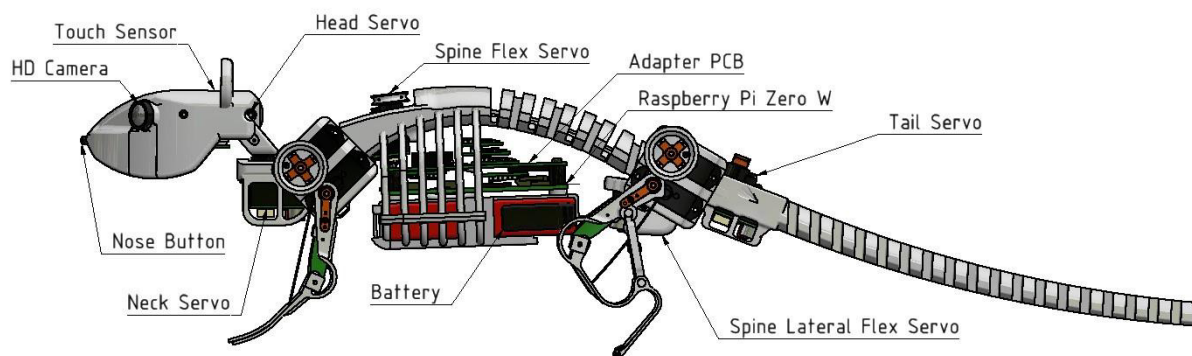

Figure 3: Side view of NeRmo robot with the major parts labelled.

The Legs were redesigned from the first version, to allow for a simpler manufacturing process and to be more robust to daily use. They also include position sensors and ground pressure sensors. They will be discussed in detail in the next section.

Table 1 ROBOT SPECIFICATIONS

| | | |
|------------|-----------------------------|---|
| Joints | Actuated Degrees of Freedom | 13 |
| | Elastic Joints | 27 |
| Dimensions | Size | 405 x 91 x 90 [mm] |
| | Length Scapula-pelvis | 117 [mm] |
| | Weight | 275 [g] |
| | Speed | ≈ 0.3 m/s |
| Electrical | Battery | 7,4 V 1000 mAh LiPo |
| | Run Time | ≈ 25 min continuous walking |
| | Connectivity | 2.4GHz 802.11n WLAN |
| Sensors | Actuators | Every actuator can provide position and current |
| | Legs | Knee/Elbow Angle |
| | Feet | Ground Pressure |
| | Body | IMU, Battery state |
| | Buttons | Nose and Head |
| | Head | Two wide Angle HD Cameras |
| Cost | ≈ €1000 | |

B. Leg Design

Compared to the first version of this robot as described in [1] the pantograph leg mechanism was simplified [2] and is described in more detail hereafter. The previous leg joints knee and ankle were replaced by flexible sections in order to reduce part complexity and remove the mechanical springs. The ankle joint was split into two flexible areas, which allowed for the pantograph leg actuation of the previous configuration while maintaining a decoupled elasticity that enables the foot to adapt to the ground; this enables it to always stay flat on the ground for more efficient locomotion. Figure 4 shows the redesigned leg with the labelled anatomy.

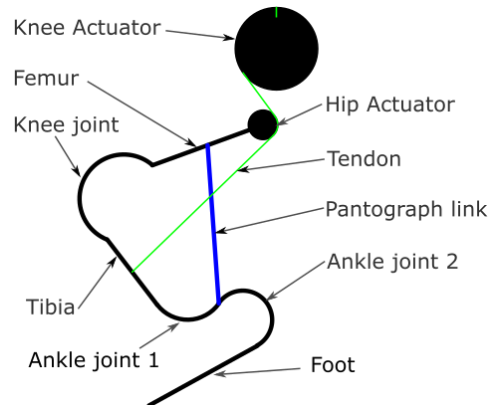

Figure 4 Schematic view of the robot's hindleg.

The originally designed step-cycle, which was introduced in [1], could be kept by maintaining the pantograph configuration of the leg. The leg step-cycle with the new leg configuration can be seen in Figure 5. The first position (1) depicts the leg in the beginning of the stance phase with the foot on the ground; (2) shows the leg at the end of the stance phase with the leg at its furthest backward position; (3) is after lift-off and during the swing phase of the leg; (4) is at the end of the swing phase just before touching down again. The leg is under-actuated with two actuators directly controlling the rotation of the hip and the flexing of the knee. Additionally, there are two ankle joints: one is actuated with the knee through a pantograph mechanism and the other is a flexible hinge joint that allows the foot to flex according the weight on the leg. The pantograph principle, which was adapted for this design, allows for a passive actuation of the ankle together with the knee joint. This is achieved by implementing a link with fixed length between the femur and the ankle of the leg(see pantograph link in Figure 4).

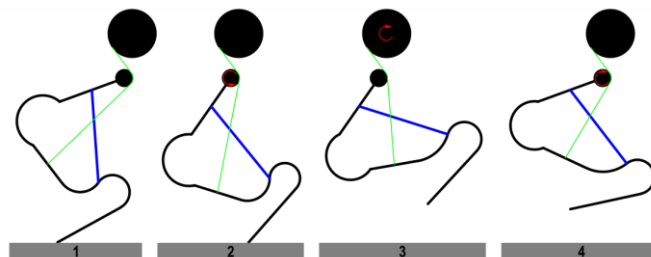

Figure 5 The revised step cycle for the robot with the respective actuation indicated by the red arrows.

The resulting final design of the hindleg can be seen in Figure 6. All grey parts are 3D printed using the Selective Laser Sintering (SLS) process. SLS was chosen over Fused Deposition Modeling (FDM) as the typical materials used in the latter (e.g. acrylonitrile-butadiene-styrene, polylactic acid) are typically too brittle to provide the mechanical compliance that was sought after. Instead the chosen SLS process made it possible to produce Nylon parts that can undergo more substantial deformations in the elastic domain repeatedly without breaking.

The two servo motors to actuate the leg are fixed within the hip, which can be attached to the body of the robot. The leg itself consists of the main leg part, the link as previously described, a servo horn, which simplifies attachment to the servo motor, a tendon, a PCB with a knee position sensor as well as a pressure sensor on the foot. The previously described link, for the pantograph mechanism can be "clipped" into two hinge joints without using any screws or tools. The tendon made from Nylon wire is attached by screws to the leg at the tibia on one side and to the coil on the other. Coil and leg are designed in such a way that the chance of the tendon slipping off the coil is minimized. Additionally, the tendon runs through holes on the leg and on the link. The knee sensor is a Hall sensor, which measures the position of a magnet opposite to the PCB. A resistive pressure sensor (not depicted in Figure 6) is attached to the sole of the foot.

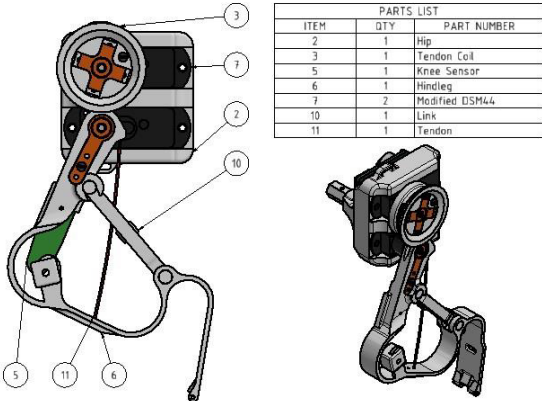

Figure 6 Technical illustration of the left hindleg module with all major components labelled.

As shown in [1], the foreleg does not require a pantograph leg design. This allows for a simpler leg consisting of the same parts as the hindleg, minus the link. The resulting foreleg assembly can be seen in Figure 7. One flexible elbow joint is sufficient when used with a slightly bent foot, which dampens the impact on the leg. The elbow joint sensor is identical to the knee sensor described above.

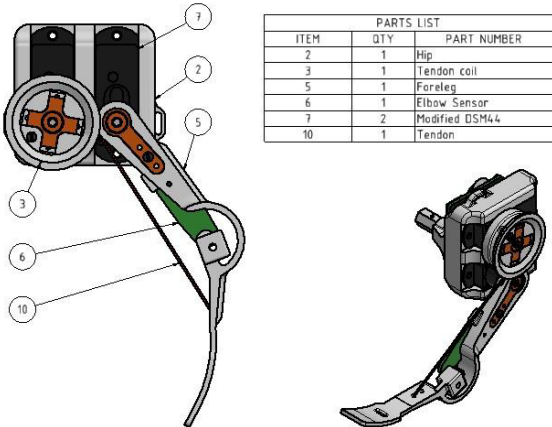

Figure 7 technical illustration of the left foreleg module with labelled main components.

C. Power Features

In order to get as much usage time from the robot as possible, a 2-cell LiPo battery with 1000 mAh is used allowing for approximately half an hour of walking. To additionally boost the usage time, the robot's batteries can be charged using a standard Qi wireless charging pad, as used for state-of-the-art smartphones. For optimal use, the charging coil has been placed at the "belly" of the robot (see Figure 8), so it can be charged by simply placing the robot on a charging pad without any disassembly. The robot stays functional during charging, so walking on a larger wireless charging coil would be possible.

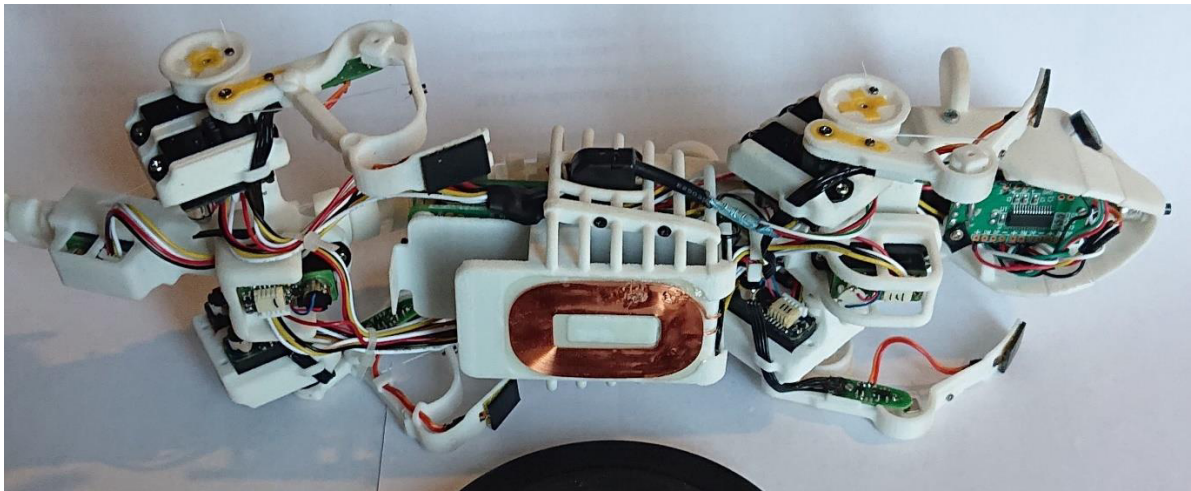

Figure 8 Wireless charging coil, in the "belly" of the robot.

This latest version also boasts several new power management features. First, multiple power regulators are used, with one each for the Raspberry Pi computer, the Spine adapter and three separated regulators for the motor groups (left/ right legs and body), in order to minimise power fluctuations. The battery state is monitored for both LiPo cells as well, to warn in case of low power or cell imbalance. All motors are capable of monitoring their supply voltage as well.

D. Comparison to earlier versions

Table II shows the previous releases of NeRmo. Over the last two years, the number of degrees of freedom (DOF) was increased from a basic quadruped robot with 8 DOF, to a robot with actuated spine and tail (10 DOF), to a more complex robot with a two-DOF spine and a two-DOF head. Additionally, the control hardware was improved after the discontinuation of the Intel® Edison from simple microcontrollers to a Raspberry Pi running the Raspian Operating System. The increased cost is due to the custom PCB added to the servos, as well as the position and force sensors added.

Table 2: Successive robot versions developed during the course of the project. For reference, *Rattus Norvegicus* is 370-440 mm long and weighs between 250 and 400 g.

| | Build | DOF | Sensors | Cost | OS | Processor |
|------|----------|-----|---------|------|---------|---------------------|
| V1 | May 2017 | 8 | 1 | 480 | Linux | Intel® Edison |
| V2 | Apr 2018 | 10 | 4 | 400 | N.A. | Teensy 3.6 |
| V2.1 | Mai 2018 | 10 | 0 | 350 | N.A.. | Teensy 3.1 |
| V3 | Oct 2018 | 11 | 4 | 400 | N.A. | Teensy 3.1 |
| V4 | Apr 2019 | 13 | 13 | 1000 | Raspian | Raspberry Pi Zero W |
| V4.1 | Jan 2020 | 13 | 13 | 1000 | Raspian | Raspberry Pi Zero W |

III. DIGITAL TWIN

The construction files for this robot were also used to create a digital twin at the Neurorobotics Platform (NRP). The workflow to create a simulation model from the available CAD design files is shown in the following graph:



The original model was created using Autodesk® Inventor®. This model had to be transferred to Autodesk® Fusion360® for which an exporting script allows for the generation of a simulation-capable model. This model then could then be fully defined using the Blender Robot Designer, which was also created as part of the Neurorobotics Platform. After complete definition of the physical properties, actuator and sensors, the robot was imported into the Neurorobotics Platform

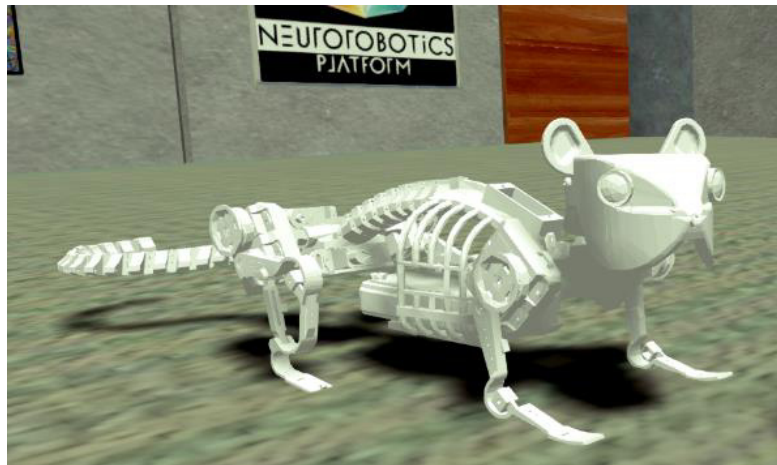

Figure 9 Simulated NeRmo model in the NRP.

The simulation model, shown in Figure 9, enables the users to implement simulation of the robot's movements before execution on the physical system; this opens up many possibilities in terms of virtual prototyping and decreases the risk of damage to the physical system. This model was simplified from the original CAD drawings by combining non-moving parts, like the electronics frame and the body frame or the head with all its components, together. This approach combined with the reduction of the number of the vertices of the model in the robot designer enables achieving a fast and efficient simulation.

The digital twin will be part of release 3.0 of the NRP and as such freely accessible to all NRP users. Furthermore, should users need to modify any parameter of the model, all design files are freely accessible at: https://github.com/Luchta/nermo_simulation.

IV. CONCLUSION AND OUTLOOK

Released at the end of a two-year development process, the latest version of NeRmo was an exercise in finding the right balance between functionalities, ease of assembly and price. It is the most capable robot since the start of the project and also the most robust. The variety of embedded sensors coupled to the embedded compute power make it an attractive research platform.

Future works will focus on the use of the robot in motion control studies and, most importantly, in exploring the reality gap between simulation and reality by training the digital twin on the NRP and transferring the resulting controllers onto the physical robot.

Despite the discontinuation of funding from the HBP for work on this robot in the next phase of the project, it is clear that NeRmo still has much to offer to the Neurobotics community. Future works could indeed focus on the use of the robot in motion-control studies and, most importantly, in exploring the reality gap between simulation and reality by training the digital twin on the NRP and transferring the resulting controllers onto the physical robot.

ACKNOWLEDGMENTS

We would like to thank Benedikt Feldotto for his help in creating the simulated version of NeRmo. The research leading to these results has received funding from the European Union Horizon 2020 program under grant agreement No. 785907 (Human Brain Project SGA2)

REFERENCES

- [1] P. Lucas and A. K. Florian Walter, "Design of a biomimetic rodent robot," Technische Universitaet Muenchen, Institut fuer Informatik, Tech. Rep. TUMI1873, 2018.
- [2] P. Lucas, S. Oota, J. Conradt, and A. Knoll, "Development of the neurobotic mouse," in Proceedings IEEE International Conference on Cyborgs and Bionic Systems, Munich, Germany, 2019, p. 6.

Appendix

A Datasheet of NeRmo, to be used as standalone description for dissemination and communication purposes.

Neurorobotic Mouse (NeRmo) V4.1

- **Quadruped Bio-mimetic Robot**
- **Tendon driven**
- **Easy to control via WIFI**
- **Short Assembly Time**
- **Modular**
- **Open Source**

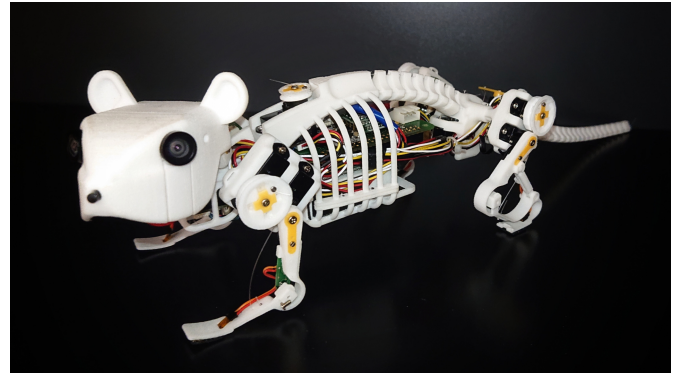

Introduction

The NRP Mouse is a Biomimetic robot, which mimics the appearance and motion of a common Rodent, the rat. The version 4.1 of the NRP Mouse family is a slight rework of version 4, streamlining the design to improve the handling and assembly of the different parts, while guaranteeing durability. As the previous version it is build to serve as a research platform that can be used within and outside of the HBP. New additions include a complete customized electronics setup, allowing for a full motor control, a fully articulated head carrying two wide angle cameras and a new leg design, which is sturdier and simpler to produce than previous designs, while providing a almost equal range of motion.

Physical Characteristics

| | |
|-----------------------|-----------------|
| Length | 405 mm |
| Length Scapula-pelvis | 117 mm |
| Height | 91 mm |
| Width | 90 mm |
| Weight | 275 g |
| Material | PA12, Polyamide |

Motion

| | |
|--------------------|---------------------------------|
| Degrees of Freedom | 13 |
| each Leg | 2 Hip Rotation and Knee flexion |
| Spine | 2 Lateral and Lumbar flexion |
| Tail | 1 Lateral flexion |
| Head | 2 Pan and Tilt |
| Speed | ≈ 0,3 m/s |

Control

With a Raspberry Pi as base computing platform, all gait generation can be done on the robot using either C++ or Python.

Project

This Robot was created by Peer Lucas (TUM) and Prof. Dr. Jörg Conradt (KTH) as part of the Neurorobotics Platform of the Human Brain project.

Contact: peer.lucas@tum.de

Web: www.neurorobotics.net

The research leading to these results has received funding from the European Union Horizon 2020 Programme under grant agreement No. 785907 (Human Brain Project SGA2)

A C++ Library allowing for control of the Robot will be made available. A simple ROS distribution is available for Raspberry Pi as well, allowing for Robot control via a Remote Roscore Host.

Power

| | |
|----------------|-----------------------------|
| Battery | 7,4 V 1000 mAh LiPo |
| On Board Power | 3,3V; 5,0V; 6,0V |
| Run Time | ≈ 25 min continuous walking |

Actuators

Power HD - DSM44 Servos with custom electronics including hall sensors for contactless rotation measurement and current sensing.

Sensors

| | |
|-----------|---|
| Actuators | Every actuator can provide position and current |
| Legs | Knee Angle |
| Feet | Ground Pressure |
| Head | Two wide Angle HD Cameras Nose collision switch Inductive Head switch |

Processing Power

| | |
|-------------------------|---------------------|
| Main Computer (Brain) | Raspberry PI Zero W |
| Motor Interface (Spine) | STM32F777VIT6 |
| Motor Controllers | STM32L031G6U6 |

Material Cost

| | |
|----------------|---------|
| Hardware Robot | ≈1000 € |
|----------------|---------|

Specifics

Cameras - U1-MWD

| | |
|------------------|------------------|
| Sensor | 1/4 |
| Resolution | 1280 x 720 Pixel |
| Pixel | 720 1. OMP |
| Minimal Lighting | 0,5 LUX |
| S/N Ratio | ≥ 48 dB |
| Gamma | 0,45 |
| Shutter | 30 fps |
| White balance | automatic |
| Lens | 1,8 mm 150 ° |
| Temp | -10 to +50 deg |
| Energy | 80 mA |

Base Servos - PowerHD DSM44

| | |
|-------------------|--------------------------------|
| Modulation: | Digital |
| Torque: | 6.0V: 22.22 oz-in (1.60 kg-cm) |
| Speed: | 6.0V: 0.07 sec/60° (1,2 ms/1°) |
| Weight: | 0.20 oz (5.8 g) |
| Dimensions: | 22x8,7x22 (LxWxH) |
| Motor Type: | Coreless |
| Gear Type: | Metal |
| Rotation/Support: | Single Bearing |
| Rotational Range: | 60° |
| Connector Type: | J |
| Pulse Range: | ≈ 700 - 2300 μs |

Raspberry Pi Zero W (Brain)

| | |
|-------------|--|
| Dimensions: | 65mm x 30 mm x 5 mm |
| SoC: | Broadcom BCM2835 |
| CPU: | ARM11 running at 1GHz |
| RAM: | 512MB |
| Wireless: | 2.4GHz 802.11n wireless LAN |
| Bluetooth: | Bluetooth Classic 4.1 and Bluetooth LE |
| Power: | 5V |
| Storage: | MicroSD card |
| Output: | Micro USB |
| GPIO: | 40-pin GPIO |

Custom Servo PCBs

| | |
|---------------------|---|
| Microcontroller: | STM32L031G6U6 |
| Motor Voltage: | 6V |
| Logic Voltage: | 3.0V |
| Connectivity: | UART, I2C |
| Protocol | Singel Wire UART |
| Measurements | Motor Position Motor Current Supply Voltage |
| Position Sensor: | contactless (Hall Sensor) via Extension PCB |
| Additional Sensors: | - Knee Angle - Foot Pressure |

Raspberry Pi Adapter (Spine)

| | |
|-------------------|--|
| Dimensions: | 65mm x 30 mm x 19 mm |
| Microcontroller: | STM32F777VIT6 |
| Sensors: | Battery Voltage Battery Balance 9DOF IMU |
| External Sensors: | Nose Button, Head Padding |
| Power Management: | 1x 3,3 V 1 A 1x 5,0 V 1 A 3x 6,0 V 1 A |
| Charging: | QI Wireless Charger (max 1A) |
| Power: | 5V, supplied via micro USB connector |
| indicators | Blue Led |