

## The new polarizer devices at RESEDA

**J. Repper<sup>1,2,\*</sup>, W. Häußler<sup>1</sup>, A. Ostermann<sup>1</sup>, L. Kredler<sup>1,2</sup>, A. Chacón<sup>2</sup> and P. Böni<sup>2</sup>**

<sup>1</sup> Forschungs-Neutronenquelle Heinz Maier-Leibnitz (FRM II), Lichtenbergstr. 1, 85748 Garching, Germany

<sup>2</sup> Lehrstuhl für Experimentalphysik E21, TU München, James-Franck-Str. 1, 85748 Garching, Germany

\* now at: Paul Scherrer Institut, Materials Science and Simulation, NUM/ASQ, 5232 Villigen PSI, Switzerland

E-mail: [julia.repper@psi.ch](mailto:julia.repper@psi.ch)

**Abstract.** In the neutron resonance spin echo method the information about sample dynamics is encoded in the neutron beam polarization measured in the analyzer-detector unit. Thus, the method is not applicable for sample systems and environments, which depolarize the neutron beam strongly. To overcome this drawback a neutron analyzer directly before the sample position may be installed to perform MIEZE-I experiments. We compared the performance of a transmission polarizer and a solid-state bender at this position for the neutron resonance spin echo spectrometer RESEDA by Monte Carlo simulations. It turned out, that the polarization as well as the intensity transmitted to the sample position is more advantageous for the transmission polarizer as for the bender. In addition, we present measurements of the polarization and intensity performance of the transmission polarizer already installed at RESEDA to polarize the neutron beam coming from the reactor FRM II. The measurements are in good agreement with Monte Carlo simulations.

### 1. Introduction

Neutron spin echo (NSE) is a well known method to measure dynamics with high energy resolution [1]. Based on NSE several neutron resonance spin echo (NRSE) instruments were developed in the last decades [2, 3, 4]. At the neutron resonance spin echo spectrometer RESEDA at FRM II, studies on magnetic fluctuations in ferro- and helimagnetic compounds and on the diffusion of water and hydrogen in porous samples were performed up to now [5]. In NSE and NRSE, the energy resolution is decoupled from the wavelength spread of the primary neutron beam. Thus, NRSE and NSE can provide high primary intensities, combined with a high momentum and energy resolution required for studies of relatively slow dynamics. The information about the dynamics in the sample is encoded in the beam polarization, which is determined by the analyzer-detector unit.

As the beam polarization is the measured quantity the NSE and NRSE techniques suffer from a serious drawback: the beam polarization for spin-incoherent scattering systems, i.e. hydrogen containing materials, is limited to 1/3, so that the statistical accuracy of these measurements is decreased. Moreover, measurements in ferro magnetic materials are not possible due to the depolarization of the beam by the magnetic domains. The MIEZE-I technique, a variant of the NRSE method, measures the intermediate scattering function independently of

the beam polarization. Thus, the depolarization neither due to the sample nor due to the sample environment does affect the measurement. The MIEZE-I unit consists of a polarizer, two radio-frequency spin flipper coils (NRSE coils) and an additional analyzer. All components are located before the sample position. At the detector, the neutron beam may be unpolarized and the oscillating amplitude of the intensity yields the information about the sample dynamics. A comprehensive introduction to MIEZE-I is given e.g by Keller et al. in [6] and in a recent realization by Georgii et al. [7]. The MIEZE-I unit is well suited as an additional option for the NRSE instrument RESEDA as the polarizer as well as the NRSE devices are already installed, and only an additional spin analyzer in front of the sample is needed.

In this paper, we compare the results of Monte Carlo simulations for the performance of RESEDA equipped with a solid-state bender and a transmission polarizer (V-cavity), both located behind the NRSE devices, directly in front of the sample position. In addition, the experimentally observed performance of the V-cavity, which is installed in front of the NRSE devices is compared with Monte Carlo simulations.

## 2. Polarization devices

*Polarizer in front of NRSE devices* The transmission polarizer, a single V-cavity (Mezei, 1988), between the reactor and the first NRSE devices has an entrance window of  $36.6 \times 36.6 \text{ mm}^2$  and a length of 2 m. The wafers for the V are coated with Fe-Si supermirrors  $m = 3$  and the outer walls of the neutron guide consist of glass plates coated with Ni-Ti layers with  $m=1.2$ . The cavity is installed at RESEDA since 2006.

*Polarizer behind NRSE devices* The simulated solid-state bender consists of a stack of 270 silicon wafers. The wafer thickness is 0.15 mm. Each wafer is coated with Fe-Si supermirrors  $m = 3$  at both sides. The wafers are bent with a radius of 0.50 m, leading to a critical wavelength of  $\lambda^* \approx 2.3 \text{ \AA}$ . The neutron entrance window of the bender has dimensions of  $40 \times 40 \text{ mm}^2$  and the length of the bender is 50 mm. As the bender emits the spin up and spin down neutrons within different angles relative to the incident beam direction a collimator with a length of 30 mm has to be used to absorb the spin down component.

The simulated transmission polarizer consists of five V-cavities, which are arranged in parallel channels vertical and perpendicular to the beam direction. The silicon wafers used to build the Vs have a thickness of 0.3 mm each and are coated with Fe-Si supermirrors to reach an  $m$ -value of 4. The cavity has a length of 260 mm and in total a neutron entrance window of  $40 \times 40 \text{ mm}^2$ .

## 3. Experimental details

### 3.1. Measurements

The set up to determine the polarization performance of the V-cavity in front of the NRSE devices consists of two spin flippers at a distance of 20 cm to each other and the first one 30 cm away from the exit of the cavity, a  $^3\text{He}$  cell for spin analysis and a CCD detector camera with a cross section of  $65 \times 96 \text{ mm}^2$ , which is located 100 cm behind the second spin flipper (compare figure 1). To avoid depolarization between the cavity and the analyzer appropriate guide fields were installed. Four measurement steps are necessary to determine the spin flip efficiency of the flippers and the polarization of the neutron beam after passing through the polarizer, the analyzer and the guide fields. At first, the spin flippers are switched off, and the neutron beam polarization is given by the transmission polarizer. In the second step, one of the spin flippers is switched on, the other remains switched off, and in the third step vice versa. Finally, the two spin flippers are operated simultaneously. Here, the analyzer efficiency and the guide field efficiency is assumed to be 100 %. For the measurements a wavelength of  $\lambda = 5.3 \text{ \AA}$  was chosen. A slit of  $33 \times 33 \text{ mm}^2$  was positioned behind the exit of the V-cavity to avoid the detection of neutrons, which did not pass the cavity.

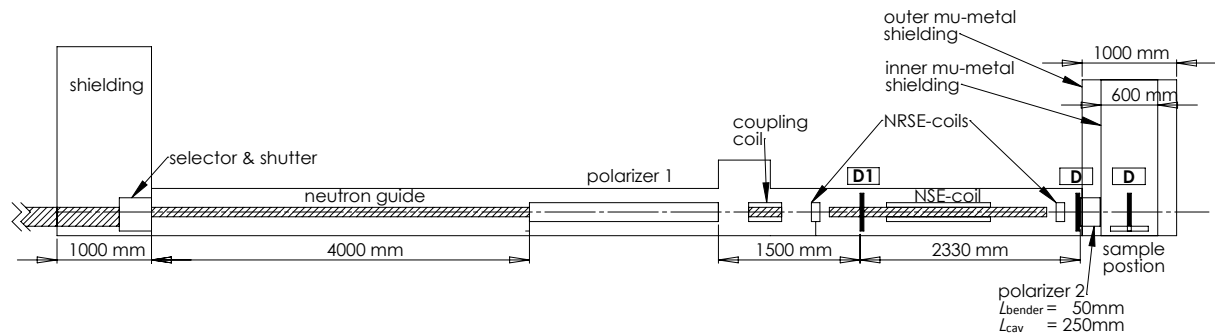

**Figure 1.** Schematic view of the neutron resonance spin echo instrument RESEDA as used for the McStas simulations presented. The detector D1 has dimension of  $65 \times 96 \text{ mm}^2$  and was used for gaining data for the simulation of the transmission polarizer in front of the NRSE devices. The detectors D have cross sections of  $40 \times 40 \text{ mm}^2$  and were used for the simulation of the polarizer devices behind the NRSE devices. This second polarizer is either a solid state bender (bender) or a V-cavity (cavity).

### 3.2. Monte Carlo simulations

All Monte Carlo simulations were performed using McStas [8]. Here, self-written components were used to simulate the polarization devices. Figure 1 shows a schematic view of the neutron resonance spin echo spectrometer RESEDA as used for the simulations.

*Polarizer in front of NRSE devices* A position sensitive detector (PSD) with a detector area of  $65 \times 96 \text{ mm}^2$  was located 150 cm behind the end of the V-cavity. A slit of  $33 \times 33 \text{ mm}^2$  was positioned directly behind the V-cavity. To simulate the neutron background, detected during the experiment, an uniform counting rate of 0.2 Hz/pixel was added to the intensities simulated. The polarization  $P$  was determined by using  $P = (I_{\text{up}} - I_{\text{down}})/(I_{\text{up}} + I_{\text{down}})$ , where  $I_{\text{up}}$  and  $I_{\text{down}}$  give the intensity of the spin up and spin down neutrons as measured in the PSD detector D1 (figure 1).

*Polarizer behind NRSE devices* The polarizers behind the NRSE devices were simulated with an unpolarized incident neutron beam, as e.g. in MIEZE the beam may become depolarized by the NRSE coils. Therefore, the transmission polarizer in front of the NRSE devices was replaced in the simulations by a neutron guide with equal dimensions with a coating of  $m = 2$ . The wavelength distribution in the incident neutron beam was chosen to 1 to 13 Å. The used detectors had cross sections of  $40 \times 40 \text{ mm}^2$  and were positioned directly in front of the second polarizer and at the sample position (figure 1). We used these two detectors (D in figure 1) to calculate the transmission of the beam through the polarizer device. The polarization  $P$  was determined by using  $P = (I_{\text{up}} - I_{\text{down}})/(I_{\text{up}} + I_{\text{down}})$  as measured in the detectors D.

## 4. Results

*Polarizer in front of NRSE devices* Figures 2 and 3 show the intensity distribution and the polarization distribution over the  $65 \times 96 \text{ mm}^2$  position sensitive detector area at a distance of 150 cm from the exit of the polarizer. In both figures the experimentally determined data are compared to simulated ones.

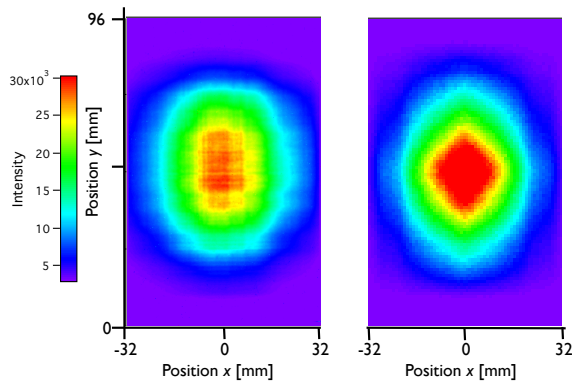

**Figure 2.** Intensity distribution over the PSD detector D1 (compare figure 1) as experimentally determined by a measurement (left) and simulated by Monte Carlo simulations (right).

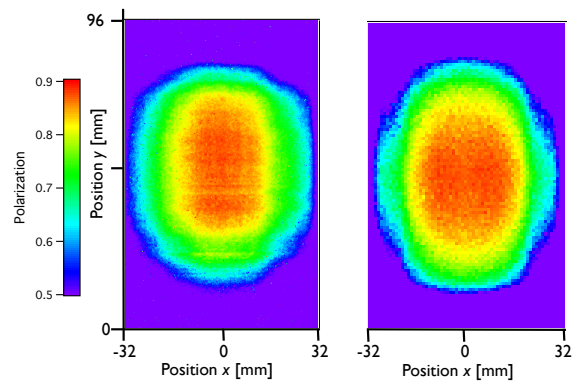

**Figure 3.** Polarization distribution over the PSD detector D1 (compare figure 1) as experimentally determined by a measurement (left) and simulated by Monte Carlo simulations (right).

*Polarizer behind NRSE devices* Figure 4 compares the polarizations of the neutron beam caused by the solid-state bender and the V-cavity in dependence of the wavelength. For both detectors with cross sections of  $40 \times 40 \text{ mm}^2$  at the sample position were used. The figure of merit  $T^* = T \cdot P^2$  of the solid-state bender ( $T_{\text{bender}}^*$ ) and of the V-cavity ( $T_{\text{cavity}}^*$ ) at the sample position is shown in figure 5 as determined by detectors with an area of  $40 \times 40 \text{ mm}^2$ .

## 5. Discussion

*Polarizer in front of NRSE devices* The shape of the neutron beam measured by the CCD camera shows a good agreement with the shape of the simulated neutron beam (figure 2). The observed intensity distribution over the cross section of the neutron beam is consistent with the distribution found in the McStas simulations. Slight differences are caused by mechanical imperfections of the polarizer itself as well as of the neutron guides, which guide the neutron beam from the reactor tank to RESEDA. The polarization distribution over the neutron beam as measured by the PSD detector is in good agreement with the compared simulation data (figure 3). The averaged polarization is 86 and 75% in the simulation compared to 84 and 72% in the measurement analyzed for detector areas of  $33 \times 33 \text{ mm}^2$  and of  $65 \times 96 \text{ mm}^2$ , respectively. The small deviations between the simulated and the measured values may arise from a non-perfect analyzer and guide field efficiency in the real experiment in contrast to the simulations, where the efficiencies are assumed to be 100%.

*Polarizer behind NRSE devices* The beam polarization directly behind the solid-state bender for a wavelength of  $3.8 \text{ \AA}$ , which is the minimum wavelength typically used at RESEDA, is 40 %, compared to 80 % behind the V-cavity. In contrast, the polarization of both devices is almost equal for the upper wavelength range used at RESEDA (around  $6 \text{ \AA}$ ). Whereas, the Bender causes beam polarizations of 94 %, the polarization with the V-cavity reaches 91 %.

In general, the figure of merit  $T^* = T \cdot P^2$  curve is larger for the cavity as for the bender. This reflects the large absorption of the neutron beam due to the 50 mm stack of silicon wafers in the bender. In contrast to the beam polarization  $P_{\text{bender}}$  the values of  $T_{\text{bender}}^*$  decrease for wavelengths larger than  $7 \text{ \AA}$ . This shows the even increasing neutron absorption effects with an increasing wavelength.

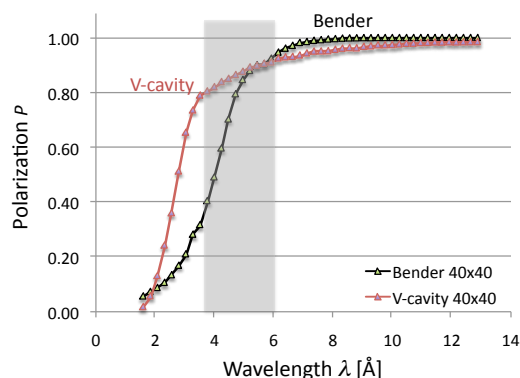

**Figure 4.** Polarization of the bender and the V-cavity both located behind the NRSE devices, measured with detectors with cross sections of  $40 \times 40 \text{ mm}^2$  positioned at the sample position. The highlighted area marks the wavelength range usually used at RESEDA (3.8 - 6 Å).

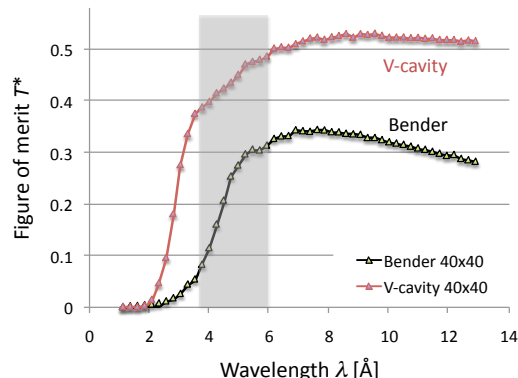

**Figure 5.** Figure of merit  $T^* = T * P^2$  of the bender and the V-cavity both located behind the NRSE devices, measured at the sample position. Detectors with cross sections of  $40 \times 40 \text{ mm}^2$  are used. The highlighted area marks the wavelength range usually used at RESEDA (3.8 - 6 Å).

## 6. Conclusion

We could show that the transmission V-cavity polarizer already installed at RESEDA delivers the performance, which was expected by Monte Carlo simulations with respect to intensity and polarization of the neutron beam. In addition, we decided, based on the here presented data to install an additional V-cavity, which consists of five parallel channels just before the sample position in order to use a MIEZE-I unit as optional instrument set up. This decision is based on the simulated polarization and intensity performance for the wavelength range needed. Also the given geometrical restrictions at RESEDA will allow us to use the cavity with a total length of 270 mm (including magnetic housing). However, in cases the space is more limited the performance of the solid state bender with its short length of only 90 mm is convincing.

## 7. References

- [1] F. Mezei: Neutron spin echo: A new concept in polarized thermal neutron techniques, *Z. Phys. A*, **255**(2), 1972, 146-160.
- [2] T. Keller; R. Gähler; H. Kunze; R. Golub: Features and performance of an NRSE spectrometer at BENSCH, *Neutron News*, **6**(3), 1995, 1-17.
- [3] M. Kitaguchi, M. Hino, Y. Kawabata, H. Hayashida, S. Tasaki, R. Maruyama, T. Ebisawa: Correction for beam divergence effect in a NRSE spectrometer with high resolution, *Meas. Sci. Technol.*, **19**, 2008, 034014.
- [4] M. Köppe, P. Hank, J. Wuttke, W. Petry, R. Gähler, R. Kahn: Performance and Future of a Neutron Resonance Spin Echo Spectrometer, *J. Neutron Res.*, **4**(1-4), 1996, 261-273.
- [5] W. Häußler, P. Böni, M. Klein, C. J. Schmidt, U. Schmidt, F. Groitl, and J. Kindervater: Detection of high frequency intensity oscillations at RESEDA using the CASCADE detector, *Rev. Sci. Instrum.*, **82**, 2011, 045101.
- [6] T. Keller, R. Golub, R. Gähler: Neutron spin echo - a technique for high-resolution neutron scattering, in: *Scattering and Inverse Scattering in Pure and Applied Science*, R. Pike and P. Sabatier (eds.), Academic Press, San Diego, 2002.
- [7] R. Georgii, G. Brandl, N. Arend, W. Häußler, A. Tischendorf, C. Pfeiderer, P. Böni, J. Lal: Turn-key module for neutron scattering with sub-micro-eV resolution, *Appl. Phys. Lett.*, **98**(7), 2011, 073505.
- [8] K. Lefmann and K. Nielsen: McStas, a General Software Package for Neutron Ray-tracing Simulations, *Neutron News*, **10**(3), 1999, 20-23.