

KIA4SM - Kooperative Integrationsarchitektur für zukünftige Smart Mobility Lösungen

Daniel Krefft, Sebastian Eckl, Uwe Baumgarten

Technische Universität München

Fakultät für Informatik

Lehrstuhl/Fachgebiet für Betriebssysteme

Günzburg, 02./03. März 2017

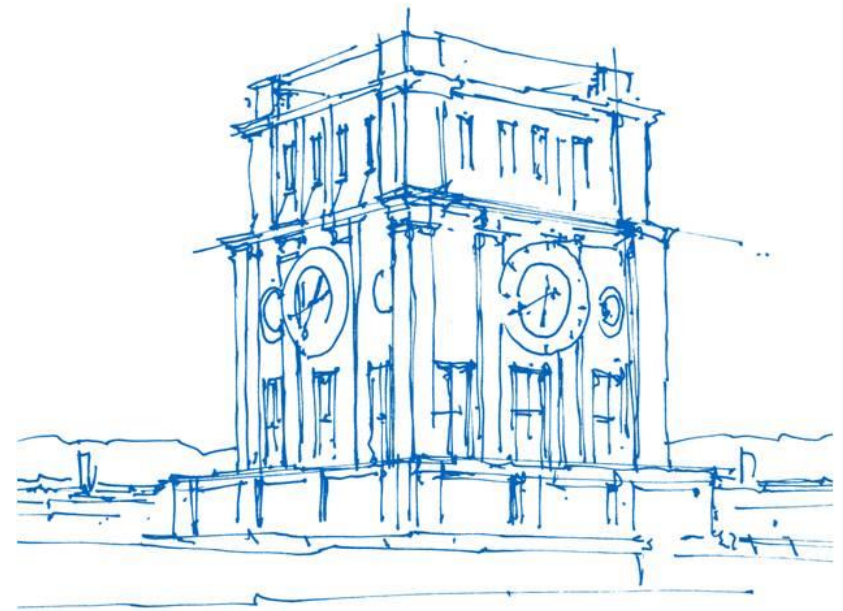

Uhrenturm der TUM

Agenda

- About
- Vision
- Project: KIA4SM
- Dynamic Reconfiguration
 - Migration
 - Partitioning
- Test Setup
- Next Steps

Agenda

- **About**
- Vision
- Project: KIA4SM
- Dynamic Reconfiguration
 - Migration
 - Partitioning
- Test Setup
- Next Steps

About

- Cyber-physical systems, their components, mechanisms, and algorithms
- Automotive systems both inside future and possibly inter-connected vehicles
- Microkernel for dynamic load on multi-core platforms



About



Sebastian Eckl, M.Sc.
Research Associate



Prof. Dr. Uwe Baumgarten
Head



Daniel Krefft, M.Sc.
Research Associate

Agenda

- About
- **Vision**
- Project: KIA4SM
- Dynamic Reconfiguration
 - Migration
 - Partitioning
- Test Setup
- Next Steps

Vision

- Research topic: Distributed, Embedded, Real-Time Systems
- Example: Automotive Systems
- (Future) Environment/Settings: C-ITS & Autonomous Driving
 - Increasing amount of data & SW-based functions
 - More powerful hardware
- Approach: HW-Consolidation & SW-Virtualization
- Challenge: Mixed-Criticality Systems

Vision

- Solution
 - State of Art: Static configuration
 - Goal: combination of partitioned dynamic and static parts
- Tradeoff: Flexibility vs. Reliability/Safety
- Idea: (Online) Dynamic Reconfiguration [Self-X]
 - Network (e.g. routing)
 - Hardware (e.g. FPGA)
 - Software (e.g. migration, replication)
- Choice: migration of SW-components at runtime

Agenda

- About
- Vision
- **Project: KIA4SM**
- Dynamic Reconfiguration
 - Migration
 - Partitioning
- Test Setup
- Next Steps

Project: KIA4SM

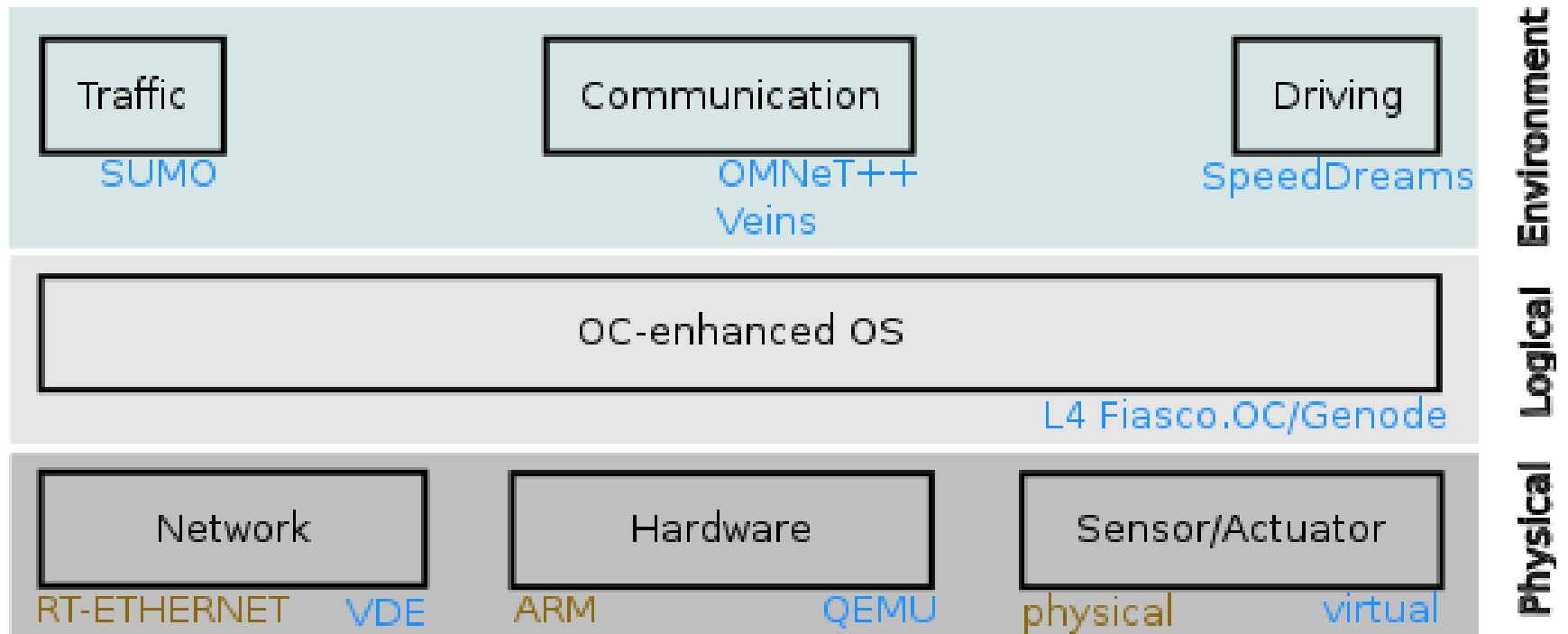

Three-layered architecture, driven by the idea of likewise combining virtuality and reality by allowing the execution of the OC-enhanced operating system on physical as well as virtual components.

Setup

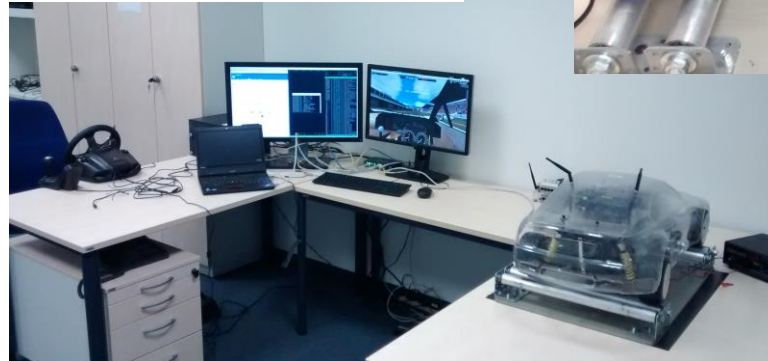
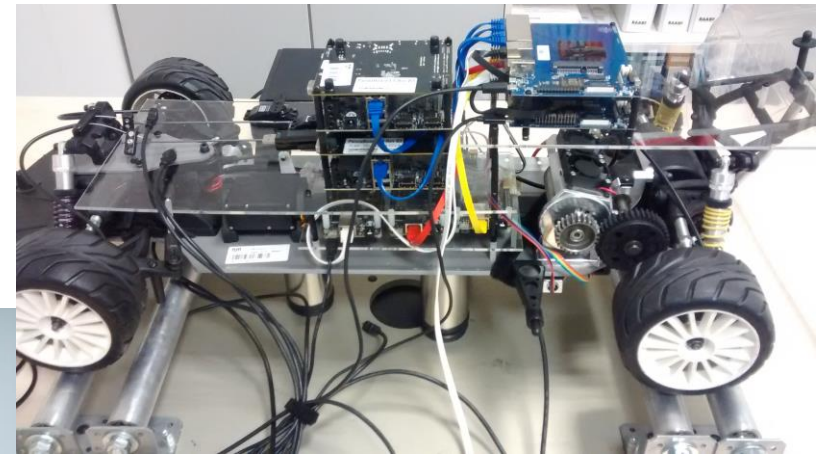

Hybrid Simulator Setup

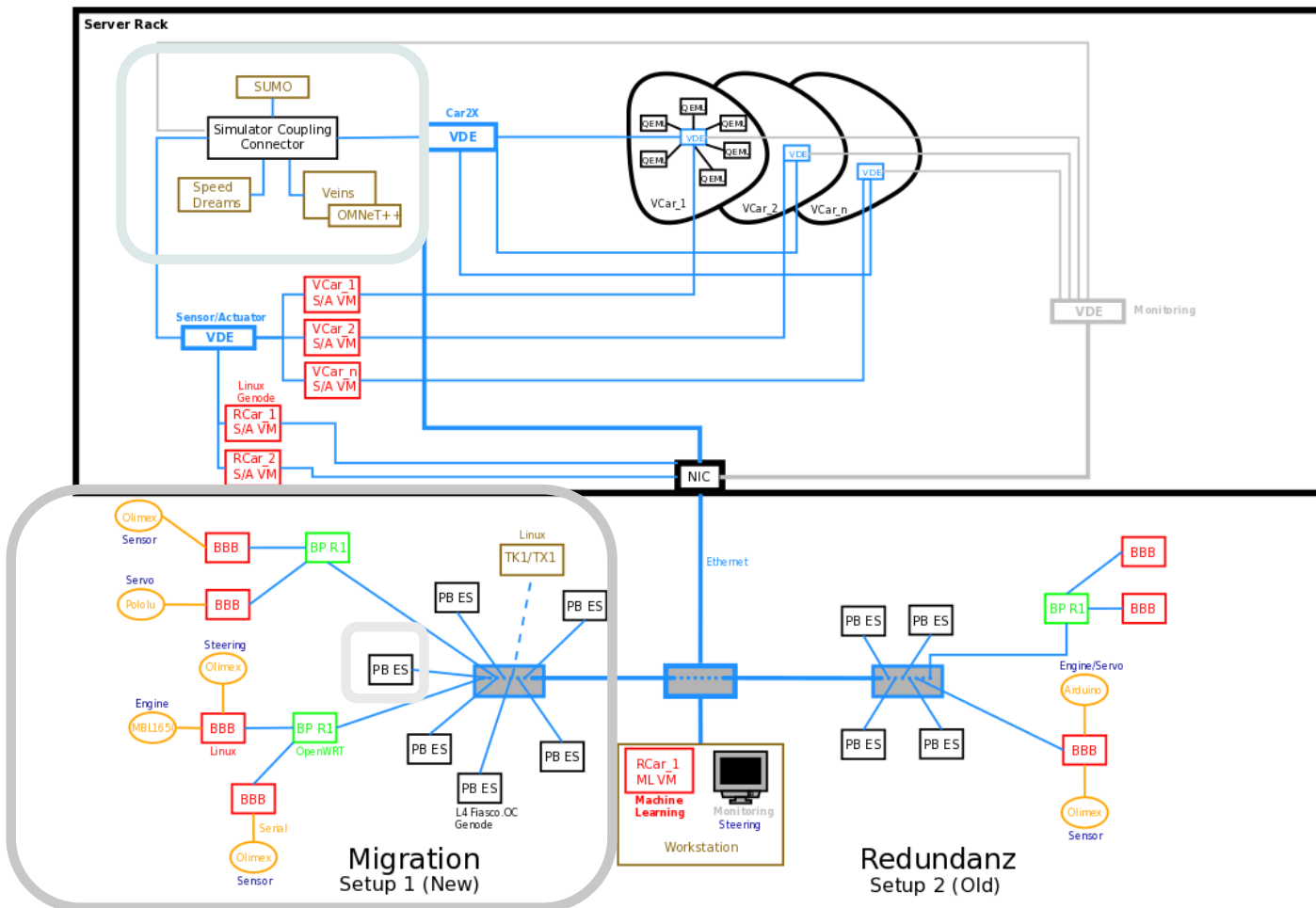

ECU in detail

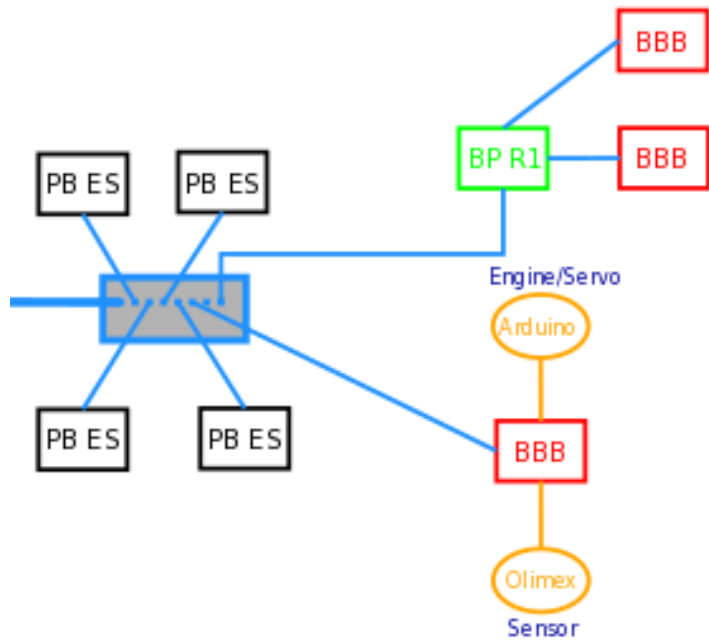

Background: Organic Computing (Flexibility)

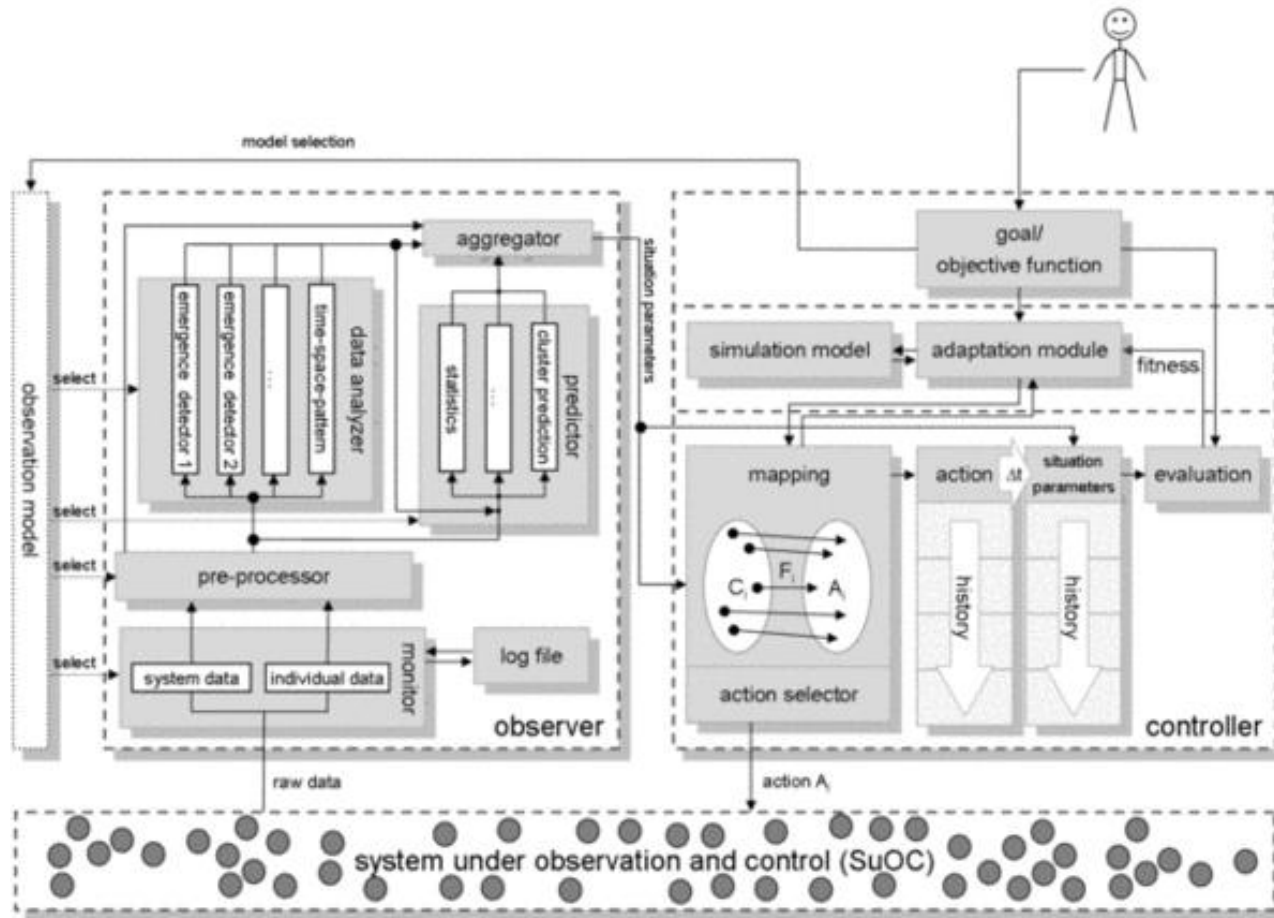

https://www.sra.uni-hannover.de/fileadmin/sra/pdf/Poster2005_QE_Mnif_v1.pdf

Background: Static deployment (Safety)

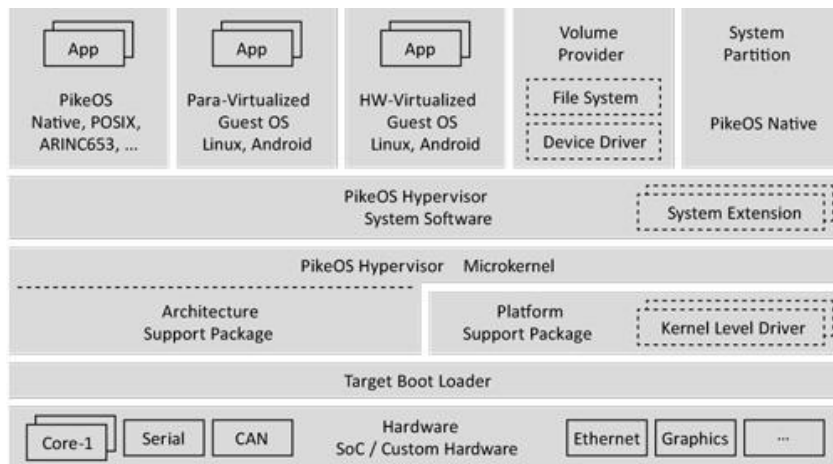

<http://www.opensynergy.com/produkte/pikeos/>

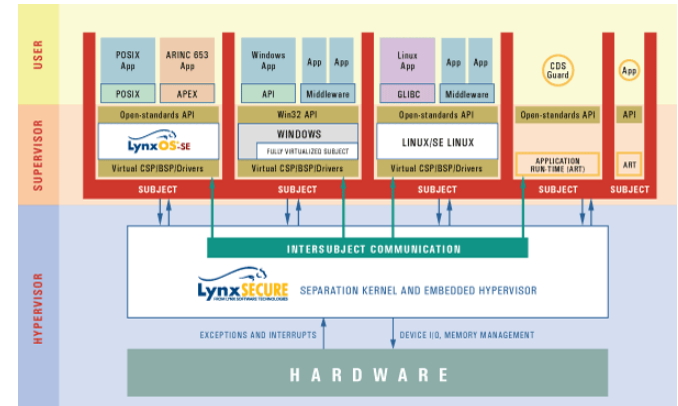

<http://www.lynx.com/wp-content/uploads/2008/02/lynxsecure-2009-600px.png>

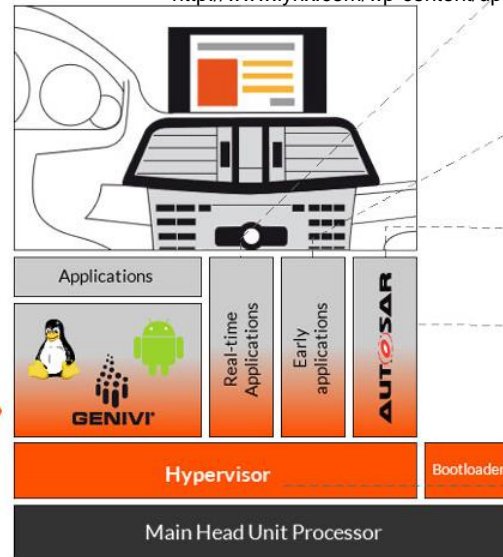

Das Produkt COQOS beinhaltet alle orangenen Module

<http://www.opensynergy.com/produkte/coqos/products/details>

Application in KIA4SM

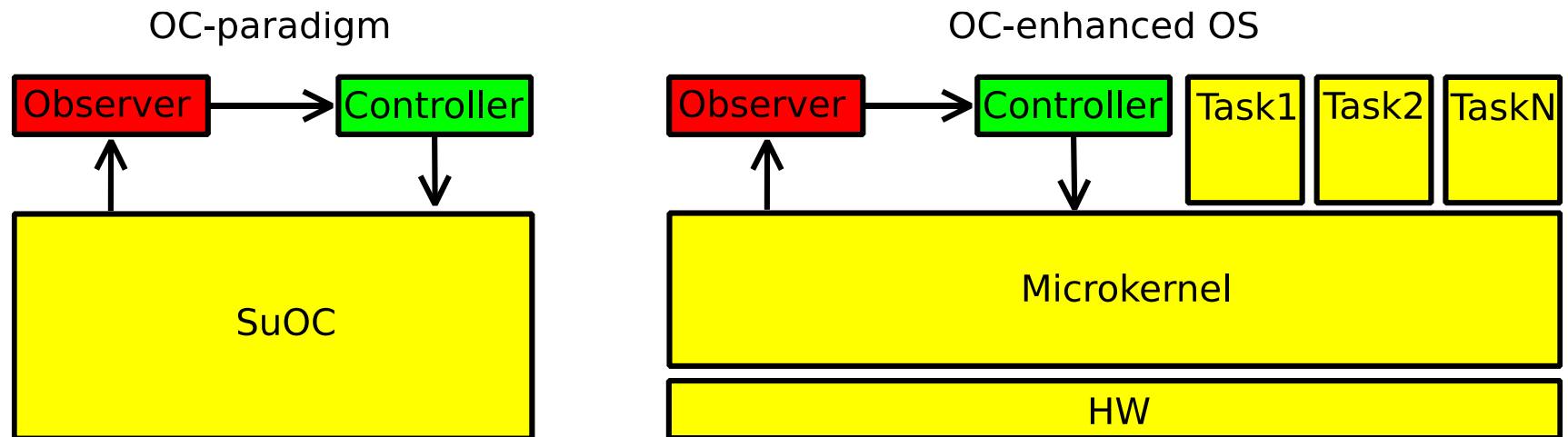

1. Organic Computing: Observer/Controller pattern
2. Small Trusted Computing Base (Microkernel)
3. Data Centric Communication: Publish/Subscribe mechanism

Research Areas

- Communication
- Migration
 - Checkpoint/Restore
 - Flexible Thread Management (variable task-set)
 - Admission
 - Synchronisation
 - Scheduling
 - Analysis/Planning (local/global)

Background: L4 Fiasco.OC & Genode

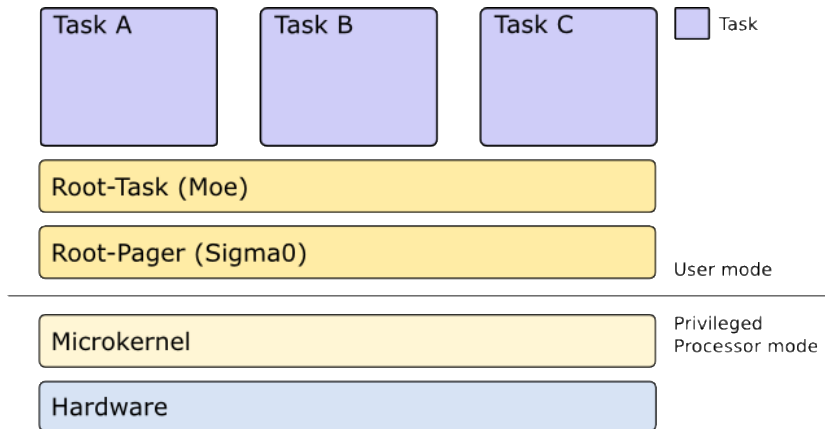

https://l4re.org/doc/l4re_intro.html

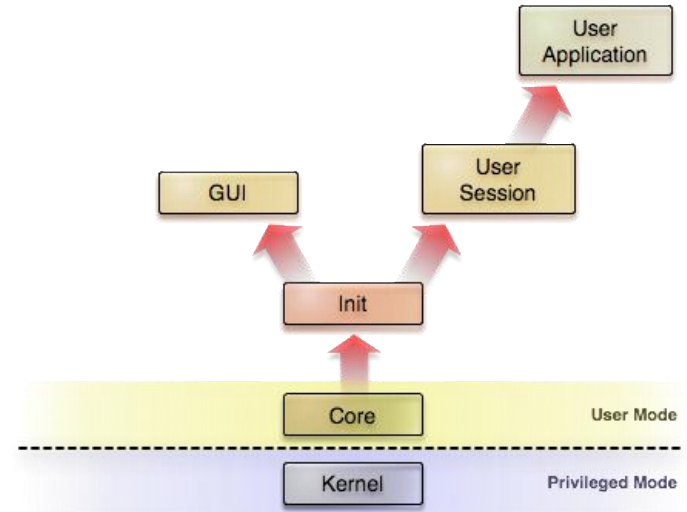

<http://genode.org/documentation/general-overview/index>

Hierarchical component structure

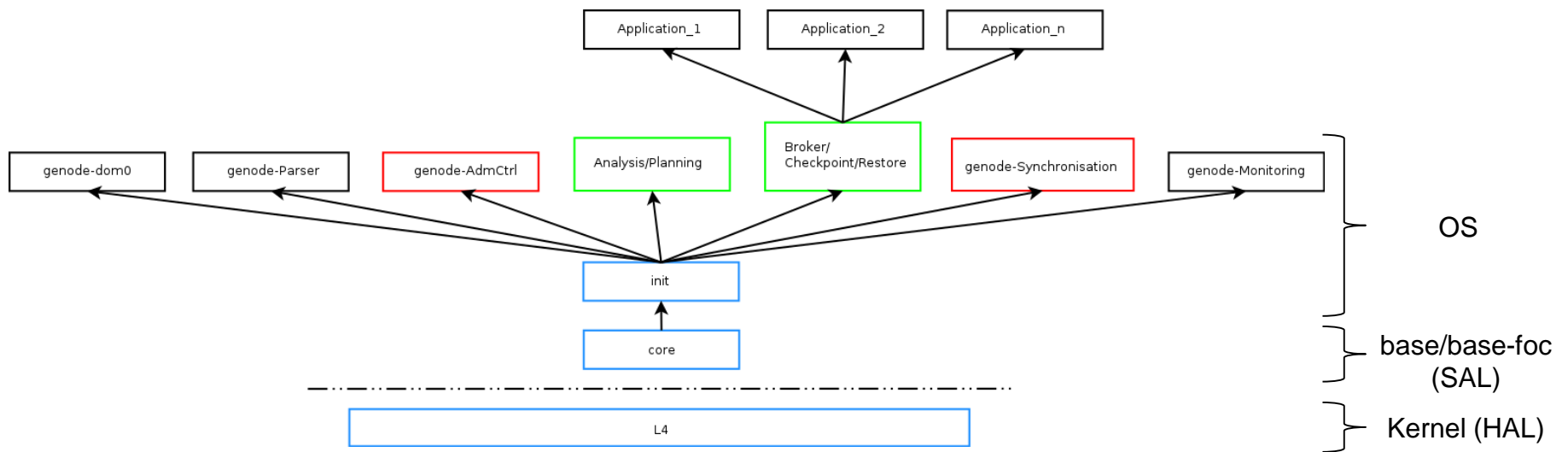

Agenda

- About
- Vision
- Project: KIA4SM
- Dynamic Reconfiguration
 - **Migration**
 - Checkpoint/Restore
 - Flexible Thread Management
 - Partitioning
- Test Setup
- Next Steps

Migration: OS components

- Core OS (migration execution)
 - **Snapshot (Checkpoint/Restore, De/Serialization)**
 - **(Real-Time) Scheduling**
 - Storage (tmpfs)
 - Networking (dom0)
 - (User-)Data exchange (Broker, Publish/Subscribe)
- Observer/Controller (migration planning)
 - Runtime Monitoring
 - Analysis/Planning (Machine Learning)
 - Synchronisation
- Working components
 - Sensors/Actuators
 - Processing (e.g. ACC)
 - Dummy (e.g. load producing applications)

Core OS – Checkpoint/Restore

- Granularity
 - Full snapshot (binary + mutual data)
 - Partial/Diff snapshot (mutual data)
 - Incremental (mutual data -> dump vs. single pages)
- Overhead/Resource consumption
 - Executed on demand: start/stop (user input, system event/interrupt)
 - **Executed after scheduler preempt**
 - Executed periodically/time-triggered (flag tasks/memory area)
 - Executed occasionally/randomly (flag tasks/memory area)
- Timing
 - **After interruption/termination of task/thread (result/data)**
 - After termination of single instruction within task/thread
 - At any point in time
 - ...

Core OS – Checkpoint/Restore

- (Non) Real-Time / (Non) Determinism
 - Separate Memory [Halt process + get access rights + copy memory]
 - **Shared Memory** [May halt process + copy memory changes]
 - Start/Stop
 - Copy-on-write
 - **Redundant Memory** [May halt process + no copy of memory]
 - Write into three different memory regions in parallel during runtime
 - No need to copy data

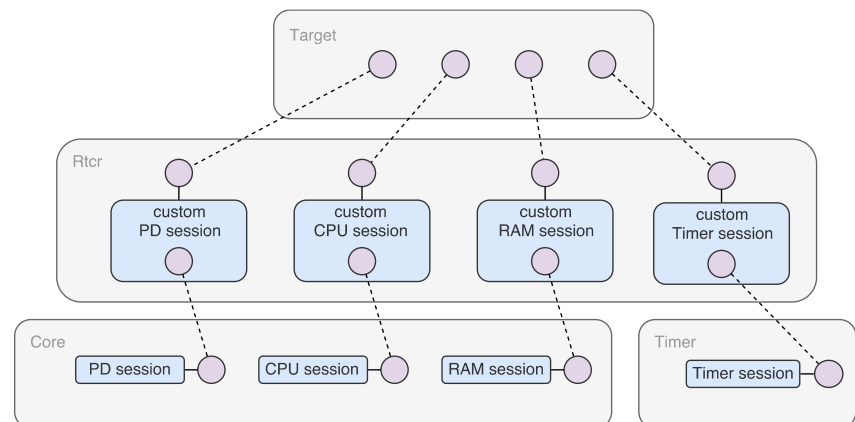

Core OS – Checkpoint/Restore

- HW-support
 - **Multi-Core** / Co-Processor
 - FPGA / dedicated HW (C/R in HW)
- Snapshot location
 - Storage at original ECU (transfer at runtime)
 - Storage at dedicated ECU/repository (transfer at runtime)
 - Storage decentralized at different ECUs (possible transfer at runtime)
 - **Storage at (potential) target ECU (pre-planned)**
- Implementation Layer (Kernel vs. **Userland**)

Core OS – Flexible Thread Management

- Load Situations (Migration, Overload)
 - Variable task sets
- Three Phases
 - Admission (local planning)
 - Synchronization (deployment)
 - Scheduling (enforcement)
- Combination of best-effort/real-time tasks (Mixed-criticality)
 - Information about criticality level (safety)
 - Thread and Cores accordingly classified

Core OS – Flexible Thread Management

- Admission
 - Aggregation of adaptation strategies (reactive & knowledge-based)
 - Local planning component
- Synchronization
 - Concept
 - Deployment of new system state without (hazardous) side effects
 - Keep the system up and running (on-line)
 - Implementation
 - Basic idea: synchronize in idle mode
 - Enhanced idea: synchronize by utilizing slack time
- Scheduling
 - Focus on standard scheduling policies
 - Simple implementation to keep up with the idea of TCB

Core OS – Flexible Thread Management

- Implementation Layer

Alternative	Kernel-Space	User-Space
1)	Scheduler	Logic
2)	Scheduler/Logic	-
3)	-	Scheduler/Logic

- Overhead & Resource consumption

Migration Process (global)

- Runtime Monitoring
- Migration Planning (Machine Learning)
 - Analysis
 - Planning
- Migration
 - Checkpointing (save all necessary process data)
 - Serialisation (prepare data for transport)
 - Transfer (send data to target platform)
 - De-Serialisation (unpack data on target platform)
 - Restore (restart process on target platform)
 - OPTIONAL: Reorganisation (restore communication paths)

Machine Learning

- Define different sorts of tasks (independent vs. dependent, dummy load, ...)
- Define necessary task attributes (deadline, WCET, criticality level, type of scheduler e.g. FP/RR or EDF)
- Build suitable task sets (e.g. same task type, combine varying task types, task order...)
- Goal
 - Offline: Identify possible connection between task attributes and resource mapping (schedulability analysis)
 - Online: Create migration decisions based on identified relationships

Agenda

- About
- Vision
- Project: KIA4SM
- Dynamic Reconfiguration
 - Migration
 - Checkpoint/Restore
 - Flexible Thread Management
 - **Partitioning**
- Test Setup
- Next Steps

Partitioning – Concept I

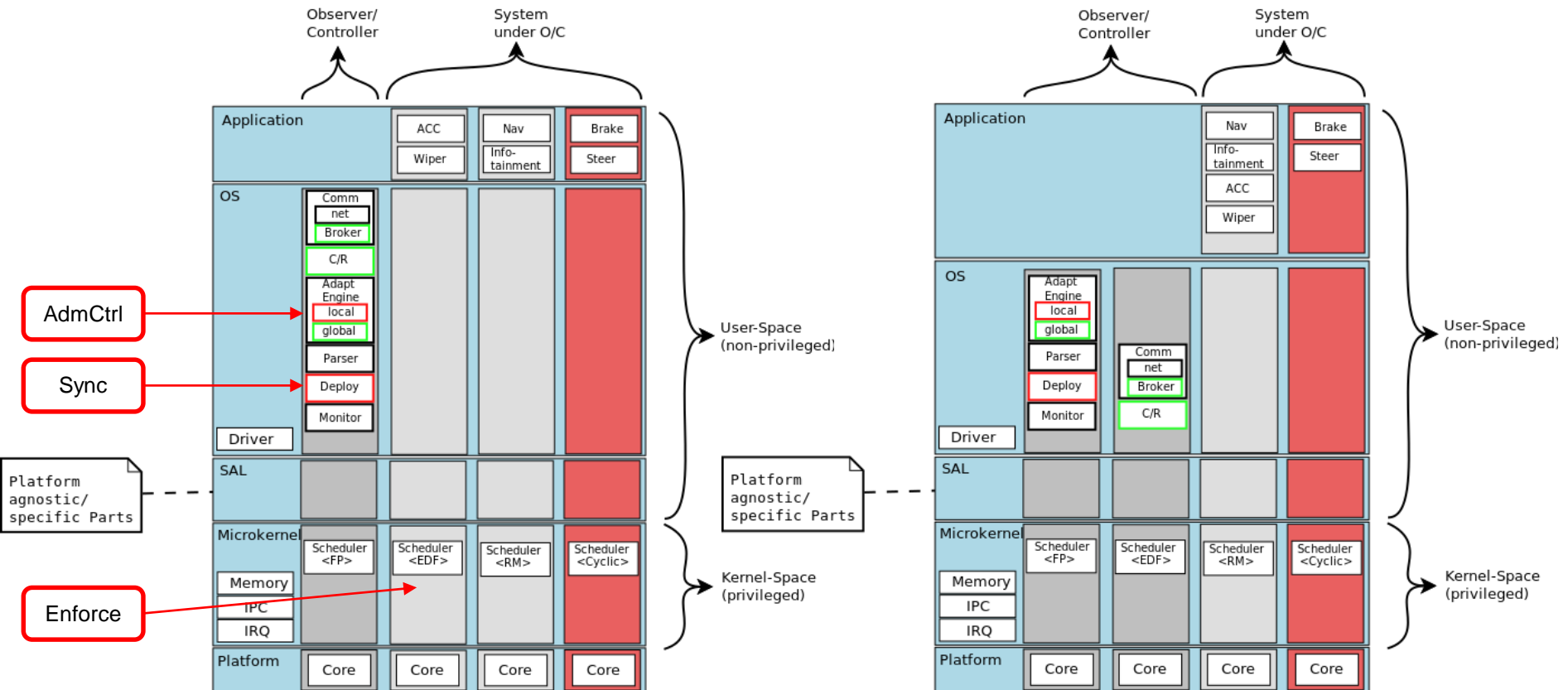

Combined management of best-effort, soft and hard real-time tasks.

Partitioning – Concept II

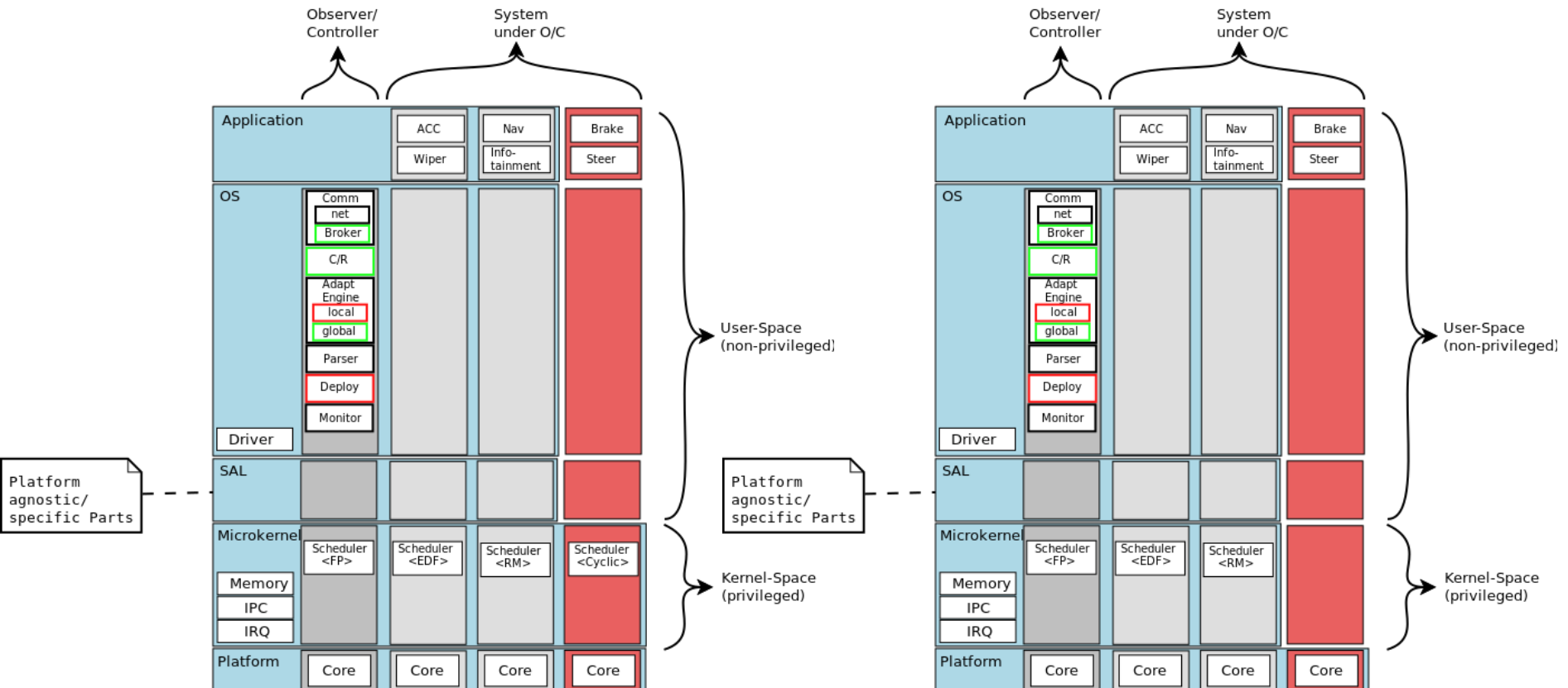

Virtually separated management of best-effort, soft and hard real-time tasks.

Background: Future Trends

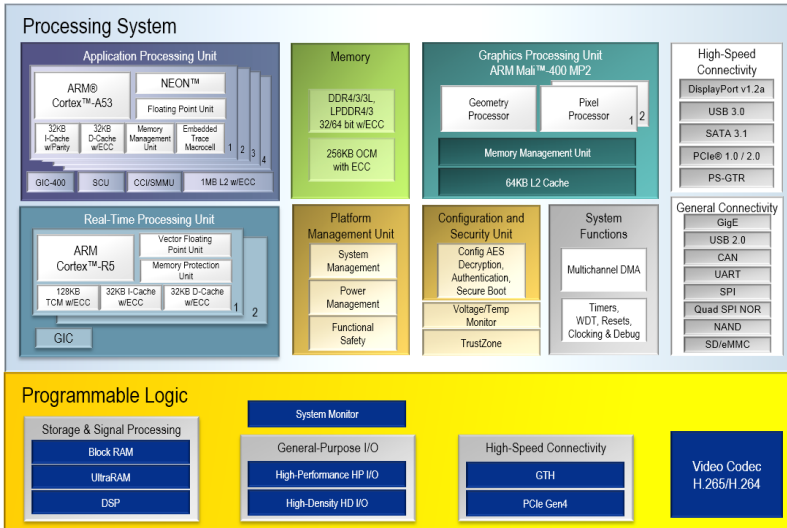

<https://www.xilinx.com/products/silicon-devices/soc/zynq-ultrascale-mpsoc.html>

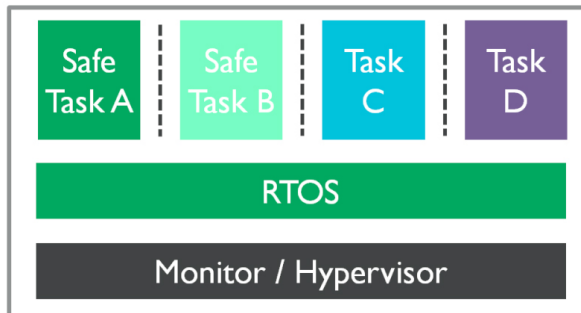

<https://www.arm.com/products/processors/instruction-set-architectures/armv8-r-architecture.php>

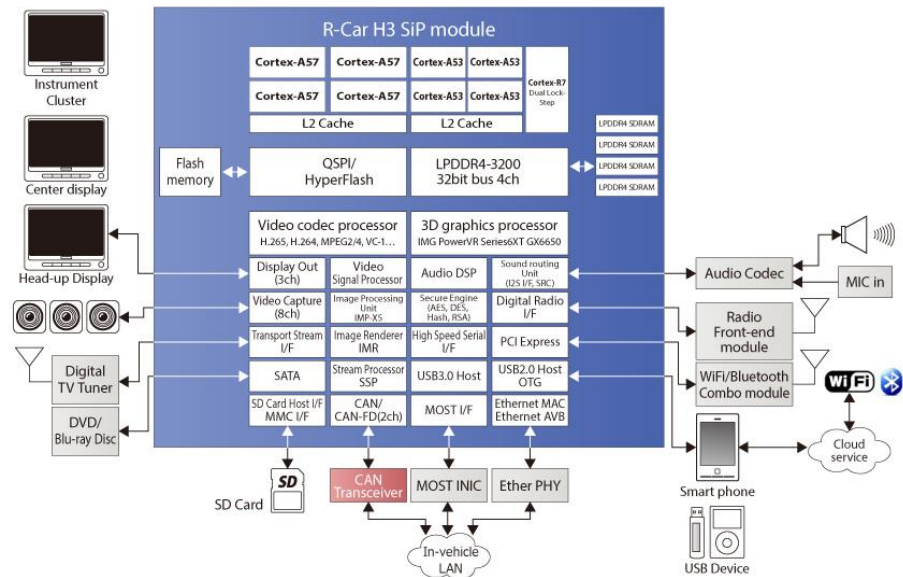

<https://www.renesas.com/en-eu/solutions/automotive/products/rcar-h3.html>

Partitioning – Concept III

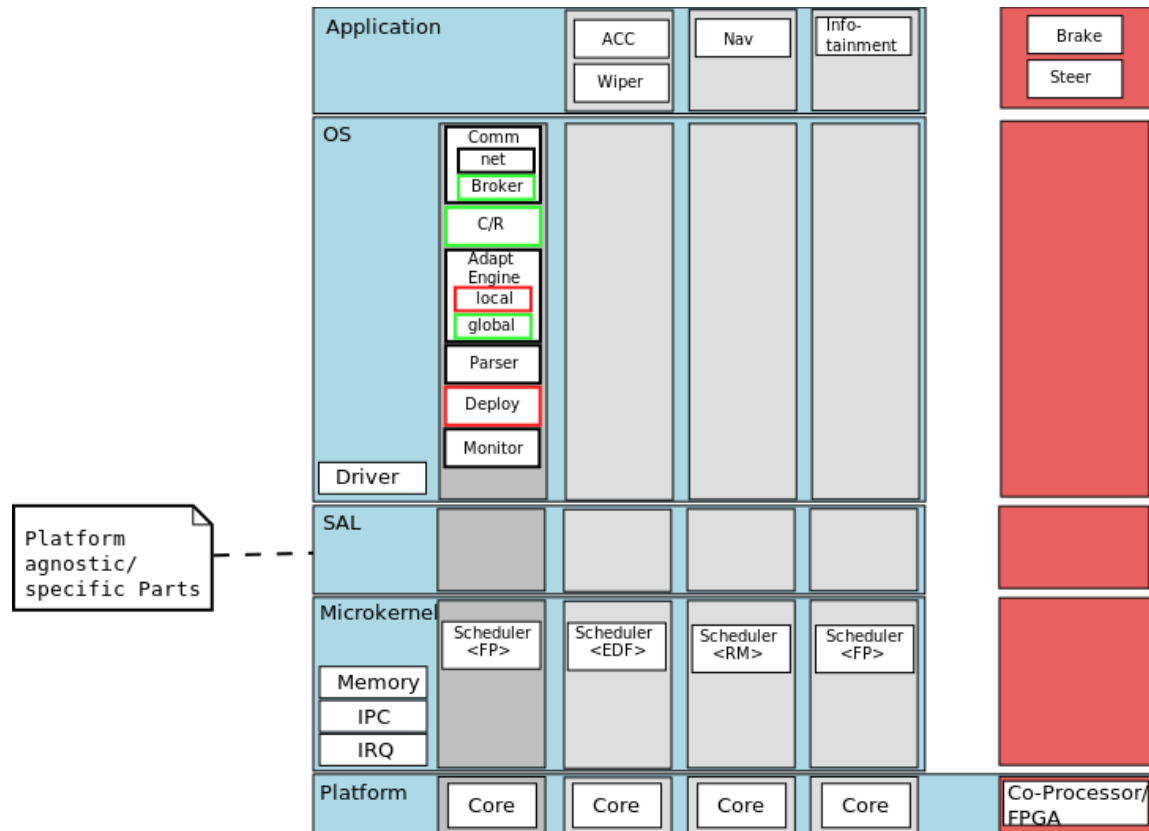

Physically separated management of best-effort, soft and hard real-time tasks.

Partitioning – Prototypical Development

- UDOO Dual/Quad (NXP i.MX6 Cortex-A9 + Arduino Due-compatible ATMEL Cortex-M3)

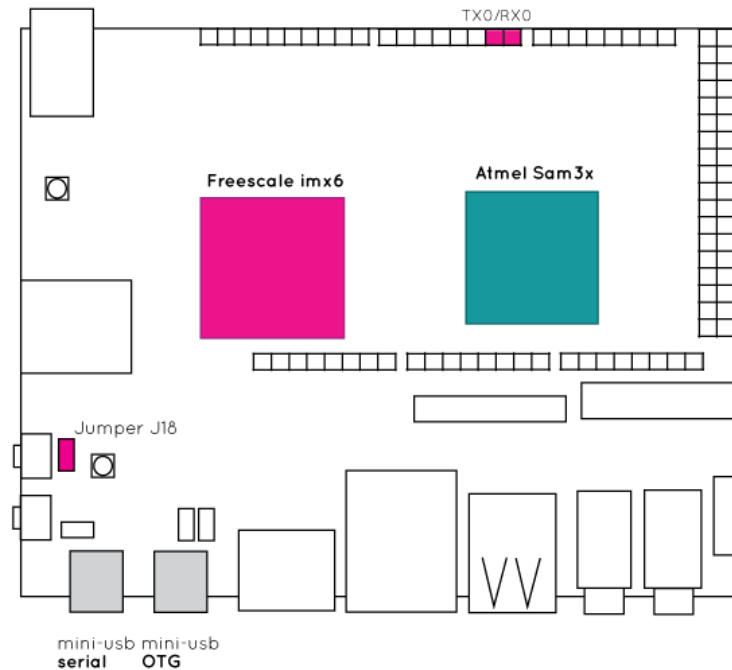

http://www.udoo.org/docs/Hardware_&_Accessories/IMX6_And_Sam3X_Communication.html

Agenda

- About
- Vision
- Project: KIA4SM
- Dynamic Reconfiguration
 - Migration
 - Partitioning
- **Test Setup**
- Next Steps

OS Workflow: Offline & Online systems

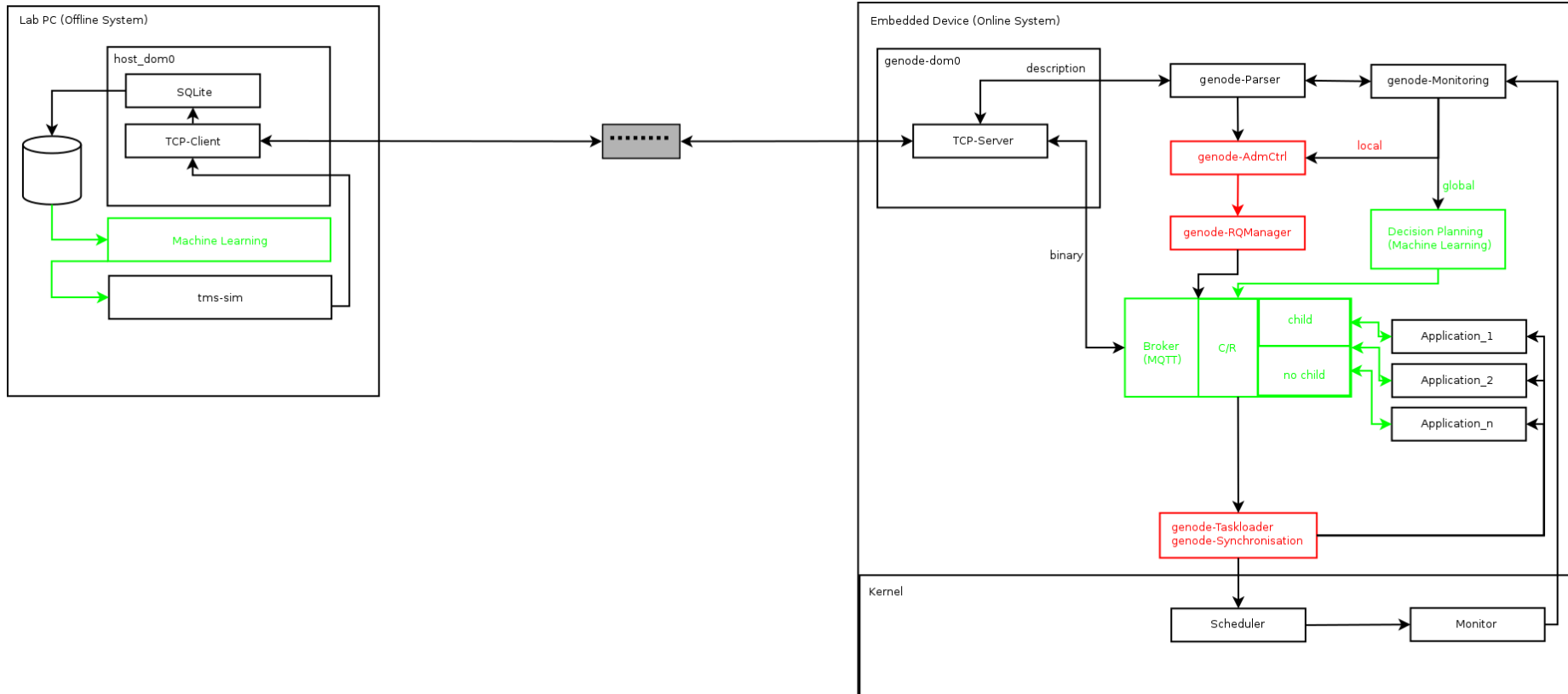

Test Case: Autonomous Driving

- Driving (in convoy)
 - > fail-operational

- Autonomous Parking
 - > fail-safe



https://global.handelsblatt.com/wp-content/uploads/2016/04/Scania_11127-010_sm.jpg

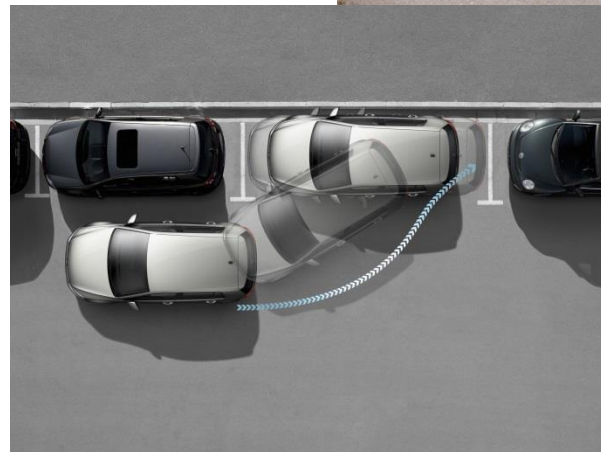

http://www.whichcar.com.au/media/1841/image94342_c.jpg?width=500&height=372.23168654173764

Connection: virtual & physical world

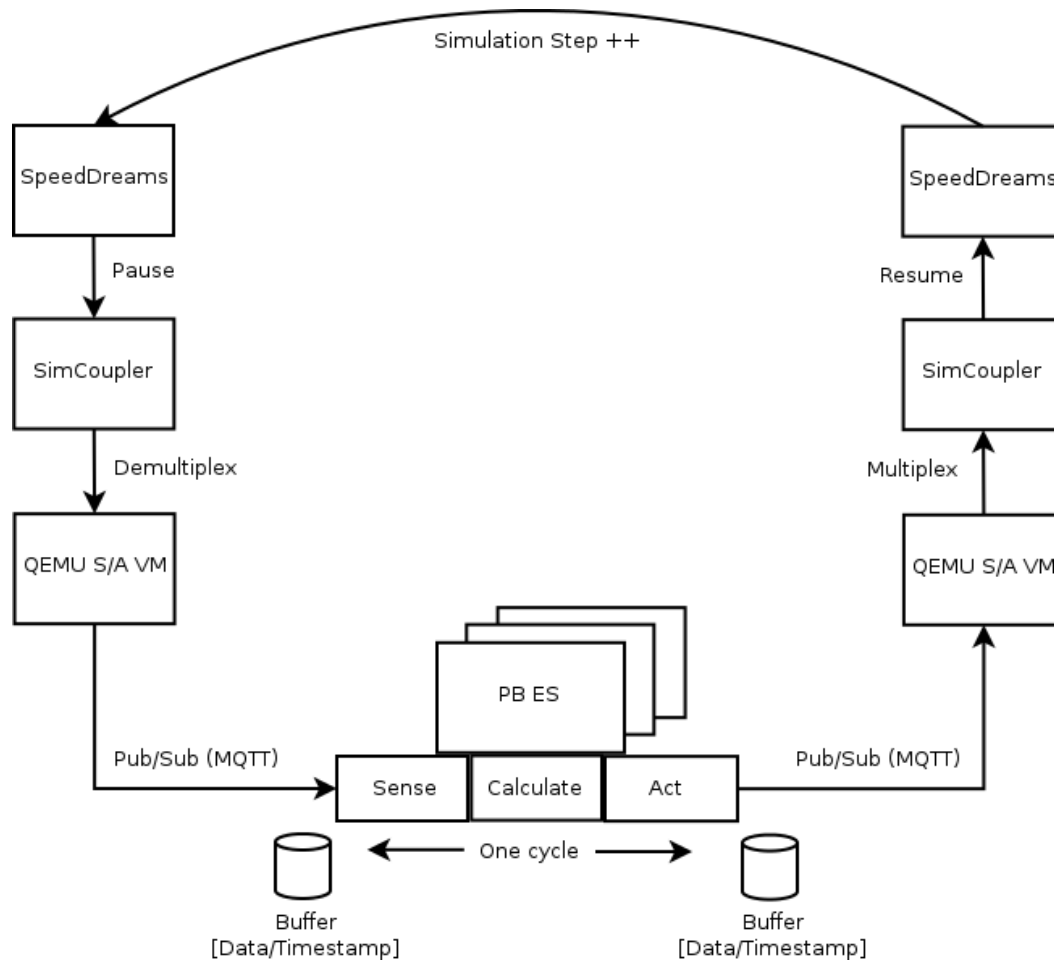

Agenda

- About
- Vision
- Project: KIA4SM
- Dynamic Reconfiguration
 - Migration
 - Partitioning
- Test Setup
- **Next Steps**

Conclusion

- Motivation: Future automotive systems
- Introduction of homogeneous integration architecture to combine virtual and physical world (OC-based microkernel)
- Migration as part of dynamic reconfiguration
- Clearly identified OS research areas
 - Migration planning
 - Checkpoint/Restore
 - Flexible Thread Management
- Test case & Setup
 - Implementation on top of L4 Fiasco.OC and Genode
 - COTS-Hardware in experimental model vehicle

Next Steps

- Evaluation (C/R)
 - Test of migration (+ de/serialization & transfer)
 - Test of migration + decision making
 - Test of migration + decision making + hybrid simulator
- Knowledge-based algorithms
 - Quantification of scheduling decision
 - Algorithms ranging from reactive (classic) to knowledge-based decision making
 - (Autonomous) optimization of decision for better system utilization
- L4/Genode Multi-Core (2+ cores) support
 - Porting of Genode to Quad-/Octa-Core platforms (e.g. Cortex-A9 based Freescale i.MX6 or Samsung Exynos SoCs)
 - Multi-Core placement of C/R, Monitoring and Analysis/Planning

Thank you!

<https://www.os.in.tum.de/>

Daniel Krefft, M.Sc.
TUM – Technische Universität München
Informatik F13 (Operating Systems)
Boltzmannstr. 3
85748 Garching
T: +49 89 289 18791
E: daniel.krefft@tum.de
www.os.in.tum.de

