

Blanking of Stainless Steel

I Pätzold, P Tröber, M Welm* and W Volk

Technical University of Munich, TUM School of Engineering and Design, Chair of Metal Forming and Casting, Walther-Meissner-Strasse 4, 85748 Garching, Germany

E-mail: markus.welm@tum.de

Abstract. Slug pulling, adhesion formation and edge fracture are major challenges in the sheet metal processing industry. They lead to a strong reduction in part quality, process stability as well as profitability. In this study, investigations are carried out on stainless steel X5CrNi18-10 to address the previous mentioned challenges. While slug pulling and edge fracture strongly depend on the geometric characteristics of active elements as well as the selection of process parameters, adhesion formation is mainly determined by temperature and thermoelectric currents. In this publication, the influence of the die channel geometry on the slug pulling effect and the part quality is investigated. Furthermore, the temperature profile over the shear cutting process as well as the resulting thermoelectric currents are determined for the test material. The relationship between edge crack sensitivity, shear cutting parameters and strategies is examined. These investigations thus form the basis for an improved understanding of the shear cutting of stainless steel.

1. Introduction

Blanking is the most widely used method for cutting sheet materials in the serial process due to its profitability. However, depending on the materials to be processed, special aspects must be taken into account. The blanking and forming of stainless steel for example poses great challenges to the sheet metal processing industry, for example slug pulling, adhesive wear and edge-fracture sensitivity.

Starting with the punching of small holes, slugs can be pulled out of the die channel after the separation process, especially when using high cutting rates [1]. In series production, this leads to marks on components [2] and the break-out of active element edges due to the blanking of double sheets [3]. The forces influencing slug pulling can be divided in two categories: Causing and hampering slug pulling. The former include burr clamping, vacuum and adhesive effects [4], the latter gravitation and friction. [5] was able to show, that the adjustment of the geometric properties of the active elements as well as the choice of process parameters can reduce slug pulling effectively.

Since stainless steel strongly tends to form adhesions, galling and adhesive wear are additional major challenges in its processing. A reduction of part quality, process stability as well as an increased risk of tool damage are possible consequences [6]. Therefore, adhesion formation has to be minimized, which is only possible by a profound knowledge of wear causing interactions as well as the associated influencing factors. In addition to the surface roughness of the punch, temperature plays an important role. Both should be as low as possible in order to reduce the amount of adhesions [7]. However, the dissipation of at least 60 % of the plastic work [8] leads to temperatures of up to 230 °C during blanking of stainless steel with a thickness of 2.5 mm [9].



Due to the Seebeck effect, the resulting temperature gradient in the tool causes thermoelectric currents, which also show a significant influence on adhesion formation [10]. Both the current strength and its direction, which are determined by the Seebeck coefficients of tool and sheet material as well as the temperature, show a significant influence on the amount of adhesion on the lateral surface of the punch [11].

The cut surface qualities resulting from the selected process parameters contributes to a large extent to the further processability of stainless steel. Component edges that are severely damaged by shear cutting often fail in further forming process steps due to edge cracks. Especially in blanking tools, which have low stiffness and manufacturing accuracy, displacements of the active elements occur under load, resulting in large deviations of the nominal die clearances and thus of the circumferential cutting surface qualities [12]. An adaptation of the shear cutting process by means of suitable process parameters or the application of two-stage shear cutting enables process-reliable further processing of shear cut edges [13].

The present investigations comprise experimental studies which, on the basis of adapted shear cutting parameters, offer easy-to-apply solutions for the processing of stainless steel under the aspects of slug pulling, adhesive wear and edge fracture.

2. Material

For the investigations, a stainless steel X5CrNi18-10 (1.4301) in different sheet thicknesses was used which, due to its resistance to acids and corrosion, is often used for the processing of components on white goods, but also in the pharmaceutical, food, construction or automotive sectors [14]. The metastable austenitic stainless steel stands out for its good formability, however high plastic deformations lead to a significant increase in strength [15]. The microstructure consists of a homogeneously distributed phase of austenite with linearly embedded delta ferrite and small amounts of deformation martensite. It has a yield strength $R_{p0,2}$ of a minimum of 230 MPa, a tensile strength R_m in a range of 540 to 570 MPa, and a minimum total elongation A_g of 45 % [16].

3. Tools and Methods

3.1. Shear Cutting Tools and Presses

For the experimental investigations several modular shear cutting tools and presses were used. The modular design of the tools allows the variation of a variety of process parameters. [4] gives a detailed description of the tool design with its special features for measuring the vacuum, burr clamping and adhesive force. The investigated die channels used in this experimental study are illustrated in Figure 1.

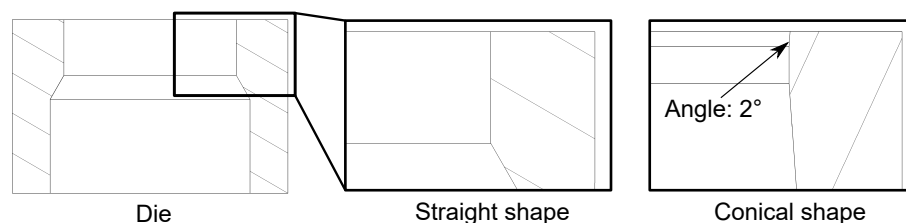

Figure 1. Investigated die channel geometries.

All experiments were conducted on servo-controlled modules of the stamping and forming machine GRM-NC of the company Otto Bihler Maschinenfabrik GmbH & Co. KG, Germany, which features high flexibility in adjustable stroke height and cutting speed.

The experiments on thermoelectric currents were performed on a special blanking tool, where the active elements and the sheet metal are electrically insulated by ceramic applications to prevent interfering signals. Its schematic structure is illustrated in Figure 2. In all experiments,

the active elements consist of the cold working steel X155CrVMo12-1 (1.2379). The circular punch as well as the counter punch exhibited a diameter of 70 mm. The cutting edge radius was $50\ \mu\text{m}$. The HFA 3200 plus from Feintool AG, Switzerland, a hydraulic fine blanking press with a maximum press force of 3200 kN, was used for these experiments.

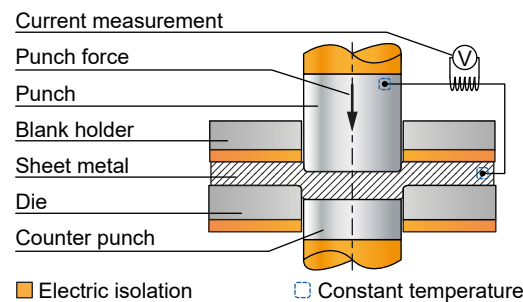

Figure 2. Schematic diagram of the blanking tool for investigating thermoelectric currents.

The edge crack investigations were performed on two different shear cutting tools, which differ mainly in the cutting line geometry. The one for producing the *Edge-Fracture-Tensile-Test* (*EFTT*) specimen according to [17] is shown in Figure 3 a) and described in detail in [19]. Based on the specimen geometry, both an open and closed cutting line can be realized in the tool. The initial geometry and the process steps for manufacturing the specimens are shown in Figure 3 b).

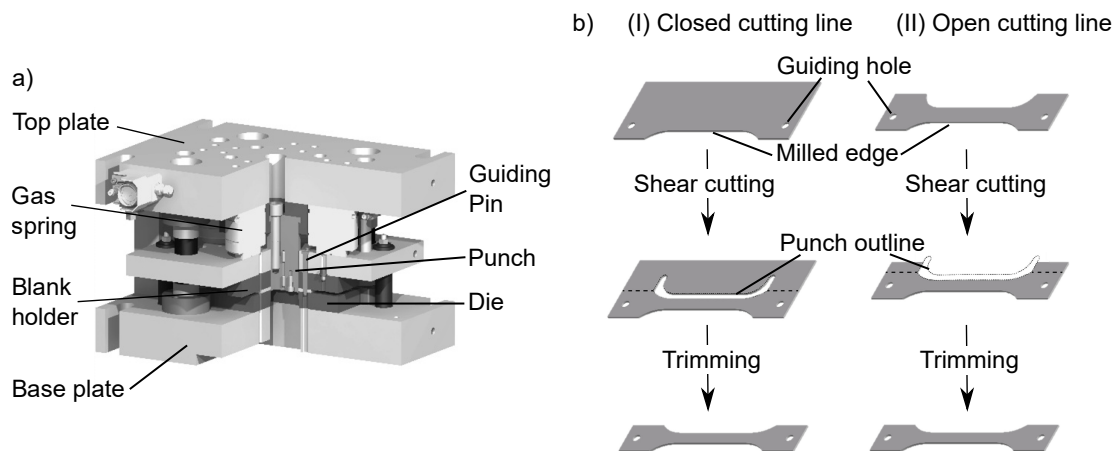

Figure 3. a) *EFTT* Tool design according to [17]. b) Manufacturing of *EFTT* specimen with an open (I) and closed (II) cutting line according to [18].

The second tool, shown in Figure 4 allows the centric placement of a hole in the very middle of the specimen for the hole tensile test as specified in [20]. Both tools were operated on a high-performance automatic stamping press BSTA 1600 from Bruderer AG, Switzerland, with a maximum press force of 1600 kN.

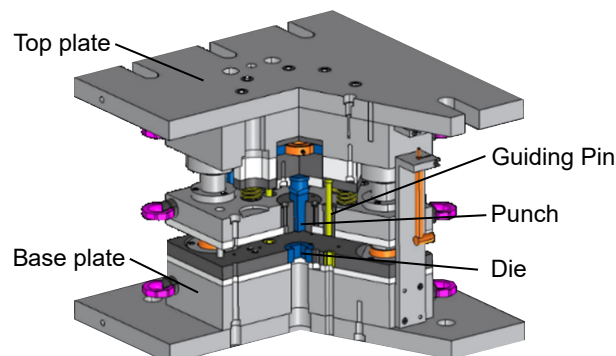

Figure 4. Shear cutting tool for manufacturing Open Hole Tensile Test specimen.

3.2. Measurement Equipment

An assessment of the die channel geometry with regard to its influence on slug pulling requires several data from the tool and the produced parts. The punch force as the most important value for determining frictional forces between slug and die is measured with a piezoelectric sensor in the cutting unit. A parallel tactile travel sensor gauges the punch travel. Both signals are recorded with a sample rate of 100 kHz. For classifying the part quality, the geometric characteristics of the shear cut surfaces are recorded by the digital microscope VKX-100, from Keyence, Japan. This microscope was also used for the initial inspection of the active elements.

Both the direction and the strength of the thermoelectric currents were measured using the K2 current clamp from Chauvin Arnoux, France, in a closed electrical circuit, consisting of punch, sheet metal and a connecting wire. In order to relate this data to the entire blanking process, occurring forces and the punch travel were also recorded.

To evaluate the edge crack sensitivity, the Aramis SRX contactless optical deformation analysis system from GOM mbh, Germany was used to capture the strain distribution which appears on the specimen surface during testing. This enables to differentiate between the failure types deformation fracture and edge crack [21]. Furthermore, it was used to determine the maximum major strain before failure of the specimen. The evaluation of the geometric characteristics of the shear cut surfaces was performed using the digital microscope VHX 2000, from Keyence, Japan.

3.3. Experimental Design

Figure 5 illustrates the experimental procedure, including all blanking parameters for determining the guidelines for processing stainless steel with regard to blanking. During the slug pulling experiments, the influence of two different die channel geometries on the cutting forces and the friction between slug and die, as well as the part quality, was investigated on 0.7 mm thick sheet material. While slug pulling is a common problem when blanking small geometries, the shear cut surface characteristics of the stamping grid serves as quality criterion. The two examined die geometries are a common one with a straight channel and a conical one with a channel angle of 2° , corresponding to a compression of the slug of 0.14 mm at the maximal immersion depth of 1.85 mm. Every experiment is divided in three strokes: The first is the typical stroke up to an immersion depth of 1.4 mm, in which the material is separated. For the second stroke the stamping grid is removed and inserted distance sheets push the slug to a depth of 2 mm. For determining the frictional force between punch and guide bush, the third stroke is performed without stamping grid and slug, but with distance sheets. The force of the third stroke is then subtracted from the one of the second stroke. This enables an investigation of the frictional forces between slug and die without the influence of other friction during the blanking process.

| Investigated Material X5CrNi18-10 (1.4301), thickness 0.7 mm, 1.5 mm, 4 mm | | |
|--|---|---|
| Slug Pulling | Adhesion Formation | Edge Cracking |
| Blanking Parameters <i>Variated Parameters</i> Die Channel Geometry Straight / Conical (2°) <i>Unchanged Parameters</i> Die Clearance u_r 14 % Punch Diameter 5 mm Die Channel Length 2 mm Cutting Edge Radius 30 μm | Blanking Parameters <i>Punch velocity</i> 5 / 40 / 70 mm/s <i>Die Clearance u_r</i> 1 / 5 / 10 % <i>Unchanged Parameters</i> Seebeck Coefficient of Punch / Sheet Metal Punch Diameter 70 mm Cutting Edge Radius 50 μm | Blanking Parameters <i>Variation Cutting Line Type</i> Open / Closed Cutting Line Die Clearance u_r 5 / 10 / 15 / 20 / 25 % <i>Variation Shear Cutting Strategy</i> One-stage / Two-stage Die Clearance u_r 10 % Cutting Offset z 0.2 / 0.3 / 0.4 / 0.5 / 1.0 mm |
| Characterization <i>Optical Shear Cut Surface Characterization</i> <i>Frictional Force Determination</i> | Characterization <i>Seebeck Coefficient</i> <i>Optical Punch / Shear Cut Surface Characteriation</i> | Characterization <i>Optical Shear Cut Surface Characterization</i> <i>Edge-Fracture-Tensile-Test</i> |
| Development of Guidelines for the Processing of Stainless Steel in Blanking | | |

Figure 5. Experimental procedure.

Since the amount of adhesion formation increases with the naturally arising thermocurrent in case of the same current direction [11], this investigation focuses mainly on the influence of process parameters on these currents. Therefore, both die clearance and punch velocity was varied and the occurring thermoelectric current was measured. In order to relate the curve of the latter to the entire blanking process, the punch-, counterpunch- and blank holder forces as well as the punch travel were measured simultaneously. After nine consecutive strokes, three each per punch velocity, the amount of adhesions on the lateral surface of the punch was documented optically. All tests were repeated several times so that all values given were averaged over at least five strokes. In all the presented experiments, no lubricants were applied.

For the edge crack investigations the influence of cutting line type in combination with different die clearances as well as the shear cutting strategy, examining the influence of the width of cutting offset was varied on 1.5 mm thick stainless steel. To determine the influence of the cutting line type the *EFTT* was used. In order to investigate the influence of two-stage shear cutting on the residual forming capacity, hole tensile tests were performed with a hole diameter of 10 mm and a specimen width of 30 mm. All experiments were carried out with sharp-edged ($r < 10 \mu\text{m}$) active elements. The large range of die clearances was chosen due to possible displacements in the series process. In a worst-case scenario, when the nominal die clearance is 10 %, this means that 0 % die clearance can occur on one side of the contour and 20 % on the other side. For the two-stage shear cut specimens, the die clearance for the first and second step was selected to be $u_{1st} = u_{2nd} = 10 \%$. All specimens were tested transverse to the rolling direction. For both methods the tests were performed using optical measurement with a measuring frequency of 10 Hz. The frequency was doubled shortly before fracture (20 Hz), which enables to determine the crack initiation even more precisely.

4. Results and Discussion

4.1. Slug Pulling

4.1.1. Frictional forces

Varying the die channel geometry has a significant influence on the frictional forces between slug and die, shown in Figure 6 a). The straight die geometry triggers a maximum force of 495 N, right after the punch gets in contact with the slug. Subsequently, from 1.47 mm the force slightly declines due to leveling of roughness asperities and the slug starting to leave the die channel, which causes the area of contact between clean shear and die getting smaller. From 1.75 mm to 1.85 mm the slug is completely pushed out of the die channel and thus the force decreases rapidly.

With a conical channel geometry the force reaches 1127 N when the punch starts pushing the slug. In contrast to the straight geometry the force raises up to 1252 N at 1.69 mm. After that, the decreasing area of contact exceeds the effect of slug compression and thus the force drops. The overall higher friction forces with the conical die are caused by higher radial forces due to two mechanisms: First, a compressive stress is induced in the slug during the cutting process which causes a higher elastic spring back after material separation. Second, the compression of the slug increases with higher immersion depth, which enhances the slug oversize. With higher frictional forces between slug and die, the conical die provides a higher probability of preventing slug pulling.

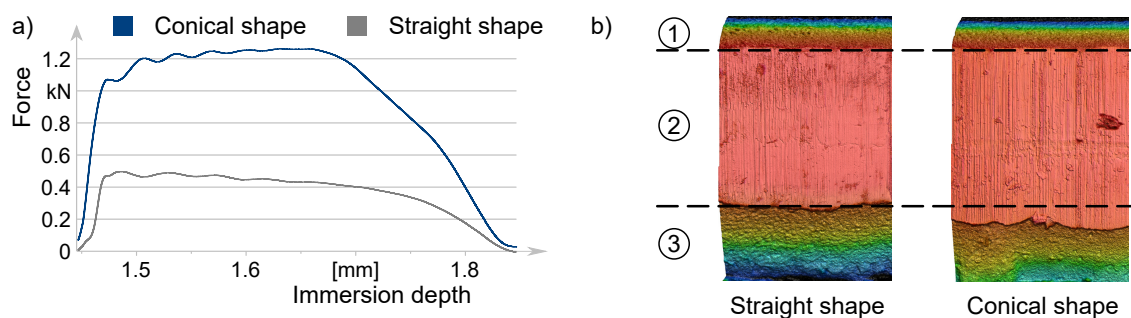

Figure 6. a) Frictional forces between slug and die from an immersion depth of 1.45 mm to 1.85 mm where the clean shear leaves the die channel. b) Shear cut surface characteristics for both die variants with roll-over (1), clean shear (2) and fractured surface (3).

4.1.2. Part Quality

A higher compression stress for the conical shape of the die channel also affects the shear cut surface characteristics, as illustrated in Figure 6 b). While the rollover is nearly constant with 14.7% for the straight shape and 14.9% for the conical shape, respectively, the clean shear proportion differs. It is 54.0% for the straight channel compared to 60.8%. Also the percentage of the fractured surface changes from 31.3% to 24.4%. This can be explained by the higher compression stress retarding the crack initiation. Furthermore, this stress condition changes the fracture angle from 23.5° for the straight geometry to 20.2° . This shows that changing the geometry of the die to avoid slug pulling can significantly influence the component properties.

4.2. Adhesion Formation

Figure 7 illustrates the maximum thermoelectric currents, arising during blanking 4 mm stainless steel with the above-mentioned setup. Furthermore, it shows the lateral surface of the punch next to the cutting edge for the respective die clearance.

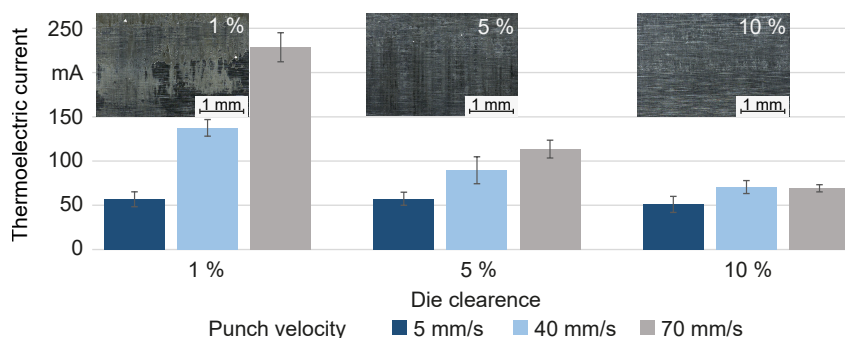

Figure 7. Thermoelectric current depending on the die clearance and punch velocity as well as the lateral surface of the punch

While the maximum currents were averaged over at least three strokes, the punch surface was photographically documented after nine consecutive strokes. The positive current values indicate

a technical current direction from punch to sheet metal. This can be traced back to the Seebeck coefficients of punch and sheet metal since these alone determine the thermoelectric current direction. With regard to adhesion formation, this direction has a reinforcing effect [11]. The maximum thermoelectric current rises significantly with increasing punch velocity and decreasing die clearance. For a die clearance of 1%, the maximum thermocurrent in case of the lowest punch velocity amounts to 56.8 mA. The maximum current rises to 137.5 mA for 40 mm/s and to 228.6 mA for 70 mm/s, which can be attributed to the increasing temperature due to a reduced time for heat equalization [10]. In sum, the lowest velocity reduces the thermoelectric current by 75.2% compared to the highest one. However, the influence of punch velocity decreases with an increasing die clearance. While the reduction amounts to 49.5% for a die clearance of 5%, it is only 26.4% for 10%. Furthermore, almost no difference in the thermocurrent occurs between a velocity of 40 mm/s and 70 mm/s in the latter case. The decreasing impact of velocity can be attributed to the lower clean cut portion, which results in a decreasing amount of conducted forming work and thus a lower process temperature. This effect is enhanced by the growing shear zone in which the dissipated energy is distributed. When comparing the lateral surfaces of the punch between all die clearances, it can be seen that a die clearance of 1% leads to the highest amount of galling. Almost the entire area at the cutting edge is covered with adhesion. In case of 5% die clearance, a considerably less amount of adhesion occurs. However, adhesions, which are formed primarily on the grinding marks, can still be recognized. A die clearance of 10% exhibits the lowest amount of galling, with only a few local adhesions. The results show that the thermoelectric current strength qualitatively correlates with the amount of adhesion, which increases significantly with smaller die clearances due to higher surface pressures and temperatures.

4.3. Edge Fracture

4.3.1. Variation of Cutting Line Type

Figure 8 shows the influence of an open and closed cutting line as well as different die clearances on the major strain distribution of the specimen surface before failure and the shape of the cut surfaces by means of single-stage *EFTT*. It can be seen that the way of strain distribution strongly depends on the shear cutting parameters used. All specimens produced with a closed cutting line fail from the edge in the range of die clearances from 5 to 25%. Specimens with die clearances $u_r < 15\%$ are particularly sensitive and show typical edge cracks. Here, a strain hot spot forms at the shear cut edge and the specimen fails at very low strains without global necking. For the open cutting line, only specimens produced with die clearances $u_r > 15\%$ fail from the edge, specimen with $u_r = 25\%$ due to edge crack.

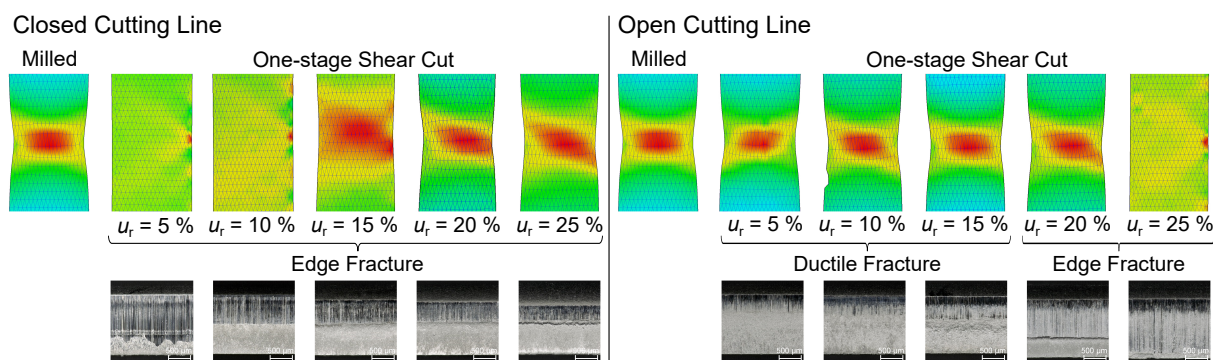

Figure 8. Strain distribution before fracture and photographic documentation on *EFTT* specimens for open and closed cutting line with variable die clearance.

The reason for this is the high proportion of clean shear as well as the strong burr formation, which causes high notch stresses. The advantage of the open cut over a closed cutting line is in

particular the lower stiffness of the slug. The slug can bend downwards the punch face and thus provokes a tensile stress at the punch edge. This results in an earlier fracture, a reduced roll-over and clean shear zone and, consequently, a significant reduction in strain hardening and damage within the shear affected zone. As Figure 9 shows, selecting an open cutting line with adapted shear cutting parameters ($u_r = 5$ to 15 %) leads to almost no reduction in the forming capacity of the component edge.

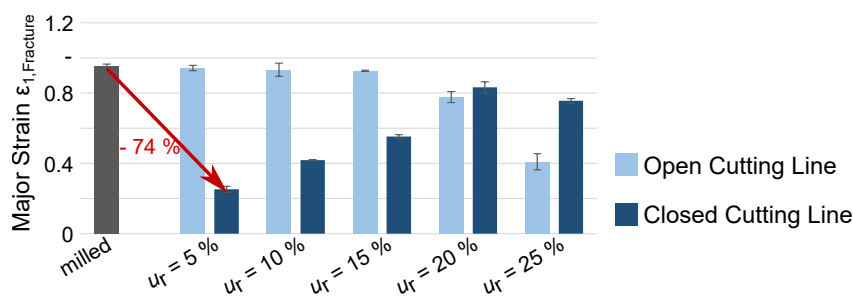

Figure 9. Major strain before failure determined in *EFTT* for different cutting line types and die clearances.

In the case where closed cutting lines are required for production purposes, further processing of the shear-cut specimen edges is considered critical in the case of one-stage shear cutting. Deviations from the die clearance in the tool under load can reduce the edge forming potential by up to 74 %.

4.3.2. Variation of Shear Cutting Strategy

To avoid the risk of edge cracks, especially in the closed cut, two-stage shear cutting has already been successfully applied for high strength steels in [13]. When using two-stage shear cutting, in the first shear cutting process, a hole smaller by the width of the cutting offset z is precut at critical points of a punching process. The scrap in the first step is fixed circumferentially and is therefore displaced mainly in vertical direction. This leads to a strong work hardening in the area of the later shear cut edge. In the second shear cutting process, only a ring with the width of the cutting offset z is removed. The scrap is free to move in vertical and radial direction. The hardening resulting from the first step is thus removed, and the deformation occurring in the shear affected zone of the second step is almost completely transferred to the scrap if the process parameters are selected appropriately.

For the stainless steel X5CrNi18-10, the residual forming capacity could also be increased in the investigations by applying a two-stage shear cutting process. For single-stage punching, the residual forming capacity for the investigated range increases with larger die clearances. Figure 10 shows that with sharp active element edges, die clearances in the first and second step of $u_{1st} = u_{2nd} = 10\%$ and cutting offsets in the range between 0.3 mm and 1.0 mm, the forming capacity of two-stage shear cut edges almost reaches that of the milled specimens. The photographic documentation shows that for single-stage shear-cut specimens with hole diameters of $D = 10$ mm, the clean shear portion decreases with increasing die clearance.

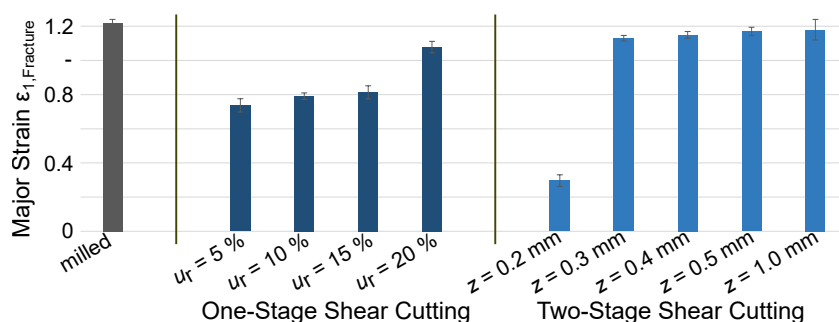

Figure 10. Major strain before failure determined in hole tensile tests for different shear cutting strategies and cutting offsets.

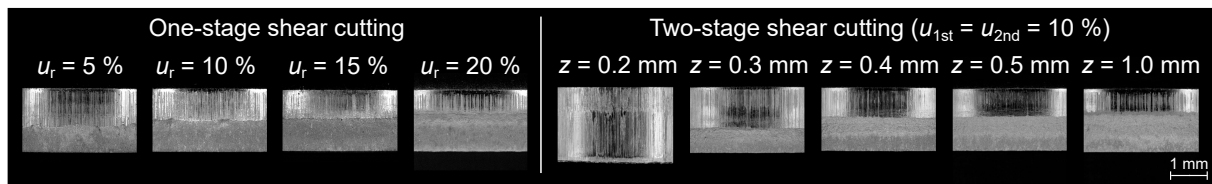

Figure 11. Photographic Documentation of punched specimen with a diameter of $D = 10$ mm under one-stage and two-stage shear cutting.

This leads to a lower work hardening in the shear affected zone and thus to a higher residual forming capacity. The shear cut surface of the two-stage shear cut specimen with a cutting offset of $z = 0.2$ mm has a very high proportion of clean shear as well as a large burr, which leads to a strong reduction in the achievable forming capacity. Although the proportion of clean shear is higher than in the single-stage punching, a cutting offset of $z = 0.3$ mm allows an increase in the residual forming capacity, which is due to the fact that most of the deformation from the first step of punching ends up in the slug of the second process step, as described in [13]. For increasing widths of the cutting offsets, a lower clean shear percentage is achieved than in the single-stage trim. This also correlates with the achievable major strains in the hole tensile test.

5. Conclusions

The following conclusions can be drawn for the investigations carried out on slug pulling, adhesion formation and edge fracture using the stainless steel X5CrNi18-10 (1.4301):

The die channel geometry has significant influence on the frictional forces between slug and die. Consequently, the right choice of the geometry helps to reliably prevent slug pulling. A conical shaped die channel with an angle of 2° enhances the frictional force by a factor of 2.5. Changing the stress conditions during the cutting process due to other die channel shapes affects the shear cut surface characteristics and thus part quality. Especially the crack initiation is affected and thus the amounts of clean shear and fractured surface.

With regard to the thermoelectric current, a strong influence of the punch velocity could be revealed in case of a small die clearance. For a relative die clearance of 1%, the current strength is about four times higher in case of the highest punch velocity, compared to the lowest one. With an increasing die clearance, this influence decreases and becomes negligible in case of 10%. With regard to adhesion formation, the current strength qualitatively correlates with the amount of adhesion on the lateral surface of the punch. Therefore, the process parameters should be chosen appropriately in order to keep thermoelectric currents as low as possible. In the presented setup, the results suggest a die clearance of at least 5%. Compared to 1%, similar shear cut surface qualities could be reached, while adhesion formation and thus galling on the lateral surface of the punch could be reduced significantly.

Single-stage shear cutting of stainless steel with open cutting line should be performed with die clearances of 5 to 15% to reduce the risk of edge cracks occurring. The reason for this is a bending of the waste and thus tensile stresses at the punch edge which cause an earlier crack initiation and consequently lower work hardening in the shear affected zone. In single-stage shear cutting, the lowest possible smooth cut percentage should be achieved. In the event that a closed cut is required for production reasons, it is advisable to use a two-stage shear cutting process to increase the edge formability. The two-stage shear cutting allows the material to flow radially and vertically, removing the hardening from the first step and shifting nearly all of the work hardening from the second shear cutting process to the scrap. For a hole diameter of $D = 10$ mm cutting offsets between 0.3 and 1.0 mm allow a significant increase in residual formability.

References

- [1] Tittel V and Bernadic L (2012) *A review of methods and precautions against slug pulling*; International Journal of Pure and Applied Sciences and Technology **12(1)**

- [2] Dannemann E, Sugundo S, Lange K (1981) *On the Adhesion of Blanks to the Punch in Blanking and Piercing* Annals of the CIRP **30/1/1981** doi:10.1016/S0007-8506(07)60917-2
- [3] Strasser F (1963) *Wie vermeidet man das Hoch-kommen von Butzen und Ausschnitten?* Werkstatt und Betrieb **96** pp. 319-320
- [4] Kindsmüller A, Schrepfer A, Stahl J, Pätzold I, Nürnberger A, Golle R, Volk W (2021) *Influence of cutting parameters on mechanisms causing slug pulling* Production Engineering **15** doi:10.1007/s11740-021-01061-3
- [5] Stahl J, Pätzold I, van den Bosch L, Kindsmüller A, Golle R, Volk W (2021) *The Frictional Force between Slug and Die in Shear Cutting after Material Separation* Key Engineering Materials **833** doi:10.4028/www.scientific.net/KEM.883.285
- [6] Golovashchenko S (2006) *A study on trimming of aluminum autobody sheet and development of a new robust process eliminating burrs and slivers* International Journal of Mechanical Sciences **12** pp. 1384–1400 doi:10.1016/j.ijmecsci.2006.07.007
- [7] Tröber P, Welm M, Weiss H A, Demmel P, Golle R, Volk W (2021) Temperature, thermoelectric current and adhesion formation during deep drawing WEAR **477** doi: 10.1016/j.wear.2021.203839
- [8] Talonen J, Hanninen H (2007) *Energetics of plastic deformation of metastable Austenitic stainless steel* Steel Res. Int. **78** pp. 260–265 doi:10.1002/srin.20070588
- [9] Tröber P, Welm M, Weiss H A, Demmel P, Golle R, Volk W (2019) The influence of process parameters and sheet material on the temperature development in the forming zone Manufacturing Review **6** 9 doi:10.1051/mfreview/2019005
- [10] Tröber P, Demmel P, Golle R, Volk W (2017) On the influence of Seebeck coefficients on adhesive tool wear during sheet metal processing CIRP Ann. -Manuf. Technol. **66** pp. 293–296 doi:10.1016/j.cirp.2017.04.116
- [11] Welm M, Tröber P, Weiss H A, Demmel P, Golle R, Volk W (2020) Thermoelectrically Based Approaches to Reduce Adhesive Wear During Blanking JOM - The Journal of The Minerals, Metals Materials Society (TMS) **72**
- [12] Larour P, Freundenthaler J, Essbichl R, Kerschbaum M (2017) *Influence of shear cut edge condition on conical hole expansion ratio* SCT2017 5th International Conference on Steels in Cars and Trucks 2017, Amsterdam-Schiphol, Netherlands
- [13] Gläsner T, Sunderkötter C, Hoffmann H, Volk W, and Golle R (2017) *Development of a 2-stage shear cutting-process to reduce cut-edge-sensitivity of steels* Journal of Physics Conference Series **896** doi:10.1088/1742-6596/896/1/012104
- [14] Rana R (2018) *High Performance Ferrous Alloys* Springer doi:10.1007/978-3-030-53825-5
- [15] N N (2013) *Handbook of Stainless Steel* Outokumpu Oyj, Finland
- [16] DIN EN 10088-2 (2022) *Stainless steels - Part 2: Technical delivery conditions for sheet/plate and strip of corrosion resisting steels for general purposes*; Beuth Verlag GmbH: Berlin, Germany
- [17] Feistle M, Krinninger M, Pätzold I, Volk W (2015) *Edge-Fracture-Tensile-Test, 60 Excellent Inventions in Metal Forming* Springer Chapter 30, pp. 193-198 doi:10.1007/978-3-662-46312-330
- [18] Feistle M, Golle R, Volk W (2015) *Determining the influence of shear cutting parameters on the edge cracking susceptibility of high-strength-steels using the edge-fracture-tensile-test* 48th CIRP Conference on Manufacturing Systems - CIRP CMS 2015
- [19] Feistle M, Krinninger M, Pätzold I, Stahl J, Golle R, Volk W (2017) *Design and conceptualization of a cutting tool to investigate the influence of the shear cutting process on edge crack sensitivity* Journal of Physics **896** doi:10.1088/1742-6596/896/1/012106
- [20] Feistle M, Pätzold I, Golle R, Volk W (2019) *Open hole tensile tests for the determination of the edge-crack sensitivity of sheared holes dependent on specimen geometry, cutting parameters, and the notch factor* 18th International Conference on Sheet Metal **29** pp. 412-419 doi:10.1016/j.promfg.2019.02.156
- [21] Pätzold I, Feistle M, Golle R, Hoffmann, Volk W, Frehn A, Ilksens R (2017) *Identification of Edge Crack Sensitivity on Shear Cut Component Edges made of High-Strength Materials using suitable Testing Methods* 5th International Conference on Steel in Cars and Trucks