

# Data Acquisition and Visualisation for IEQ Assessment: A case study of daylight field measurement

JIHYUN PARK<sup>1</sup>, TSUNG-HSIEN WANG<sup>2</sup>, ANDREW WITT<sup>3</sup>, VIVIAN LOFTNESS<sup>1</sup>

<sup>1</sup>School of Architecture, Carnegie Mellon University, Pittsburgh, PA, USA

<sup>2</sup>University of Sheffield, Sheffield, UK

<sup>3</sup>Gehry Technologies, Los Angeles, CA, USA

*ABSTRACT: Indoor environmental quality (IEQ) of buildings can have strong effects on occupants' productivity and health. Post occupancy evaluation (POE) and associated processes have been emphasized as a crucial stage for energy conservation and occupants' comfort and satisfaction of the building. Preliminary research has shown that POE supports opportunities for energy savings while meeting or exceeding IEQ standards. Current practice of mapping measured data with existing building components is manual and lack of flexibility of accommodating time-series building performance measurements. In order to support POE, we propose an integrated process to automate the measured field data mapping to assist building performance visualisation. For the demonstration, we take the full-grid lighting quality measurements in an unoccupied LEED gold certified building in Los Angeles, California, USA. The outcomes are presented to show how measured performance data can be updated with the associated building elements automatically. We further compare the measured and simulation data statistically and visually. Gaps between measured and simulated performance are also discussed.*

*Keywords: Indoor environmental quality; post occupancy evaluation; data acquisition; data visualization*

## INTRODUCTION

Building performance measurements are essential for evaluating how a building performs in terms of quantifiable qualitative attributes, which include visual quality, air quality, acoustics, and thermal comfort. These attributes are key indices of indoor environmental quality (IEQ) and represent the core of post occupancy evaluation (POE). Post occupancy evaluation is one of the most important approaches to reducing energy consumption and enhancing indoor environmental quality. One notable advantage is that POE helps identify building performance gaps and potential improvements based on the existing built environment context [2, 6].

POE processes include (1) collecting IEQ indices of thermal, air, visual, and acoustic conditions, (2) comparing measured IEQ data with recommendation levels such as ASHRAE standards [1] and the IESNA handbook [2], and (3) providing environmental quality report (EQR) with comprehensive analyses for IEQ, occupant comfort, and on-going energy savings [4]. These processes also generate critical indicators to improve energy consumption and user satisfaction by fine-tuning existing building systems. However, the processes of conducting POE from building performance data acquisition to post-evaluation data visualization are usually very labour intensive [5].

The tools used in POE include plan analysis, monitoring of IEQ conditions, observations and user-

satisfaction surveys. The main purpose of these tools is to help understand interrelations among building IEQ conditions, occupants and the operational building systems [5]. During the evaluation processes, IEQ data collected from numerous devices are, in most cases, presented in distinctive format. The non-unified data representation imposes a lot of efforts for the post-evaluation analyses.

To improve the workflow from POE data acquisition to post-evaluation analyses, we propose an integrated IEQ assessment approach, in which time-series data is updated automatically via a cloud-based platform. This approach affords seamless data aggregation and automates the data integration with associated building geometry.

Given an integrated workflow, POE data can be managed and synchronized in real time. This proposed workflow aims to improve the current POE processes, and in turn provides immediate post-evaluation visual feedback. Figure 1 illustrates the integrated workflow consisting of (1) data acquisition, (2) data processing and mapping, and (3) data visualization. Data acquisition includes acquiring technical attributes of building systems, climate information, and measured IEQ data. Data processing and mapping automate the integration of measured field data with corresponding building geometry retrieved at the first stage. Visualization generates graphical output in various forms.

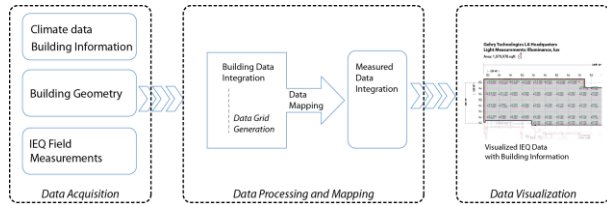

Figure 1 Structure of data acquisition and visualization for IEQ assessment

### FULL-GRID FIELD MEASUREMENT

We use visual quality analyses as the pilot study to demonstrate the integrated IEQ assessment workflow. A lighting quality study was conducted in an unoccupied office (core and shell), in Los Angeles, California, USA (Figure 2). The purpose of using an un-occupied space is to ensure better indoor environmental quality. One potential application could be for improving performance simulation with real environmental data. Also, the pre-occupied indoor environmental setting allows us to examine the actual lighting quality without the interference from the interior furniture and artificial lighting fixtures.

As a basic level, spot measurements are taken via a regular grid system to cover entire surface. We followed ASHRAE Performance Measurement Protocols for Commercial Buildings guide line [1]. Typically the spacing between measurement points is set to one-fourth the spacing between luminaires. The height of these points depends on where the primary task is performed. For instance in most office spaces, the task is found at the desk level and thus points are measured at 0.76 meters (2.5') above the floor. For some spaces where the primary task is walking, the measurements are taken at floor level [1].

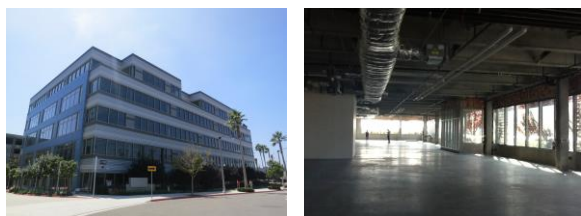

Figure 2 Unoccupied office building for measurement. (Left) exterior; (Right) interior, in Los Angeles, CA, USA

For our visual quality field measurement, OMEGA HHLM-2 digital light meter was utilized for illuminance level. To investigate possible glare issues of the space, HDR (High Dynamic Range) photography was utilized to evaluate the luminance level. Figure 3 shows the luminance fisheye images captured at the same location in the space.

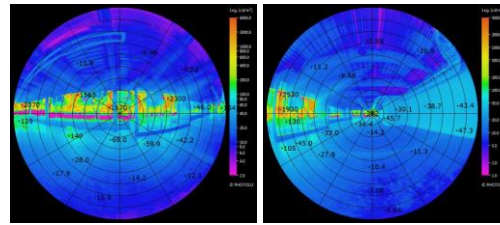

Figure 3 Luminance level: fish eye images

For the full-grid measurement, iPad tablet is used for data recording and synchronization. All the collected data are streamlined to the cloud-based platform using prescribed data protocols in relation to its physical location context. In total, 372 points were measured at both desk and floor levels in the morning (10:30 am-12:00 pm) and afternoon (3:30 pm -5:00 pm).

### DATA RETRIEVAL AND MAPPING

In this section, we describe how data are streamlined via a cloud-based environment, followed by the computational processes that enable post-evaluation data visualisation. For the demonstration purpose, we utilize multiple software packages and services for data synchronization, mapping and analyses. The objective is to demonstrate the feasibility of cross-platform interoperability using cloud. For the data operation, we use DropBox [8], which provides cloud-based hosting services for easy file storage and management. In this workflow, data stored in the cloud can be accessed via a uniform resource locator (URL), which serves as a distinct web address for information retrieval. With these URLs, a computational procedure was implemented with customized components using Grasshopper in Rhinoceros3D [9, 10]. Figure 4 illustrates the snippet of the proposed generative process, in which we reconstruct the parametric relationships between measured field data and associated building geometric elements. The structured parametric relationships allow us to explore various types of analyses and generate graphical outputs in real time. The generative workflow in Grasshopper follows a left-to-right fashion.

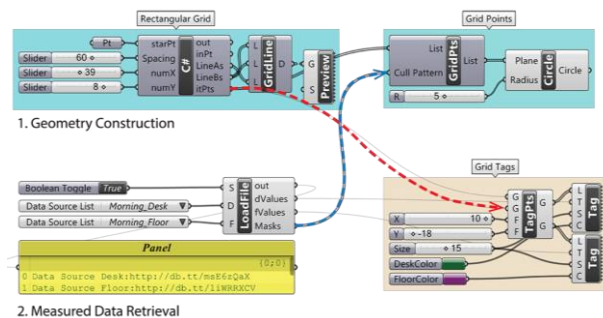

Figure 4 The computational workflow of mapping measured data with associated geometric components in Grasshopper, Rhinoceros 3D

## DATA VISUALIZATION

With the implemented procedure, Figure 5 illustrates measured illuminance data superimposed on the building floor plan. The actual illuminance levels are drawn at the corresponding measure spots and shaded in two distinct colours, green for desk-level and purple for floor-level measurements. With the access to the files stored in cloud, a series of integrated floor plans with associated illuminance levels can be generated/updated automatically.

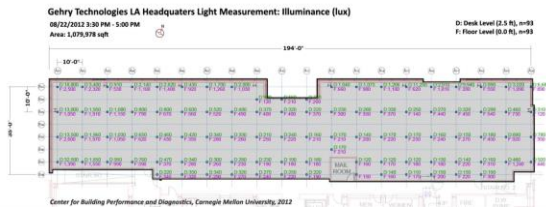

Figure 5 Daylight measurement data application

To better represent these numeric data in a more comprehensible manner, we also employ a carpet plot style to colour floor areas in relation to the their illuminance levels respectively, as shown in Figure 6 and Figure 7.

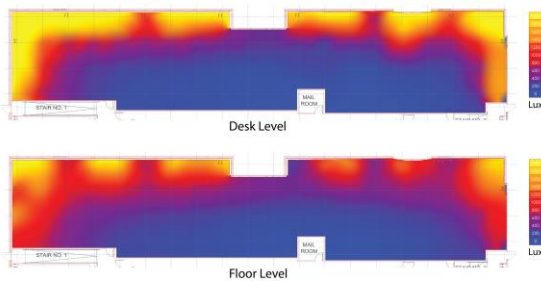

Figure 6 Visualization of measured data: Illuminance desk level and floor level, morning (10:30 am - 12:00 pm)

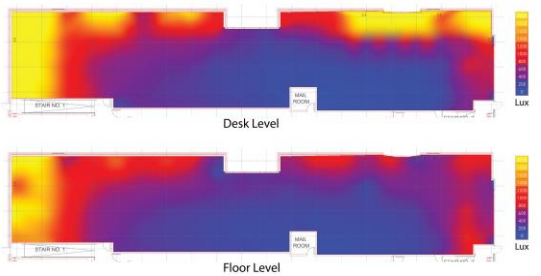

Figure 7 Visualization of measured data: Illuminance desk level and floor level, afternoon (3:30 pm - 5:00 pm)

In this paper, we focus on the integrated workflow from data acquisition to post-evaluation visualisation. Cloud plays an important role in agile data storage and synchronization, which allows fluid cross-platform integration. The graphical output from measured illuminance levels provides critical visual cues for

instant building operational improvements within the existing built environment context; for instance, lighting quality of areas with 16,000 lux or more along the perimeter (shaded yellow) can be hugely improved by implementing blinds or light redirection devices to reduce excessive glare while maintaining optimal views.

## DAYLIGHTING SIMULATION

In addition to data visualisation, we conduct another lighting simulation using Autodesk Ecotect v5. The purpose of this simulation is to compare simulated and measured performance and identify the potential gaps between them. Autodesk Ecotect v5 and Radiance simulations were used for daylight simulation. The Kalwall weather data [11] were used for Los Angeles, CA, USA. The simulation of the desk level (760 mm) and floor level were performed in the morning (10:00 am) and in the afternoon (5:00 pm). Figure 8 shows the values of daylight simulation in the morning, 10:00 am, August 22, 2012. To obtain the accuracy, we used the denser grid than the POE measured. Figure 9 shows the Radiance analysis result of the desk level in the afternoon, 5:00 pm, August 22, 2012.

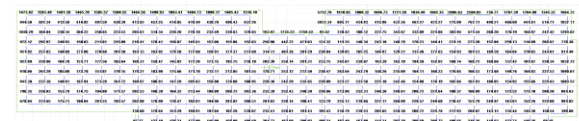

Figure 8 Values of daylight simulation (desk level, 0.76m, morning, 10:00 am)

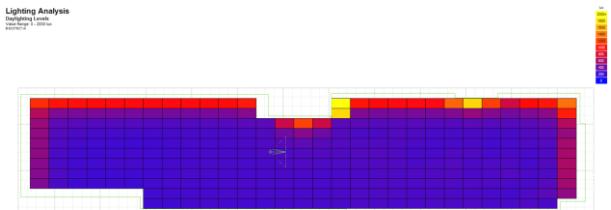

Figure 9 Daylight simulation results (desk level, 0.76m, afternoon, 5:00 pm)

## DATA ANALYSIS

In this section, we compare actual lighting performance and day lighting simulation. We conducted statistical analysis between measured and simulation data using SAS 9. Figure 10 illustrates the data distribution of daylight level at 5:00 pm on August 22, 2012. At first glance, it is apparent that there is a statistically significantly difference between measured data and simulated data ( $p < 0.05$ ). The mean illuminance level of measured data is 1,416 lux, and simulated 687 lux, which are shaded with the green solid lines in Figure 10. Table 1 shows the analyses of data comparison.

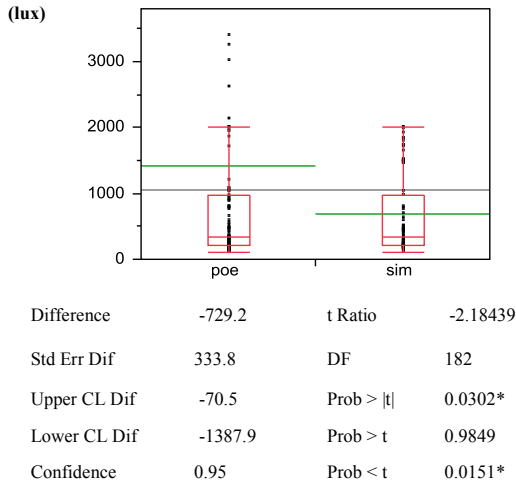

Figure 10 Comparison of measured data and simulated data, August 22, 2012, afternoon, 5:00pm.

Table 1 Means for One-way Anova

	Number	Mean	Std Error	Lower 95%	Upper 95%
poe	92	1,416	236	950	1,882
sim	92	687	236	221	1,153

Although the mean value is statistically different, we found that the quartiles (25%, 50%, 75%) are very close, as shown in Table 2. The huge gap appears at the extreme case of the Max quartile, which accounts for the divergence between POE and simulation data. Also, the value range from POE data is much wider than the simulation. The spikes occur at these areas with the direct sun exposure, in which the fluctuation of measured results is significantly high.

Table 2 Comparisons of Quartiles

Level	Min	10%	25%*	Med*	75%*	90%	Max
poe	110	150	213	345	973	2,900	18,800
sim	97	176	205	341	978	1,717	5,931

To go a step further, we conducted a pairwise analysis between measured POE data and simulation data. Figure 11 visualises the pairwise comparison at each measured spot. Overall, simulation data shows 16.33% higher than measured POE data. However, by excluding the extreme top 5% data, the difference from simulation data to measured POE data drops significantly to merely 2%, which indicates the high similarity between simulation and actual performance. The result suggests a potential reliable result using simulation as the preliminary indicator for lighting performance prediction.

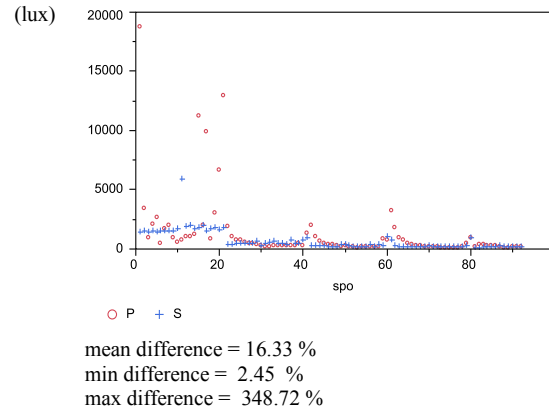

Figure 11 Matched pairwise differences between POE and simulation data

## CONCLUSION AND DISCUSSION

This study has investigated an integrated workflow from data acquisition to visualization. We demonstrate the usage through full-grid POE measurements. This approach affords an easy way of incorporating field data with associated building geometry.

Through post evaluation analyses, we identify the gap between simulation data and actual building performance. In one sense, simulation data gives a quick overview of how a building performs. Yet, with real data, we can quickly identify problematic areas and provide suggestions to improve the built environment for occupants. Also, with the visual feedback in real time, numeric data become more comprehensible for better communication.

To summarize, the preliminary study on an automated post evaluation workflow has been presented with lighting performance evaluation. The aim of this study is to provide POE researchers/investigators a more efficient way of conducting IEQ assessments, which provide insightful indicators to actual building performance. With more in-depth analyses on how and why actual performance differs from simulation will continue with the expanding to the other one - field measurements.

## ACKNOWLEDGEMENTS

The authors acknowledge Dr. Dennis R. Shelden and Michelle Lee at Gehry Technologies and Azizan Aziz at Center for Building Performance and Diagnostics, Carnegie Mellon University for valuable support, discussions, and comments.

This material is based upon work supported by the Energy Efficient Buildings (EEB) Hub, an energy innovation hub sponsored by the Department of Energy, USA under Award Number DE - EE0004261.

## REFERENCES

1. ASHRAE. (2010). Performance Measurement Protocols for Commercial Buildings: American Society of Heating, Refrigerating and Air Conditioning Engineers
2. IESNA (2011) Lighting Handbook 10th edition: Illuminating Engineering Society of North America
3. Loftness, V., Aziz, A., Choi, J., Kampschroer, K., Powell, K., Atkinson, M., & Heerwagen, J. (2009). The value of post-occupancy evaluation for building occupants and facility managers. *Intelligent Buildings International*, 1(4), 249-268. doi: 10.3763/inbi.2009.SI04
4. Loftness, V., Aziz, A., Park, J., & Cochran, E. (2011). Case Study for the David L. Lawrence Convention Center: Post Occupancy Evaluation (Buildng in Operatoin study ed.). : Green Building Alliance.
5. Meir, I. A., Garb, Y., Jiao, D., & Cicelsky, A. (2009). Post-occupancy evaluation: an inevitable step toward sustainability. *Advances in building energy research*, 3(1), 189-219.
6. Preiser, W. F. E., & Vischer, J. C. (2005). *Assessing Building Performance*. Routledge
7. The RADIANCE lighting simulation and rendering system, <http://radsite.lbl.gov/radiance/> [Last accessed on April 30, 2013]
8. Dropbox, A hosting services for cloud storage and synchronization, <http://www.dropbox.com/> [Last accessed on April 30, 2013].
9. Rhinoceros 3D, 3D modeling tools for designers, <http://www.rhino3d.com/> [Last accessed on April 30, 2013].
10. Grasshopper, A visual programming environment for design exploration in Rhinoceros 3D, <http://www.grasshopper3d.com/> [Last accessed on April 30, 2013].
11. <http://www.gsd.harvard.edu/research/gsd-square/Publications/GettingStartedwithEcotectRadianceDaysim.pdf>, kalwall Corporation, [www.kalwall.com](http://www.kalwall.com) 008].